

PLEASE CHECK WWW.MOLEX.COM FOR LATEST PART INFORMATION

Part Number: [0548190519](#)
Status: **Active**
Description: USB On-The-Go (OTG) Mini-B Receptacle, Right Angle, Through Hole Solder Tails and Shell Tabs, Lead-free

Documents:

[3D Model](#) [Product Specification PS-56579-015 \(PDF\)](#)
[Drawing \(PDF\)](#) [RoHS Certificate of Compliance \(PDF\)](#)

Agency Certification

UL E29179

General

Product Family	I/O Connectors
Series	54819
Application	Wire-to-Board
Component Type	Receptacle
MolexKits	Yes
Product Name	USB, USB OTG (On-The-Go)
Type	Mini-B

Physical

Circuits (Loaded)	5
Circuits (maximum)	5
Color - Resin	Black
Flammability	94V-0
Lock to Mating Part	Yes
Material - Metal	High Performance Alloy (HPA)
Material - Plating Mating	Gold
Material - Plating Termination	Tin
Material - Resin	High Temperature Thermoplastic
Orientation	Right Angle
PC Tail Length (in)	0.071 In
PC Tail Length (mm)	1.80 mm
PCB Retention	Yes
PCB Thickness Recommended (in)	0.040 In
PCB Thickness Recommended (mm)	1.00 mm
Packaging Type	Tray
Panel Mount	No
Pitch - Mating Interface (in)	0.031 In
Pitch - Mating Interface (mm)	0.80 mm
Plating min: Mating (µin)	30.4
Plating min: Mating (µm)	0.76
Plating min: Termination (µin)	40
Plating min: Termination (µm)	1
Polarized to Mating Part	Yes
Surface Mount Compatible (SMC)	Yes
Temperature Range - Operating	0°C to +50°C
Termination Interface: Style	Through Hole
Wire Size AWG	N/A

Electrical

Current - Maximum per Contact	1A
Shielded	Yes
Voltage - Maximum	30V

Solder Process Data

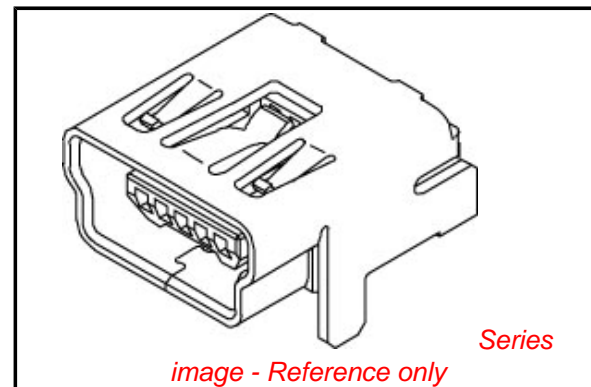

EU RoHS

**ELV and RoHS
Compliant**
REACH SVHC
 Not Reviewed
**Halogen-Free
Status**
 Not Reviewed

China RoHS



**Need more information on product
environmental compliance?**

Email productcompliance@molex.com
 For a multiple part number RoHS Certificate of Compliance, [click here](#)

Please visit the [Contact Us](#) section for any non-product compliance questions.

Search Parts in this Series

[54819Series](#)

Mates With

[59204-9401](#) , [59205-3301](#)

Duration at Max. Process Temperature (seconds)	10
Lead-free Process Capability	Reflow Capable (SMT only)
Max. Cycles at Max. Process Temperature	1
Process Temperature max. C	260

Material Info

Reference - Drawing Numbers

Packaging Specification	SPK-54819-001
Product Specification	PS-56579-015, RPS-54819-030, RPS-54819-032, RPS-54819-033, RPS-56579-003, RPS-56579-004, RPS-56579-007, RPS-56579-008, RPS-56579-009, RPS-56579-010
Sales Drawing	SD-54819-026

This document was generated on 06/07/2010

PLEASE CHECK WWW.MOLEX.COM FOR LATEST PART INFORMATION

コネクタ実装側 (CONNECTOR MOUNT SIDE)

逆側 (REVERSE SIDE)

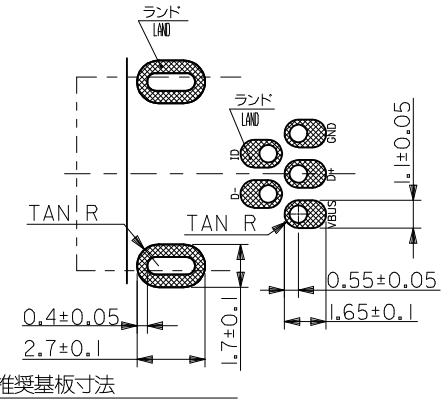
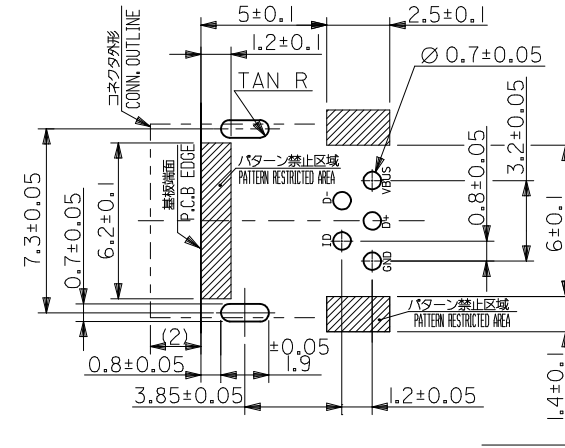
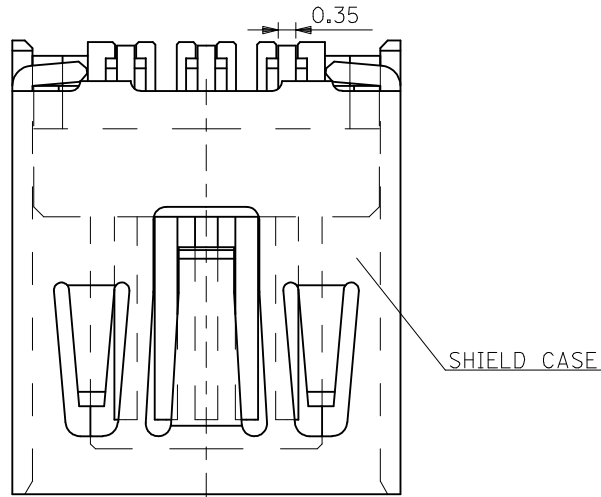

推奨基板寸法
RECOMMENDED P.C.B. PATTERN LAYOUT

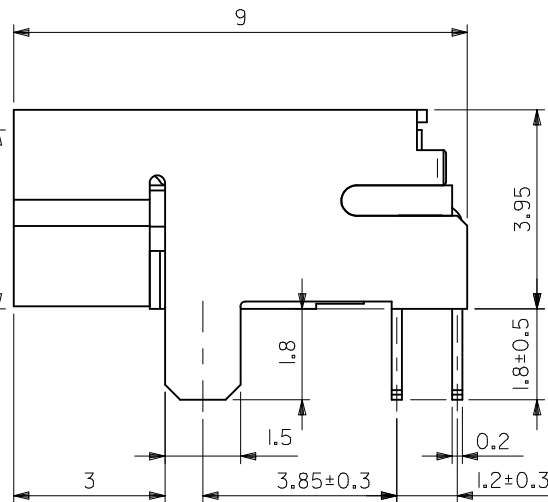
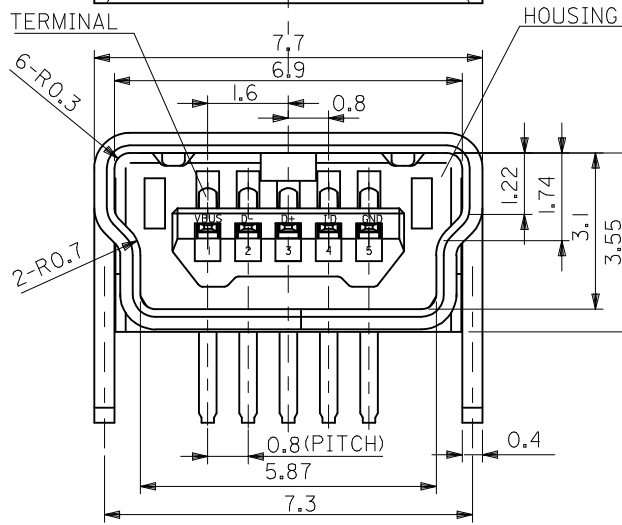

- 注記 1. 材質
NOTES MATERIAL
ハウジング: PA, ガラス充填, 黒色, UL94V-0
HOUSING: PA, GLASS FILLED, BLACK, UL94V-0
ターミナル: 銅合金 (t=0.2)
TERMINAL: COPPER ALLOY (t=0.2)
シールド ケース: 銅合金 (t=0.4)
SHIELD CASE: COPPER ALLOY (t=0.4)
2. メッキ仕様
PLATING
ターミナル
TERMINAL
接点部: 金メッキ 0.76MICRO METER MIN.
CONTACT AREA: GOLD 0.76MICRO METER MIN.
半田付カ部: 錫メッキ 1.0MICRO METER MIN.
SOLDER TAIL AREA: TIN 1.0MICRO METER MIN.
下地部: ニッケルメッキ 1.0MICRO METER MIN.
UNDER PLATING: NICKEL 1.0MICRO METER MIN.
シールド ケース
SHIELD CASE
: 錫メッキ 1.0 MICROMETER MIN.
: TIN 1.0MICRO METER MIN.
下地部: ニッケルメッキ 1.0MICRO METER MIN.
UNDER PLATING: NICKEL 1.0MICRO METER MIN.
3. 本製品は54819-0511の鉛フリー品である。
THIS PRODUCT IS LEAD FREE OF 54819-0511.

54819-0519
MATERIAL No.

MODEL No.54819-**-19

REVISED EC NO: J2009-1533 DRW:ESATO 2009/06/25 CHKD:HMATSUMOTO 2009/06/25 APPR:NIKIITA 2009/06/25	GENERAL TOLERANCES (UNLESS SPECIFIED)		DIMENSION STYLE MM ONLY	SCALE 10:1	DESIGN UNITS METRIC	THIRD ANGLE PROJECTION
	10 UNDER	±0.2	DRAWN BY M. NAGATA	DATE 2004/04/28	TITLE USB SERIES MINI-B RECEPTACLE ASS'Y -LEAD FREE-	
	10 OVER 30 UNDER	±0.25	CHECKED BY K. TOJO	DATE 2004/04/28	MOLEX INCORPORATED	
	30 OVER	±0.3	APPROVED BY M. SASAO	DATE 2004/04/28	DOCUMENT NO. SD-54819-026	SHEET NO. 1 OF 2
REV A	DESCRIPTION	ANGULAR ±3 ° DRAFT WHERE APPLICABLE MUST REMAIN WITHIN DIMENSIONS	SIZE A3	THIS DRAWING CONTAINS INFORMATION THAT IS PROPRIETARY TO MOLEX INCORPORATED AND SHOULD NOT BE USED WITHOUT WRITTEN PERMISSION		

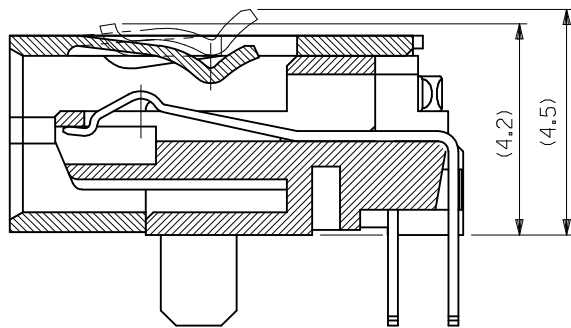

SECTION

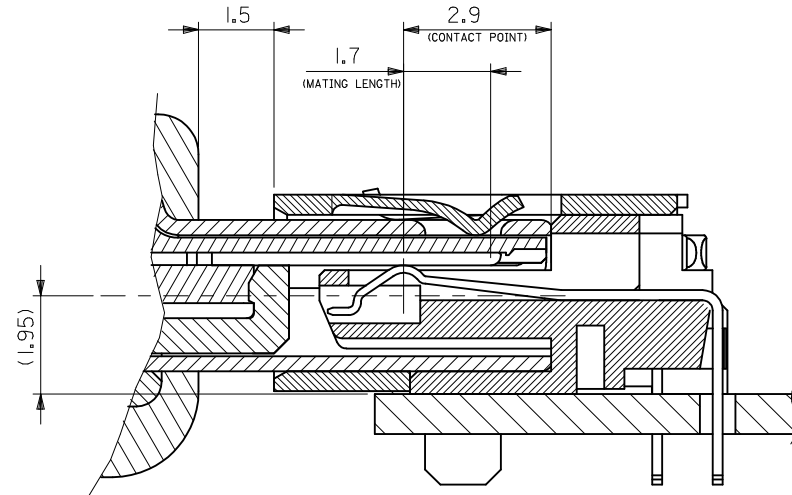

MATING

MODEL NO. 54819-***19

REVISED EC NO: J2009-1533 DRW: NESATO 2009/06/25 CHK'D: MATSUMOTO 2009/06/25 APPR: NUKITA 2009/06/25	GENERAL TOLERANCES (UNLESS SPECIFIED)		DIMENSION STYLE MM ONLY		SCALE 10:1	DESIGN UNITS METRIC	THIRD ANGLE PROJECTION	
	10 UNDER	±0.2	DRAWN BY M. NAGATA	DATE 2004/04/28	TITLE USB SERIES MINI-B RECEPTACLE ASS'Y -LEAD FREE-			
	10 OVER 30 UNDER	±0.25	CHECKED BY K. TOJO	DATE 2004/04/28				
	30 OVER	±0.3	APPROVED BY M. SASAO	DATE 2004/04/28	MOLEX INCORPORATED DOCUMENT NO. SD-54819-026 SHEET NO. 2 OF 2			
ANGULAR ±3 °		MATERIAL NO. SEE SHEET 1						
DRAFT WHERE APPLICABLE MUST REMAIN WITHIN DIMENSIONS		THIS DRAWING CONTAINS INFORMATION THAT IS PROPRIETARY TO MOLEX INCORPORATED AND SHOULD NOT BE USED WITHOUT WRITTEN PERMISSION						