



ELECTRONICS

Preliminary

TO :
DATE : Dec. 22. 2005

SAMSUNG TFT-LCD
MODEL NO.:LTE430WQ-F05

NOTE :

Any Modification of Spec is not allowed without SEC's permission.

APPROVED BY :

PREPARED BY :

SAMSUNG ELECTRONICS CO., LTD.



Doc.No.	LTE430WQ-F05	Rev.No	05-000-E-051222	Page	1 /28
---------	--------------	--------	-----------------	------	-------

CONTENTS

Revision History	----- (3)
General Description	----- (4)
1. Absolute Maximum Ratings	----- (5)
1.1 Absolute Ratings Of Environment	
1.2 Electrical Absolute Ratings	
2. Optical Characteristics	----- (7)
3. Electrical Characteristics	----- (10)
3.1 TFT LCD Module	
3.2 Back-Light Unit	
4. Block Diagram	----- (12)
4.1 TFT LCD Module	
4.2 Back-Light Unit	
5. Input Terminal Pin Assignment	----- (13)
5.1 Input Signal & Power	
5.2 Back-Light Unit	
5.3 Input Signals, Basic Display Colors and Gray Scale of Each Color.	
5.4 Pixel Format	
6. Interface Timing	----- (17)
6.1 Timing Parameters	
6.2 Power ON/OFF Sequence	
7. Outline Dimension	----- (23)
8. Packing	----- (25)
9. Markings & others	----- (26)
10. General Precautions	----- (27)
10.1 Handling	
10.2 Storage	
10.3 Operation	
10.4 Others	

Revision History

Preliminary

Date	Rev.No.	Page	Summary
Dec.22.2005	000		Rev.000 was first issues.

Mechanical Information

ITEM		MIN.	TYP.	MAX.	NOTE
Module size	Horizontal (H)	105.2	105.5	105.7	
	Vertical (V)	67.0	67.2	67.4	
	Depth (D)	-	TBD	TBD	
Weight		-	TBD	TBD	

1. Absolute Maximum Ratings

1.1 Absolute Ratings Of Environment

ITEM	SYMBOL	MIN.	MAX.	UNIT	NOTE
Storage temperature	T_{STG}	-30	70	°C	(1)
Operating temperature (Temperature of glass surface)	T_{OPR}	-20	60	°C	(1)

Note (1) Temperature and relative humidity range are shown in the figure below.
 90 % RH Max. ($50\text{ }^{\circ}\text{C} \geq T_a$)
 Maximum wet - bulb temperature at $39\text{ }^{\circ}\text{C}$ or less. ($T_a > 50\text{ }^{\circ}\text{C}$) No condensation.

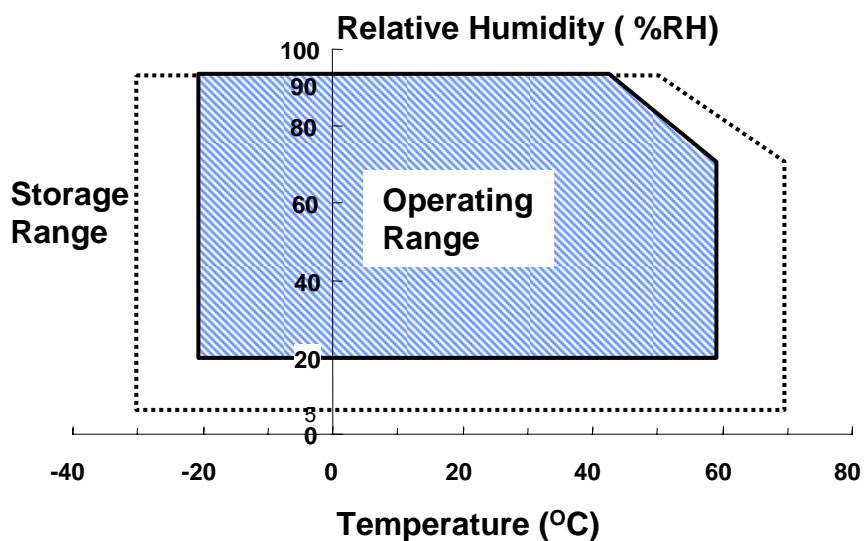

General Description

Description

LTE430WQ-F0x is a color active matrix TFT (Thin Film Transistor) liquid crystal display (LCD) that uses amorphous silicon TFT as a switching devices. This model is composed of a TFT LCD panel, a driver circuit and a back-light system. The resolution of a 4.3" Contains 480 x 272 pixels and can display up to 16,777,216 colors.

Features

- High Brightness
- High contrast ratio
- 8Bits color depth
- WQVGA (480 x 272 pixels) resolution
- DE(Data enable) mode

Application

- PMP / p-CNS machine application product
- Display terminals for AV application products

General Information

ITEM	SPECIFICATION	UNIT	NOTE
Display area	95.04(H) x 53.856(V) (4.3" diagonal)	mm	
Driver element	a-Si TFT active matrix		
Display colors	16,777,212		
Number of pixel	480×RGB(H) x 272(V)	pixel	
Pixel arrangement	RGB stripe		
Pixel pitch	0.198(H) x 0.198(V) (TYP.)	mm	128ppi
Display Mode	Normally black		
Surface treatment	Clear type		

1.2 Electrical Absolute Ratings

(1) TFT LCD Module

(V_{SS} = GND = 0 V)

ITEM	SYMBOL	MIN.	MAX.	UNIT	NOTE
Logic Input Voltage	VDD	-0.5	3.0	V	(1)
Analog Input Voltage	AVDD5	-0.5	6.0	V	(1)

NOTE (1) Within Ta = 25 ± 2 °C

(2) Back-Light Unit

Ta = 25 ± 2 °C

ITEM	SYMBOL	MIN.	MAX.	UNIT	NOTE
LED current	IB	-	50	mA	(1)

NOTE (1) Permanent damage to the device may occur if maximum values are exceeded or reverse voltage loaded.
Functional operation should be restricted to the conditions described under Normal Operating Conditions.

2. Optical Characteristics

The following items are measured under stable conditions. The optical characteristics should be measured in a dark room or equivalent state with the methods shown in Note (5).

Measuring equipment : TOPCON BM-5A,EZ-CONTRAST

* Ta = 25 ± 2°C , VDD=2.5V, fv= 60Hz, fDCLK=9.0MHz, IL = 18mA

ITEM	SYMBOL	CONDITION	MIN.	TYP.	MAX.	UNIT	NOTE	
Contrast Ratio (1 Points)	CR	$\phi = 0,$ $\theta = 0$ Normal Viewing Angle	100	400			(1), (2), (5)	
Response Time at Ta	Rising		TR	-	10	45	msec	(1), (3)
	Falling		TF	-	15	45		
Luminance of White (center)	YL			280	350	-	cd/m ²	(1), (4)
Color Chromaticity (CIE)	Red		Rx	0.561	0.611	0.661		(1), (5)
			Ry	0.305	0.355	0.405		
	Green		Gx	0.296	0.346	0.396		
			Gy	0.503	0.553	0.603		
	Blue		Bx	0.096	0.146	0.196		
			By	0.078	0.128	0.178		
	White	Wx	0.261	0.311	0.361			
		Wy	0.284	0.334	0.384			
Viewing Angle	Hor.	θ_L	70	80	-	Degrees	(1)	
		θ_R	70	80	-			
	Ver.	ϕ_H	70	80	-			
		ϕ_L	70	80	-			
5 Points White Variation	δ_L		-	-	1.45		(6) Ez-contrast	

Note 1) Definition of Viewing Angle : Viewing angle range($10 \leq C/R$)

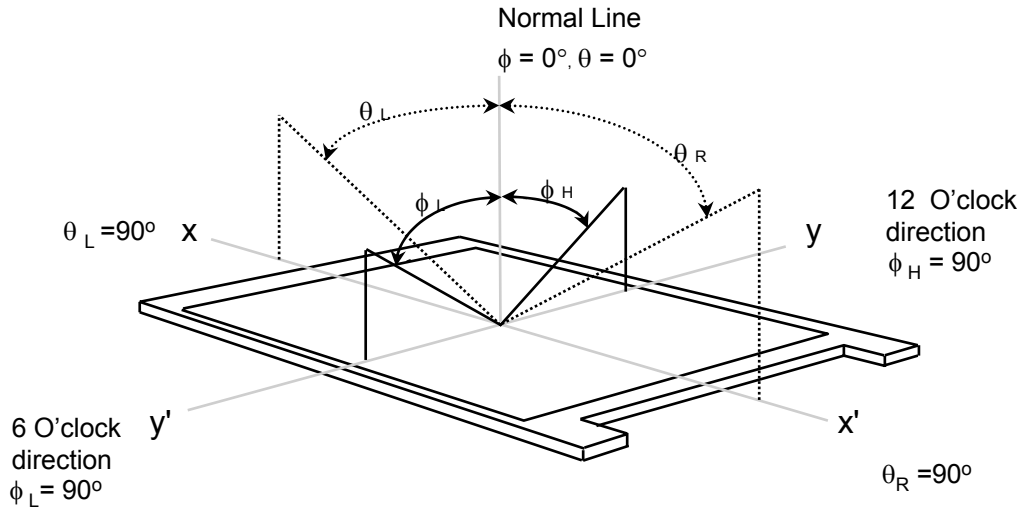

Note 2) Definition of Contrast Ratio (CR) : Ratio of gray max (Gmax) ,gray min (Gmin) at center point

$$CR = \frac{\text{gray max (Gmax)}}{\text{gray min (Gmin)}}$$

Note 3) Definition of Response time :

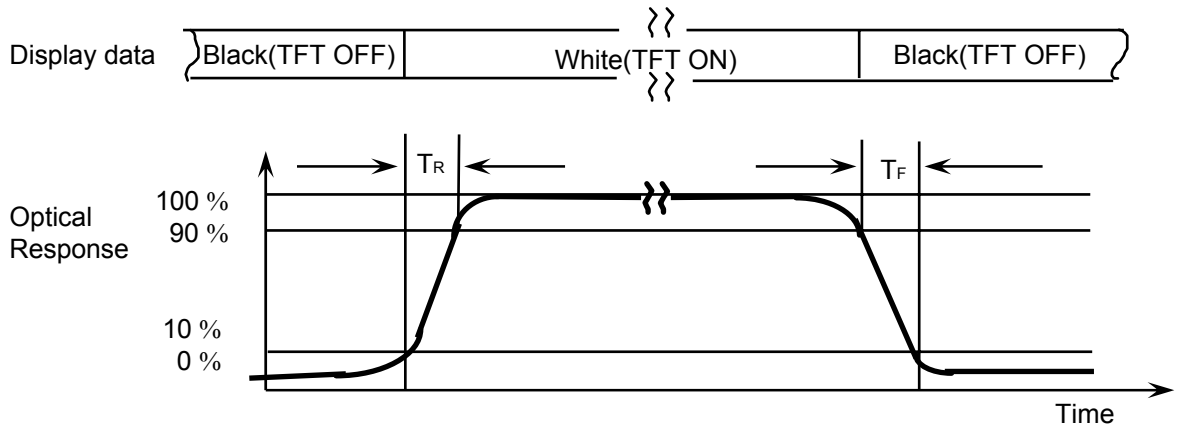

Note 4) Definition of Luminance of White : measure the luminance of white at center point(@ ③)

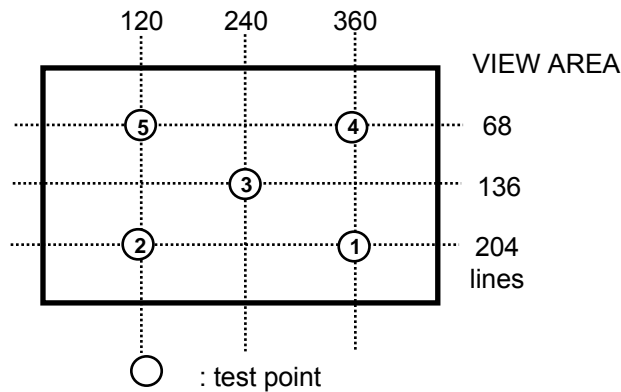

Note 5) After stabilizing and leaving the panel alone at a given temperature for 10 minutes, the measurement should be executed. Measurement should be executed in a stable, windless, and dark room.
 This should be measured in the center of screen.
 LED current : 36 mA
 Environment condition : $T_a = 25 \pm 2 \text{ }^\circ\text{C}$

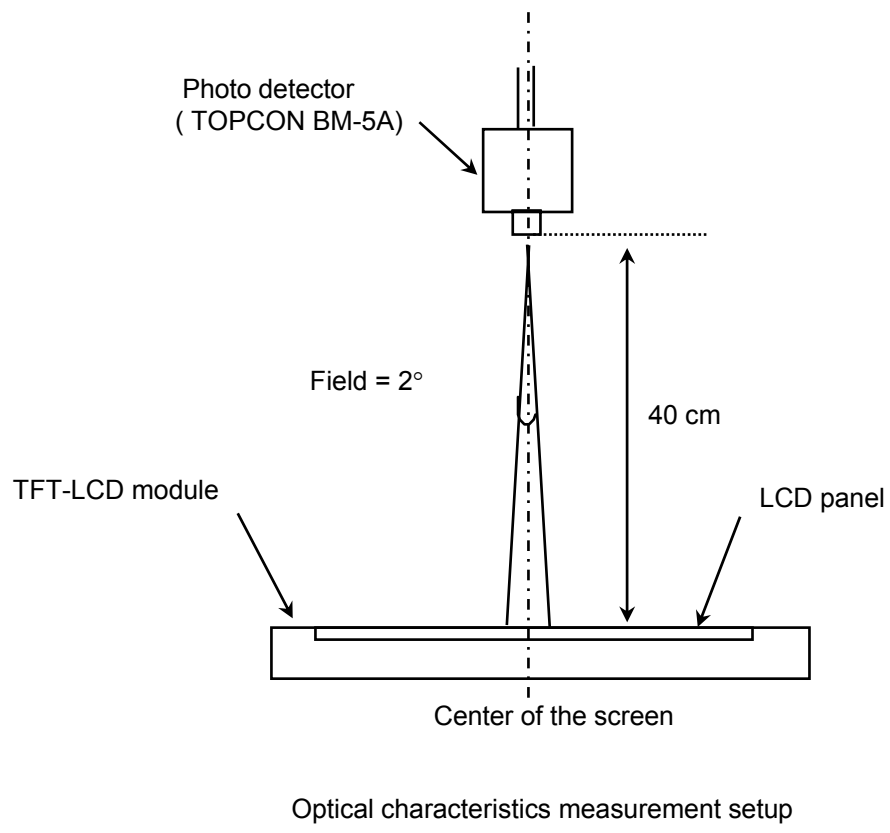

Note 6) Definition of 5 points white variation (δ_L) [① ~ ⑤]

$$\delta_L = \frac{\text{Maximum luminance of 5 points}}{\text{Minimum luminance of 5 points}}$$

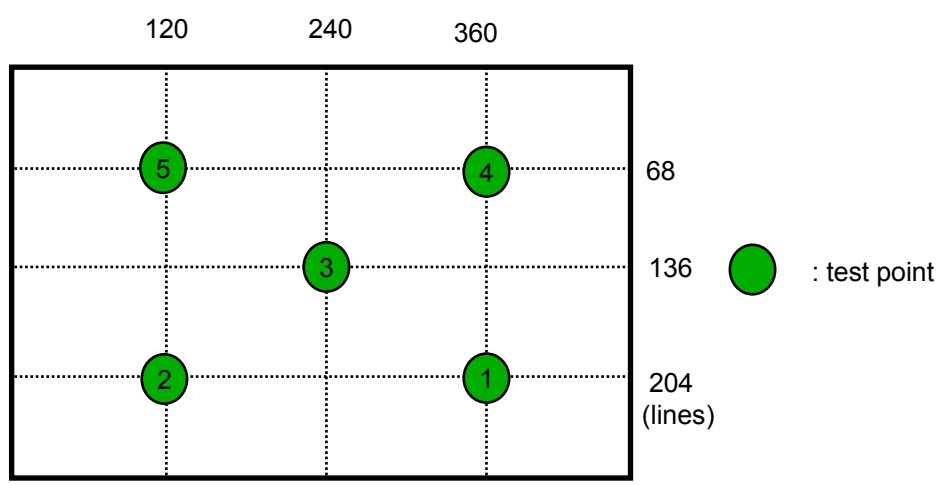

4. BLOCK DIAGRAM

4.1 TFT LCD MODULE

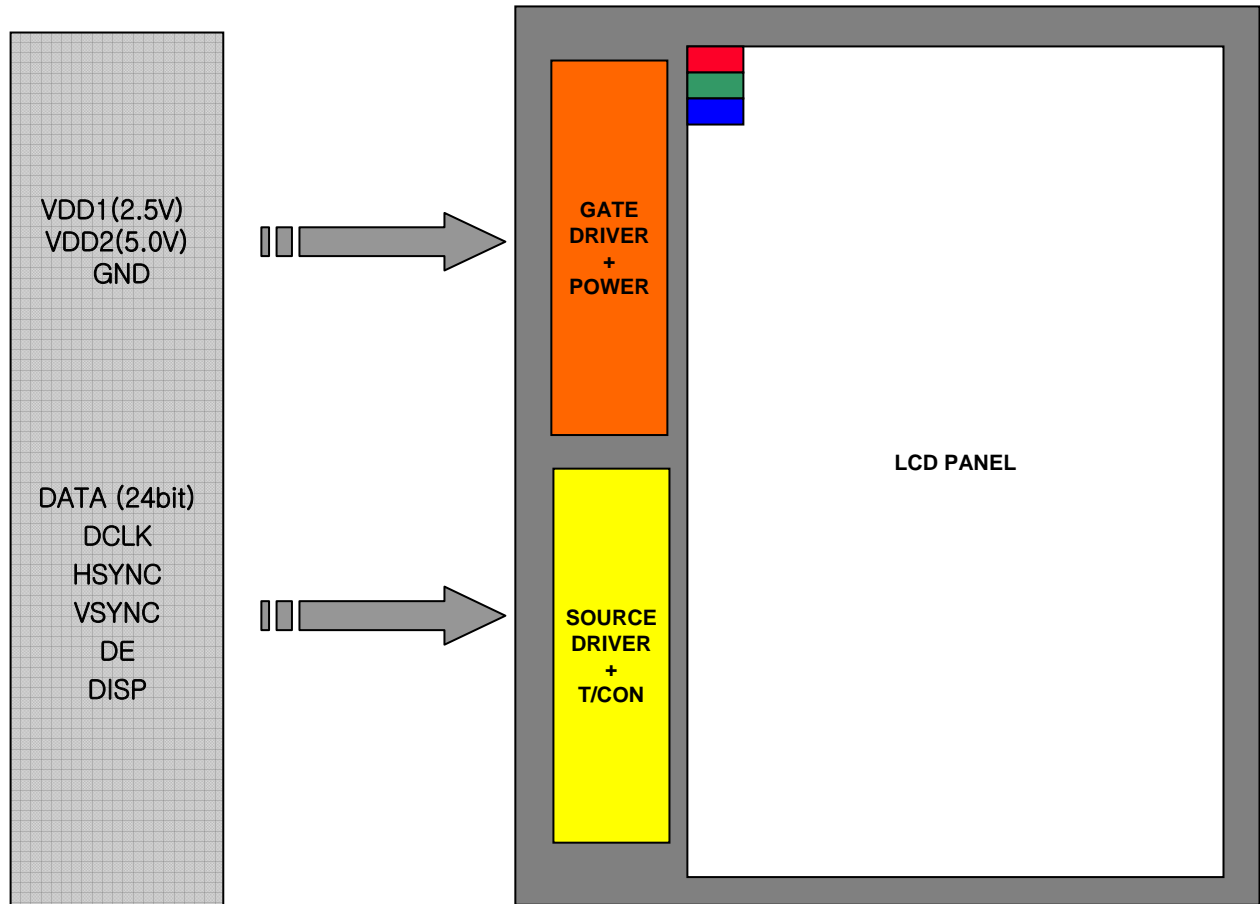

4.2 BACKLIGHT UNIT

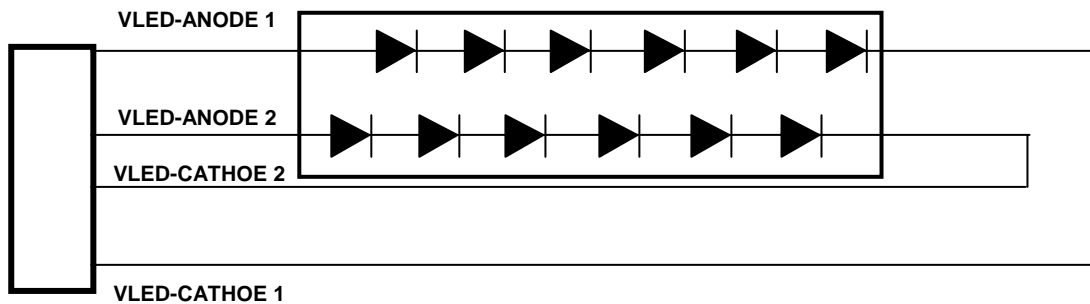

3. Electrical Characteristics

Preliminary

3.1 TFT LCD Module

Ta = 25 ± 2°C

ITEM	SYMBOL	MIN	TYP	MAX	UNIT	NOTE
Logic Supply Voltage	VDD	2.3	2.5	2.7	V	
Analog Supply Voltage	AVDD5	4.8	5.0	5.2	V	
Vsync Frequency	fV		59.94		Hz	
Hsync Frequency	fH		17.14		Hz	
Main Frequency	fDCLK		9.0	15.0	MHz	
Current Consumption	Logic current	IDD		TBD	mA	(1),(3)
	Analog current	IAVDD		TBD	mA	(1),(3)
Power Consumption	256Gray	PWR		TBD	mW	(1),(3)

Note (1) fV=60Hz, fDCLK = 9.0MHZ, VDD = 2.5V , AVDD5 = 5.0V, DC Current.

(2) 1 pixel /clock

(3) Power dissipation check pattern : 256Gray(vertical)

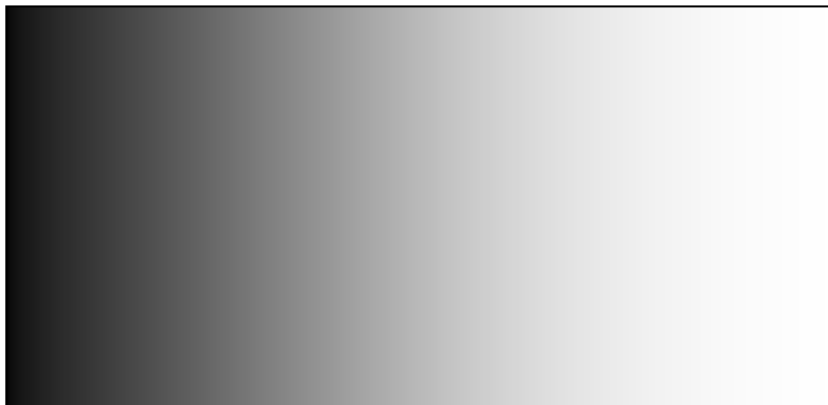

3.2 Back-Light Unit

The back-light system is an edge - lighting type with six white LED(Light Emitting Diode)s.

Ta=25 ± 2°C

ITEM	SYMB	MIN	TYP	MAX	UNIT	NOTE
LED's Current	IB	-	36	-	mA	(1)
Power Consumption	PBL	-	(710)	-	mW	(2)

Note

- (1) 6 LEDs series X 2 parallel
- (2) Where $IB = 36mA$, $VB = PBL / (IB)$

5. Input Terminal Pin Assignment

5.1. Input Signal & Power (Connector : 40 PIN FPC)

Pin NO	Symbol	Description	Remark	Pin NO	Symbol	Description	Remark
1	VSS	Ground		21	B0	Blue data(LSB)	
2	VSS	Ground		22	B1	Blue data	
3	VDD	POWER SUPPLY(+2.5V)		23	B2	Blue data	
4	VDD	POWER SUPPLY(+2.5V)		24	B3	Blue data	
5	R0	Red data(LSB)		25	B4	Blue data	
6	R1	Red data		26	B5	Blue data	
7	R2	Red data		27	B6	Blue data	
8	R3	Red data		28	B7	Blue data(MSB)	
9	R4	Red data		29	VSS	Ground	
10	R5	Red data		30	PCLK	Pixel clock	
11	R6	Red data		31	DISP	Display on/off	
12	R7	Red data(MSB)		32	HSYNC	Horizontal Sync Signal	
13	G0	Green data(LSB)		33	VSYNC	Vertical Sync Signal	
14	G1	Green data		34	DE	Data Enable	
15	G2	Green data		35	AVDD5	Power supply(+5V)	
16	G3	Green data		36	AVDD5	Power supply(+5V)	
17	G4	Green data		37	NC	No connection	
18	G5	Green data		38	NC	No connection	
19	G6	Green data		39	VSS	Ground	
20	G7	Green data(MSB)		40	VSS	Ground	

5.2 Back- Light Unit(Connector : 4 PIN FPC)

Pin No.	Symbol	Function
1	VLED 1 -	Ground(cathode)
2	VLED 2-	Ground(cathode)
3	VLED 2+	LED Input terminal(anode)
4	VLED 1+	LED Input terminal(anode)

5.3 Input Signal, Basic Display Colors and Gray Scale of Each Colors

Color	Display	Data Signal																					Gray Scale Level			
		Red							Green							Blue										
		R0	R1	R2	R3	R4	R5	R6	R7	G0	G1	G2	G3	G4	G5	G6	G7	B0	B1	B2	B3	B4		B5	B6	B7
Basic Color	Black	0	0	0	0	0	0	0	0	0	0	0	0	0	0	0	0	0	0	0	0	0	0	0	-	
	Blue	0	0	0	0	0	0	0	0	0	0	0	0	0	0	0	0	1	1	1	1	1	1	1	1	-
	Green	0	0	0	0	0	0	0	0	1	1	1	1	1	1	1	1	0	0	0	0	0	0	0	0	-
	Cyan	0	0	0	0	0	0	0	0	1	1	1	1	1	1	1	1	1	1	1	1	1	1	1	1	-
	Red	1	1	1	1	1	1	1	1	0	0	0	0	0	0	0	0	0	0	0	0	0	0	0	0	-
	Magenta	1	1	1	1	1	1	1	1	0	0	0	0	0	0	0	0	1	1	1	1	1	1	1	1	-
	Yellow	1	1	1	1	1	1	1	1	1	1	1	1	1	1	1	1	0	0	0	0	0	0	0	0	-
	White	1	1	1	1	1	1	1	1	1	1	1	1	1	1	1	1	1	1	1	1	1	1	1	1	-
Gray Scale of Red	Black	0	0	0	0	0	0	0	0	0	0	0	0	0	0	0	0	0	0	0	0	0	0	0	R0	
	Dark ↑	1	0	0	0	0	0	0	0	0	0	0	0	0	0	0	0	0	0	0	0	0	0	0	R1	
		0	1	0	0	0	0	0	0	0	0	0	0	0	0	0	0	0	0	0	0	0	0	0	R2	
		:	:	:	:	:	:	:	:	:	:	:	:	:	:	:	:	:	:	:	:	:	:	:	:	:
		:	:	:	:	:	:	:	:	:	:	:	:	:	:	:	:	:	:	:	:	:	:	:	:	:
	Light ↓	1	0	1	1	1	1	1	1	0	0	0	0	0	0	0	0	0	0	0	0	0	0	0	R253	
		0	1	1	1	1	1	1	1	0	0	0	0	0	0	0	0	0	0	0	0	0	0	0	R254	
	Red	1	1	1	1	1	1	1	1	0	0	0	0	0	0	0	0	0	0	0	0	0	0	0	R255	
Gray Scale of Green	Black	0	0	0	0	0	0	0	0	0	0	0	0	0	0	0	0	0	0	0	0	0	0	0	G0	
	Dark ↑	0	0	0	0	0	0	0	0	1	0	0	0	0	0	0	0	0	0	0	0	0	0	0	G1	
		0	0	0	0	0	0	0	0	0	1	0	0	0	0	0	0	0	0	0	0	0	0	0	G2	
		:	:	:	:	:	:	:	:	:	:	:	:	:	:	:	:	:	:	:	:	:	:	:	:	:
		:	:	:	:	:	:	:	:	:	:	:	:	:	:	:	:	:	:	:	:	:	:	:	:	:
	Light ↓	0	0	0	0	0	0	0	0	1	0	1	1	1	1	1	1	0	0	0	0	0	0	0	G253	
		0	0	0	0	0	0	0	0	0	1	1	1	1	1	1	1	0	0	0	0	0	0	0	G254	
	Green	0	0	0	0	0	0	0	0	1	1	1	1	1	1	1	1	0	0	0	0	0	0	0	G255	
Gray Scale of Blue	Black	0	0	0	0	0	0	0	0	0	0	0	0	0	0	0	0	0	0	0	0	0	0	0	B0	
	Dark ↑	0	0	0	0	0	0	0	0	0	0	0	0	0	0	0	0	1	0	0	0	0	0	0	B1	
		0	0	0	0	0	0	0	0	0	0	0	0	0	0	0	0	0	1	0	0	0	0	0	B2	
		:	:	:	:	:	:	:	:	:	:	:	:	:	:	:	:	:	:	:	:	:	:	:	:	:
		:	:	:	:	:	:	:	:	:	:	:	:	:	:	:	:	:	:	:	:	:	:	:	:	:
	Light ↓	0	0	0	0	0	0	0	0	0	0	0	0	0	0	0	0	1	0	1	1	1	1	1	B253	
		0	0	0	0	0	0	0	0	0	0	0	0	0	0	0	0	0	1	1	1	1	1	1	B254	
	Blue	0	0	0	0	0	0	0	0	0	0	0	0	0	0	0	0	1	1	1	1	1	1	1	B255	

Note

(1) Definition of Gray : Rn : Red Gray, Gn : Green Gray, Bn : Blue Gray (n = Gray level)

(2) Input Signal : 0 = Low level voltage, 1 = High level voltage

5.4 Pixel Format

Preliminary

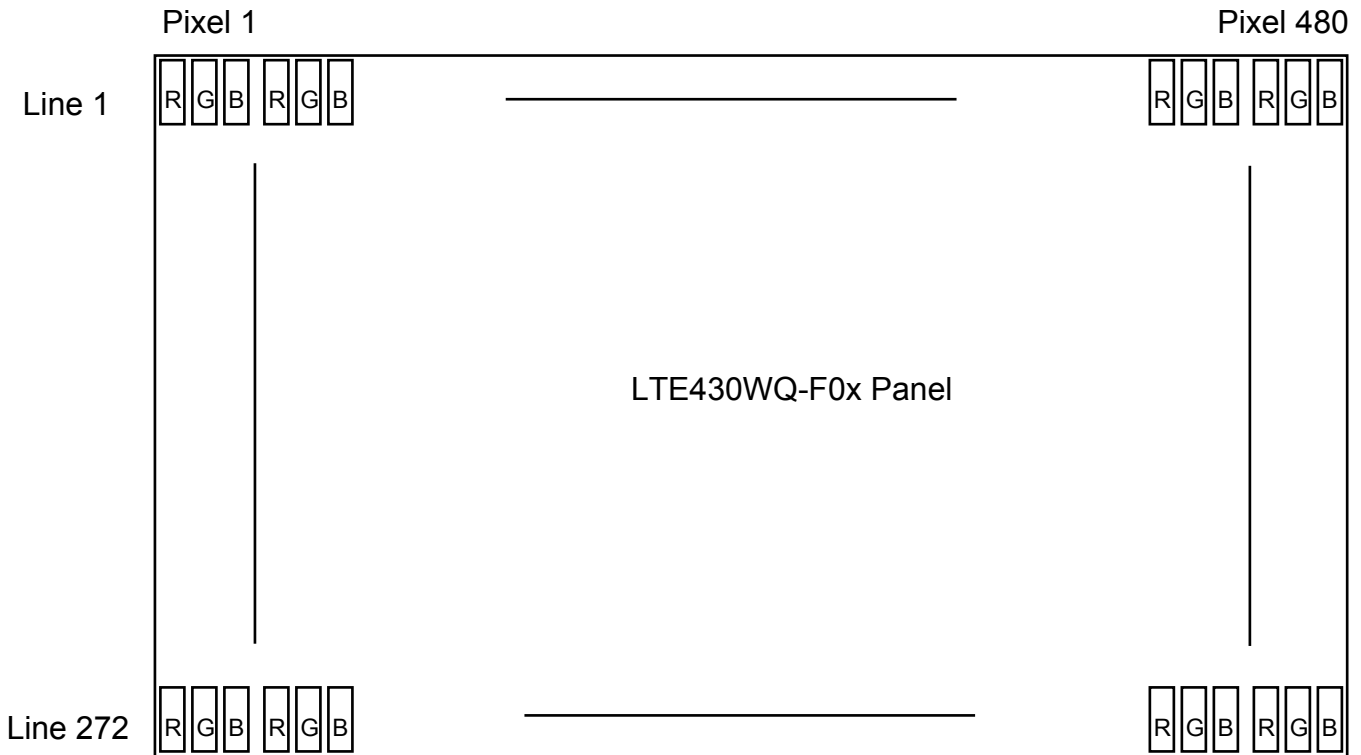

6. Interface Timing

6.1 Timing Parameters

Timing Requirement1($T_A = 25^\circ\text{C}$, $V_{DD1} = 2.3\text{V to } 2.7\text{V}$, $V_{SS1} = 0\text{V}$)

Parameter	Symbol	MIN	TYP	MAX	Unit	Remark
Clock cycle	1/tc		9.00	15	MHz	
Hsync cycle	1/fH		17.14		KHz	
Vsync cycle	1/fV		59.94		Hz	
Horizontal signal						
Horizontal cycle	th		525* ¹		CLK	
Horizontal display period	thd	480			CLK	
Horizontal Front porch	thf	2			CLK	*2
Horizontal Pulse width	thp	2	41		CLK	*2
Horizontal Back porch	thb	2			CLK	*2
Vertical signal						
Vertical cycle	tv		286		H	
Vertical display period	tvd	272			H	
Vertical Front porch	tvf	2	2		H	
Vertical Pulse width	tvp	2	10		H	
Vertical Back porch	tvb	2	2		H	

*1. thd=480CLK, thf=2CLK, thp=41CLK, thb=2CLK

$$525\text{CLK} = 480\text{CLK} + 2\text{CLK} + 41\text{CLK} + 2\text{CLK}$$

*2. thf+thp+thb > 44

6.2 Timing Chart

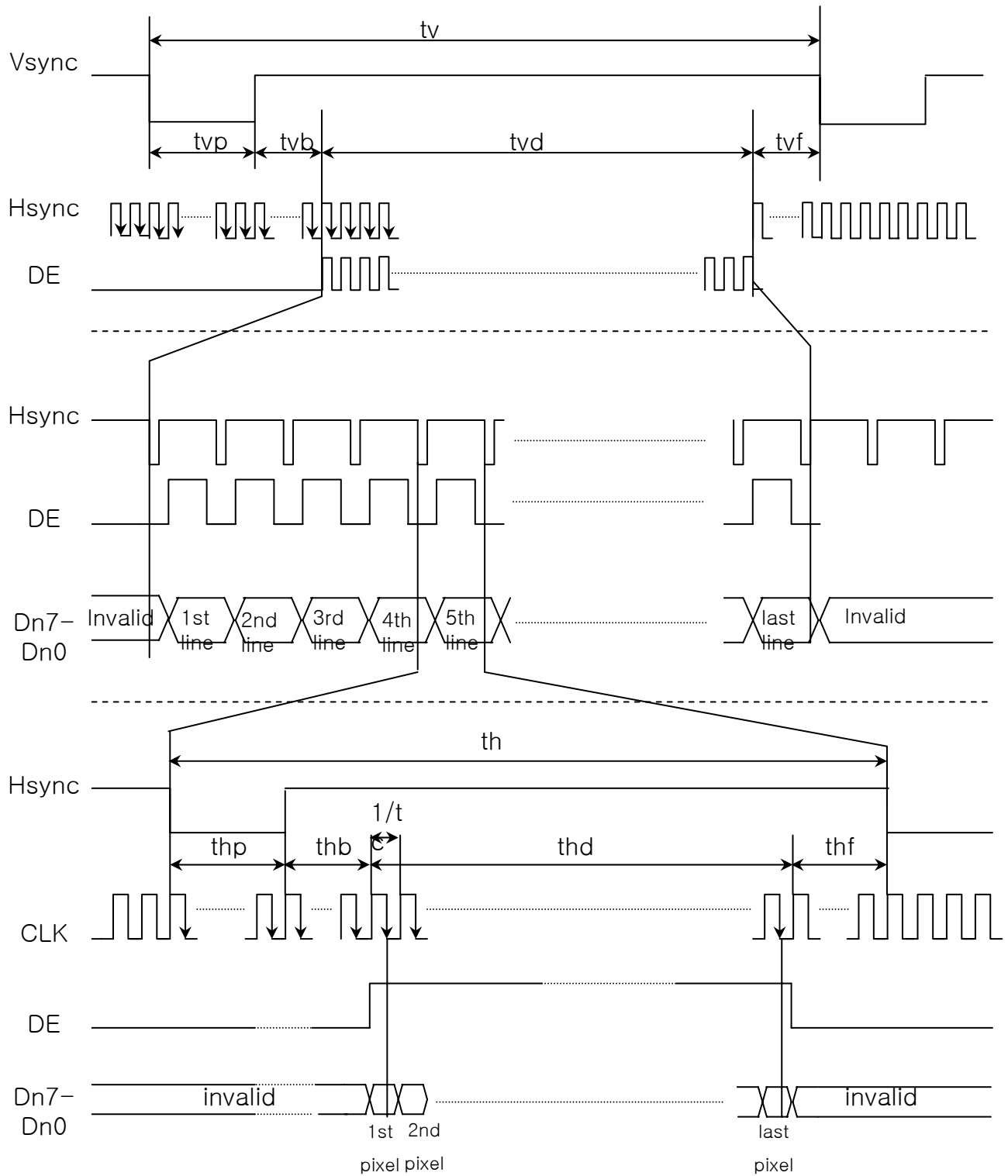

6.3 Timing Requirement2 ($T_A = 25^\circ\text{C}$, $V_{DD1} = 2.3\text{V}$ to 2.7V , $V_{SS1} = 0\text{V}$, $t_r = t_f = 2.0\text{ns}$)

Parameter	Symbol	Condition	MIN	TYP	MAX	Unit
DISP Setup Time	tdiss	DISP	10	-	-	ns
DISP Hold Time	tdish		10	-	-	ns
Clock Period	PW CLK	CLK	66.7	-	-	ns
Clock Pulse High Period	PWH		26.7	-	-	ns
Clock Pulse Low Period	PWL		26.7	-	-	ns
Hsync Setup Time	ths	Hsync	10	-	-	ns
Hsync Hold Time	thh		10	-	-	ns
Data Setup Time	tds	D00-D27	10	-	-	ns
Data Hold Time	tdh		10	-	-	ns
DE Setup Time	tdes	DE	10	-	-	ns
DE Hold Time	tdeh		10	-	-	ns
Vsync Setup Time	tvhs	Vsync	10	-	-	ns
Vsync Hold Time	tvhh		10	-	-	ns

t_r, t_f is defined 10%~90% of signal amplitude

6.4 Timing Chart

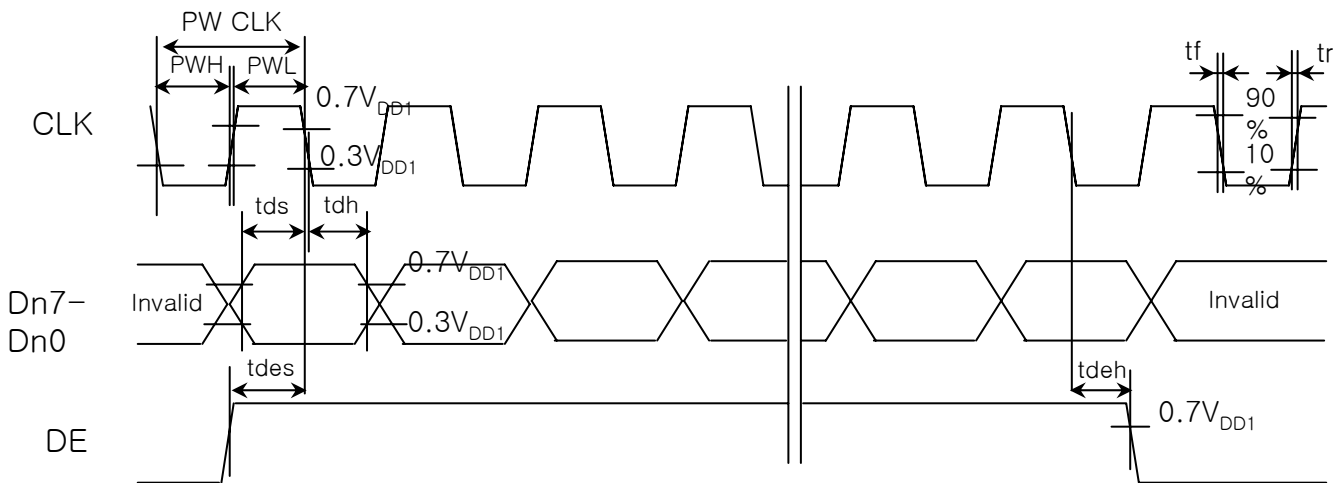
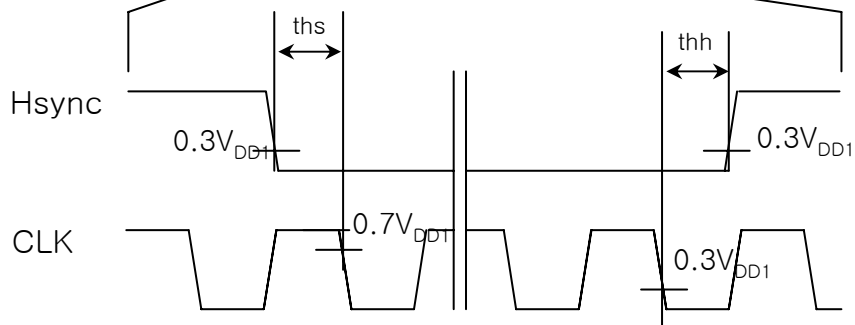
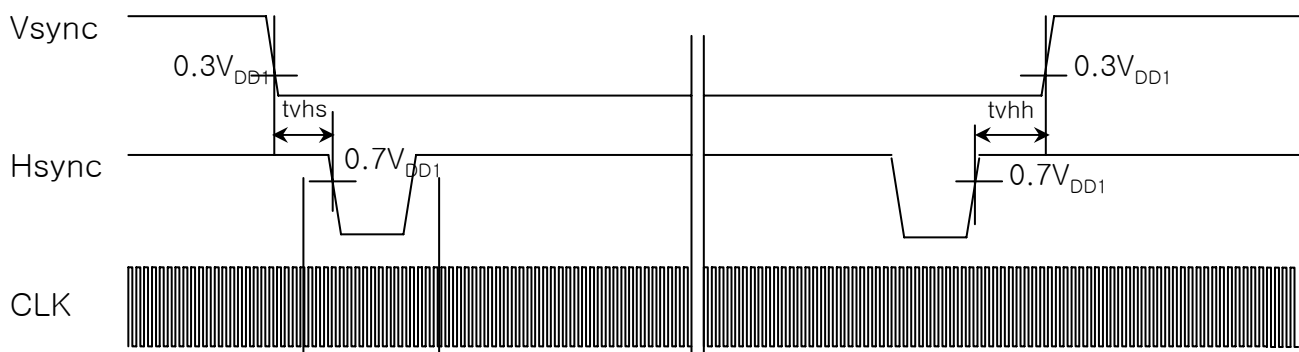
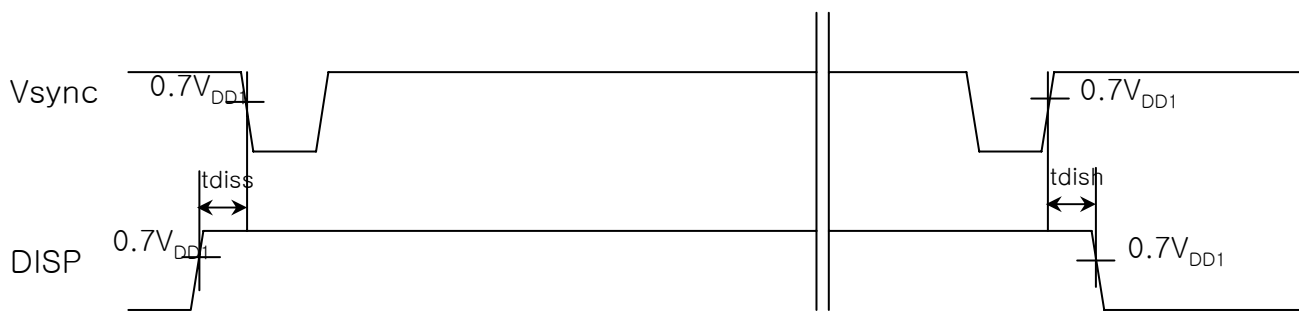

6.5 Power ON/OFF Sequence

: To prevent a latch-up or DC operation of the LCD module, the power on/off sequence should be as the diagram below.

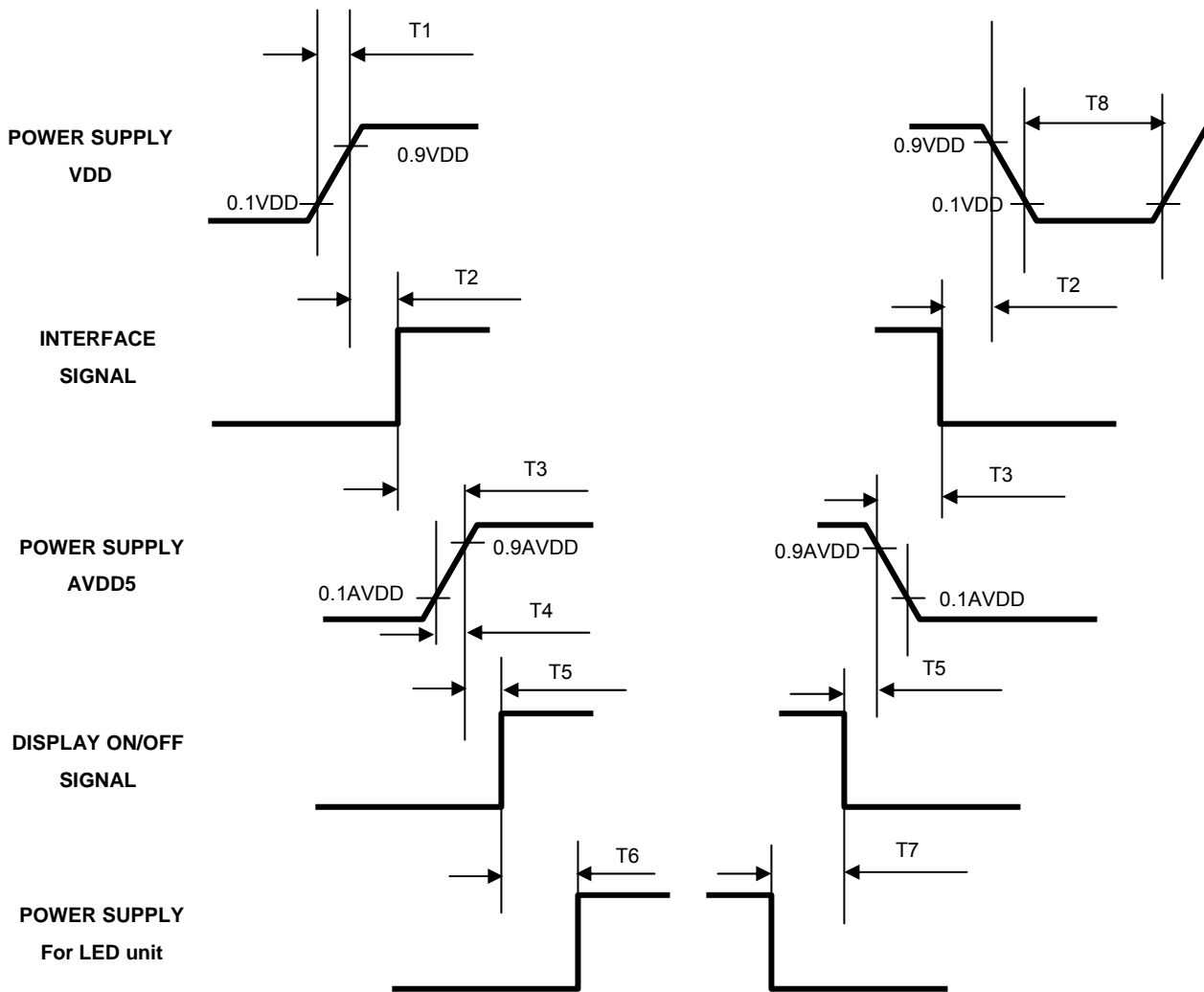

Power ON/OFF Sequence

Symbol	Specification	Symbol	Specification
T1	$0 \leq T1 \leq 10 \text{ msec}$	T5	$0 \leq T5 \leq 160 \text{ msec}$
T2	$0 \leq T2 \leq 100 \text{ msec}$	T6	$160 \text{ msec} \leq T6$
T3	$0 \leq T3 \leq 50 \text{ msec}$	T7	$160 \text{ msec} \leq T7$
T4	$0 \leq T4 \leq 10 \text{ msec}$	T8	$1 \text{ sec} \leq T8$

NOTE.

- (1) The supply voltage of the external system for the module input should be the same as the definition of VDD and VDD.
- (2) Apply the LED voltage within the LCD operation range. When the back-light turns on before the LCD operation or the LCD turns off before the LEDs turns off, the display may momentarily become white.
- (3) In case of VDD = off level, please keep the level of input signals on the low or keep a high impedance.
- (4) T8 should be measured after the module has been fully discharged between power off and on period.
- (5) Interface signal shall not be kept at high impedance when the power is on.

7. Outline Dimension (TBD)

8. Packing (TBD)

9. MARKINGS & OTHERS

Preliminary

A nameplate bearing followed by is affixed to a shipped product at the
Specified location on each product.

9.1 Packing case attach

TBD

10. General Precautions

10.1. Handling

- (a) When the module is assembled, It should be attached to the system firmly using every mounting holes. Be careful not to twist and bend the modules.
- (b) Refrain from strong mechanical shock and / or any force to the module. In addition to damage, this may cause improper operation or damage to the module and LED back-light.
- (c) Note that polarizers are very fragile and could be easily damaged. Do not press or scratch the surface harder than a HB pencil lead.
- (d) Wipe off water droplets or oil immediately. If you leave the droplets for a long time, Staining and discoloration may occur.
- (e) If the surface of the polarizer is dirty, clean it using some absorbent cotton or soft cloth.
- (f) The desirable cleaners are water, IPA(Isopropyl Alcohol) or Hexane. Do not use Ketone type materials(ex. Acetone), Ethyl alcohol, Toluene, Ethyl acid or Methyl chloride. It might permanent damage to the polarizer due to chemical reaction.
- (g) If the liquid crystal material leaks from the panel, it should be kept away from the eyes or mouth . In case of contact with hands, legs or clothes, it must be washed away thoroughly with soap.
- (h) Protect the module from static , it may cause damage to the CMOS IC.
- (i) Use finger-stalls with soft gloves in order to keep display clean during the incoming inspection and assembly process.
- (j) Do not disassemble the module.
- (k) Do not adjust the variable resistor which is located on the back side.
- (l) Protection film for polarizer on the module shall be slowly peeled off just before use so that the electrostatic charge can be minimized.
- (m) Pins of I/F connector shall not be touched directly with bare hands.

10.2 Storage

- (a) Do not leave the module in high temperature, and high humidity for a long time.
It is highly recommended to store the module with temperature from 0 to 35 °C and relative humidity of less than 70%.
- (b) Do not store the TFT-LCD module in direct sunlight.
- (c) The module shall be stored in a dark place. It is prohibited to apply sunlight or fluorescent light during the store.

10.3 Operation

- (a) Do not connect, disconnect the module in the “ Power On” condition.
- (b) Power supply should always be turned on/off by following item 6.5 “ Power on/off sequence “.
- (c) Module has high frequency circuits. Sufficient suppression to the electromagnetic interference shall be done by system manufacturers. Grounding and shielding methods may be important to minimize the interference.

10.4 Others

- (a) Ultra-violet ray filter is necessary for outdoor operation.
- (b) Avoid condensation of water. It may result in improper operation or disconnection of electrode.
- (c) Do not exceed the absolute maximum rating value. (the supply voltage variation, input voltage variation, variation in part contents and environmental temperature, so on)
Otherwise the module may be damaged.
- (d) If the module displays the same pattern continuously for a long period of time, it can be the situation when the image “sticks” to the screen.
- (e) This module has its circuitry FPC's on the rear side and should be handled carefully in order not to be stressed.