

Smart Li-Ion Battery Gas Gauge

PRODUCT SUMMARY

- Accurately measures available charge in Li-Ion batteries
- Provides 14-bit resolution for voltage, temperature, and current measurements
- Controls the MOSFETs used in the Li-Ion protection circuit

FEATURES

- Supports SBS Smart Battery Data Specification v1.1
- Supports the 2-wire SMBus v1.1 interface with PEC
- Reports individual cell voltages
- Monitors and provides control to charge and discharge the MOSFETs used in a Li-Ion protection circuit

 **Pb-free, RoHS compliant.**

- Provides cell balance control output for charge control.
- Consumes less than 1.5mW during operation
- Drives a 4- or 5-segment LED display for indication of remaining capacity
- Narrow (150-mil) SSOP-28

GENERAL DESCRIPTION

The SS4002AG is an SBS-compliant gas gauge IC for battery pack or in-system installation. It maintains an accurate record of available charge in rechargeable batteries. The SS4002AG is designed specifically for Li-Ion batteries, and monitors capacity and other critical battery parameters. The SS4002AG uses an A-to-D converter with automatic offset error correction for voltage, temperature, and current reporting. The cumulated charge into (or discharge from) the battery is continuously calculated. The onboard ADC also monitors individual cell voltages in the battery pack and allows the SS4002AG to generate control signals that may be used in conjunction with a pack supervisor to enhance pack safety.

The SS4002AG supports the smart battery data (SBData) commands and charge-control functions. It communicates data using the 2-wire System Management Bus (SMBus). The data available includes the battery's remaining capacity, temperature, voltage,

current, and remaining run-time predictions.

The SS4002AG provides drive pins for LEDs to depict remaining battery capacity from full to empty in 20% or 25% increments with a 4 or 5-segment display.

The SS4002AG works with an external EEPROM. The EEPROM stores the configuration information for the SS4002AG, such as the self-discharge rate, measurement calibration, and design voltage and capacity.

The SS4002AG uses the programmable self-discharge rate and other compensation factors stored in the EEPROM to accurately adjust remaining capacity for use and standby conditions based on time, rate, and temperature. The SS4002AG also automatically calibrates or learns the true battery capacity in the course of a discharge cycle from near full to near empty levels.

The VREF output regulates the operating voltage for the SS4002AG from the battery cell stack using an external MOSFET.

PIN CONFIGURATION

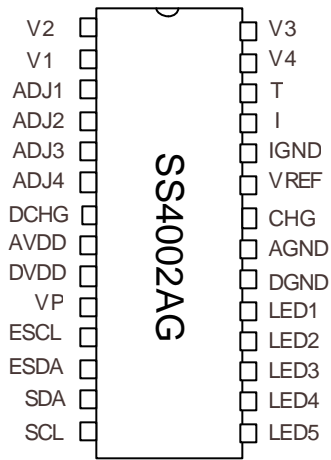

28-Pin Narrow SOIC

V2	Voltage from tip of cell 2	V3	Voltage from tip of cell 3
V1	Voltage from tip of cell 1	V4	Voltage from tip of cell 4
ADJ1	Cell1 bypass control	T	Temperature sense resistor input
ADJ2	Cell2 bypass control	I	Current sense resistor input
ADJ3	Cell3 bypass control	IGND	Current sense resistor ground port
ADJ4	Cell 4 bypass control	VREF	Voltage reference output
DCHG	Discharge FET control output	CHG	Charge FET control output
AVDD	Analog VDD	AGND	Analog Ground
DVDD	Digital VDD (4.5V~5.5V)	DGND	Digital ground
VP	EEPROM supply output	LED1	LED segment (MSB)
ESCL	EEPROM clock (output)	LED2	LED segment
ESDA	EEPROM data (input/output)	LED3	LED segment
SDA	SMB data (input/output)	LED4	LED segment
SCL	SMB clock (input/output)	LED5	LED segment (LSB)

PIN DESCRIPTION

Pin Name	Pin No	I/O	Description
ADJ1	3	Input/Output ¹	Cell balance bypass control for cell 1 (Timer in for calibration)
ADJ2	4	Output ¹	Cell balance bypass control for cell 2
ADJ3	5	Output ¹	Cell balance bypass control for cell 3
ADJ4	6	Output ¹	Cell balance bypass control for cell 4
AGND	21	Input	Analog ground
AVDD	8	Input	Analog positive supply
CHG	22	Output	Charge MOSFET control output. High output to terminate charge
DCHG	7	Output	Discharge MOSFET control output. High output to terminate discharge
DGND	20	Input	Digital ground
DVDD	9	Input	Digital positive supply
ESCL	11	Output	EEPROM I ² C clock line
ESDA	12	Input/Output	EEPROM I ² C data line
I	25	Input ²	Current sense resistor battery negative terminal
IGND	24	Input	Current sense resistor ground (pack negative) terminal
LED1	19	Output ⁴	LED display segment (MSB)
LED2	18	Output ⁴	LED display segment
LED3	17	Output ⁴	LED display segment
LED4	16	Output ⁴	LED display segment
LED5	15	Output ⁴	LED display segment (LSB)
SCL	14	Input/Output	SMbus clock line
SDA	13	Input/Output	SMbus data line
T	26	Input ³	Temperature sense resistor voltage divider circuits terminal
V1	2	Input ³	Divided voltage input from cell 1 (the cell connect to battery negative terminal)
V2	1	Input ³	Divided voltage input from cell 2
V3	28	Input ³	Divided voltage input from cell 3
V4	27	Input ³	Divided voltage input from cell 4 (highest voltage)
VP	10	Output	EEPROM positive supply
VREF	23	Output	Voltage regulator's voltage reference output

Note 1: Input/outputs are TTL compatible level.

Note 2: Input voltage range is -160mV to +80mV.

Note 3: Divided voltage input range should be from 0.5V to 3.5V.

Note 4: Open drain output.

Voltage Thresholds

In conjunction with monitoring the voltage at the I pin for charge/discharge currents, the SS4002AG also monitors the battery potential through the V pin. The voltage potential is determined through a resistor-divider network on tips of cells. The dividing factors of networks are calculated during calibration and saved in the EEPROM. The battery voltage is obtained by measuring the input voltages on tips of cells and dividing factors stored in EEPROM. The battery voltage is monitored for battery LOW and battery EXHAUSTED (PLV and PEV). An alarm warning will be sent to the host when battery voltage is lower than PLV or PEV. Both PLV and PEV are dynamically adjusted according to present load and temperature. Exhausting charge threshold levels are used to determine when the battery has reached a programmable “empty” state. If the discharge current is greater than the overload current value stored in the EEPROM, PLV monitoring is disabled and resumes after the current falls below the programmed value.

Reset

The SS4002AG is in reset state when either first connected to the battery pack or receiving a RESET command from SMBus. Two categories of reset command, hard reset and soft reset, are acceptable from the SMBus. On hard reset, the SS4002AG initializes and reads the EEPROM to configure the battery pack. On soft reset, the SS4002AG keeps the current state of battery. The soft-RESET command is a byte command with command code 0xF5. The hard-RESET command is sent through manufacturer access data 0404.

Sleep mode

The SS4002AG switches into sleep mode after detecting no charge flow-through for more than 240 seconds. In the sleep mode, most of the logic circuitry in the chip is turned off to minimize the power consumption. SS4002AG will be awakened by either receiving an SBD command or detecting a current flow through the sense resistor.

Measurement Operation

The SS4002AG accumulates a measure of charge and discharge currents, and estimates self-discharge. Charge currents are compensated for temperature and state-of-charge of the battery. The battery capacity, denoted as Remaining Capacity (RCAP) in terms of either current or power, represents the available battery capacity at any given time. The charging increments the RCAP, while the discharging and self-discharging decrement the RCAP. An internal register is used to accumulate the amount of discharge to adjust the Full Charge Capacity (FCCAP). FCCAP is updated only if a complete battery discharges from full to empty occurs without any partial battery charges. Therefore, the SS4002AG adapts its capacity determination based on the actual conditions of discharge. The battery's initial full capacity is set to the value stored in EEPROM. Until

FCCAP is updated, RCAP counts up to, but not beyond, this threshold during subsequent charges. The battery's empty state is also programmed in the EEPROM. The battery-low percentage stores the percentage of FCCAP while the battery voltage drops to the PLV threshold.

1. Full Charge Capacity (FCCAP):

FCCAP is the latest measured discharge capacity of the battery. On initialization, FCCAP is set to the value stored in the EEPROM. During subsequent discharges, FCCAP is updated with the latest recognized complete discharging (or learning cycle), representing a discharge from full to PLV, plus the battery low amount. A learning cycle is necessary to update the FCCAP register. The FCCAP also serves as the 100% reference threshold used by the relative state-of-charge calculation and display.

2. Design Capacity (DCAP):

The DCAP is the user-specified battery capacity and is programmed in the external EEPROM. The DCAP also provides the 100% reference for the absolute state-of-charge calculation.

3. Remaining Capacity (RCAP):

RCAP counts up during charge to a maximum value of FCCAP and counts down to 0 during discharge and self-discharge. RCAP is set to the battery low amount after the PLV threshold has been reached. If RCAP is equal to the battery low amount, RCAP keeps until voltage drops below PLV threshold. To prevent overstatement of charge during periods of overcharge, RCAP stops incrementing when RCAP = FCCAP.

4. Cumulated Discharge Count (CDC):

The Cumulated Discharge Count is used to record the usage of the battery which relates to the life of battery. The CDC counts up during discharge independent of RCAP and can continue increasing after RCAP has decremented to 0. The CDC resets to 0 when CDC = DCAP and the Cycle Count will be increased by 1.

Charge Counting

Charge activity is detected based on a positive voltage on the I input. The voltage input at the I input is measured and converted into current through the sense resistor. If charge activity is detected, the SS4002AG increases the RCAP. Charge actions increment the RCAP according to the cumulated charge counts. If the measured current is lower than the threshold of the digital filter and the digital filter is enabled, the charge current is set as zero.

Discharge Counting

Discharge activity is detected based on a negative voltage on the I input. The voltage input at the I input is measured and converted into current through the sense resistor. If discharge activity is detected, the SS4002AG decreases the RCAP. If the measured current is lower

than the threshold of the digital filter and both SMD and SMC are high, the discharge current is set to light discharge load. The threshold of the digital filter and light discharge load are stored in EEPROM.

Self-Discharge Estimation

The SS4002AG periodically decrements RCAP for self-discharge, until the charge-full or charge-empty condition is detected. The estimated self-discharge rate is programmed in EEPROM. The SS4002AG also adjusts the self-discharge rate based on the pack temperature.

Charge Control

The SS4002AG supports SBS charge control by

broadcasting the ChargingCurrent() and the ChargingVoltage() to the Smart Charger every 60 seconds. Broadcasting can be either suspended by setting bit 14 of BatteryMode to 1 or turned off in the Master functionality by clearing bit 2 of ControlMode. The SS4002AG updates the charging current broadcasting based on the battery's state of charge, voltage, and temperature. The SS4002AG uses current taper detection for Li-Ion primary charge termination and over voltage detection to suspend charging. The SS4002AG also provides a number of safety terminations based on battery capacity, voltage, temperature and conditions of individual cells.

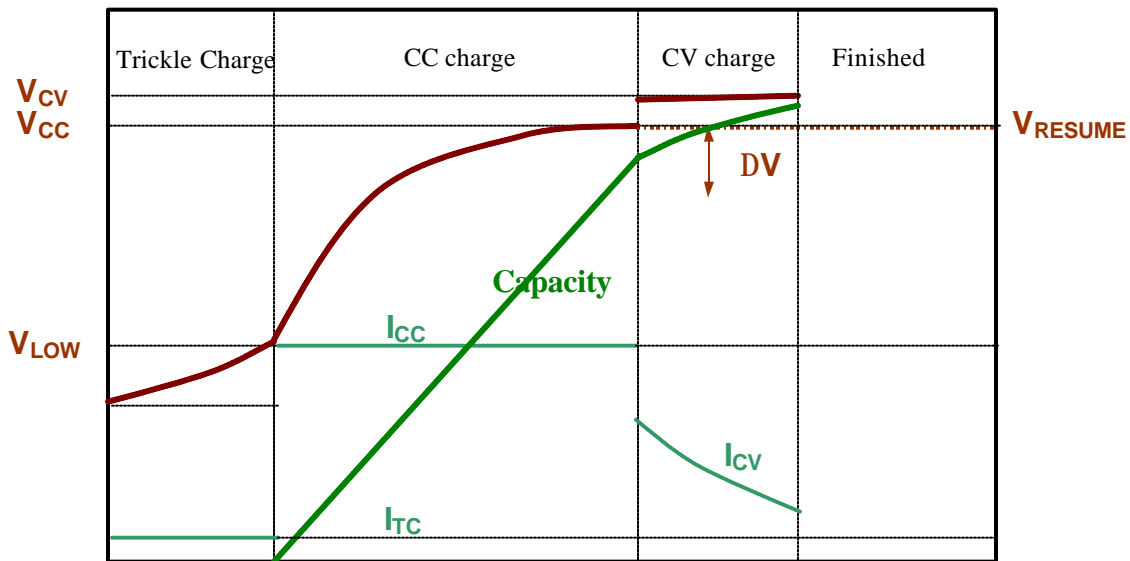

Figure 1. Charging control

Alarm Mode

If any of the bits 8-15 is set, SS4002AG broadcasts an AlarmWarning() message to the SMBus host. If any of the bits 12-15 is set, the AlarmWarning message is broadcast to the Smart Charger as well. The message sent by the AlarmWarning() function is the same as the message returned by the BatteryStatus() function, except for the lowest nibble (4 bits). The Smart Battery will continue broadcasting the AlarmWarning() messages at 10 second intervals until the critical condition(s) has been corrected. The AlarmWarning() message broadcasting can be suspended by setting bit 13 (AlarmMode) of BatteryMode or turned off by clearing bit 0 of ControlMode..

Cell Balancing

The SS4002AG balances the cells during charge by partially bypassing the charges through the bypass resistors for those cells above the bypass charge threshold set in EEPROM. The cell balancing ceases when voltages of all cells are over the bypass charge

threshold. Depending upon the control circuit in the gas gauge module, the cell balancing can be enabled/disabled through a control bit in the control mode register in EEPROM.

Digital Filter

The SS4002AG does not measure charge or discharge counts below the digital filter threshold. The digital filter threshold is programmed in the EEPROM and should be set sufficiently high to prevent false signal detection with no charge or discharge flowing through the sense resistor.

Current

The SS4002AG uses the voltage drops across the sense resistor to measure and calculate the battery charge and discharge current, and reports Current() in the data register.

Voltage

While monitoring charge and discharge currents, the SS4002AG monitors the individual series cell voltages.

SS4002AG also supports an optional function to report individual cell voltage measurements. Connecting tips of cells to SS4002AG pins, SS4002AG can measure voltage of each battery cell. The SS4002AG also provides line resistance correction factors, which are stored in the EEPROM, to accurately determine the individual cell voltage

Temperature

The SS4002AG monitors temperature sensing using an external thermistor. The temperature is used to adapt charge and self-discharge compensations as well as to monitor for maximum temperature. Temperature may be accessed over the SMBus with standard SBD command 0x08.

Calibration

SS4002AG provides calibration on the gauge board (module) for voltage, current and temperature measurement. After calibration, both slope and offset of each channel will be stored in the EEPROM. To calibrate the module, a calibration kit providing standard signals is required. As the A/D converter is affected by temperature, the current offset will keep adjusting during normal operation.

Display port

The display port drives low-power LEDs for a bar-graph display. Each LED segment represents 20% or 25% of the FCC determined by the LED bit in the ControlMode register stored in the EEPROM. The LED outputs are

active all the time.

SMBus Communication Protocol

The SS4002AG receives and transmits data with or without PEC. Figure 2 shows the communication protocol for the Read Word, Write Word, and Read Block messages without PEC. Figure 3 includes PEC. In the Write Word protocol, the slave device waits for the PEC after the last byte of data from the master device. If the master device does not support PEC, the last byte of data is followed by a STOP condition. After receipt of the PEC, the slave device compares the value to its calculation. If the PEC is correct, the slave device responds with an ACKNOWLEDGE. If it is not correct, the slave device responds with a NOT ACKNOWLEDGE and sets an error code.

SMBus commands from host

As an SMBus slave device, the SS4002AG accepts three types of SMBus protocol: read-word, write-word and read-block, according to the command send from the host. Table 1 shows the commands the SS4002AG accepts. All the commands (or register functions) proposed in the Smart Battery Data Specification (SBD) version 1.1 are implemented in the SS4002AG. In addition, other optional functions and non-standard commands are provided as well. All the non-standard commands and some of the manufacturer functions can be fixed.

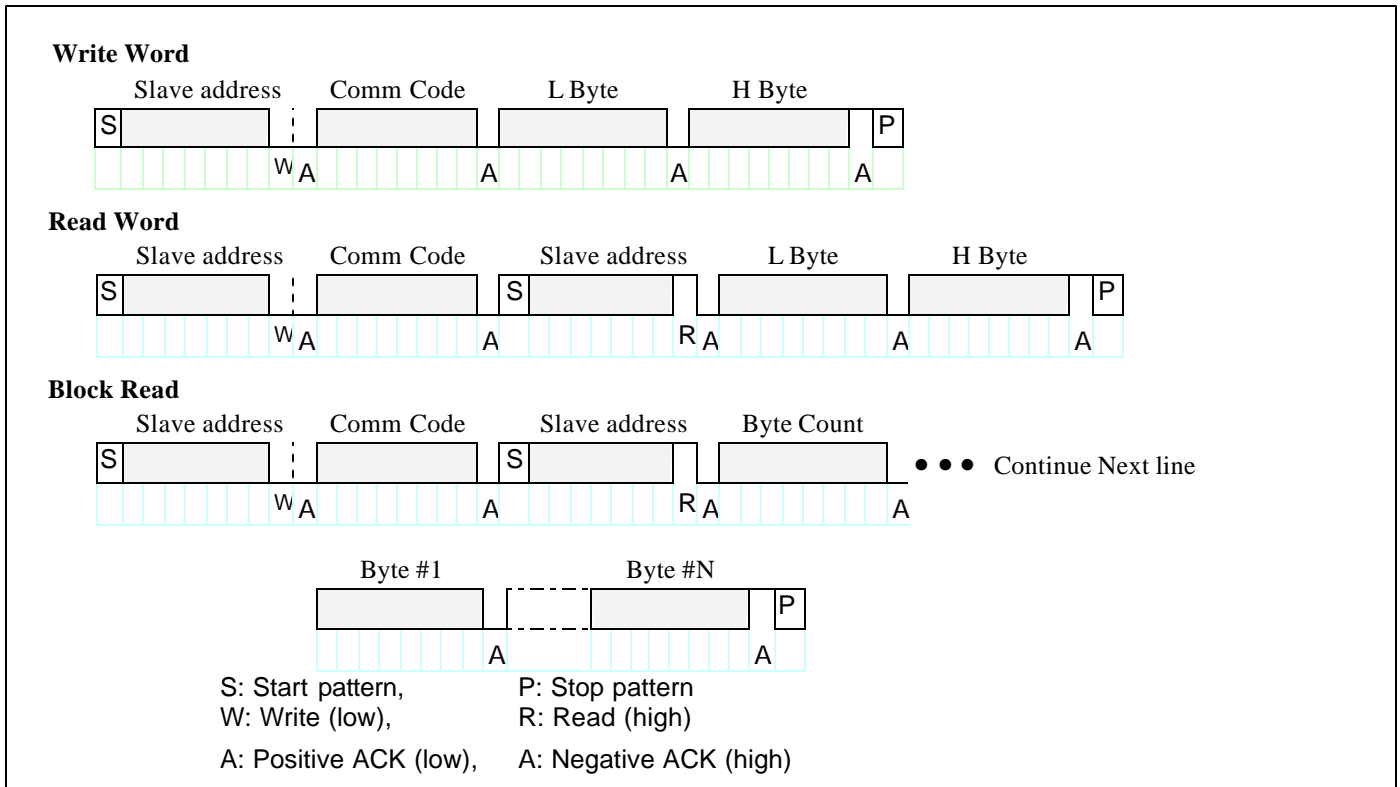

Figure 2. SMBus Communication Protocols without PEC

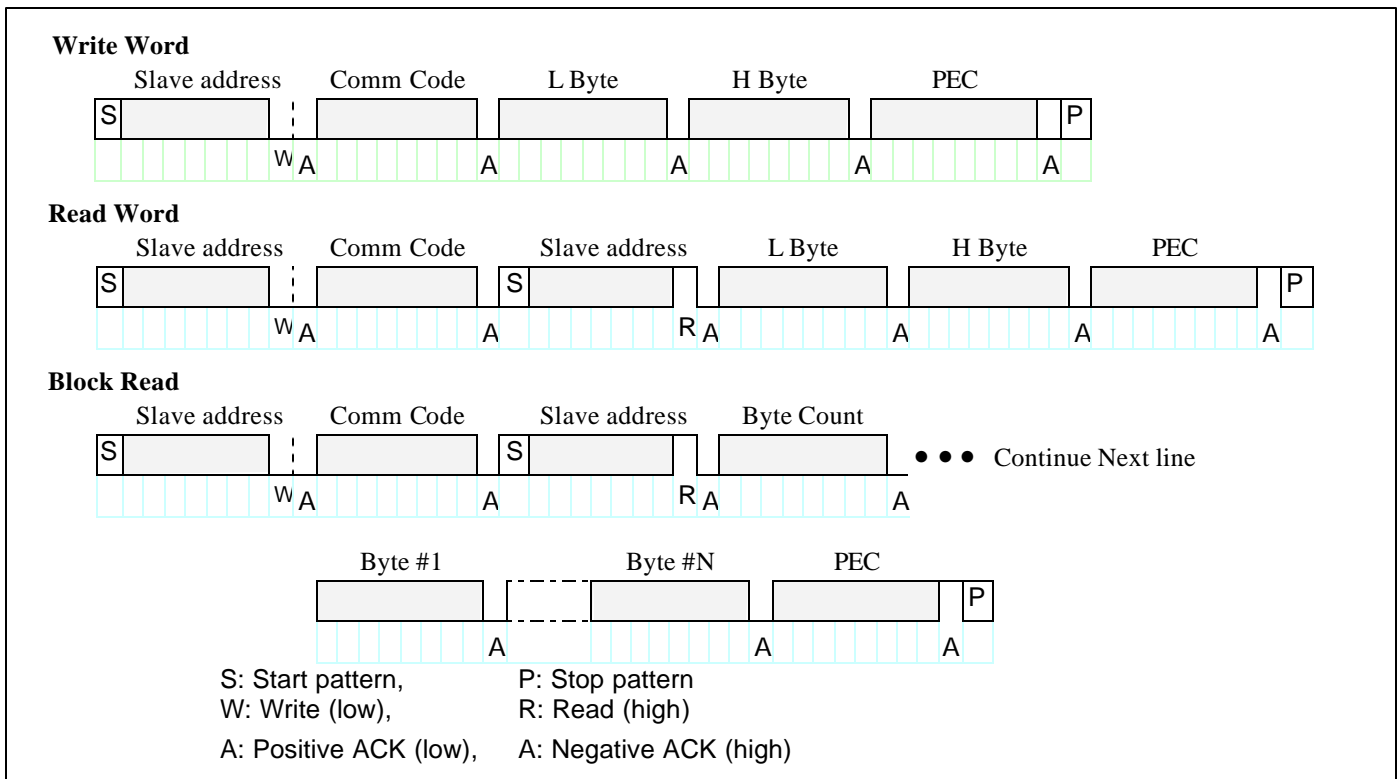

Figure 3. SMBus Communication Protocols with PEC

Table 1. Host-to-SS4002AG Commands

Function	Code	Access	Units	Initial value	Note
ManufacturerAccess	0x00	read/write	—	—	
RemainingCapacityAlarm	0x01	read/write	mAh	E ²	
RemainingTimeAlarm	0x02	read/write	minutes	E ²	
BatteryMode	0x03	read/write	bit flags	—	
AtRate	0x04	read/write	mA	—	
AtRateTimeToFull	0x05	read	minutes	—	
AtRateTimeToEmpty	0x06	read	minutes	—	
AtRateOK	0x07	read	Boolean	—	
Temperature	0x08	read	0.1°K	2980	
Voltage	0x09	read	mV	0	
Current	0x0a	read	mA	0	
AverageCurrent	0x0b	read	mA	0	
MaxError	0x0c	read	percent	0	
RelativeStateOfCharge	0x0d	read	percent	—	
AbsoluteStateOfCharge	0x0e	read	percent	—	
RemainingCapacity	0x0f	read	mAh	E ²	
FullCahrgeCapacity	0x10	read	mAh	E ²	
RunTimeToEmpty	0x11	read	minutes	—	
AverageTimeToEmpty	0x12	read	minutes	—	
AverageTimeToFull	0x13	read	minutes	—	
ChargingCurrent	0x14	read	mA	E ²	
ChargingVoltage	0x15	read	mV	E ²	
BatteryStatus	0x16	read	bit flags	—	
CycleCount	0x17	read	cycle	E ²	
DesignCapacity	0x18	read	mAh	E ²	
DesignVoltage	0x19	read	mV	E ²	
SpecificationInfo	0x1a	read	—	E ²	
ManufactureDate	0x1b	read	—	E ²	
SerialNumber	0x1c	read	integer	E ²	
Reserved	0x1d-0x1f	—	—	—	
ManufactureName	0x20	read	string	E ²	
DeviceName	0x21	read	string	E ²	
DeviceChemstry	0x22	read	string	E ²	
ManufacturerData	0x23	read	bit flags	E ²	
PackConfigure/Status	0x2f	read	bit flags	E ²	Note 1
Reserved	0x30~0x3b	—	—	—	
VCELL4	0x3c	read	mV	—	Note 1
VCELL3	0x3d	read	mV	—	Note 1
VCELL2	0x3e	read	mV	—	Note 1
VCELL1	0x3f	read	mV	—	Note 1
Reserved	0x40~0xef	—	—	—	
Download EEPROM	0xf0	write	—	—	Note 2
Reserved	0xf1-0xf4	—	—	—	
Reset SS4002A	0xf5	command	—	—	Note 2
Reserved	0xf6-0xff	—	—	—	

Note1: Optional manufacturer function

Note2: Not SBD standard function

ManufacturerAccess() (0x00)

This function provides means to control the SS4002AG during normal operation and pack manufacturing. The following commands are available.

- 01XX Engineer support command
 - 02XX Engineer support command
 - 03XX Calibration command:
 - 0404 Reset (cold start, can be sealed)
 - 05XX LED control command:
 - 0501: LED test
 - 0502: Normal mode
 - 06XX Engineer support command
- All the engineer support commands are used for maintenance support only.

Input/Output: Set command and get return value in certain sort of commands.

RemainingCapacityAlarm() (0x01)

This function sets or returns the remaining capacity alarm value. When RemainingCapacity falls below the RemainingCapacityAlarm value initialized from the external EEPROM, the RemainingCapacityAlarm bit is set in BatteryStatus. The system may alter this alarm during operation.

Input/Output: unsigned integer. This sets/returns the value where the RemainingCapacityAlarm bit is set in Battery Status.

Units: mAh/10mWh
Range: 0 to 65,535

RemainingTimeAlarm() (0x02)

This function sets or returns the remaining time alarm value. When the AverageTimeToEmpty falls below the RemainingTimeAlarm value initialized from EEPROM, the Remaining_Time_Alarm bit in BatteryStatus is set. The system may alter this alarm during operation.

Input/Output: unsigned integer. This sets/returns the value where the Remaining_Time_Alarm bit is set in Battery Status.

Units: minutes
Range: 0 to 65,535 minutes

BatteryMode() (0x03)

This read/write word selects the various battery operational modes. The lower byte is read-only, any input data will be no effects on the lower byte. The SS4002AG supports neither internal charge control nor primary battery support. Bit definition is shown in Table 2. Since bits 0 and 1 are 0s, bits 8 and 9 have no effect. The SS4002AG does support the battery capacity information specified in both mAh and 10mWh modes.

AtRate() (0x04)

This read/write word is the first half of a two-function set used to set the AtRate value used in calculations made by the AtRateTimeToFull() and AtRateTimeToEmpty(). When the AtRate value is positive, the AtRateTimeToFull function returns the predicted time to charge full at the AtRate value of charge. When the AtRate value is negative, the

AtRateTimeToEmpty function returns the predicted operating time until charge empty at the AtRate value of discharge.

Input/Output: signed integer. AtRate is positive for charge and negative for discharge.
Units: mA/10mW
Range: -32,768 to 32,767

AtRateTimeToFull() (0x05)

This read-only word returns the predicted remaining time to fully charge the battery at the AtRate value (mA). The calculation is according to the latest set of AtRate value.

Output: unsigned integer. Returns the predicted time to full charge.
Units: minutes
Range: 0 to 65,534
Invalid Data Indication: 65,535 indicate that the AtRate is a negative value.

AtRateTimeToEmpty() (0x06)

This read-only word returns the predicted remaining operating time if the battery is discharged at the AtRate value. The calculation is according to latest set of AtRate value.

Output: unsigned integer. Returns the predicted time to empty.
Units: minutes
Range: 0 to 65,534
Invalid Data Indication: 65,535 indicate that the AtRate is a positive value.

AtRateOK() (0x07)

This read-only word returns a Boolean value that indicates whether or not an additional load with AtRate (mA) can be provided for longer than 10 seconds.

Boolean: Indicates if the battery can supply additional energy with rate of AtRate (mA) for at least 10 seconds.
Units: Boolean
Range: TRUE ? 0, FALSE = 0

Temperature() (0x08)

This read-only word returns the battery pack's internal temperature.

Output: unsigned integer. Returns the cell temperature in tenths of degrees Kelvin increments.
Units: 0.1°K
Range: 0 to +500.0°K
Accuracy: ? 2°K after calibration

Voltage() (0x09)

This read-only word returns the battery pack voltage (mV).

Output: unsigned integer. Returns the battery terminal voltage in mV.
Units: mV
Range: 0 to 65,535mV
Accuracy: ? 1% of DesignVoltage after calibration

Table 2. Bit Definition of Battery Mode

Field	Bits Used	Access	Allowable Values
INTERNAL_CHARGE_CONTROLLER	0	R	0 – Function Not Supported
PRIMARY_BATTERY_SUPPORT	1	R	0 – Function Not Supported
Reserved	2-6		Undefined
RELEARN_FLAG	7	R	0 – Battery OK 1 – Capacity Re-Learn Cycle Required
CHARGE_CONTROLLER_ENABLED	8	R/W	No effect
PRIMARY_BATTERY	9	R/W	No effect
Reserved	10-12		Undefined
ALARM_MODE	13	R/W	0 – Enable Alarm Warning broadcasts to Host and Smart Battery Charger 1 – Disable Alarm Warning broadcasts to Host and Smart Battery Charger
CHARGER_MODE	14	R/W	0 – Enable Charging Voltage and Current broadcasts to Smart Charger 1 – Disable broadcasts of Charging Voltage and Current to Smart Charger
CAPACITY_MODE	15	R/W	0 – Report in mA or mAh 1 – Report in 10mW or 10mWh

Current() (0x0a)

This read-only word returns the current through the battery's terminals (mA).

Output: signed integer. Returns the charge/discharge rate in mA, where positive is for charge and negative is for discharge.

Units: mA

Range: 0 to 32,767mA for charge or 0 to –32,768mA for discharge

Accuracy: ? 1% of the DesignCapacity after calibration

AverageCurrent() (0x0b)

This read-only word returns a rolling average of the current through the battery's terminals. The AverageCurrent function returns meaningful values after the battery's first minute of operation.

Output: signed integer. Returns the charge/discharge rate in mA, where positive is for charge and negative is for discharge

Units: mA

Range: 0 to 32,767mA for charge or 0 to –32,768mA for discharge

Accuracy: ? 1% of the DesignCapacity after calibration

MaxError() (0x0c)

Returns the expected margin of error (%) in the state of charge calculation.

Output: unsigned integer. Returns the percent uncertainty for selected information.

Units: %

Range: 0 to 100%

RelativeStateOfCharge() (0x0d)

This read-only word returns the predicted remaining battery capacity expressed as a percentage of FullChargeCapacity (%).

Output: unsigned integer. Returns the percent of remaining capacity.

Units: %

Range: 0 to 100%

Accuracy: ? MaxError after circuit and capacity calibration

AbsoluteStateOfCharge() (0x0e)

This read-only word returns the predicted remaining battery capacity expressed as a percentage of DesignCapacity (%). Note that AbsoluteStateOfCharge can return values greater than 100%.

Output: unsigned integer. Returns the percent of remaining capacity.

Units: %

Range: 0 to 65,535%

Accuracy: ? MaxError after circuit and capacity calibration

RemainingCapacity() (0x0f)

This read-only word returns the predicted remaining battery capacity.

Output: unsigned integer. Returns the estimated remaining capacity in mAh or 10 mWh.

Units: mAh/10mWh

Range: 0 to 65,535

Accuracy: ? MaxError × FCC after circuit and capacity calibration

FullChargeCapacity() (0x10)

This read-only word returns the predicted pack capacity when it is fully charged. FullChargeCapacity defaults to the value programmed in the external EEPROM until a new pack capacity is learned. The new FullChargeCapacity is valid only if which is no less than 90 percent of the previous FullChargeCapacity.

Output: unsigned integer. Returns the estimated full charge capacity.

Units: mAh/10mWh

Range: 0 to 65,535mAh
Accuracy: ? MaxError × FCC after circuit and capacity calibration

RunTimeToEmpty() (0x11)

This read-only word returns the predicted remaining battery life at the present rate of discharge (minutes). The RunTimeToEmpty value is calculated based on Current.

Output: unsigned integer. Returns the minutes of operation left.

Units: minutes

Range: 0 to 65,534min

Invalid data indication: 65,535 indicate battery is being charged.

AverageTimeToEmpty() (0x12)

This read-only word returns the predicted remaining battery life at the present average discharge rate (minutes). The AverageTimeToEmpty is calculated based on AverageCurrent.

Output: unsigned integer. Returns the minutes of operation left.

Units: minutes

Range: 0 to 65,534min

Invalid data indication: 65,535 indicate battery is being charged.

AverageTimeToFull() (0x13)

This read-only word returns the predicted time until the Battery reaches full charge at the present average charge rate (minutes).

Output: unsigned integer. Returns the remaining time in minutes to full.

Units: minutes

Range: 0 to 65,534min

Invalid data indication: 65,535 indicate battery is not being charged.

ChargingCurrent() (0x14)

This read-only word returns the desired charging rate in mA. If ChargeMode is enabled, the SS4002AG uses this command to send the desired charging rate to smart charger and SMBus Host.

Output: unsigned integer. Transmits/returns the desired charger output current in mA.

Units: mA

Range: 0 to 65,534mA

ChargingVoltage() (0x15)

This read-only word returns the desired charging voltage in mV. If ChargeMode is enabled, the SS4002AG uses this command to send the desired charging voltage to smart charger and SMBus Host.

Output: unsigned integer. Transmits/returns the charger voltage output in mV.

Units: mV

Range: 0 to 65,534mV

BatteryStatus() (0x16)

This read-only word returns the battery status word.

Output: unsigned integer. Returns the bitmap of status and alarm register as shown in Table 3.

Table 3. Bit Definition of Battery Status

Field	Bits Used	Access	Set Condition
Alarm Bits—Over Charged	15	R	Battery is fully charged and charging is complete
Alarm Bits---Terminate Charge	14	R	Charging should be suspended temporarily
Reserved	13	R	
Alarm Bits---Over Temperature	12	R	Temperature is above pre-set limit
Alarm Bits---Terminate	11	R	Battery capacity is depleted
Reserved	10	R	
Alarm Bits---Remaining Capacity	9	R	Value of RemainingCapacity() is less than the value of RemainingCapacityAlarm()
Alarm Bits---Remaining Time	8	R	Value of AverageTimeToEmpty() is less than the value of RemainingTimeAlarm()
Status Bits---Initialized	7	R	Battery electronics are calibrated and valid EEPROM data
Status Bits---Discharging	6	R	Battery is discharging
Status Bits---Fully Charged	5	R	Battery is full and further charge is not required
Status Bits---Fully Discharged	4	R	Battery capacity is depleted
Error Codes	3-0	R	0--- No error

CycleCount() (0x17)

This read-only word returns the number of charge/discharge cycles the battery has experienced. A cycle is defined as an amount of discharge approximately equal to the value of DesignCapacity.

Output: unsigned integer. Returns the count of charge/discharge cycles the battery has experienced.
Units: cycles

Range: 0 to 65,535 cycles; 65,535 indicates battery has experienced 65,535 or more cycles.

DesignCapacity() (0x18)

This read-only word returns the theoretical capacity of a new pack. The DesignCapacity value is expressed in mAh at the nominal discharge rate.

Output: unsigned integer. Returns the battery capacity in mAh or 10mWh.

Units: mAh/10mWh

Range: 0 to 65,535

DesignVoltage() (0x19)

This read-only word returns the theoretical voltage of a new pack in mV.

Output: unsigned integer. Returns the battery's normal terminal voltage in mV.

Units: mV

Range: 0 to 65,535mV

SpecificationInfo() (0x1a)

This read-only word returns the specification revision the SS4002AG supports.

ManufactureDate() (0x1b)

This read-only word returns the date the cell was manufactured in a packed integer word. The date is packed as follows: (year – 1980) ×312 + month ×32 + day.

SerialNumber() (0x1c)

This read-only word returns a serial number. This number, when combined with the ManufacturerName, the DeviceName, and the ManufactureDate, uniquely identifies the battery.

Output: unsigned integer

ManufacturerName() (0x20)

This read-only string returns a character string where the first byte is the number of characters available. The maximum number of characters is 15. The character string contains the battery manufacturer's name. For example, "J-Tek" identifies the battery pack manufacturer as J-Tek.

Output: string or ASCII character string

DeviceName() (0x21)

This read-only string returns a character string where the first byte is the number of characters available. The maximum number of characters is 15. The character string contains the battery's name. For example, a DeviceName of "SS4002AG" indicates that the battery is a model of SSC.

Output: string or ASCII character string

DeviceChemistry() (0x22)

This read-only string returns a character string where the first byte is the number of characters available. The maximum number of characters is 5. The 5-byte character string contains the battery's chemistry. The SS4002AG supports Li-Ion type battery cells only.

Output: string or ASCII character string

ManufacturerData() (0x23)

This read-only string allows access to an up to 5-byte manufacturer data string.

Output: block data – data whose meaning is assigned by the Smart Battery's manufacturer.

PackConfigure/Status (0x2f)

This read-only register returns an unsigned integer representing the pack configuration and current status of the battery pack. The MSB represents pack configuration and the LSB represents the pack status. See Table 4 and Table 5 for the bit description for PackConfigure and PackStatus.

VCELL4 (0x3c)

This read-only word returns the measured voltage of the battery cell 4.

Output: The battery cell4 output voltage in mV.

Units: mV

Range: 0 to 65,535mV

Accuracy: ? 1% of DesignVoltage after calibration

VCELL3 (0x3d)

This read-only word returns the measured voltage of the battery cell 3.

Output: The battery cell3 output voltage in mV.

Units: mV

Range: 0 to 65,535mV

Accuracy: ? 1% of DesignVoltage after calibration

VCELL2 (0x3e)

This read-only word returns the measured voltage of the battery cell 2.

Output: The battery cell2 output voltage in mV.

Units: mV

Range: 0 to 65,535mV

Accuracy: ? 1% of DesignVoltage after calibration

VCELL1 (0x3f)

This read-only word returns the measured voltage of the battery cell 1.

Output: The battery cell1 output voltage in mV.

Units: mV

Range: 0 to 65,535mV

Accuracy: ? 1% of DesignVoltage after calibration

Download EEPROM (0xf0)

This download command is designed for writing data into *EEPROM*. Download data from Control PC through SMBus will be relayed by SS4002AG to send to onboard *EEPROM* via I²C bus. To protect data in *EEPROM* against illegal access or unintentional updating, an access code is required following the command code "0xf0". Operation procedure in detail, please refer to "Operation procedure for calibration and download".

Reset (0xf5)

This reset command provides the system user a manner to reset the pack when unexpected condition occurs. Operation procedure in detail, please refer to "Operation procedure for calibration and download".

Table 4. Bit definitions of PackConfigure

-	SEAL	-	CPLV	VCOR	CHEM	LCC1	LCC0
7	6	5	4	3	2	1	0

- bit 7: Not used.
1: no effect
0: no effect
- bit 6: SEAL
1: Sealed, Commands from ManufacturerAccess() are disabled
0: Not Sealed
- bit 5: Not used
1: no effect
0: no effect
- bit 4: CPLV, Pack Low(Exhausted) Voltage compensation base on load and temperature.
1: Enable compensation
0: Disable compensation
- bit 3: VCOR: Mid-range capacity correction with pack voltage
1: Enable mid-range correction
0: Disable mid-range correction
- bit 2: CHEM.
1: no effect
0: Li-Ion chemistry (default)
- bit 1,0: LCC1/LCC0.
0, 0: Pack Stack (No cell voltage)
0, 1: 2-serial pack
1, 0: 3-serial pack
1, 1: 4-serial pack

Table 5. Bit definitions of PackStatus

—	BL	VCurr	VDP	CO _n	DO _n	CVOV	CVUV
7	6	5	4	3	2	1	0

- bit 7: Reserved.
- bit 6: BL indicates that a Battery Low condition was detected
1: Battery voltage was detected below Package Low Vdtage(PLV).
0: No Battery Low condition was detected.
- bit 5: VCurr (Valid Current) is detected
1: $|I| > I_{VALID}$.
0: $|I| \leq I_{VALID}$
- bit 4: VDP is set when a valid discharge period is on going.
1: Valid discharge period is on going
0: Not a valid discharge period
- bit 3: CO_n (Charge FET On) is set when charging is allowed.
1: Charge FET On
0: Charging is not allowed
- bit 2: DO_n (Discharge FET On) is set when the discharge from battery pack is determined to be safety
1: Discharge FET On
0: Discharge FET Off
- bit 1: CVOV (Cell Voltage Over Voltage) is set when battery pack/cell voltage is detected as over predefined value
1: Over Voltage
0: Normal
- bit 0: CVUV (Pack Voltage Under Voltage) is set when pack voltage is detected as below lower .boundary
1: Under Voltage
0: Normal

Table 6. Bit definitions of ControlMode

NDF	CB	HPE	CPE	LED	COFF	CMOD	SM
7	6	5	4	3	2	1	0

- bit 7: NDF: disables the digital filter during discharge if the SMBC and SMBD lines are high.
 1: Digital filter enable all the time.
 0: Disable digital filter
- bit 6: CB: Enable the charge balance control mechanism.
 1: Adjust cell voltage while charge unbalance condition was detected during charging
 0: No balance adjustment during charging.
- bit 5: HPE: Enables/Disables PEC transmissions to the Smart Battery host for master mode alarm messages.
 1: PEC byte on broadcasts to host (Not supported)
 0: No PEC byte on broadcasts to host (default)
- bit 4: CPE: Enables/Disables PEC transmissions to the Smart Battery Charger for master mode alarm messages.
 1: PEC byte on broadcasts to charger (Not supported)
 0: No PEC byte on broadcasts to charger (default)
- bit 3: LED: The LED bit configures the SS4002AG for 4 or 5 LED indication.
 1: Selects the 4 LED indication mode
 0: Selects the 5 LED indication mode
- bit 2: COFF: Zero current reference selection.
 1: Selects the IGND reading. (suggest)
 0: Selects the calibrated I_{bias}.
- bit 1: CMOD: Charge mode selection
 1: Send CC and CV command to host
 0: Report charge voltage and charge current to host.
- bit 0: SM: The SM bit enables/disables master mode broadcasts by the SS4002AG
 1: Broadcasts to host and charger disabled
 0: Broadcasts to host and charger enabled

SMBus commands to host and smart charger

The SS4002AG can act as master to broadcast warning message to SMBus Host and broadcast charge commands to smart charger with write-word protocol.

Programming the SS4002AG

The SS4002AG requires the programming of an external EEPROM for proper device operation. Each module can be calibrated for the greatest accuracy, or general default values can be used. The calibration kit (including calibration board, software, and cable) for the Windows system is available. The SS4002AG uses a 24LC02 or equivalent serial EEPROM (capable of read operation to 2.0V) for storing various initial values, calibration data, and string information.

Table 7 and Table 8 detail the contents and show typical program values for a 3600mAh, 4-series Li-Ion battery pack, using a 20mΩ sense resistor.

Table 7. Programming the EEPROM

Name	Address		HEX Content		Example Value	Description
	Low	High	Low	High		
EEPROM valid	0x00		0x53		'S'	To indicate that valid data in EEPROM
EEPROM check	0x01		0x54		'T'	To indicate that external calibration has been done
Remaining Time Alarm	0x02	0x03	0x0a	00	10 min	The time alarm value.
Remaining Capacity Alarm	0x04	0x05	0xf0	00	240mAh	The low capacity alarm threshold value.
Cycle Count	0x06	0x07	00	00	0	The number of cycles the battery has experienced.
Design Capacity	0x08	0x09	0x60	0x09	3600mAh	The theoretical capacity of the new pack.
Pack Exhausted Voltage (PEV)	0x0a	0x0b	0x20	0xd1	12000mV	Battery exhausted detection threshold level. The pack is assumed to be exhausted, when the pack output voltage is below this value. The value programmed is the two's complement of the threshold voltage in mV.
Pack Low Check Voltage (PLCV)	0x0c	0x0d	0x20	0xd1	12000mV	Battery pack voltage checkpoint beyond PEV (3%). The value programmed is the two's complement of the threshold voltage in mV.
Pack Low Voltage (PLV)	0x0e	0x0f	0x88	0xc8	14200mV	Battery pack voltage at battery low. The value programmed is the two's complement of the threshold voltage in mV.
Full Charge Capacity	0x10	0x11	0xb8	0x0b	3000mA	This value sets the estimated pack capacity. This value will be updated when a complete learning cycle is experienced.
Remaining Capacity	0x12	0x13	0xe8	0x03	1000mAh	Current battery remaining capacity. This value will be reset when pack exhausted condition is detected.
Reserved	0x14	0x15	0	0		Should be programmed to zero .
Reserved	0x16	0x17	0	0		
Taper current	0x18	0x19	0xF0	00	240mA	The upper limit of charge current for Li-Ion charge termination.
ΔV_{POV}	0x1a		0x80		128mV	This value sets the voltage range for over voltage decision (w.r.t. Charge Voltage).
ΔV_{TAPER}	0x1b		0xff		255mV	This value sets the voltage range for current taper decision (w.r.t. Charge Voltage)
ΔV_{PCC}	0x1c		0xff		255mV	Voltage range (from Charge Voltage) for Constant Voltage charge. (This value also used as the pack voltage range for charge resume after fully charged)
Full-charge percentage	0x1d		0x62		98%	The ratio of the full charge capacity in RM when the SS4002AG determines a full-charge termination. If RM is below this value, RM is set to this value. If RM is above this value, the RM is not adjusted.

Name	Address		HEX Content		Example Value	Description
	Low	High	Low	High		
Pack Configuration	0x1e		0x03		3	Refer to Table 4.
Control Mode	0x1f		0x00		0	Refer to Table 6.
Battery Mode	0x2a	0x2b	0x00	0x40	16384	Battery Mode, Lower byte is read only; Upper byte can be modified.
Design Voltage	0x2c	0x2d	0xd0	0x39	14800mV	Nominal battery pack output voltage
Charging Voltage	0x2e	0x2f	0xa0	0x41	16800mV	The suggested fast-charge voltage for the Smart Charger
Fast-Charging Current	0x38	0x39	0x60	0x09	2400mA	The suggested fast-charge current for the Smart charger
Pre-Charge Current	0x3a	0x3b	0x2c	01	300mA	The desired Pre-charge current before normal (fast) charge
Heavy load Current	0x3c	0c3d	0x70	0x17	6000mA	Sets the discharge current at which EDV threshold monitoring is disabled
Maximum Cell Voltage	0x3e	0x3f	0x00	0x00	4200mV	
Self-Discharge Rate	0x46		0x05		0.1%	The desired self-discharge rate per day (%) at room temperature; 0.02% per unit (15 * 0.02 = 0.3)
A/D Calibration	0x47		0x00		0	A/D converter calibration data.
ΔV_{COV}	0x48		0x1e		30mV	This value sets the cell voltage range for over voltage decision (w.r.t. Maximum cell voltage)
ΔV_{RESUME}	0x49		32		50mV	This value sets the cell voltage range for charge resume after fully charged (w.r.t. maximum cell voltage)
Timer Counter	0x4a	0x4b	0xb0	0x3c	15536	Timer1 clock count for 200ms (65536 – 200000/(2*2)) For the RC inaccuracy, this value is to be tuned for precise 200ms period (pre-scale 2:1, 500kHz)
Maximum Temperature and DeltaT	0x4c		0x58		MaxT = 61°C DeltaT = 1.2°C	Maximum charge temperature is 69-(un*1.6) °C (un = upper nibble). The delta temperature is (ln *0.15)°C (ln = lower nibble)
BatteryLow%	0x4d		0x24		7%	Sets the battery capacity that Remaining capacity is reduced to at the Pack Low Voltage (PLV). The value equals 5.12*(%RM at PLV)
Reserved	0x4e	0x4f	0x00	0x00	0	Should be programmed to zero.
Reserved	0x56	0x57	0x00	0x00	0	Should be programmed to zero.
VOC25	0x58	0x59	0x90	0x38	14480mV	Voltage of Capacity 25%
VOC50	0x5a	0x5b	0x20	0x3a	14880mV	Voltage of Capacity 50%
VOC75	0x5c	0x5d	0xf0	0x3c	15600mV	Voltage of Capacity 75%
Reserved	0x5e	0x5f	0x00	0x00	0	Should be programmed to zero.
Calibration result	0x60	0x61				Calibration result.
Calibration result	0x62	0x63				Calibration result.
Calibration result	0x64					Calibration result.
Calibration result	0x65					Calibration result.
Calibration result	0x66					Calibration result.
Calibration result	0x67					Calibration result.
Calibration result	0x68					Calibration result.
Calibration result	0x69					Calibration result.
Calibration result	0x6a					Calibration result.
Calibration result	0x6b					Calibration result.
Calibration result	0x6c					Calibration result.
Calibration result	0x6d					Calibration result.

Name	Address		HEX Content		Example Value	Description
	Low	High	Low	High		
Calibration result	0x6e	0x6f				Calibration result.
Segmental Resistance 1	0x70		2		2mΩ	Resistance between tips of Battery cell 1 and Sense Resistor
Segmental Resistance 2	0x71		2		2mΩ	Resistance between tips of Battery cell 1 and cell 2
Segmental Resistance 3	0x72		2		2mΩ	Resistance between tips of Battery cell 2 and cell 3
Segmental Resistance 4	0x73		2		2mΩ	Resistance between tips of Battery cell 3 and cell 4
Sense Resistor	0x74		0x14		20mΩ	Sense resistor value in mΩ
Digital Filter current	0x75		0xa		10mA	Dead Zone Margin for A/D converter
Light Load Current	0x76		0x02		2mA	Light load current, active only when digital filter disabled.
Reserved	0x77		0x00		0	Should be programmed to zero.
Specification information	0x78	0x79	0x 10	0x10	1.1	Packed data to the version of SBD spec. SS4002AG supports.
Manufacturer Date	0x7a	0x7b	0xa1	0x20	May, 1, 1996	The manufacture date of the cell pack. This value is a packed integer
Serial number	0x7c	0x7d	0x12	0x27	10002	An optional pack serial number
Reserved	0x7e	0x7f	0x00	0x00		Should be programmed to zero.
Calibration result	0x80					Calibration result.
Calibration result	0x81					Calibration result.
Calibration result	0x82					Calibration result.
Calibration result	0x83					Calibration result.
Calibration result	0x84					Calibration result.
Reserved	0x85					Should be programmed to zero.
Reserved	0x86	0x87				Should be programmed to zero.
Calibration result	0x88					Calibration result.
Calibration result	0x89					Calibration result.
Calibration result	0x8a					Calibration result.
Calibration result	0x8b					Calibration result.
Calibration result	0x8c					Calibration result.

Table 8. String data in EEPROM

String description	Manufacturer name		Device name		Device chemistry		Manufacturer data	
	0x2n	0xA _n	0x3 _n	0xB _n	0x4 _n	0xC _n	0x5 _n	0xD _n
0	Length	Length	Length	Length	Length	Length	Length	Length
1	Character 1	Character 1	Character 1	Character 1	Character 1	Character 1	Character 1	Character 1
2	Character 2	Character 2	Character 2	Character 2	Character 2	Character 2	Character 2	Character 2
3	Character 3	Character 3	Character 3	Character 3	Character 3	Character 3	Character 3	Character 3
4	Character 4	Character 4	Character 4	Character 4	Character 4	Character 4	Character 4	Character 4
5	Character 5	Character 5	Character 5	Character 5	Character 5	Character 5	Character 5	Character 5
6	Character 6	Character 6	Character 6	Character 6				
7	Character 7	Character 7	Character 7	Character 7				
8	Character 8	Character 8	Character 8	Character 8				
9	Character 9	Character 9	Character 9	Character 9				
A	Character 10	Character 10	Character 10	Character 10				
B	Character 11	Character 11	Character 11	Character 11				
C	Character 12	Character 12	Character 12	Character 12				
D	Character 13	Character 13	Character 13	Character 13				
E	Character 14	Character 14	Character 14	Character 14				
F	Character 15	Character 15	Character 15	Character 15				

Table 9. Recommended DC Operating Conditions

Symbol	Parameter	Minimum	Typical	Maximum	Unit	Notes
VSS	Supply Voltage	4.5	5.0	5.5	V	
REF	Reference Voltage	2.5	4.25	7	V	
I _{CC}	Normal operation	250	300	320	μA	
	Sleep mode	30	40	50	μA	
I	Voltage input in I pin	-160		80	mV	
R _{SENSE}	Sense Resistor	0.01	0.02	0.05	Ω	
V _{IH}	Logic input high	1.4		5.5	V	SDA, SCL
		0.5 × V _{CC}		V _{CC}	V	ESDA, ESCL
V _{IL}	Logic input low	-0.5		0.6		SDA, SCL
		-0.5		0.3 × V _{CC}		ESDA, ESCL
I _{Pull Down}	Pull down SDA, SCL		0.5		μA	
LED1..5	Output Drive Current		5	10	mA	
ILVOUTt	Vp output leakage		1		μA	

Characteristics of the SMBus

The SMBus functionality of the SS4002AG complies with the System Management Bus Specification version 1.10. Some critical AC/timing characteristics are shown below.

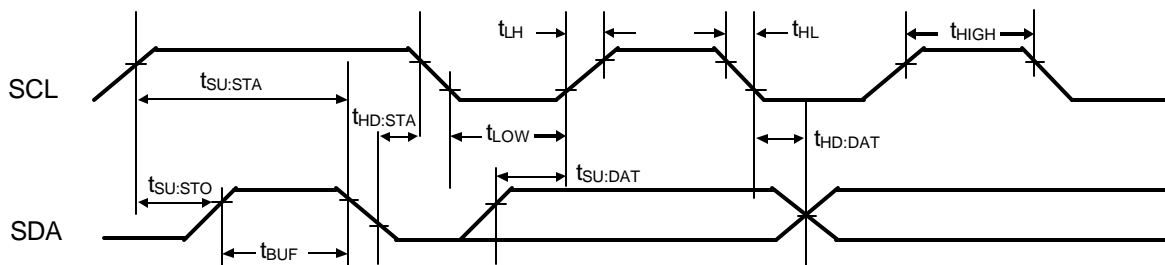
Figure 4. Timing of SMBus
Table 10. Timing parameters of the SMBus

Symbol	Description	Min	Typical	Max	Units	Notes
f _{SMB}	SMBus operation frequency	10		100	kHz	
t _{BUF}	Bus free time between stop and start conditions	4.7			μs	
t _{HD:STA}	Hold time after (repeated) start condition	4.0			μs	
t _{SU:STA}	Repeated start condition setup time	250			ns	
t _{SU:STO}	Stop condition setup time	4.0			μs	
t _{HD:DAT}	Data hold time	300			ns	
t _{SU:DAT}	Data setup time	250			ns	
t _{LOW}	Clock low period	4.7			μs	
t _{HIGH}	Clock high period	4.0			μs	
t _{HL}	Clock/Data fall time			300	ns	
t _{LH}	Clock/Data rise time			1000	ns	
t _{LOW:SEXT}	Cumulative clock low extend time (slave mode)			25	ms	see note 1
t _{LOW:MEXT}	Cumulative clock low extend time (master mode)			10	ms	see note 2

Note 1: t_{LOW:SEXT} is the cumulative time, SS4002AG, in slave mode, is allowed to extend the clock cycles in one message from the initial start to the stop.

Note 2: t_{LOW:MEXT} is the cumulative time, SS4002AG, in master mode, is allowed to extend its clock cycles within each byte of a message as defined from start-to-ack, ack-to-ack, or ack-to-stop.

APPLICATION CIRCUIT

A typical application circuit is provided in Figure 5.

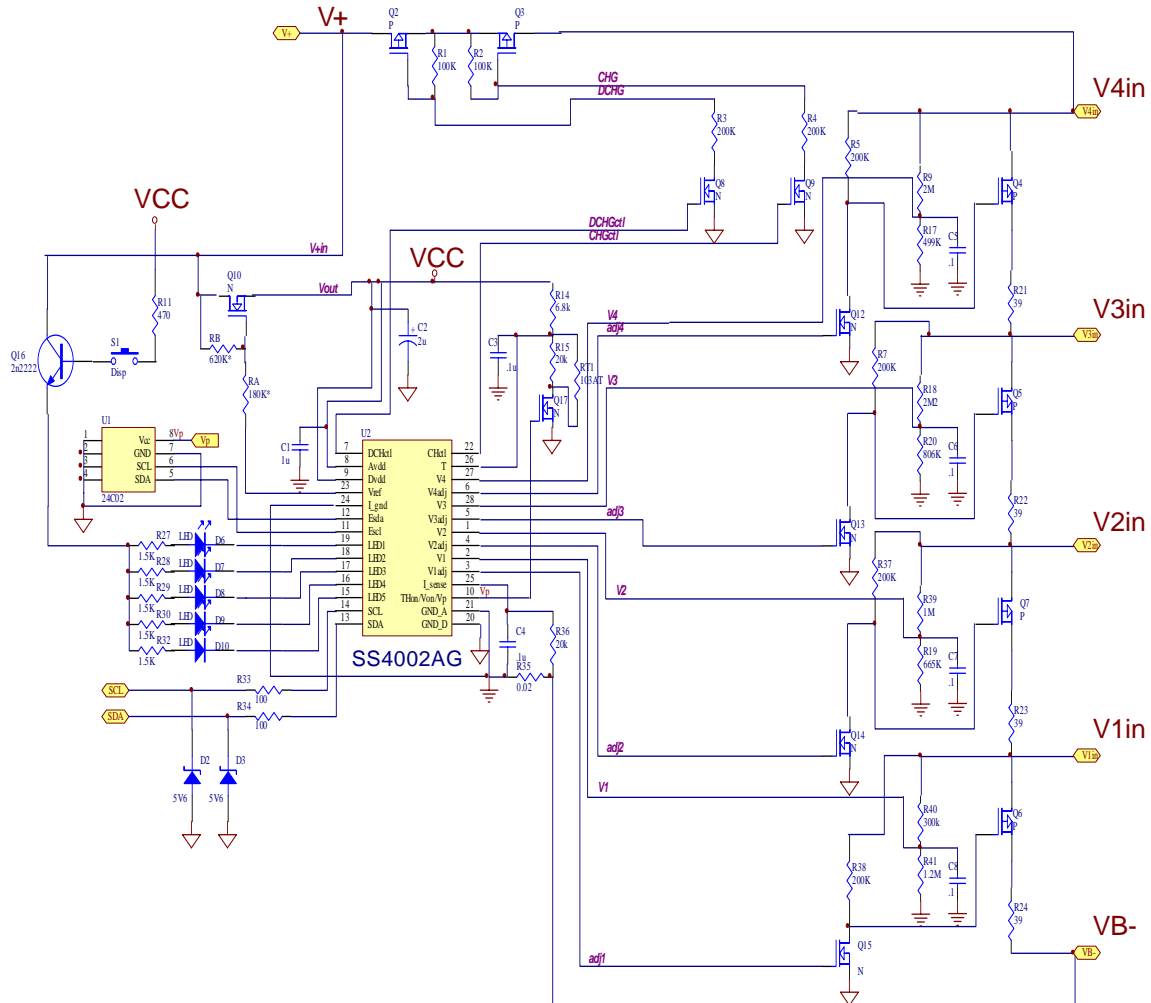
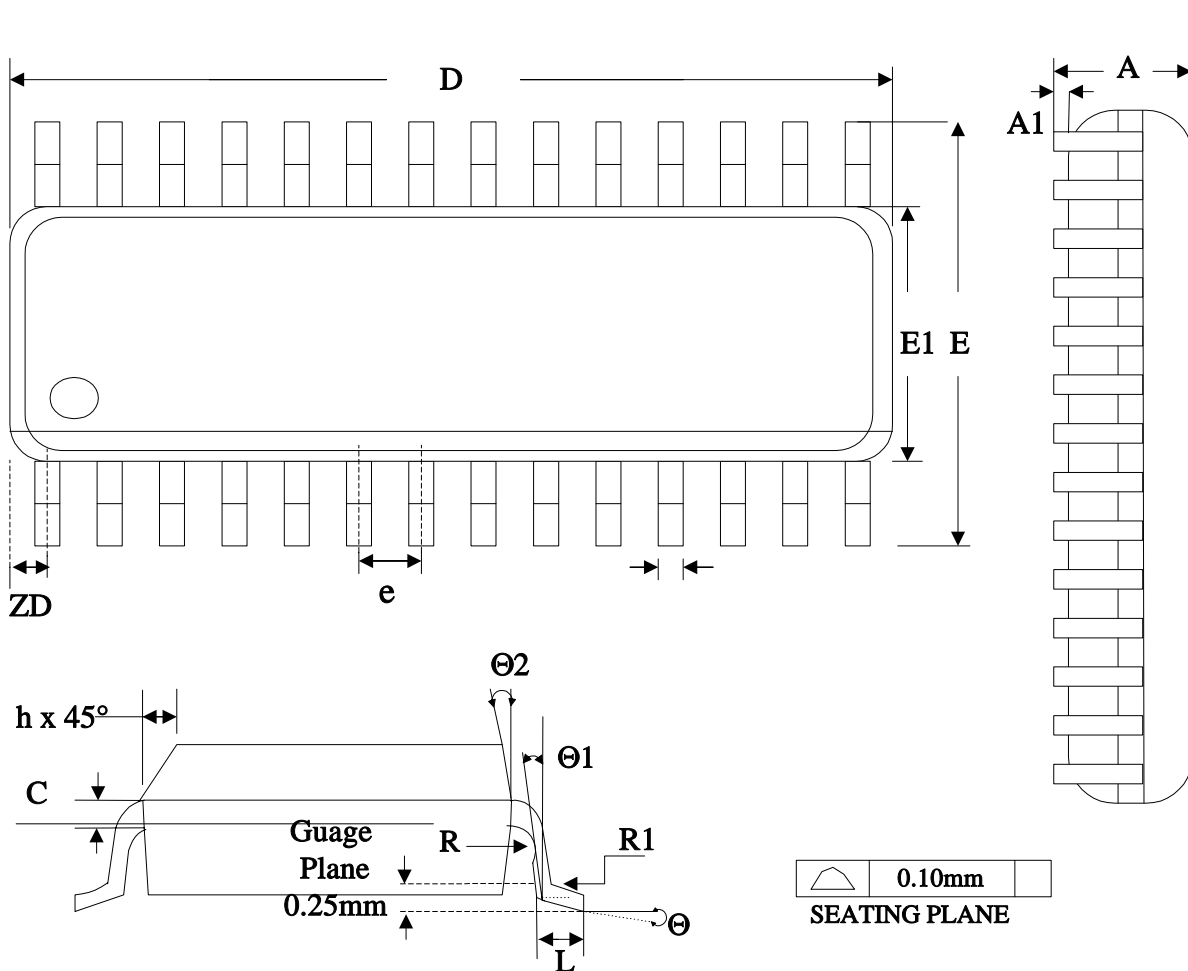

Figure 5. Typical application circuit

FET	RA	RB	Startup voltage	Regulator voltage
SSM7002	180k	620k	11.2V	8V~19V
SSM7002	160k	470k	9.9V	7.5V~16V
BSS138	160k	390k	9V	7.3V~15V

PACKAGE DIMENSIONS

28-Pin SSOP



Symbol	Dimension in mm			Dimension in inch		
	min.	nom.	max.	min.	nom.	max.
A	1.35	1.63	1.75	0.053	0.064	0.069
A1	0.10	0.15	0.25	0.004	0.006	0.010
B	0.20		0.30	0.008		0.012
C	0.18		0.25	0.007		0.010
e	0.635 basic			0.025 basic		
D	9.80	9.91	10.01	0.386	0.390	0.394
E	5.79	5.99	6.20	0.228	0.236	0.244
E1	3.81	3.91	3.99	0.150	0.154	0.157
L	0.41	0.64	1.27	0.016	0.025	0.050
h	0.25		0.50	0.010		0.020
ZD	0.838 REF.			0.033 REF.		
R1	0.20		0.33	0.008		0.013
R	0.20			0.008		
theta	0°		8°	0°		8°
theta1	0°			0°		
theta2	5°	10°	15°	5°	10°	15°
JEDEC	MO-137(AF)					

Information furnished by Silicon Standard Corporation is believed to be accurate and reliable. However, Silicon Standard Corporation makes no guarantee or warranty, express or implied, as to the reliability, accuracy, timeliness or completeness of such information and assumes no responsibility for its use, or for infringement of any patent or other intellectual property rights of third parties that may result from its use. Silicon Standard reserves the right to make changes as it deems necessary to any products described herein for any reason, including without limitation enhancement in reliability, functionality or design. No license is granted, whether expressly or by implication, in relation to the use of any products described herein or to the use of any information provided herein, under any patent or other intellectual property rights of Silicon Standard Corporation or any third parties.