

S40F ... S380F

"Slim" Profile Fast Switching Surface Mount Si-Bridge-Rectifiers Schnelle Si-Brückengleichrichter für die Oberflächenmontage mit „schlanker“ Bauhöhe

Version 2010-08-09

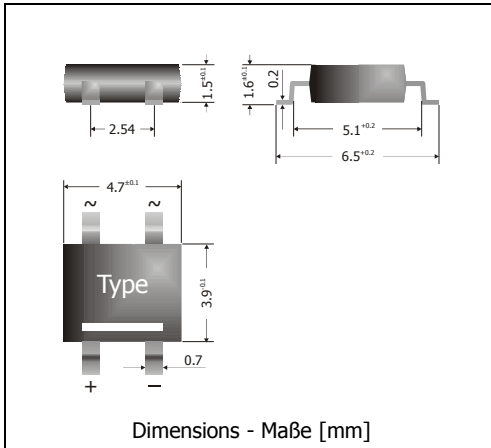

Nominal current Nennstrom	0.8 A
Alternating input voltage Eingangswchelsspannung	40...380 V
Plastic case slim profile 1.6mm ¹⁾ Kunststoffgehäuse schlanke Bauhöhe 1.6mm ¹⁾	TO-269AA MiniDIL
Weight approx. – Gewicht ca.	0.1 g
Plastic material has UL classification 94V-0 Gehäusematerial UL94V-0 klassifiziert	
Standard packaging taped and reeled Standard Lieferform gegurtet auf Rolle	

Maximum ratings

Grenzwerte

Type Typ	Max. alternating input voltage Max. Eingangswchelsspannung V_{RRM} [V]	Repetitive peak reverse voltage Periodische Spitzensperrspannung V_{RSM} [V] ²⁾
S40F	40	80
S80F	80	160
S125F	125	250
S250F	250	600
S380F	380	800

Repetitive peak forward current Periodischer Spitzenstrom	$f > 15$ Hz	I_{FRM}	10 A ³⁾
Peak forward surge current, 50/60 Hz half sine-wave Stoßstrom für eine 50/60 Hz Sinus-Halbwelle	$T_A = 25^\circ\text{C}$	I_{FSM}	40/44 A
Rating for fusing, $t < 10$ ms Grenzlastintegral, $t < 10$ ms	$T_A = 25^\circ\text{C}$	i^2t	8 A ² s
Operating junction temperature – Sperrschichttemperatur Storage temperature – Lagerungstemperatur		T_j T_s	-55...+150°C -55...+150°C

1 The "slim" profile device is introduced in 2010. During change-over phase, the former package height (2.4 instead of 1.5mm) might be supplied.

Die „schlanke“ Bauform wird 2010 eingeführt. Während der Umstellungsphase kann auch die frühere Bauhöhe (2.4 statt 1.5mm) zur Auslieferung kommen.

2 Valid per diode – Gültig pro Diode

3 Max. temperature of the terminals $T_T = 100^\circ\text{C}$ – Max. Temperatur der Anschlüsse $T_T = 100^\circ\text{C}$

Characteristics
Kennwerte

Max. average forward rectified current Dauergrenzstrom	$T_A = 50^\circ\text{C}$	R-load C-load	I_{FAV} I_{FAV}	$0.8 \text{ A}^1)$ $0.6 \text{ A}^1)$
Forward voltage Durchlass-Spannung	$T_j = 25^\circ\text{C}$	$I_F = 0.4 \text{ A}$ $I_F = 0.8 \text{ A}$	V_F	$< 1.2 \text{ V}^2)$ $< 1.3 \text{ V}^2)$
Leakage current Sperrstrom	$T_j = 25^\circ\text{C}$	$V_R = V_{RRM}$	I_R	$< 10 \mu\text{A}$
Reverse recovery time Sperrverzug	$I_F = 0.5 \text{ A}$ through/über $I_R = 1 \text{ A}$ to $I_R = 0.25 \text{ A}$		t_{rr}	$< 200 \text{ ns}$
Thermal resistance junction to ambient air Wärmewiderstand Sperrschicht – umgebende Luft			R_{thA}	$< 60 \text{ K/W}^1)$

Type Typ	Max. admissible load capacitor Max. zulässiger Ladekondensator C_L [μF]	Min. required protective resistor Min. erforderl. Schutzwiderstand R_t [Ω]
S40F	5000	0.8
S80F	2500	1.6
S125F	1500	2.5
S250F	800	5.0
S380F	600	8.5

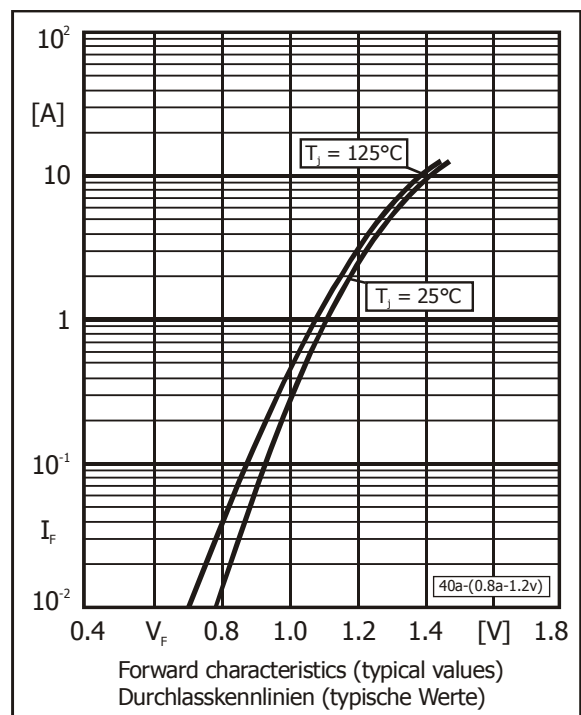
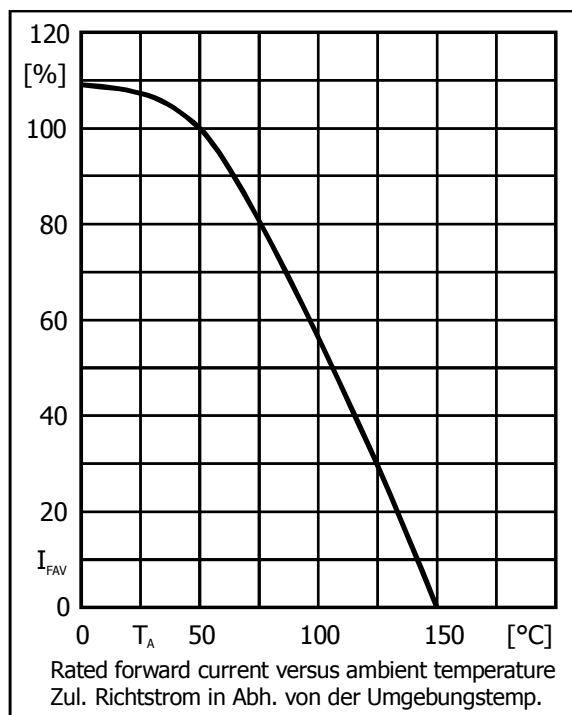

- 1 Mounted on P.C. Board with 25 mm² copper pads at each terminal
Montage auf Leiterplatte mit 25 mm² Kupferbelag (Löt-pad) an jedem Anschluss
- 2 Valid per diode – Gültig pro Diode