

# DATA SHEET

## **P80CL31; P80CL51**

Low voltage 8-bit microcontrollers  
with UART

Product specification  
Supersedes data of January 1995  
File under Integrated circuits, IC20

1997 Apr 15

# Low voltage 8-bit microcontrollers with UART

## P80CL31; P80CL51

|                 |  |      |   |
|-----------------|--|------|---|
| <b>CONTENTS</b> |  |      |   |
| 1               | FEATURES   | 13.3 | Baud rates  |
| 2               | GENERAL DESCRIPTION                                | 14   | INTERRUPT SYSTEM  |
| 2.1             | Versions: P80CL31 and P80C51                       | 14.1 | External interrupts $\overline{INT2}$ to $\overline{INT9}$                              |
| 3               | APPLICATIONS                                       | 14.2 | Interrupt priority  |
| 4               | ORDERING INFORMATION                               | 14.3 | Interrupt registers   |
| 5               | BLOCK DIAGRAM                                      | 15   | OSCILLATOR CIRCUITRY  |
| 6               | FUNCTIONAL DIAGRAM                                 | 16   | RESET   |
| 7               | PINNING INFORMATION                                | 16.1 | External reset using the RST pin  |
| 7.1             | Pinning  | 16.2 | Power-on-reset  |
| 7.2             | Pin description                                    | 17   | MASK OPTIONS FOR P80CL31 AND P80C51   |
| 8               | FUNCTIONAL DESCRIPTION OVERVIEW                    | 17.1 | P80CL31: ROMless version  |
| 8.1             | General  | 17.2 | P80C51: 5V standard version   |
| 8.2             | CPU timing   | 18   | SPECIAL FUNCTION REGISTERS<br>OVERVIEW  |
| 9               | MEMORY ORGANIZATION                                | 19   | INSTRUCTION SET   |
| 9.1             | Program Memory                                     | 20   | LIMITING VALUES   |
| 9.2             | Data Memory  | 21   | DC CHARACTERISTICS FOR P80CL31 AND<br>P80CL51   |
| 9.3             | Special Function Registers (SFRs)                  | 22   | DC CHARACTERISTICS FOR P80C51   |
| 9.4             | Addressing   | 23   | AC CHARACTERISTICS  |
| 10              | I/O FACILITIES                                     | 24   | P85CL000HFZ 'PIGGY-BACK'<br>SPECIFICATION   |
| 10.1            | Ports  | 24.1 | General description   |
| 10.2            | Port options                                       | 24.2 | Feature differences/additional features with<br>respect to P80CL51                      |
| 10.3            | Port 0 options                                     | 24.3 | Common specification/feature differences<br>between P85CL000HFZ and<br>P83CL410/P80CL51 |
| 10.4            | SET/RESET options                                  | 25   | PACKAGE OUTLINES  |
| 11              | TIMERS/EVENT COUNTERS                              | 26   | SOLDERING   |
| 12              | REDUCED POWER MODES                                | 26.1 | Introduction  |
| 12.1            | Idle mode  | 26.2 | DIP   |
| 12.2            | Power-down mode                                    | 26.3 | QFP and VSO   |
| 12.3            | Wake-up from Power-down mode                       | 27   | DEFINITIONS   |
| 12.4            | Power Control Register (PCON)                      | 28   | LIFE SUPPORT APPLICATIONS   |
| 12.5            | Status of external pins                            |      |   |
| 13              | STANDARD SERIAL INTERFACE SIO0:<br>UART            |      |   |
| 13.1            | Multiprocessor communications                      |      |   |
| 13.2            | Serial Port Control and Status Register<br>(S0CON) |      |   |

# Low voltage 8-bit microcontrollers with UART

## P80CL31; P80CL51

### 1 FEATURES

- Full static 80C51 Central Processing Unit
- 8-bit CPU, ROM, RAM, I/O in a 40-lead DIP, 40-lead VSO or 44-lead QFP package
- 128 bytes on-chip RAM Data Memory
- 4 kbytes on-chip ROM Program Memory for P80CL51
- External memory expandable up to 128 kbytes: RAM up to 64 kbytes and ROM up to 64 kbytes
- Four 8-bit ports; 32 I/O lines
- Two 16-bit Timer/Event counters
- On-chip oscillator suitable for RC, LC, quartz crystal or ceramic resonator
- Thirteen source, thirteen vector, nested interrupt structure with two priority levels
- Full duplex serial port (UART)
- Enhanced architecture with:
  - non-page oriented instructions
  - direct addressing
  - four 8-byte RAM register banks
  - stack depth limited only by available internal RAM (maximum 128 bytes)
  - multiply, divide, subtract and compare instructions
- Reduced power consumption through Power-down and Idle modes
- Wake-up via external interrupts at Port 1
- Frequency range: 0 to 16 MHz (P80C51: 3.5 MHz min.)
- Supply voltage: 1.8 to 6.0 V (P80C51: 5.0 V  $\pm$ 10%)
- Very low current consumption
- Operating ambient temperature range:  $-40$  to  $+85$  °C.

### 2 GENERAL DESCRIPTION

The P80CL31; P80CL51 (hereafter generally referred to as the P80CLx1) is manufactured in an advanced CMOS technology. The P80CLx1 has the same instruction set as the 80C51, consisting of over 100 instructions: 49 one-byte, 46 two-byte, and 16 three-byte. The device operates over a wide range of supply voltages and has low power consumption; there are two software selectable modes for power reduction: Idle and Power-down. For emulation purposes, the P85CL000 (piggy-back version) with 256 bytes of RAM is recommended.

This data sheet details the specific properties of the P80CL31; P80CL51. For details of the 80C51 core see "*Data Handbook IC20*".

#### 2.1 Versions: P80CL31 and P80C51

The P80CL31 is the ROMless version of the P80CL51. The mask options on the P80CL31 are fixed as follows:

- All ports have option '1S' (standard, HIGH after reset)
- Oscillator option: Oscillator 3
- Power-on-reset option: OFF.

The P80C51 is a restricted-voltage range version of the P80CL51. The operating voltage is 5.0 V  $\pm$ 10%.

### 3 APPLICATIONS

The P80CLx1 is especially suited for real-time applications such as instrumentation, industrial control, intelligent computer peripherals and consumer products. The P80CLx1 also functions as an arithmetic processor having facilities for both binary and BCD arithmetic plus bit-handling capabilities.

# Low voltage 8-bit microcontrollers with UART

## P80CL31; P80CL51

### 4 ORDERING INFORMATION

| TYPE NUMBER <sup>(1)</sup> |            | PACKAGE |   |          |
|----------------------------|------------|---------|---|----------|
| ROMless                    | ROM        | NAME    | DESCRIPTION   | VERSION  |
| P80CL31HFP                 | P80CL51HFP | DIP40   | plastic dual in-line package; 40 leads (600 mil)                                    | SOT129-1 |
| P80CL31HFT                 | P80CL51HFT | VSO40   | plastic very small outline package; 40 leads  | SOT158-1 |
| P80CL31HFH                 | P80CL51HFH | QFP44   | plastic quad flat package; 44 leads (lead length 1.3 mm);<br>body 10 × 10 × 1.75 mm | SOT307-2 |
| –                          | P80C51HFP  | DIP40   | plastic dual in-line package; 40 leads (600 mil)                                    | SOT129-1 |
| –                          | P80C51HFT  | VSO40   | plastic very small outline package; 40 leads  | SOT158-1 |
| –                          | P80C51HFH  | QFP44   | plastic quad flat package; 44 leads (lead length 1.3 mm);<br>body 10 × 10 × 1.75 mm | SOT307-2 |

#### Note

1. Refer to the Order Entry Form (OEF) for this device for the full type number, including options/program.

# Low voltage 8-bit microcontrollers with UART

## P80CL31; P80CL51

### 5 BLOCK DIAGRAM

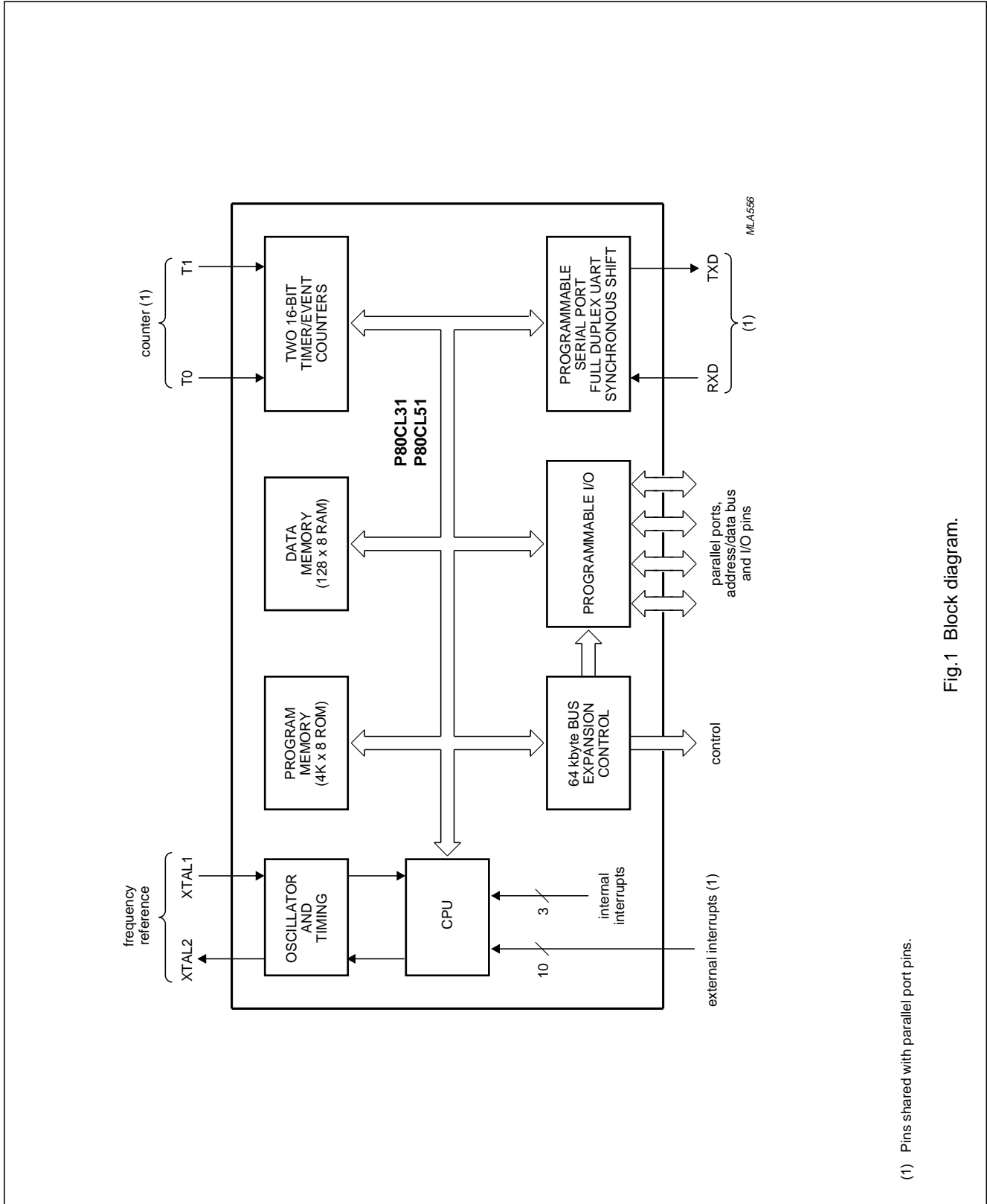

Fig.1 Block diagram.

(1) Pins shared with parallel port pins.

Low voltage 8-bit microcontrollers with UART

P80CL31; P80CL51

6 FUNCTIONAL DIAGRAM

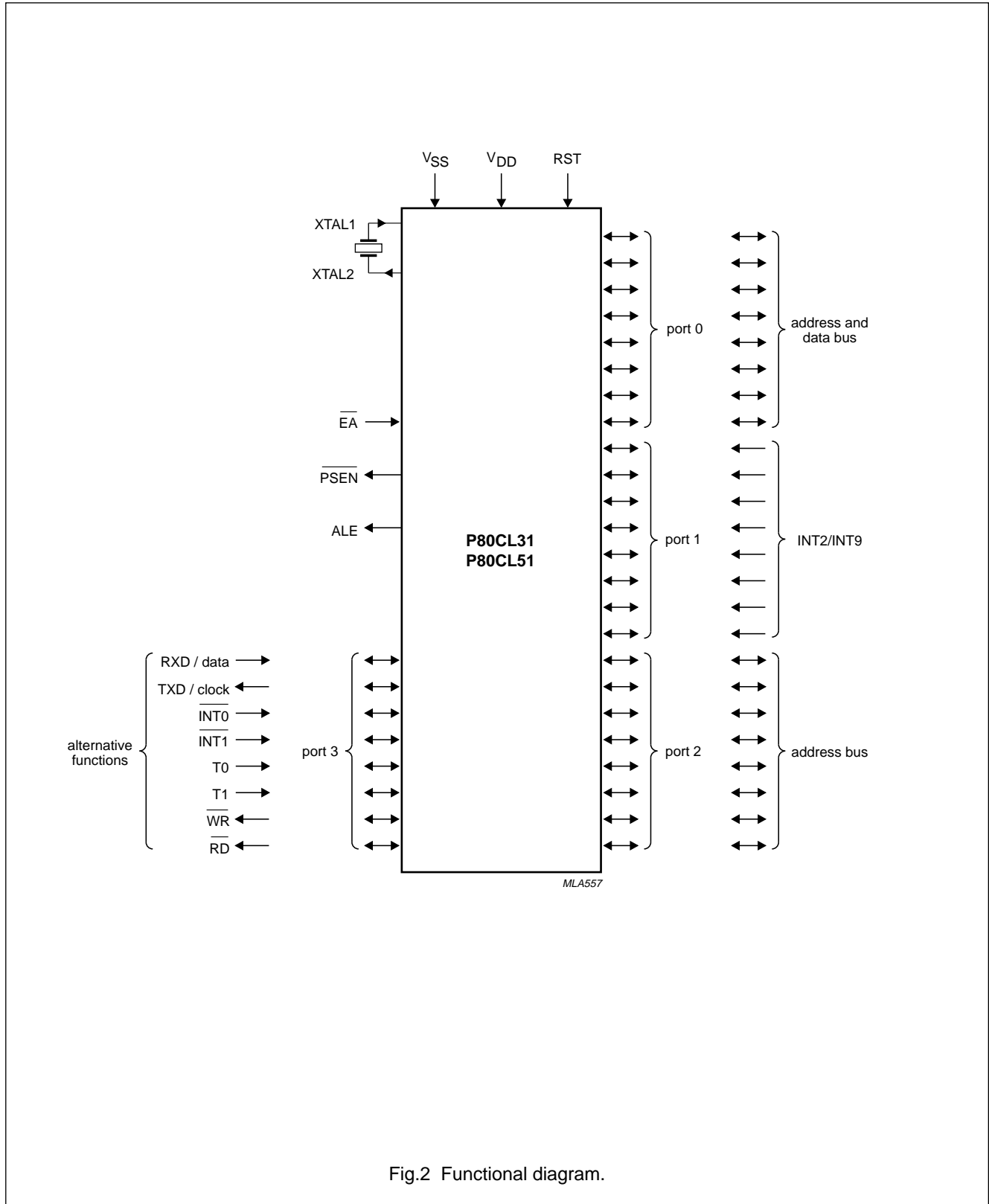

Fig.2 Functional diagram.

# Low voltage 8-bit microcontrollers with UART

## P80CL31; P80CL51

### 7 PINNING INFORMATION

#### 7.1 Pinning

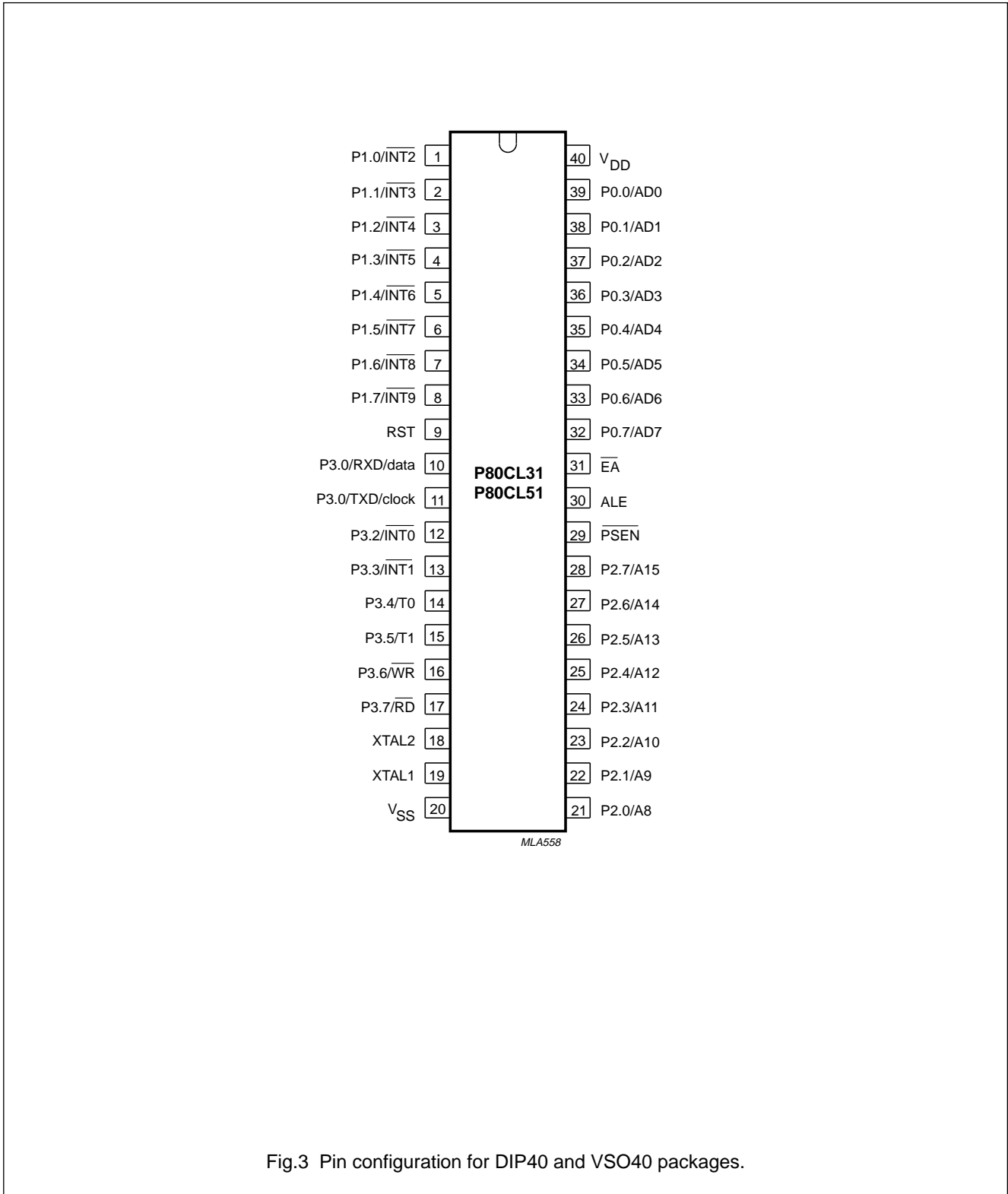

Fig.3 Pin configuration for DIP40 and VSO40 packages.

Low voltage 8-bit microcontrollers with  
UART

P80CL31; P80CL51

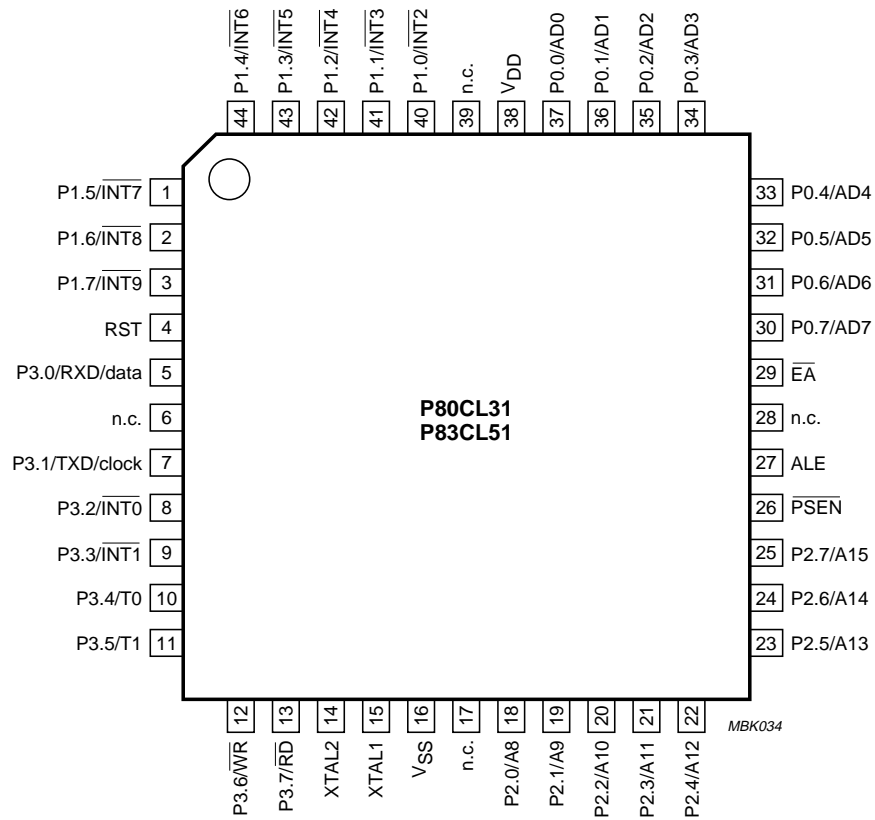

Fig.4 Pin configuration for QFP44 package.



# Low voltage 8-bit microcontrollers with UART

## P80CL31; P80CL51

### 7.2 Pin description

**Table 1** Pin description for DIP40 (SOT190-1), VSO40 (SOT319-2) and QFP44 (SOT307-2) packages

For more extensive description of the port pins see Chapter 10 "I/O facilities".

| SYMBOL   | PIN  |   | DESCRIPTION  |
|--|--|---|--|
|  | DIP40<br>VSO40                               | QFP44                                     |  |
| P1.0/ $\overline{\text{INT2}}$<br>P1.1/ $\overline{\text{INT3}}$<br>P1.2/ $\overline{\text{INT4}}$<br>P1.3/ $\overline{\text{INT5}}$<br>P1.4/ $\overline{\text{INT6}}$<br>P1.5/ $\overline{\text{INT7}}$<br>P1.6/ $\overline{\text{INT8}}$<br>P1.7/ $\overline{\text{INT9}}$ | 1<br>2<br>3<br>4<br>5<br>6<br>7<br>8         | 40<br>41<br>42<br>43<br>44<br>1<br>2<br>3 | <ul style="list-style-type: none"> <li>• <b>Port 1:</b> 8-bit bidirectional I/O port (P1.0 to P1.7). Port pins that have logic 1s written to them are pulled HIGH by internal pull-ups, and in this state can be used as inputs. As inputs, Port 1 pins that are externally pulled LOW will source current (<math>I_{IL}</math>, see Chapter 21) due to the internal pull-ups. Port 1 output buffers can sink/source 4 LS TTL loads.</li> <li>• <b>Alternative functions:</b> <ul style="list-style-type: none"> <li>– <math>\overline{\text{INT2}}</math> to <math>\overline{\text{INT9}}</math> are external interrupt inputs.</li> </ul> </li> </ul>  |
| RST  | 9  | 4   | <b>Reset:</b> a HIGH level on this pin for two machine cycles while the oscillator is running resets the device.   |
| P3.0/RXD/data<br>P3.1/TXD/clock<br>P3.2/ $\overline{\text{INT0}}$<br>P3.3/ $\overline{\text{INT1}}$<br>P3.4/T0<br>P3.5/T1<br>P3.6/ $\overline{\text{WR}}$<br>P3.7/ $\overline{\text{RD}}$  | 10<br>11<br>12<br>13<br>14<br>15<br>16<br>17 | 5<br>7<br>8<br>9<br>10<br>11<br>12<br>13  | <ul style="list-style-type: none"> <li>• <b>Port 3:</b> 8-bit bidirectional I/O port (P3.0 to P3.7). Same characteristics as Port 1.</li> <li>• <b>Alternative functions:</b> <ul style="list-style-type: none"> <li>– RXD/data is the serial port receiver data input (asynchronous) or data input/output (synchronous)</li> <li>– TXD/clock is the serial port receiver data output (asynchronous) or clock output (synchronous)</li> <li>– <math>\overline{\text{INT0}}</math> and <math>\overline{\text{INT1}}</math> are external interrupts 0 and 1</li> <li>– T0 and T1 are external inputs for timers 0 and 1</li> <li>– <math>\overline{\text{WR}}</math> is the external Data Memory write strobe</li> <li>– <math>\overline{\text{RD}}</math> is the external Data Memory read strobe.</li> </ul> </li> </ul> |
| XTAL2  | 18   | 14  | <b>Crystal oscillator output:</b> output of the inverting amplifier of the oscillator. Left open when external clock is used.  |
| XTAL1  | 19   | 15  | <b>Crystal oscillator input:</b> input to the inverting amplifier of the oscillator, also the input for an externally generated clock source.  |
| V <sub>SS</sub>  | 20   | 16  | Ground: circuit ground potential.  |
| P2.0 to P2.7<br>A8 to A15  | 21 to 28                                     | 18 to 25                                  | <ul style="list-style-type: none"> <li>• <b>Port 2:</b> 8-bit bidirectional I/O port (P2.0 to P2.7) with internal pull-ups. Same characteristics as Port 1.</li> <li>• <b>High-order addressing:</b> Port 2 emits the high-order address byte (A8 to A15) during accesses to external memory that use 16-bit addresses (MOVX @DPTR). In this application it uses the strong internal pull-ups when emitting logic 1s. During accesses to external memory that use 8-bit addresses (MOVX @Ri), Port 2 emits the contents of the P2 Special Function Register.</li> </ul>  |
| $\overline{\text{PSEN}}$   | 29   | 26  | <b>Program Store Enable.</b> Output read strobe to external Program Memory. When executing code out of external Program Memory, PSEN is activated twice each machine cycle. However, during each access to external Data Memory two PSEN activations are skipped.  |

## Low voltage 8-bit microcontrollers with UART

P80CL31; P80CL51

| SYMBOL                     | PIN            |                  | DESCRIPTION  |
|----------------------------|----------------|------------------|--|
|                            | DIP40<br>VSO40 | QFP44            |  |
| ALE                        | 30             | 27               | <b>Address Latch Enable.</b> Output pulse for latching the low byte of the address during access to external memory. ALE is emitted at a constant rate of $\frac{1}{6} \times f_{osc}$ , and may be used for external timing or clocking purposes (assuming MOVX instructions are not used).   |
| $\overline{EA}$            | 31             | 29               | <b>External Access.</b> When $\overline{EA}$ is held HIGH the CPU executes out of internal program memory (unless the program counter exceeds 0FFFH). Holding $\overline{EA}$ LOW forces the CPU to execute out of external memory regardless of the value of the program counter.   |
| P0.7 to P0.0<br>AD7 to AD0 | 32 to 39       | 30 to 37         | <ul style="list-style-type: none"> <li>• <b>Port 0:</b> 8-bit open-drain bidirectional I/O port. As an open-drain output port it can sink 8 LS TTL loads. Port 0 pins that have logic 1s written to them float, and in that state will function as high impedance inputs.</li> <li>• <b>Low-order addressing:</b> Port 0 is also the multiplexed low-order address and data bus during access to external memory. The strong internal pull-ups are used while emitting logic 1s within the low order address.</li> </ul> |
| V <sub>DD</sub>            | 40             | 38               | Power supply.  |
| n.c.                       | –              | 6, 17, 28,<br>39 | Not connected.   |

## Low voltage 8-bit microcontrollers with UART

## P80CL31; P80CL51

### 8 FUNCTIONAL DESCRIPTION OVERVIEW

This chapter gives a brief overview of the device. The detailed functional description is in the following chapters as follows:

- Chapter 9 "Memory organization"
- Chapter 10 "I/O facilities"
- Chapter 11 "Timers/event counters"
- Chapter 12 "Reduced power modes"
- Chapter 13 "Standard serial interface SIO0: UART"
- Chapter 14 "Interrupt system"
- Chapter 15 "Oscillator circuitry"
- Chapter 16 "Reset".

#### 8.1 General

The P80CLx1 is a stand-alone high-performance CMOS microcontroller designed for use in real-time applications such as instrumentation, industrial control, intelligent computer peripherals and consumer products.

The device provides hardware features, architectural enhancements and new instructions to function as a controller for applications requiring up to 64 kbytes of Program Memory and/or up to 64 kbytes of Data Memory.

The P80CLx1 contains 4 kbytes Program Memory (ROM; P80CL51 only); a static 128 bytes Data Memory (RAM); 32 I/O lines; two 16-bit timer/event counters; a thirteen-source, two priority-level, nested interrupt structure and on-chip oscillator and timing circuit. A standard UART serial interface is also provided.

The device has two software-selectable modes of reduced activity for power reduction:

- **Idle mode**; freezes the CPU while allowing the timers, serial I/O and interrupt system to continue functioning.
- **Power-down mode**; saves the RAM contents but freezes the oscillator causing all other chip functions to be inoperative.

#### 8.2 CPU timing

A machine cycle consists of a sequence of 6 states. Each state lasts for two oscillator periods, thus a machine cycle takes 12 oscillator periods or 1  $\mu$ s if the oscillator frequency ( $f_{osc}$ ) is 12 MHz.

# Low voltage 8-bit microcontrollers with UART

## P80CL31; P80CL51

### 9 MEMORY ORGANIZATION

The P80CLx1 has 4 kbytes of Program Memory (ROM; P80CL51 only) plus 128 bytes of Data Memory (RAM) on board. The device has separate address spaces for Program and Data Memory (see Fig.5). Using Port latches P0 and P2, the P80CLx1 can address a maximum of 64 kbytes of program memory and a maximum of 64 kbytes of data memory. The CPU generates both read ( $\overline{RD}$ ) and write ( $\overline{WR}$ ) signals for external Data Memory accesses, and the read strobe ( $\overline{PSEN}$ ) for external Program Memory.

#### 9.1 Program Memory

The P80CL51 contains 4 kbytes of internal ROM. After reset the CPU begins execution at location 0000H. The lower 4 kbytes of Program Memory can be implemented in either on-chip ROM or external Program Memory.

If the  $\overline{EA}$  pin is tied to  $V_{DD}$ , then Program Memory fetches from addresses 0000H to 0FFFH are directed to the

internal ROM. Fetches from addresses 1000H to FFFFH are directed to external ROM. Program Counter values greater than 0FFFH are automatically addressed to external memory regardless of the state of the  $\overline{EA}$  pin.

#### 9.2 Data Memory

The P80CLx1 contains 128 bytes of internal RAM and 25 Special Function Registers (SFR). The memory map (Fig.5) shows the internal Data Memory space divided into the lower 128, the upper 128, and the SFR space. The lower 128 bytes of the internal RAM are organized as mapped in Fig.6. The lowest 32 bytes are grouped into 4 banks of 8 registers. Program instructions refer to these registers within a register bank as R0 through R7. Two bits in the Program Status Word select which register bank is in use. The next 16 bytes above the register banks form a block of bit-addressable memory space. The 128 bits in this area can be directly addressed by the single-bit manipulation instructions. The remaining registers (30H to 7FH) are directly and indirectly byte addressable.

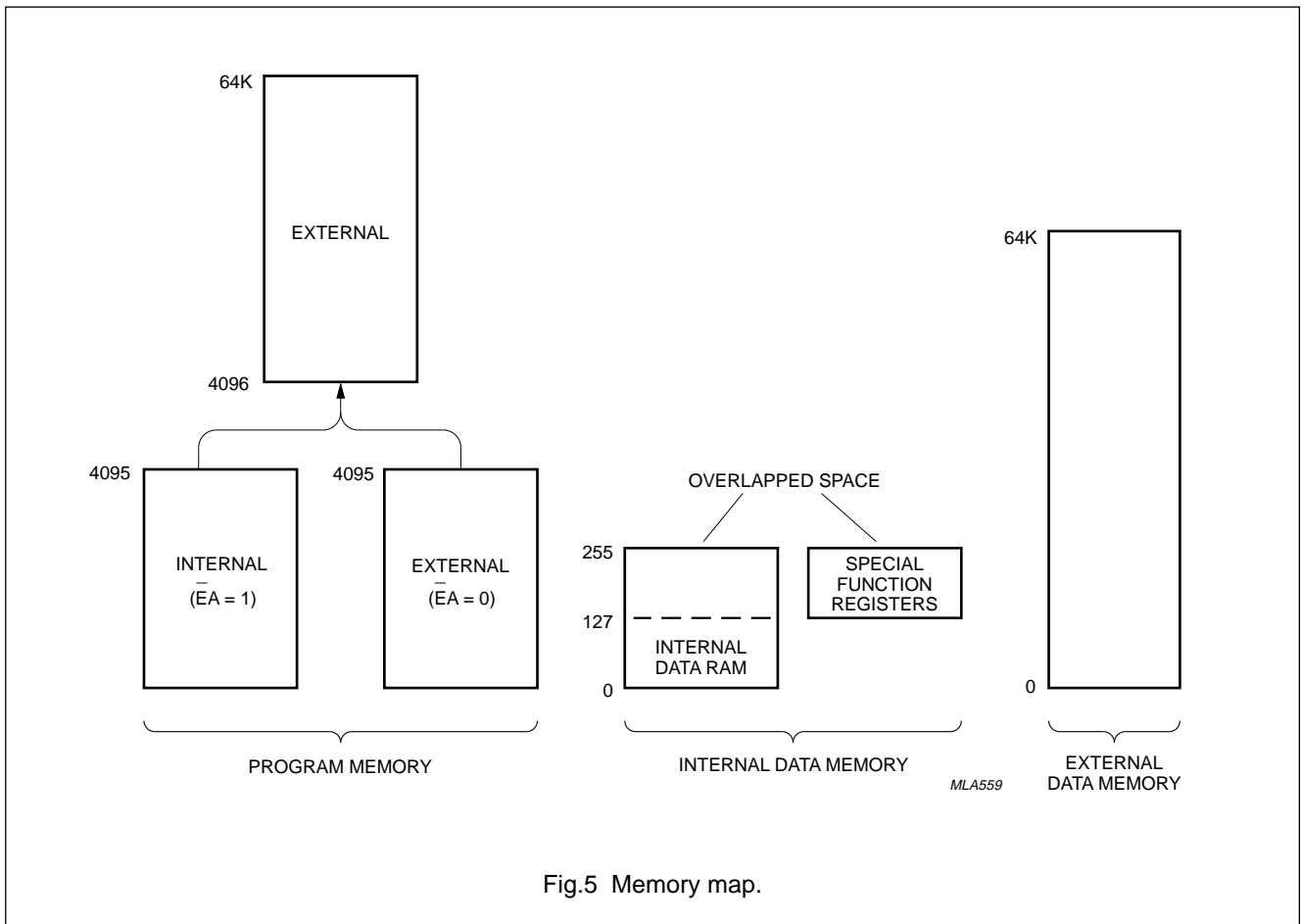

Fig.5 Memory map.

# Low voltage 8-bit microcontrollers with UART

## P80CL31; P80CL51

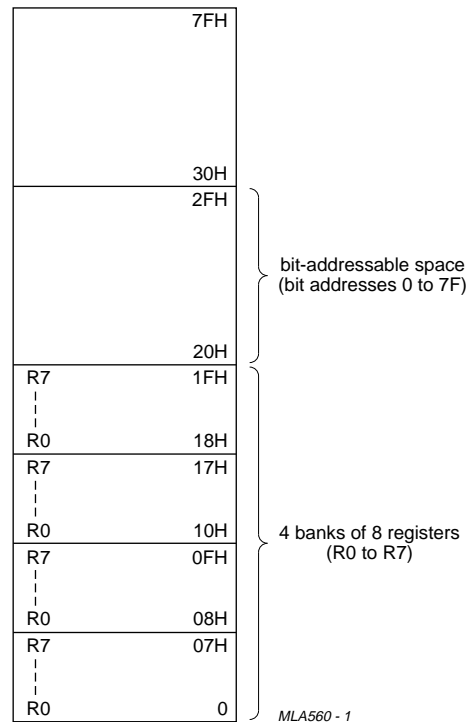

Fig.6 The lower 128 bytes of internal RAM.

### 9.3 Special Function Registers (SFRs)

The upper 128 bytes are the address locations of the SFRs. Figure 7 shows the SFR space. The SFRs include the port latches, timers, peripheral control, serial I/O registers, etc. These registers can only be accessed by direct addressing. There are 128 directly addressable locations in the SFR address space (SFRs with addresses divisible by eight).

### 9.4 Addressing

The P8xCL410 has five methods for addressing source operands:

- Register
- Direct
- Register-indirect
- Immediate
- Base-register plus index-register-indirect.

The first three methods can be used for addressing destination operands. Most instructions have a 'destination/source' field that specifies the data type, addressing methods and operands involved. For operations other than MOVs, the destination operand is also a source operand.

Access to memory addressing is as follows:

- Registers in one of the four register banks through register, direct or register-indirect
- Internal RAM (128 bytes) through direct or register-indirect
- Special Function Registers through direct
- External data memory through register-indirect
- Program Memory look-up tables through base-register plus index-register-indirect.

Low voltage 8-bit microcontrollers with  
UART

P80CL31; P80CL51

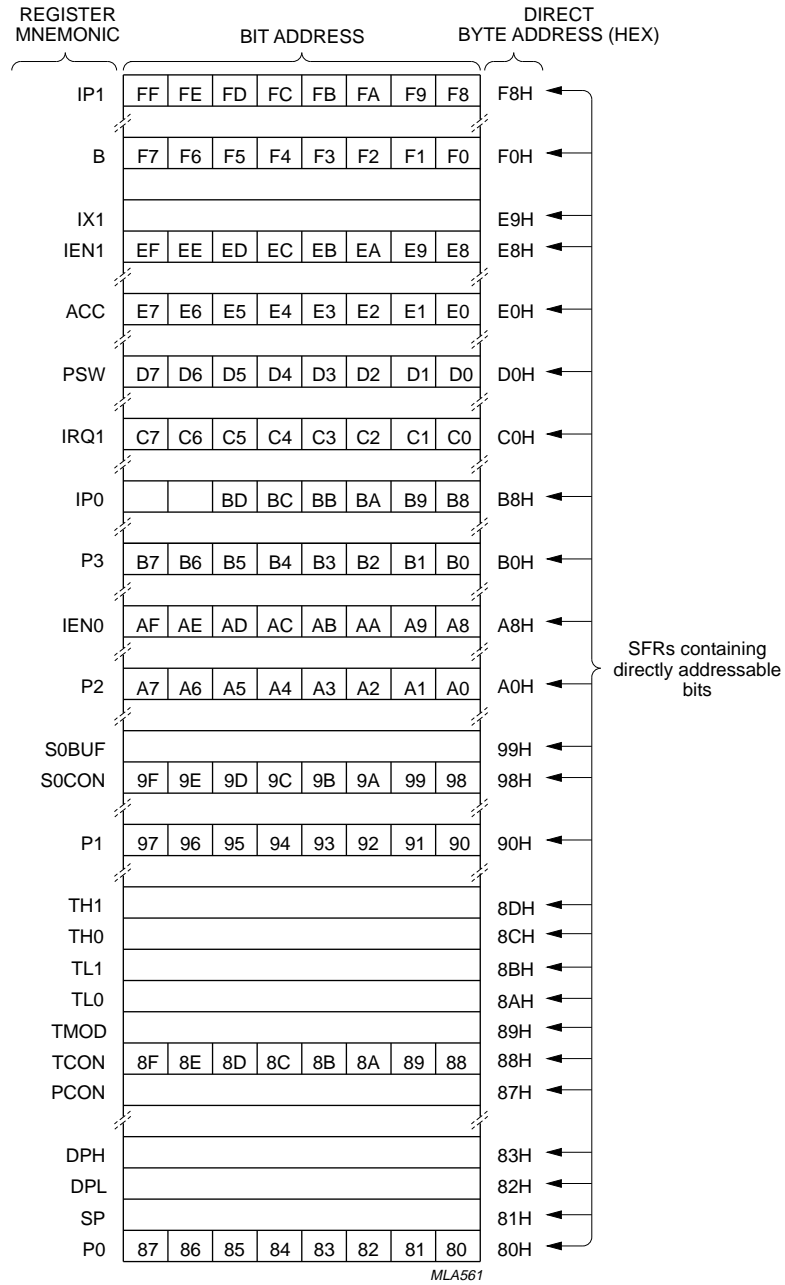

Fig.7 Special Function Register memory map.

## Low voltage 8-bit microcontrollers with UART

## P80CL31; P80CL51

### 10 I/O FACILITIES

#### 10.1 Ports

The P80CLx1 has 32 I/O lines treated as 32 individually addressable bits or as four parallel 8-bit addressable ports. Ports 0, 1, 2 and 3 perform the alternative functions detailed below. To enable a port pin alternate function, the port bit latch in its SFR must contain a logic 1.

**Port 0** Provides the multiplexed low-order address and data bus for expanding the device with standard memories and peripherals.

**Port 1** Provides the inputs for the external interrupts  $\overline{INT2}$  to  $\overline{INT9}$ .

**Port 2** Provides the high-order address when expanding the device with external Program or Data Memory.

**Port 3** Pins can be configured individually to provide:

- External interrupt request inputs:  $\overline{INT1}$  and  $\overline{INT0}$
- Timer/counter inputs: T1 and T0
- Control signals to read and write to external memories:  $\overline{RD}$  and  $\overline{WR}$
- UART input and output: RXD/data and TXD/clock.

Each port consists of a latch (SFRs P0 to P3), an output driver and input buffer. Ports 1, 2, and 3 have internal pull-ups Figure 8(a) shows that the strong transistor 'p1' is turned on for only 2 oscillator periods after a LOW-to-HIGH transition in the port latch. When on, it turns on 'p3' (a weak pull-up) through the inverter. This inverter and 'p3' form a latch which holds the logic 1. In Port 0 the pull-up 'p1' is only on when emitting logic 1s for external memory access. Writing a logic 1 to a Port 0 bit latch leaves both output transistors switched off so that the pin can be used as a high-impedance input.

#### 10.2 Port options

The pins of port 1, port 2 and port 3 may be individually configured with one of the following options. These options are also shown in Fig.8.

**Option 1 Standard Port;** quasi-bidirectional I/O with pull-up. The strong booster pull-up 'p1' is turned on for two oscillator periods after a LOW-to-HIGH transition in the port latch; Fig.8(a).

**Option 2 Open-drain;** quasi-bidirectional I/O with n-channel open-drain output. Use as an output requires the connection of an external pull-up resistor; see Fig.8(b).

**Option 3 Push-pull;** output with drive capability in both polarities. Under this option, pins can only be used as outputs; see Fig.8(c).

#### 10.3 Port 0 options

The definition of port options for Port 0 is slightly different. Two cases are considered. First, access to external memory ( $\overline{EA} = 0$  or access above the built-in memory boundary) and second, I/O accesses.

##### 10.3.1 EXTERNAL MEMORY ACCESSES

**Option 1** True logic 0 and logic 1 are written as address to the external memory (strong pull-up to be used).

**Option 2** An external pull-up resistor is required for external accesses.

**Option 3** Not allowed for external memory accesses as the port can only be used as output.

##### 10.3.2 I/O ACCESSES

**Option 1** When writing a logic 1 to the port latch, the strong pull-up 'p1' will be on for 2 oscillator periods. No weak pull-up exists. Without an external pull-up, this option can be used as a high-impedance input.

**Option 2** Open-drain; quasi-directional I/O with n-channel open-drain output. Use as an output requires the connection of an external pull-up resistor. See Fig.8(b).

**Option 3** Push-Pull; output with drive capability in both polarities. Under this option pins can only be used as outputs. See Fig.8(c).

#### 10.4 SET/RESET options

Individual mask selection of the post-reset state is available with any of the above pins. The required selection is made by appending 'S' or 'R' to Options 1, 2, or 3 above.

**Option R** RESET, at reset this pin will be initialized LOW.

**Option S** SET, at reset this pin will be initialized HIGH.

Low voltage 8-bit microcontrollers with  
UART

P80CL31; P80CL51

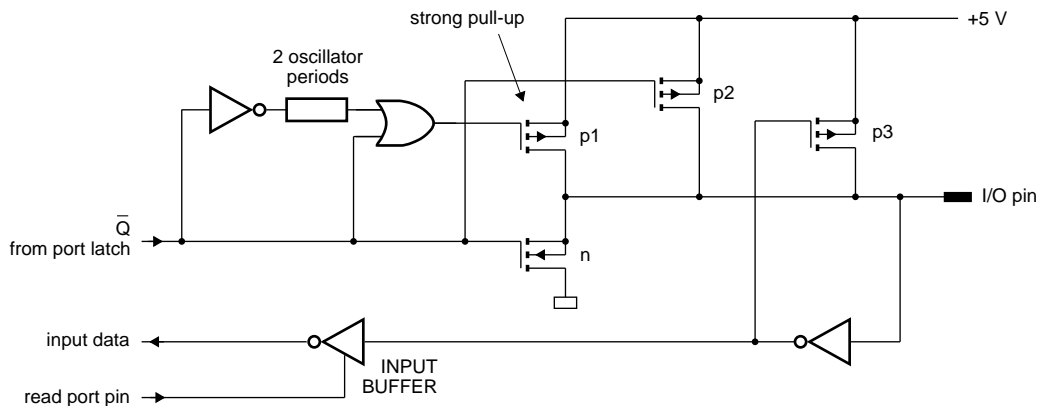

(a) Standard

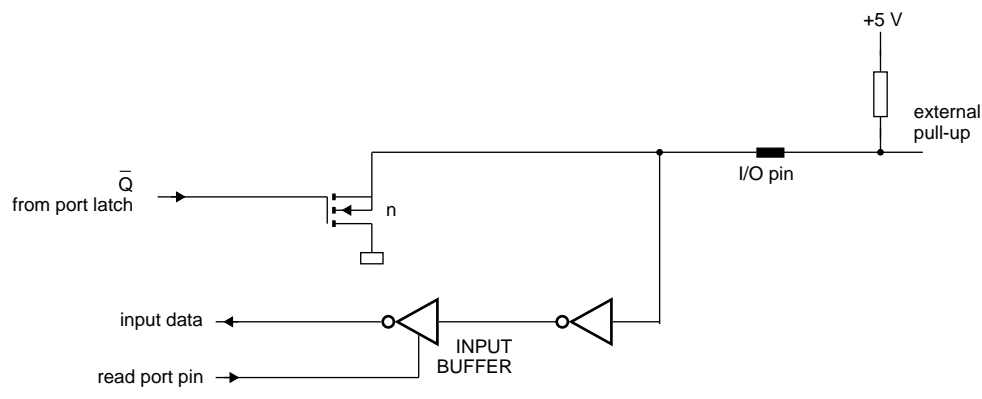

(b) Open-drain

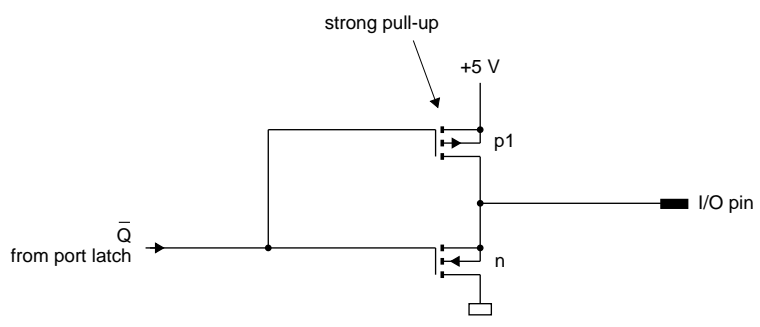

(c) Push-pull

MGD677

Fig.8 Port configuration options.



## Low voltage 8-bit microcontrollers with UART

## P80CL31; P80CL51

### 11 TIMERS/EVENT COUNTERS

The P80CLx1 contains two 16-bit timer/event counter registers; Timer 0 and Timer 1, which can perform the following functions:

- Measure time intervals and pulse durations
- Count events
- Generate interrupt requests.

In the 'Timer' operating mode the register is incremented every machine cycle. Since a machine cycle consists of 12 oscillator periods, the count rate is  $\frac{1}{12} \times f_{osc}$ .

In the 'Counter' operating mode, the register is incremented in response to a HIGH-to-LOW transition. Since it takes 2 machine cycles (24 oscillator periods) to recognize a HIGH-to-LOW transition, the maximum count rate is  $\frac{1}{24} \times f_{osc}$ . To ensure a given level is sampled, it should be held for at least one complete machine cycle.

Timer 0 and Timer 1 can be programmed independently to operate in four modes:

- Mode 0 8-bit timer or 8-bit counter each with divide-by-32 prescaler.
- Mode 1 16-bit time-interval or event counter.
- Mode 2 8-bit time-interval or event counter with automatic reload upon overflow.
- Mode 3 Timer 0 establishes TL0 and TH0 as two separate counters.

### 12 REDUCED POWER MODES

There are two software selectable modes of reduced activity for further power reduction: Idle and Power-down.

#### 12.1 Idle mode

Idle mode operation permits the external interrupts, UART, and timer blocks to continue to function while the clock to the CPU is halted.

Idle mode is entered by setting the IDL bit in the Power Control Register (PCON.0, see Table 2). The instruction that sets IDL is the last instruction executed in the normal operating mode before the Idle mode is activated.

Once in Idle mode, the CPU status is preserved along with the Stack Pointer, Program Counter, Program Status Word and Accumulator. The RAM and all other registers maintain their data during Idle mode. The status of the external pins during Idle mode is shown in Table 3.

The following functions remain active during the Idle mode:

- Timer 0 and Timer 1
- UART
- External interrupt.

These functions may generate an interrupt or reset; thus ending the Idle mode.

There are two ways to terminate the Idle mode:

1. Activation of any enabled interrupt will cause IDL (PCON.0) to be cleared by hardware thus terminating the Idle mode. The interrupt is serviced, and following the RETI instruction, the next instruction to be executed will be the one following the instruction that put the device in the Idle mode. The flag bits GF0 (PCON.2) and GF1 (PCON.3) may be used to determine whether the interrupt was received during normal execution or during the Idle mode. For example, the instruction that writes to PCON.0 can also set or clear one or both flag bits. When the Idle mode is terminated by an interrupt, the service routine can examine the status of the flag bits.
2. The second way of terminating the Idle mode is with an external hardware reset. Since the oscillator is still running, the hardware reset is required to be active for two machine cycles (24 oscillator periods) to complete the reset operation. Reset redefines all SFRs but does not affect the on-chip RAM.

#### 12.2 Power-down mode

Operation in Power-down mode freezes the oscillator. The internal connections which link both Idle and Power-down signals to the clock generation circuit are shown in Fig.9.

Power-down mode is entered by setting the PD bit in the Power Control Register (PCON.1, see Table 2). The instruction that sets PD is the last executed prior to going into the Power-down mode.

Once in the Power-down mode, the oscillator is stopped. The contents of the on-chip RAM and the SFRs are preserved. The port pins output the value held by their respective SFRs. ALE and PSEN are held LOW.

In the Power-down mode,  $V_{DD}$  may be reduced to minimize circuit power consumption. The supply voltage must not be reduced until the Power-down mode is entered, and must be restored before the hardware reset is applied which will free the oscillator. Reset should not be released until the oscillator has restarted and stabilized.

## Low voltage 8-bit microcontrollers with UART

P80CL31; P80CL51

### 12.3 Wake-up from Power-down mode

When in Power-down mode the controller can be woken-up with either the external interrupts  $\overline{\text{INT2}}$  to  $\overline{\text{INT9}}$ , or a reset operation. The wake-up operation has two basic approaches as explained in Section 12.3.1; 12.3.2 and illustrated in Fig.10.

#### 12.3.1 WAKE-UP USING $\overline{\text{INT2}}$ TO $\overline{\text{INT9}}$

If any of the interrupts  $\overline{\text{INT2}}$  to  $\overline{\text{INT9}}$  are enabled, the device can be woken-up from the Power-down mode with the external interrupts. To ensure that the oscillator is stable before the controller restarts, the internal clock will remain inactive for 1536 oscillator periods. This is controlled by an on-chip delay counter.

#### 12.3.2 WAKE-UP USING RST

To wake-up the P80CLx1, the RST pin must be kept HIGH for a minimum of 24 periods. The on-chip delay counter is inactive. The user must ensure that the oscillator is stable before any operation is attempted.

### 12.4 Power Control Register (PCON)

See Tables 2 and 3. Idle and Power-down modes are activated by software using this SFR. PCON is not bit-addressable.

### 12.5 Status of external pins

The status of the external pins during Idle and Power-down mode is shown in Table 4. If the Power-down mode is activated whilst accessing external Program Memory, the port data that is held in the Special Function Register P2 is restored to Port 2.

If the data is a logic 1, the port pin is held HIGH during the Power-down mode by the strong pull-up transistor 'p1'; see Fig.8(a).

**Table 2** Power Control Register (address 87H)

| 7    | 6 | 5 | 4 | 3   | 2   | 1  | 0   |
|------|---|---|---|-----|-----|----|-----|
| SMOD | – | – | – | GF1 | GF0 | PD | IDL |

**Table 3** Description of PCON bits

| BIT     | SYMBOL      | DESCRIPTION  |
|---------|-------------|--|
| 7       | SMOD        | <b>Double Baud rate bit</b> ; see description of UART                  |
| 6, 5, 4 | –           | reserved   |
| 3 and 2 | GF1 and GF0 | <b>General purpose flag bits</b>                                       |
| 1       | PD          | <b>Power-down bit</b> ; setting this bit activates the Power-down mode |
| 0       | IDL         | <b>Idle mode bit</b> ; setting this bit activates the Idle mode        |

**Table 4** Status of external pins during Idle and Power-down modes

| MODE       | MEMORY   | ALE | $\overline{\text{PSEN}}$ | PORT 0    | PORT 1    | PORT 2    | PORT 3    | PORT 4    |
|------------|----------|-----|--------------------------|-----------|-----------|-----------|-----------|-----------|
| Idle       | internal | 1   | 1                        | port data | port data | port data | port data | port data |
|            | external | 1   | 1                        | floating  | port data | address   | port data | port data |
| Power-down | internal | 0   | 0                        | port data | port data | port data | port data | port data |
|            | external | 0   | 0                        | floating  | port data | port data | port data | port data |

Low voltage 8-bit microcontrollers with  
UART

P80CL31; P80CL51

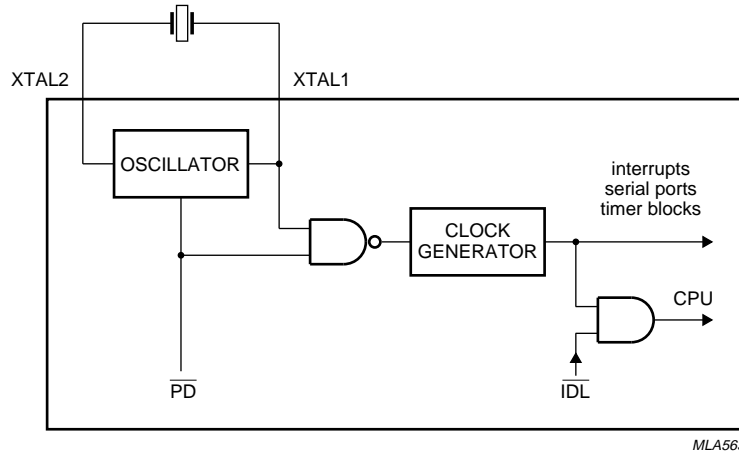

Fig.9 Internal clock control in Idle and Power-down mode.

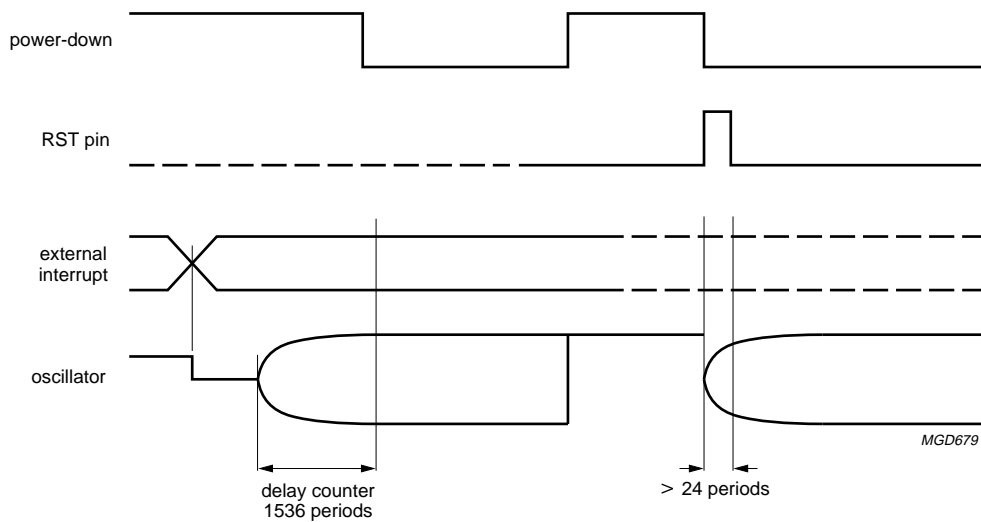

Fig.10 Wake-up operation.

## Low voltage 8-bit microcontrollers with UART

## P80CL31; P80CL51

### 13 STANDARD SERIAL INTERFACE SIO0: UART

This serial port is full duplex which means that it can transmit and receive simultaneously. It is also receive-buffered and can commence reception of a second byte before a previously received byte has been read from the register. (However, if the first byte has not been read by the time the reception of the second byte is complete, one of the bytes will be lost). The serial port receive and transmit registers are both accessed via the Special Function Register S0BUF. Writing to S0BUF loads the transmit register and reading S0BUF accesses a physically separate receive register.

The serial port can operate in 4 modes:

- Mode 0 Serial data enters and exits through RXD. TXD outputs the shift clock. Eight bits are transmitted/received (LSB first). The baud rate is fixed at  $\frac{1}{12} \times f_{osc}$ .
- Mode 1 10 bits are transmitted (through TXD) or received (through RXD): a start bit (logic 0), 8 data bits (LSB first), and a stop bit (logic 1). On receive, the stop bit goes into RB8 in Special Function Register S0CON. The baud rate is variable.
- Mode 2 11 bits are transmitted (through TXD) or received (through RXD): start bit (logic 0), 8 data bits (LSB first), a programmable 9<sup>th</sup> data bit, and a stop bit (logic 1). On transmit, the 9<sup>th</sup> data bit (TB8 in S0CON) can be assigned the value of a logic 0 or logic 1. Or, for example, the parity bit (P, in the PSW) could be moved into TB8. On receive, the 9<sup>th</sup> data bit goes into RB8 in S0CON, while the stop bit is ignored. The baud rate is programmable to either  $\frac{1}{32}$  or  $\frac{1}{64} \times f_{osc}$ .
- Mode 3 11 bits are transmitted (through TXD) or received (through RXD): a start bit (logic 0), 8 data bits (LSB first), a programmable 9<sup>th</sup> data bit and a stop bit (logic 1). In fact, Mode 3 is the same as Mode 2 in all respects except baud rate. The baud rate in Mode 3 is variable.

In all four modes, transmission is initiated by any instruction that uses S0BUF as a destination register. Reception is initiated in Mode 0 by the condition RI = 0 and REN = 1. Reception is initiated in the other modes by the incoming start bit if REN = 1.

#### 13.1 Multiprocessor communications

Modes 2 and 3 have a special provision for multiprocessor communications. In these modes, 9 data bits are received. The 9<sup>th</sup> bit goes into RB8. The following bit is the stop bit. The port can be programmed such that when the stop bit is received, the serial port interrupt will be activated, but only if RB8 = 1. This feature is enabled by setting bit SM2 in S0CON. One use of this feature, in multiprocessor systems, is as follows.

When the master processor wants to transmit a block of data to one of several slaves, it first sends out an address byte which identifies the target slave. An address byte differs from a data byte in that the 9<sup>th</sup> bit is HIGH in an address byte and LOW in a data byte. With SM2 = 1, no slave will be interrupted by a data byte. An address byte, however, will interrupt all slaves, so that each slave can examine the received byte and see if it is being addressed. The addressed slave will clear its SM2 bit and prepare to receive the data bytes that will be sent. The slaves that were not being addressed leave their SM2 bits set and go on about their business, ignoring the coming data bytes.

SM2 has no effect in Mode 0, and in Mode 1 can be used to check the validity of the stop bit. In a Mode 1 reception, if SM2 = 1, the receive interrupt will not be activated unless a valid stop bit is received.

#### 13.2 Serial Port Control and Status Register (S0CON)

The Serial Port Control and Status Register is the Special Function Register S0CON. The register contains not only the mode selection bits, but also the 9<sup>th</sup> data bit for transmit and receive (TB8 and RB8), and the serial port interrupt bits (TI and RI).

# Low voltage 8-bit microcontrollers with UART

## P80CL31; P80CL51

**Table 5** Serial Port Control Register (address 98H)

| 7   | 6   | 5   | 4   | 3   | 2   | 1  | 0  |
|-----|-----|-----|-----|-----|-----|----|----|
| SM0 | SM1 | SM2 | REN | TB8 | RB8 | TI | RI |

**Table 6** Description of SOCON bits

| BIT | SYMBOL | DESCRIPTION  |
|-----|--------|--|
| 7   | SM0    | These bits are used to select the serial port mode; see Table 7.   |
| 6   | SM1    |  |
| 5   | SM2    | Enables the multiprocessor communication feature in Modes 2 and 3. In these modes, if SM2 = 1, then RI will not be activated if the received 9 <sup>th</sup> data bit (RB8) is a logic 0. In Mode 1, if SM2 = 1, then RI will not be activated unless a valid stop bit was received. In Mode 0, SM2 should be a logic 0. |
| 4   | REN    | Enables serial reception and is set by software to enable reception, and cleared by software to disable reception.   |
| 3   | TB8    | Is the 9 <sup>th</sup> data bit that will be transmitted in Modes 2 and 3; set or cleared by software as desired.  |
| 2   | RB8    | In Modes 2 and 3, is the 9 <sup>th</sup> data bit received. In Mode 1, if SM2 = 0 then RB8 is the stop bit that was received; in Mode 0, RB8 is not used.  |
| 1   | TI     | <b>The transmit interrupt flag.</b> Set by hardware at the end of the 8 <sup>th</sup> bit time in Mode 0, or at the beginning of the stop bit time in the other modes, in any serial transmission. Must be cleared by software.  |
| 0   | RI     | <b>The receive interrupt flag.</b> Set by hardware at the end of the 8 <sup>th</sup> bit time in Mode 0, or halfway through the stop bit time in the other modes, in any serial transmission (except see SM2). Must be cleared by software.  |

**Table 7** Selection of the serial port modes

| SM0 | SM1 | MODE   | DESCRIPTION    | BAUD RATE                                       |
|-----|-----|--------|----------------|---|
| 0   | 0   | Mode 0 | Shift register | $\frac{1}{12} \times f_{osc}$                   |
| 0   | 1   | Mode 1 | 8-bit UART     | variable  |
| 1   | 0   | Mode 2 | 9-bit UART     | $\frac{1}{32}$ or $\frac{1}{64} \times f_{osc}$ |
| 1   | 1   | Mode 3 | 9-bit UART     | variable  |

## Low voltage 8-bit microcontrollers with UART

P80CL31; P80CL51

### 13.3 Baud rates

The baud rate in Mode 0 is fixed and may be calculated as:

$$\text{Baud Rate} = \frac{f_{\text{osc}}}{12}$$

The baud rate in Mode 2 depends on the value of the SMOD bit in Special Function Register PCON and may be calculated as:

$$\text{Baud Rate} = \frac{2^{\text{SMOD}}}{64} \times f_{\text{osc}}$$

- If SMOD = 0 (value on reset), the baud rate is  $\frac{1}{64} \times f_{\text{osc}}$
- If SMOD = 1, the baud rate is  $\frac{1}{32} \times f_{\text{osc}}$

The baud rates in Modes 1 and 3 are determined by the Timer 1 or Timer 2 overflow rate.

#### 13.3.1 USING TIMER 1 TO GENERATE BAUD RATES

When Timer 1 is used as the Baud Rate Generator, the baud rates in Modes 1 and 3 are determined by the Timer 1 overflow rate and the value of the SMOD bit as

follows:

$$\text{Baud Rate} = \frac{2^{\text{SMOD}}}{32} \times \text{Timer 1 Overflow Rate.}$$

The Timer 1 interrupt should be disabled in this application. The Timer itself can be configured for either 'timer' or 'counter' operation in any of its 3 running modes. In most typical applications, it is configured for 'timer' operation, in the Auto-reload mode (high nibble of TMOD = 0010B). In this case the baud rate is given by the formula:

$$\text{Baud Rate} = \frac{2^{\text{SMOD}}}{32} \times \frac{f_{\text{osc}}}{\{12 \times (256 - \text{TH1})\}}$$

By configuring Timer 1 to run as a 16-bit timer (high nibble of TMOD = 0001B), and using the Timer 1 interrupt to do a 16-bit software reload, very low baud rates can be achieved. Table 8 lists commonly used baud rates and how they can be obtained from Timer 1.

**Table 8** Commonly used baud rates generated by Timer 1

| BAUD RATE (kbits/s)   | f <sub>osc</sub> (MHz) | SMOD             | C/T | TIMER 1 MODE | RELOAD VALUE |
|-----------------------|------------------------|------------------|-----|--------------|--------------|
| 1330.0 <sup>(1)</sup> | 16.000                 | X <sup>(2)</sup> | X   | X            | X            |
| 500.0 <sup>(3)</sup>  | 16.000                 | 1                | X   | X            | X            |
| 83.3 <sup>(4)</sup>   | 16.000                 | 1                | 0   | Mode 2       | FFH          |
| 19.2                  | 11.059                 | 1                | 0   | Mode 2       | FDH          |
| 9.6                   | 11.059                 | 0                | 0   | Mode 2       | FDH          |
| 4.8                   | 11.059                 | 0                | 0   | Mode 2       | FAH          |
| 2.4                   | 11.059                 | 0                | 0   | Mode 2       | F4H          |
| 1.2                   | 11.059                 | 0                | 0   | Mode 2       | E8H          |
| 137.5                 | 11.986                 | 0                | 0   | Mode 2       | 1DH          |
| 110.0                 | 6.000                  | 0                | 0   | Mode 2       | 72H          |
| 110.0                 | 12.000                 | 0                | 0   | Mode 1       | FEEBH        |

#### Notes

1. Maximum in Mode 0.
2. X = don't care.
3. Maximum in Mode 2.
4. Maximum in Modes 1 and 3.

# Low voltage 8-bit microcontrollers with UART

P80CL31; P80CL51

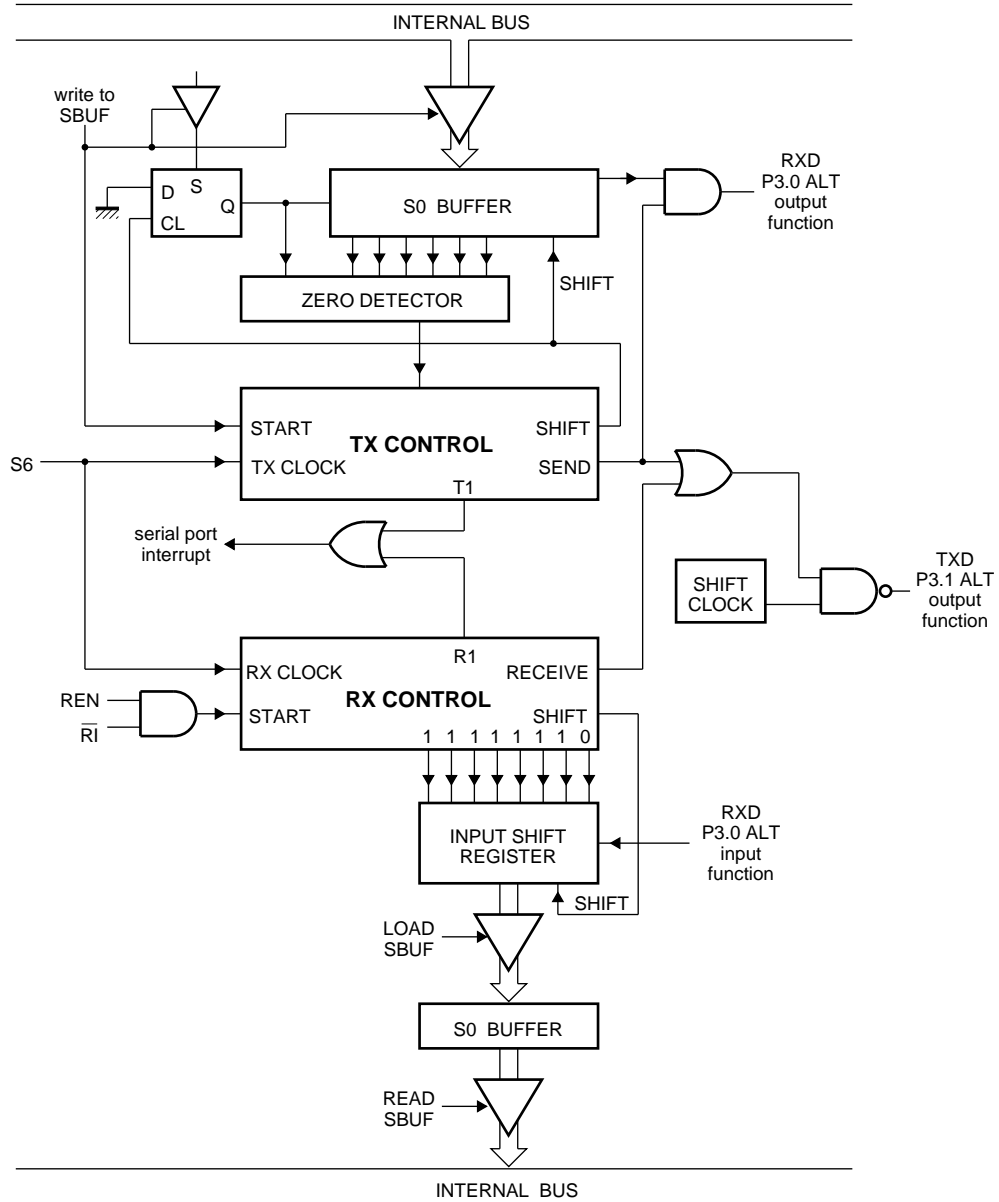

MGC752

Fig.11 Serial port Mode 0.

# Low voltage 8-bit microcontrollers with UART

## P80CL31; P80CL51

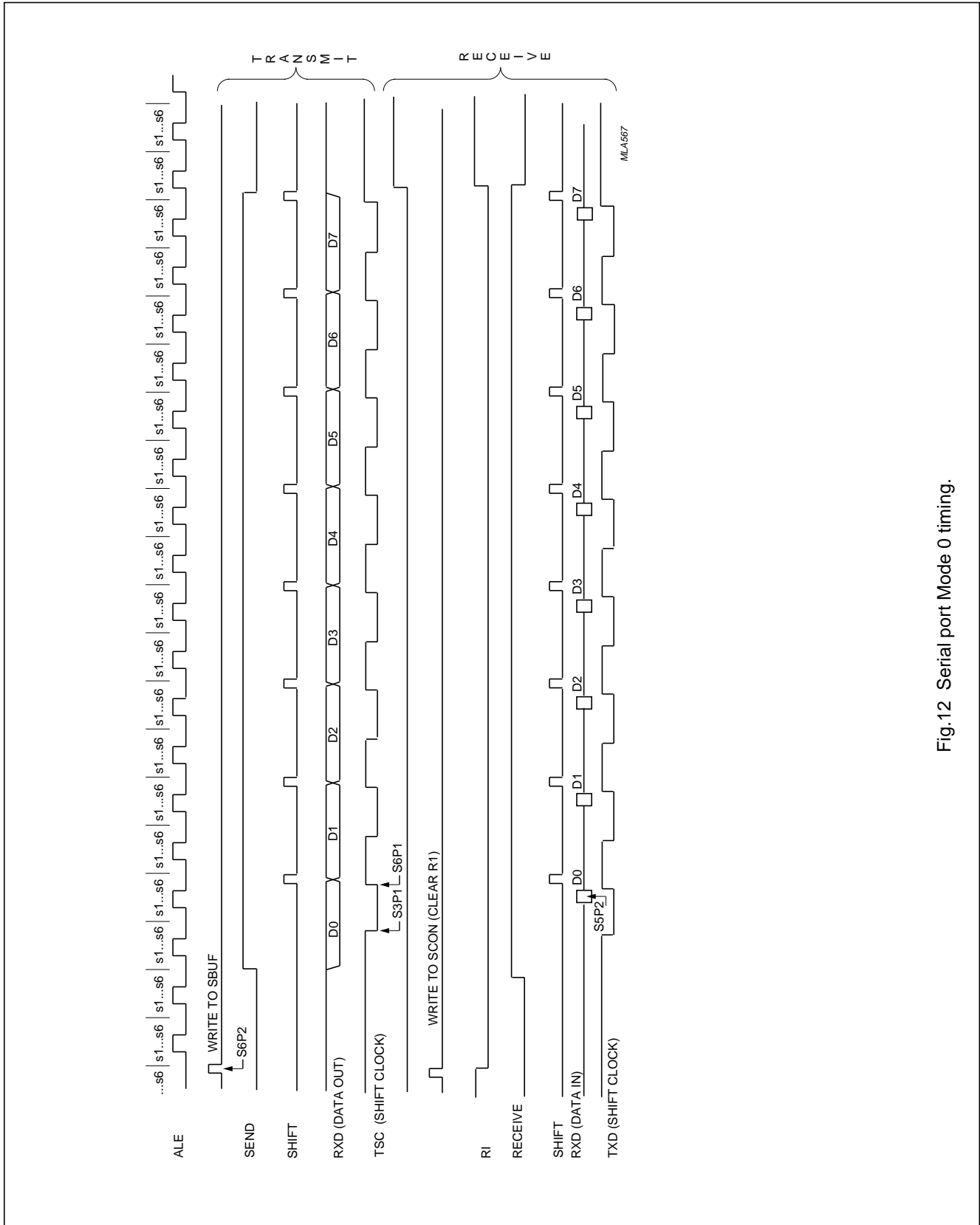
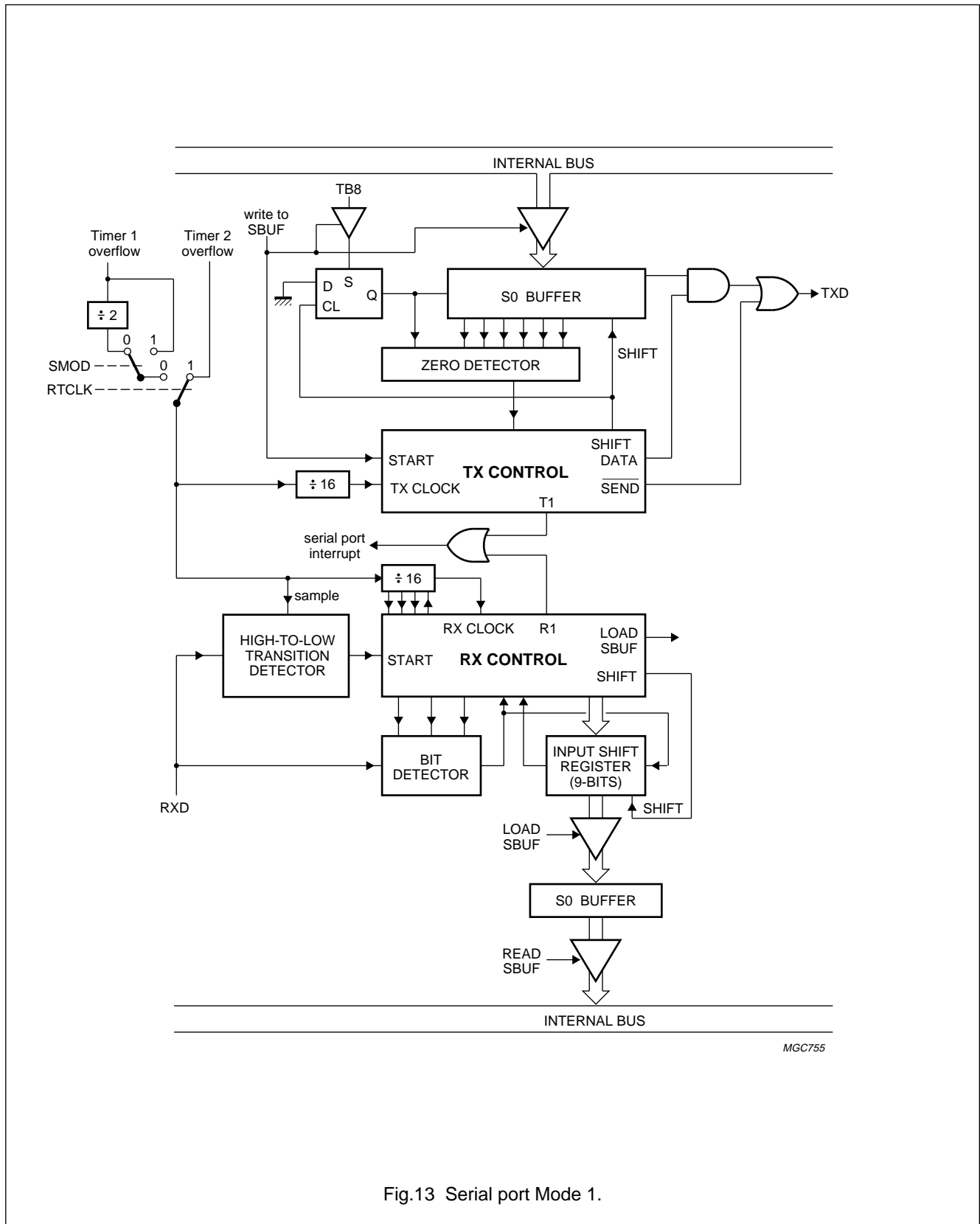

Fig.12 Serial port Mode 0 timing.



Low voltage 8-bit microcontrollers with  
UART

P80CL31; P80CL51



MGC755

Fig.13 Serial port Mode 1.

Low voltage 8-bit microcontrollers with  
UART

P80CL31; P80CL51

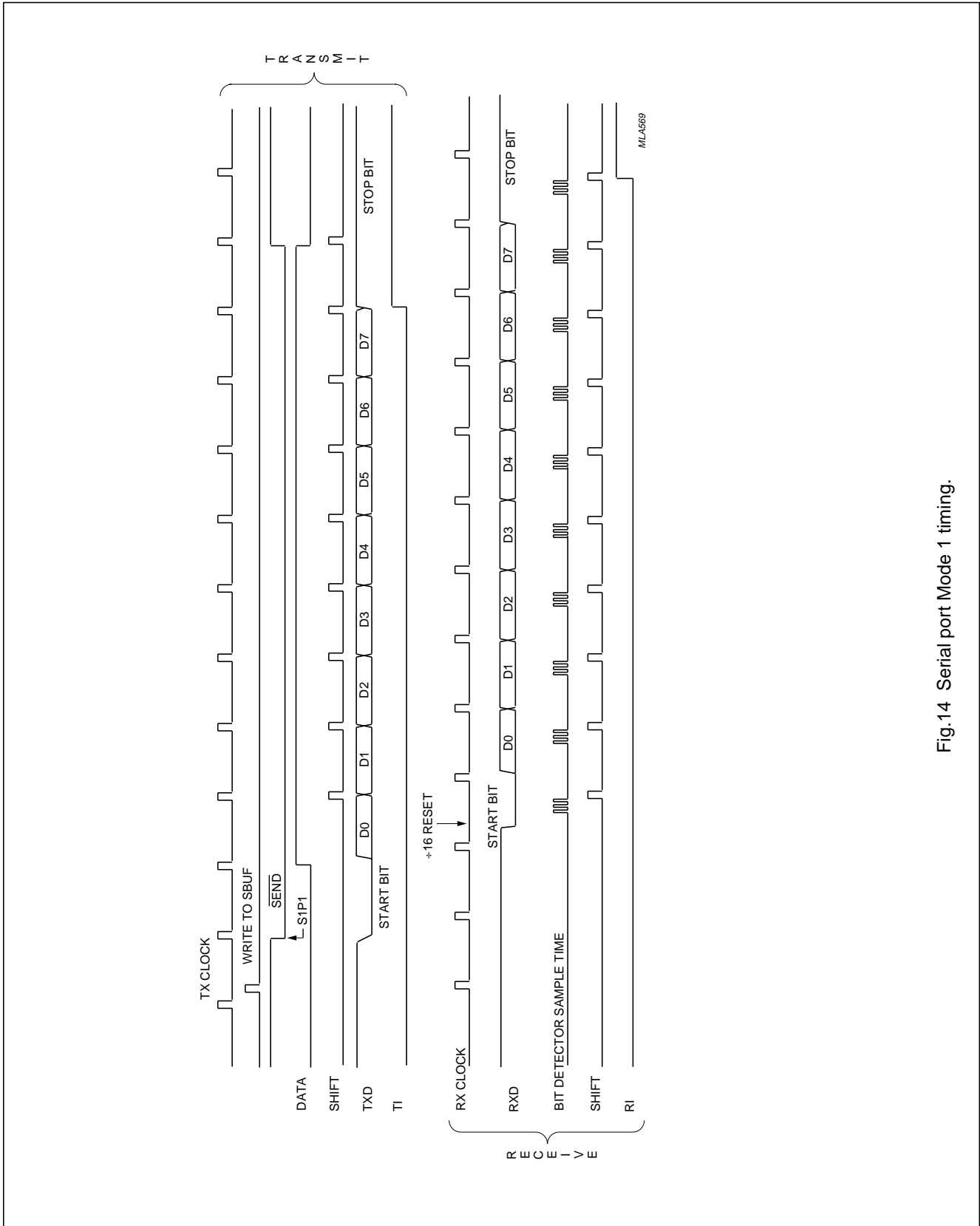
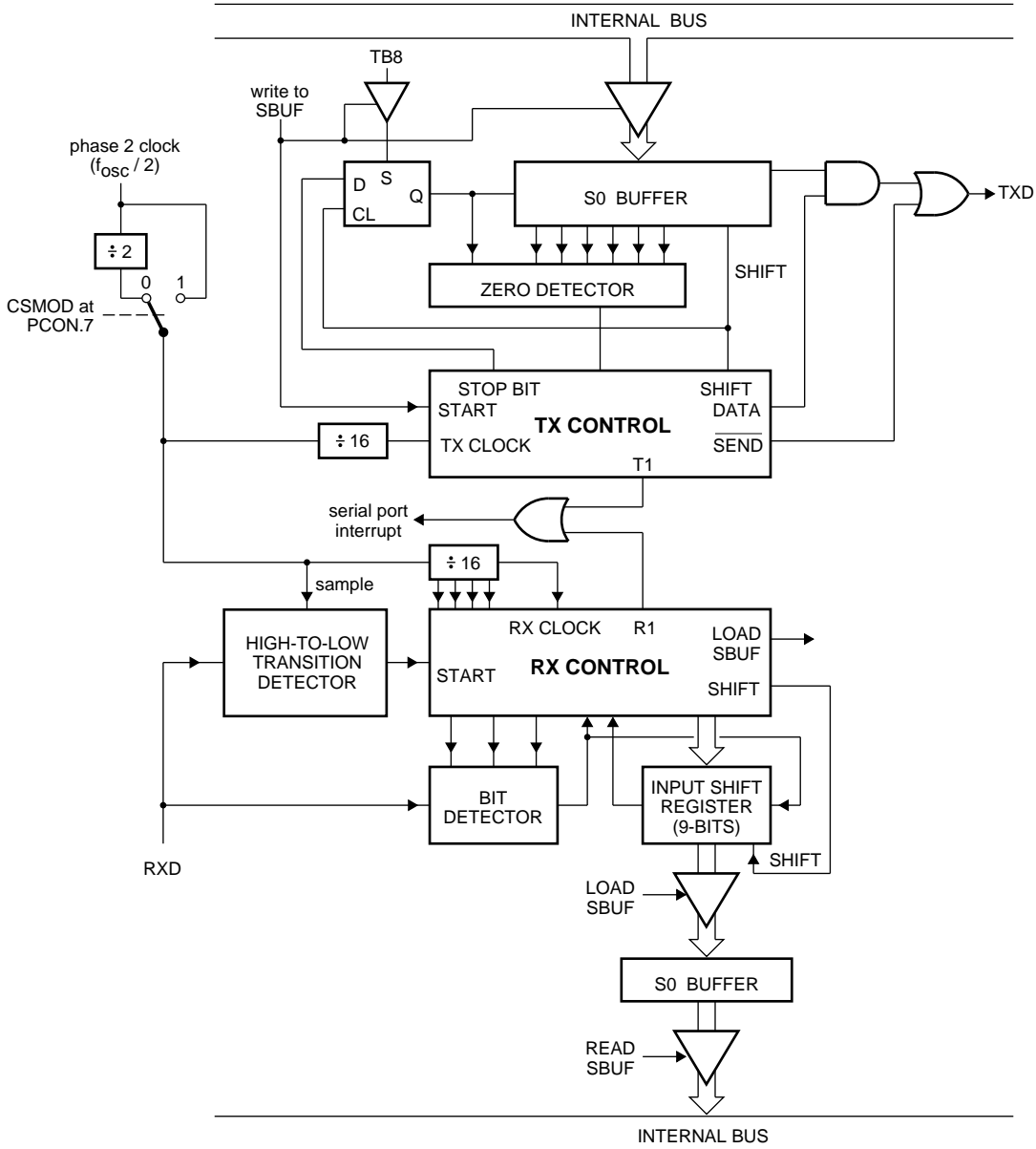

Fig.14 Serial port Mode 1 timing.

# Low voltage 8-bit microcontrollers with UART

P80CL31; P80CL51



MGC754

Fig.15 Serial port Mode 2.

Low voltage 8-bit microcontrollers with UART

P80CL31; P80CL51

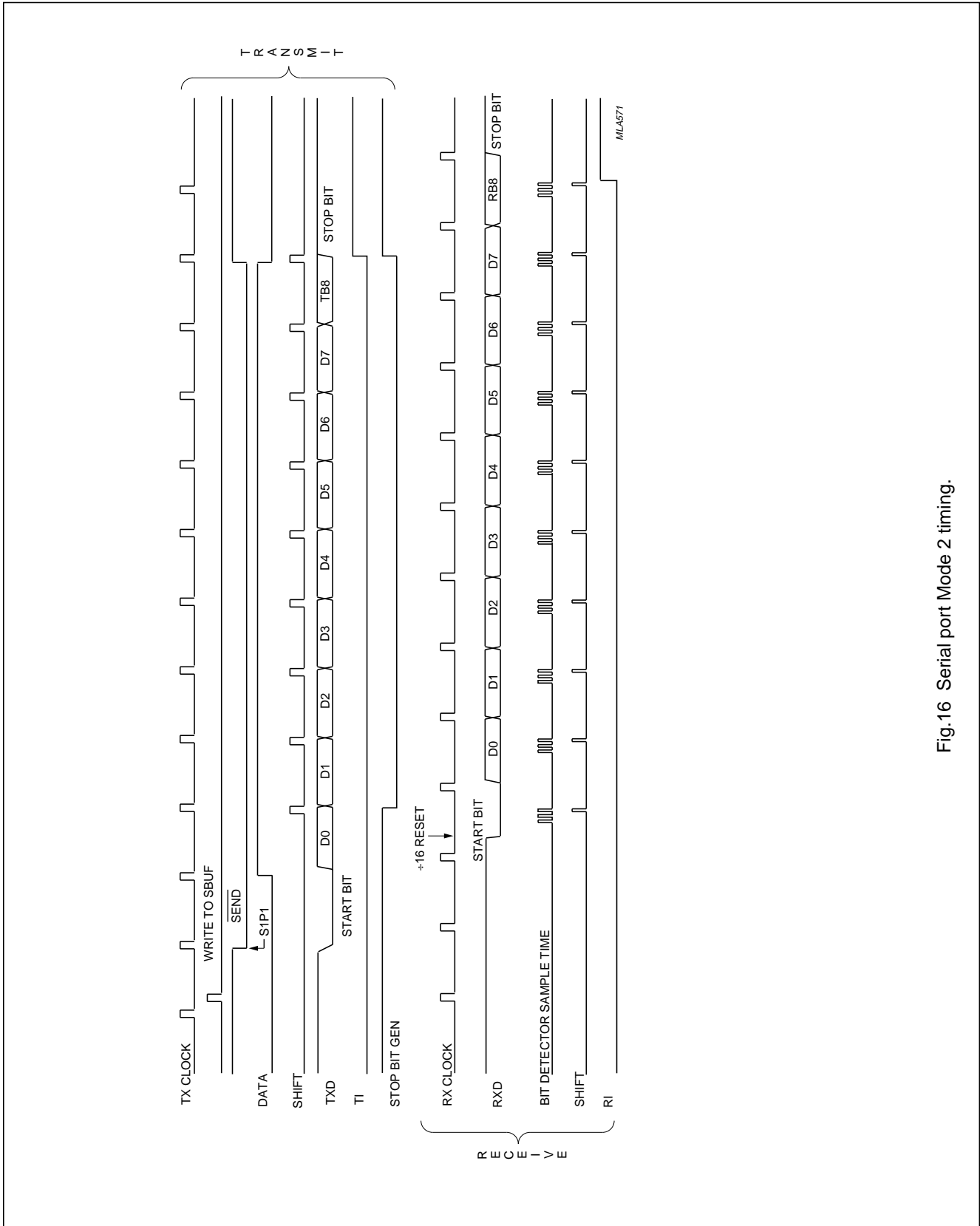
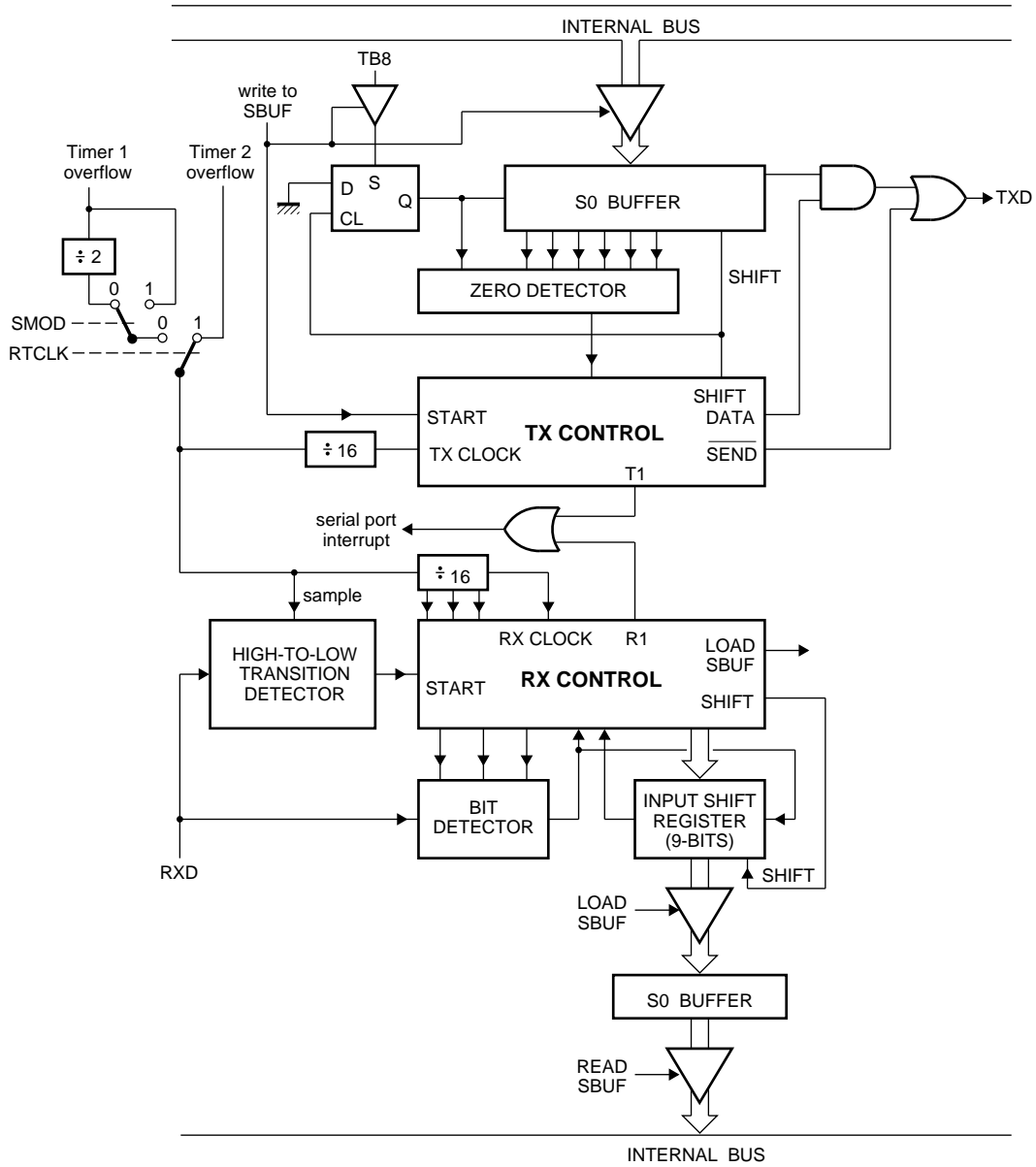

Fig.16 Serial port Mode 2 timing.

# Low voltage 8-bit microcontrollers with UART

P80CL31; P80CL51



MGC753

Fig.17 Serial port Mode 3.

# Low voltage 8-bit microcontrollers with UART

## P80CL31; P80CL51

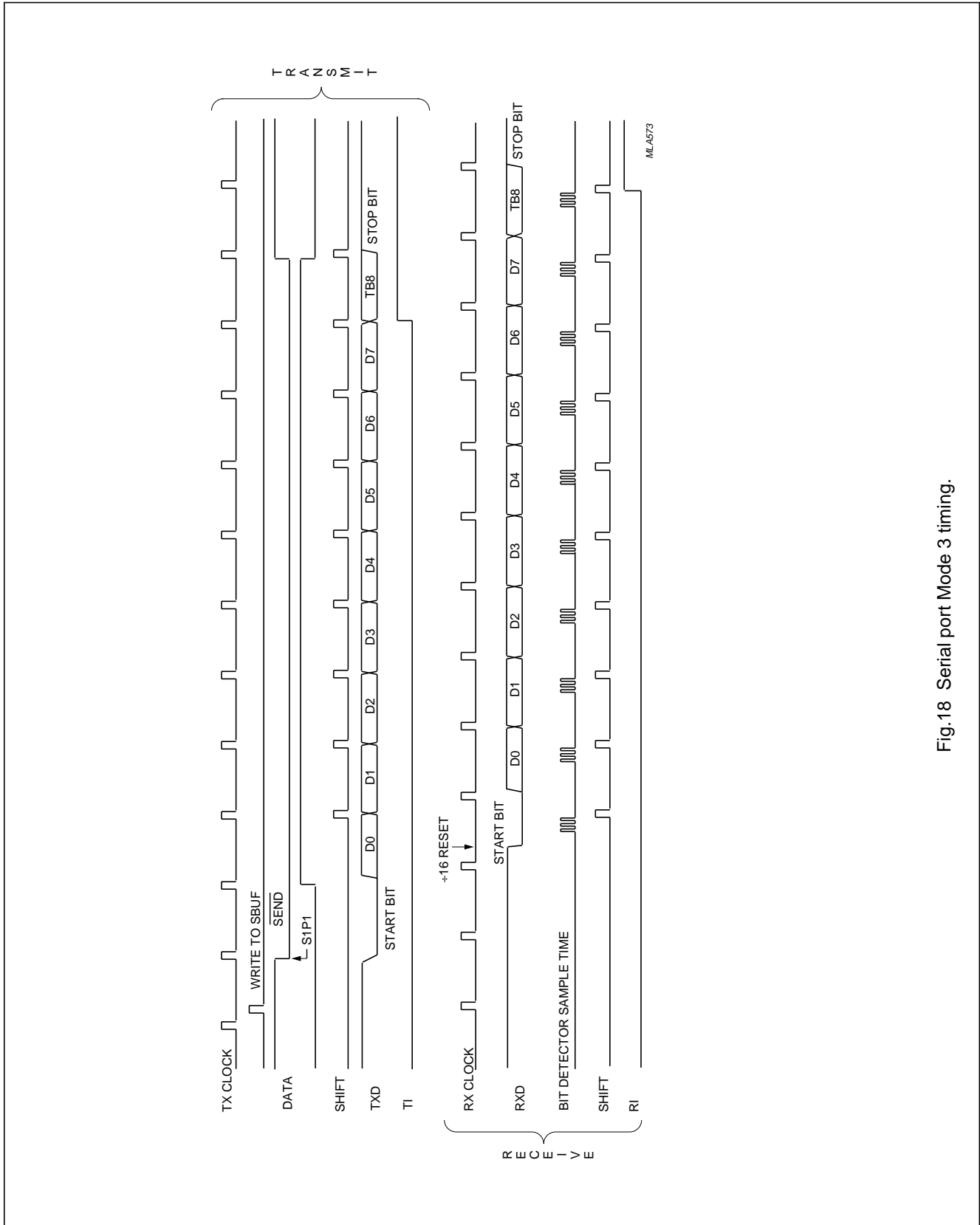

Fig.18 Serial port Mode 3 timing.

# Low voltage 8-bit microcontrollers with UART

## P80CL31; P80CL51

### 14 INTERRUPT SYSTEM

External events and the real-time-driven on-chip peripherals require service by the CPU at unpredictable times. To tie the asynchronous activities of these functions to normal program execution a multiple-source, two-priority-level, nested interrupt system is provided. The system is shown in Fig.19. The P80CLx1 acknowledges interrupt requests from thirteen sources as follows:

- $\overline{INT0}$  to  $\overline{INT9}$
- Timer 0 and Timer 1
- UART.

Each interrupt vectors to a separate location in Program Memory for its service routine. Each source can be individually enabled or disabled by corresponding bits in the Interrupt Enable Registers (IEN0 and IEN1). The priority level is selected via the Interrupt Priority Registers (IP0 and IP1). All enabled sources can be globally disabled or enabled. Figure 19 shows the interrupt system.

#### 14.1 External interrupts $\overline{INT2}$ to $\overline{INT9}$

Port 1 lines serve an alternative purpose as eight additional interrupts  $\overline{INT2}$  to  $\overline{INT9}$ . When enabled, each of these lines may wake-up the device from the Power-down mode. Using the Interrupt Polarity Register (IX1), each pin may be initialized to be either active HIGH or active LOW. IRQ1 is the Interrupt Request Flag Register. If the interrupt is enabled, each flag will be set on an interrupt request but must be cleared by software, i.e. via the interrupt software or when the interrupt is disabled.

Port 1 interrupts are level sensitive. A Port 1 interrupt will be recognized when a level (HIGH or LOW depending on the Interrupt Polarity Register) on P1.n is held active for at least one machine cycle. The interrupt request is not serviced until the next machine cycle. Figure 20 shows the external interrupt configuration.

#### 14.2 Interrupt priority

Each interrupt source can be set to either a high priority or to a low priority. If a low priority interrupt is received simultaneously with a high priority interrupt, the high priority interrupt will be dealt with first.

If interrupts of the same priority are requested simultaneously, the processor will branch to the interrupt polled first, according to the sequence shown in Table 9 and in Fig.19. The 'vector address' is the ROM location where the appropriate interrupt service routine starts.

**Table 9** Interrupt vector polling sequence

| SYMBOL     | VECTOR ADDRESS (HEX) | SOURCE     |
|------------|----------------------|------------|
| X0 (first) | 0003                 | External 0 |
| S0         | 002B                 | UART       |
| X5         | 0053                 | External 5 |
| T0         | 000B                 | Timer 0    |
| X6         | 005B                 | External 6 |
| X1         | 0013                 | External 1 |
| X2         | 003B                 | External 2 |
| X7         | 0063                 | External 7 |
| T1         | 001B                 | Timer 1    |
| X3         | 0043                 | External 3 |
| X8         | 006B                 | External 8 |
| X4         | 004B                 | External 4 |
| X9 (last)  | 0073                 | External 9 |

A low priority interrupt routine can only be interrupted by a high priority interrupt. A high priority interrupt routine cannot be interrupted.

Low voltage 8-bit microcontrollers with  
UART

P80CL31; P80CL51

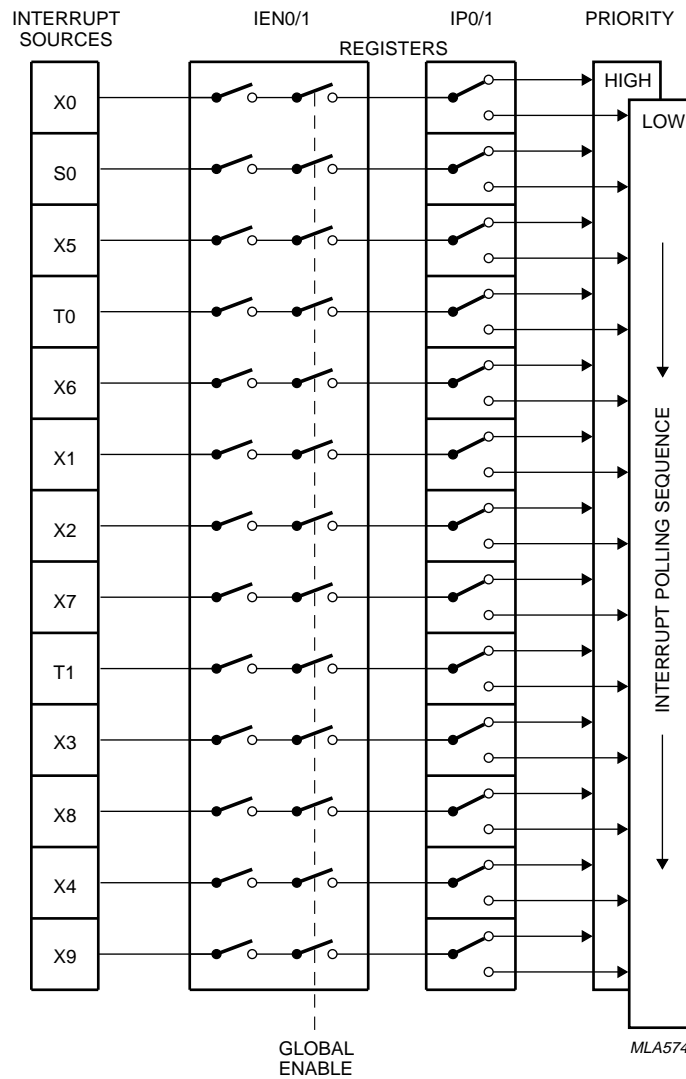

MLA574

Fig.19 Interrupt system.



Low voltage 8-bit microcontrollers with  
UART

P80CL31; P80CL51

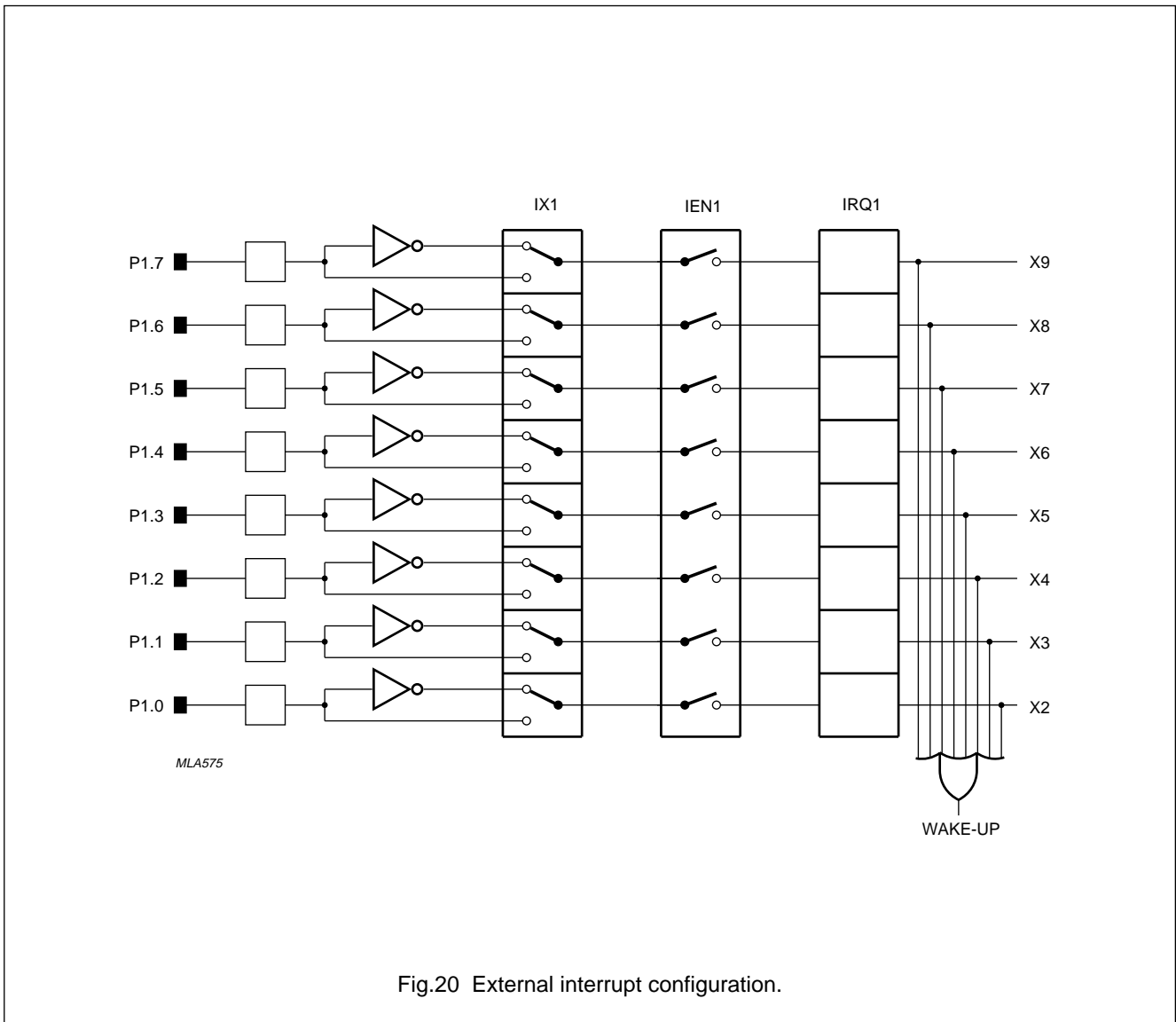

14.3 Interrupt registers

The registers used in the interrupt system are listed in Table 10. Tables 11 to 22 describe the contents of these registers.

Table 10 Special Function Registers related to the interrupt system

| ADDRESS | REGISTER | DESCRIPTION  |
|---------|----------|--|
| A8H     | IEN0     | Interrupt Enable Register  |
| E8H     | IEN1     | Interrupt Enable Register ( $\overline{\text{INT2}}$ to $\overline{\text{INT9}}$ )   |
| B8H     | IP0      | Interrupt Priority Register  |
| F8H     | IP1      | Interrupt Priority Register ( $\overline{\text{INT2}}$ to $\overline{\text{INT9}}$ ) |
| E9H     | IX1      | Interrupt Polarity Register  |
| C0H     | IRQ1     | Interrupt Request Flag Register  |

## Low voltage 8-bit microcontrollers with UART

P80CL31; P80CL51

### 14.3.1 INTERRUPT ENABLE REGISTER (IEN0)

Bit values: 0 = interrupt disabled; 1 = interrupt enabled.

**Table 11** Interrupt Enable Register (SFR address A8H)

|          |          |          |          |          |          |          |          |
|----------|----------|----------|----------|----------|----------|----------|----------|
| <b>7</b> | <b>6</b> | <b>5</b> | <b>4</b> | <b>3</b> | <b>2</b> | <b>1</b> | <b>0</b> |
| EA       | –        | –        | ES0      | ET1      | EX1      | ET0      | EX0      |

**Table 12** Description of IEN0 bits

| <b>BIT</b> | <b>SYMBOL</b> | <b>DESCRIPTION</b>   |
|------------|---------------|--|
| 7          | EA            | general enable/disable control. If EA = 0, no interrupt is enabled; if EA = 1, any individually enabled interrupt will be accepted |
| 6          | –             | reserved   |
| 5          | –             | reserved   |
| 4          | ES0           | enable UART SIO interrupt  |
| 3          | ET1           | enable Timer 1 interrupt (T1)  |
| 2          | EX1           | enable external interrupt 1  |
| 1          | ET0           | enable Timer 0 interrupt (T0)  |
| 0          | EX0           | enable external interrupt 0  |

### 14.3.2 INTERRUPT ENABLE REGISTER (IEN1)

Bit values: 0 = interrupt disabled; 1 = interrupt enabled.

**Table 13** Interrupt Enable Register (SFR address E8H)

|          |          |          |          |          |          |          |          |
|----------|----------|----------|----------|----------|----------|----------|----------|
| <b>7</b> | <b>6</b> | <b>5</b> | <b>4</b> | <b>3</b> | <b>2</b> | <b>1</b> | <b>0</b> |
| EX9      | EX8      | EX7      | EX6      | EX5      | EX4      | EX3      | EX2      |

**Table 14** Description of IEN1 bits

| <b>BIT</b> | <b>SYMBOL</b> | <b>DESCRIPTION</b>          |
|------------|---------------|-----------------------------|
| 7          | EX9           | enable external interrupt 9 |
| 6          | EX8           | enable external interrupt 8 |
| 5          | EX7           | enable external interrupt 7 |
| 4          | EX6           | enable external interrupt 6 |
| 3          | EX5           | enable external interrupt 5 |
| 2          | EX4           | enable external interrupt 4 |
| 1          | EX3           | enable external interrupt 3 |
| 0          | EX2           | enable external interrupt 2 |

## Low voltage 8-bit microcontrollers with UART

P80CL31; P80CL51

### 14.3.3 INTERRUPT PRIORITY REGISTER (IP0)

Bit values: 0 = low priority; 1 = high priority.

**Table 15** Interrupt Priority Register (SFR address B8H)

| 7 | 6 | 5 | 4   | 3   | 2   | 1   | 0   |
|---|---|---|-----|-----|-----|-----|-----|
| – | – | – | PS0 | PT1 | PX1 | PT0 | PX0 |

**Table 16** Description of IP0 bits

| BIT | SYMBOL | DESCRIPTION                         |
|-----|--------|-------------------------------------|
| 7   | –      | reserved                            |
| 6   | –      | reserved                            |
| 5   | –      | reserved                            |
| 4   | PS0    | UART SIO interrupt priority level   |
| 3   | PT1    | Timer 1 interrupt priority level    |
| 2   | PX1    | external interrupt 1 priority level |
| 1   | PT0    | Timer 0 interrupt priority level    |
| 0   | PX0    | external interrupt 0 priority level |

### 14.3.4 INTERRUPT PRIORITY REGISTER (IP1)

Bit values: 0 = low priority; 1 = high priority.

**Table 17** Interrupt Priority Register (SFR address F8H)

| 7   | 6   | 5   | 4   | 3   | 2   | 1   | 0   |
|-----|-----|-----|-----|-----|-----|-----|-----|
| PX9 | PX8 | PX7 | PX6 | PX5 | PX4 | PX3 | PX2 |

**Table 18** Description of IP1 bits

| BIT | SYMBOL | DESCRIPTION                         |
|-----|--------|-------------------------------------|
| 7   | PX9    | external interrupt 9 priority level |
| 6   | PX8    | external interrupt 8 priority level |
| 5   | PX7    | external interrupt 7 priority level |
| 4   | PX6    | external interrupt 6 priority level |
| 3   | PX5    | external interrupt 5 priority level |

## Low voltage 8-bit microcontrollers with UART

P80CL31; P80CL51

| BIT | SYMBOL | DESCRIPTION                         |
|-----|--------|-------------------------------------|
| 2   | PX4    | external interrupt 4 priority level |
| 1   | PX3    | external interrupt 3 priority level |
| 0   | PX2    | external interrupt 2 priority level |

### 14.3.5 INTERRUPT POLARITY REGISTER (IX1)

Writing either a logic 1 or logic 0 to any Interrupt Polarity Register bit sets the polarity level of the corresponding external interrupt to an active HIGH or active LOW respectively.

**Table 19** Interrupt Polarity Register (SFR address E9H)

| 7   | 6   | 5   | 4   | 3   | 2   | 1   | 0   |
|-----|-----|-----|-----|-----|-----|-----|-----|
| IL9 | IL8 | IL7 | IL6 | IL5 | IL4 | IL3 | IL2 |

**Table 20** Description of IX1 bits

| BIT | SYMBOL | DESCRIPTION                         |
|-----|--------|-------------------------------------|
| 7   | IL9    | external interrupt 9 polarity level |
| 6   | IL8    | external interrupt 8 polarity level |
| 5   | IL7    | external interrupt 7 polarity level |
| 4   | IL6    | external interrupt 6 polarity level |
| 3   | IL5    | external interrupt 5 polarity level |
| 2   | IL4    | external interrupt 4 polarity level |
| 1   | IL3    | external interrupt 3 polarity level |
| 0   | IL2    | external interrupt 2 polarity level |

### 14.3.6 INTERRUPT REQUEST FLAG REGISTER (IRQ1)

**Table 21** Interrupt Request Flag Register (SFR address C0H)

| 7   | 6   | 5   | 4   | 3   | 2   | 1   | 0   |
|-----|-----|-----|-----|-----|-----|-----|-----|
| IQ9 | IQ8 | IQ7 | IQ6 | IQ5 | IQ4 | IQ3 | IQ2 |

**Table 22** Description of IRQ1 bits

| BIT | SYMBOL | DESCRIPTION                       |
|-----|--------|-----------------------------------|
| 7   | IQ9    | external interrupt 9 request flag |
| 6   | IQ8    | external interrupt 8 request flag |
| 5   | IQ7    | external interrupt 7 request flag |
| 4   | IQ6    | external interrupt 6 request flag |
| 3   | IQ5    | external interrupt 5 request flag |
| 2   | IQ4    | external interrupt 4 request flag |
| 1   | IQ3    | external interrupt 3 request flag |
| 0   | IQ2    | external interrupt 2 request flag |

# Low voltage 8-bit microcontrollers with UART

## P80CL31; P80CL51

### 15 OSCILLATOR CIRCUITRY

The on-chip oscillator circuitry of the P80CLx1 is a single-stage inverting amplifier biased by an internal feedback resistor. The oscillator circuit is shown in Fig.22. For operation as a standard quartz oscillator, no external components are needed, except for the 32 kHz option. When using external capacitors, ceramic resonators, coils and RC networks to drive the oscillator, five different configurations are supported (see Table 23 and Fig.21).

In the Power-down mode the oscillator is stopped and XTAL1 is pulled HIGH. The oscillator inverter is switched off to ensure no current will flow regardless of the voltage at XTAL1, for configurations (a), (b), (c), (d), (e) and (g) of Fig.21.

To drive the device with an external clock source, apply the external clock signal to XTAL1, and leave XTAL2 to float, as shown in Fig.21(f). There are no requirements on the duty cycle of the external clock, since the input to the internal clocking circuitry is buffered by a flip-flop.

Various oscillator options are provided for optimum on-chip oscillator performance; these are specified in Table 23 and shown in Fig.21. The required option should be stated when ordering.

**Table 23** Oscillator options

| OPTION        | APPLICATION  |
|---------------|--|
| Oscillator 1  | for 32 kHz clock applications with external trimmer for frequency adjustment; a 4.7 MΩ bias resistor is needed for use in parallel with the crystal; see Fig.21(c) |
| Oscillator 2  | low-power, low-frequency operations using LC components; see Fig.21(e)   |
| Oscillator 3  | medium frequency range applications  |
| Oscillator 4  | high frequency range applications  |
| RC oscillator | RC oscillator configuration; see Figs 21(g) and 23   |

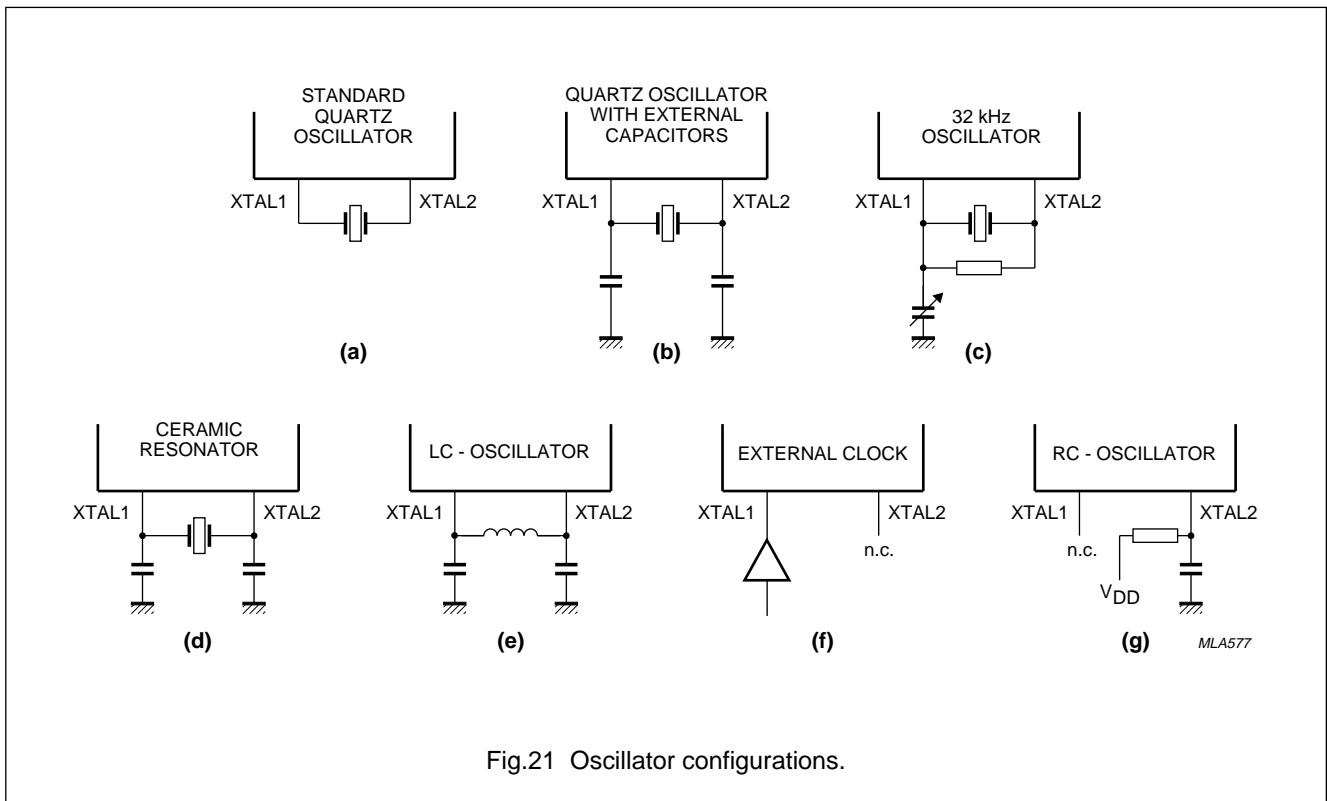

Fig.21 Oscillator configurations.

Low voltage 8-bit microcontrollers with UART

P80CL31; P80CL51

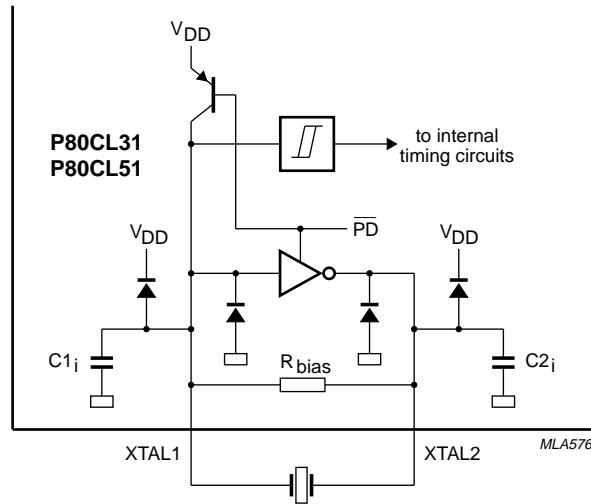
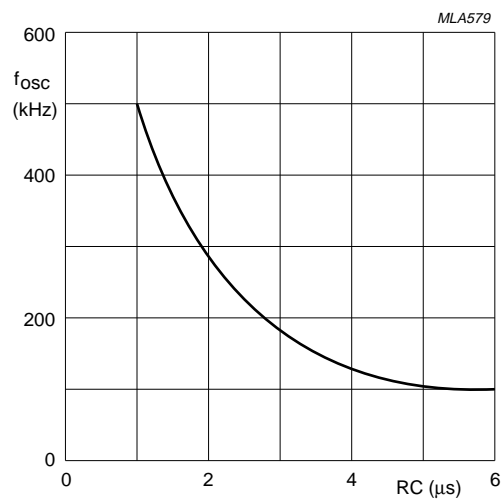

Fig.22 Standard oscillator.



RC oscillator frequency is externally adjustable;  $100 \text{ kHz} \leq f_{osc} \leq 500 \text{ kHz}$ .

Fig.23 RC oscillator frequency as a function of RC.

# Low voltage 8-bit microcontrollers with UART

## P80CL31; P80CL51

**Table 24** Oscillator type selection guide

| RESONATOR | FREQUENCY<br>(MHz) | OPTION<br>(see Table 23) | C1 EXT. (pF) |      | C2 EXT. (pF) |      | RESONATOR MAX.<br>SERIES RESISTANCE        |
|-----------|--------------------|--------------------------|--------------|------|--------------|------|--|
|           |                    |                          | MIN.         | MAX. | MIN.         | MAX. |  |
| Quartz    | 0.032              | Oscillator 1             | 0            | 0    | 5            | 15   | 15 kΩ <sup>(1)</sup>                       |
|           | 1.0                | Oscillator 2             | 0            | 30   | 0            | 30   | 600 Ω                                      |
|           | 3.58               |                          | 0            | 15   | 0            | 15   | 100 Ω                                      |
|           | 4.0                |                          | 0            | 20   | 0            | 20   | 75 Ω                                       |
|           | 6.0                | Oscillator 3             | 0            | 10   | 0            | 10   | 60 Ω                                       |
|           | 10.0               | Oscillator 4             | 0            | 15   | 0            | 15   | 60 Ω                                       |
|           | 12.0               |                          | 0            | 10   | 0            | 10   | 40 Ω                                       |
|           | 16.0               |                          | 0            | 15   | 0            | 15   | 20 Ω                                       |
| PXE       | 0.455              | Oscillator 2             | 40           | 50   | 40           | 50   | 10 Ω                                       |
|           | 1.0                |                          | 15           | 50   | 15           | 50   | 100 Ω                                      |
|           | 3.58               |                          | 0            | 40   | 0            | 40   | 10 Ω                                       |
|           | 4.0                |                          | 0            | 40   | 0            | 40   | 10 Ω                                       |
|           | 6.0                |                          | 0            | 20   | 0            | 20   | 5 Ω  |
|           | 10.0               | Oscillator 3             | 0            | 15   | 0            | 15   | 6 Ω  |
|           | 12.0               | Oscillator 4             | 10           | 40   | 10           | 40   | 6 Ω  |
| LC        | –                  | Oscillator 2             | 20           | 90   | 20           | 90   | 10 μH = 1 Ω<br>100 μH = 5 Ω<br>1 mH = 75 Ω |

**Note**

- 32 kHz quartz crystals with a series resistance >15 kΩ will reduce the guaranteed supply voltage range to 2.5 to 3.5 V.

Low voltage 8-bit microcontrollers with  
UART

P80CL31; P80CL51

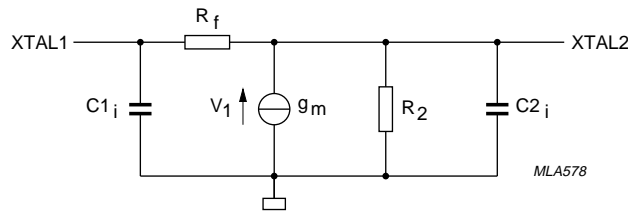

Fig.24 Oscillator equivalent circuit diagram.

**Table 25** Oscillator equivalent circuit parameters

The equivalent circuit data of the internal oscillator compares with that of matched crystals.

| SYMBOL | PARAMETER          | OPTION   | CONDITION   | MIN.                    | TYP.                      | MAX.                       | UNIT   |
|--------|--------------------|--|---|-------------------------|---------------------------|----------------------------|--|
| $g_m$  | transconductance   | Oscillator 1; 32 kHz<br>Oscillator 2<br>Oscillator 3<br>Oscillator 4 | $T_{amb} = +25\text{ }^\circ\text{C};$<br>$V_{DD} = 4.5\text{ V}$ | –<br>200<br>400<br>1000 | 15<br>600<br>1500<br>4000 | –<br>1000<br>4000<br>10000 | $\mu\text{S}$<br>$\mu\text{S}$<br>$\mu\text{S}$<br>$\mu\text{S}$ |
| $C1_i$ | input capacitance  | Oscillator 1; 32 kHz<br>Oscillator 2<br>Oscillator 3<br>Oscillator 4 |   | –<br>–<br>–<br>–        | 3.0<br>8.0<br>8.0<br>8.0  | –<br>–<br>–<br>–           | pF<br>pF<br>pF<br>pF   |
| $C2_i$ | output capacitance | Oscillator 1; 32 kHz<br>Oscillator 2<br>Oscillator 3<br>Oscillator 4 |   | –<br>–<br>–<br>–        | 23<br>8.0<br>8.0<br>8.0   | –<br>–<br>–<br>–           | pF<br>pF<br>pF<br>pF   |
| $R_2$  | output resistance  | Oscillator 1; 32 kHz<br>Oscillator 2<br>Oscillator 3<br>Oscillator 4 |   | –<br>–<br>–<br>–        | 3800<br>65<br>18<br>5.0   | –<br>–<br>–<br>–           | k $\Omega$<br>k $\Omega$<br>k $\Omega$<br>k $\Omega$             |



# Low voltage 8-bit microcontrollers with UART

# P80CL31; P80CL51

## 16 RESET

To initialize the P80CLx1 a reset is performed by either of three methods:

- Applying an external signal to the RST pin
- Via Power-on-reset circuitry.

A reset leaves the internal registers as shown in Chapter 18. The reset state of the port pins is mask-programmable and can be defined by the user.

### 16.1 External reset using the RST pin

The reset input for the P80CLx1 is RST. A Schmitt trigger is used at the input for noise rejection. The output of the Schmitt trigger is sampled by the reset circuitry every machine cycle. A reset is accomplished by holding the RST pin HIGH for at least two machine cycles (24 oscillator periods) while the oscillator is running. The CPU responds by executing an internal reset. Port pins adopt their reset state immediately after the RST goes HIGH. During reset, ALE and  $\overline{\text{PSEN}}$  are held HIGH.

The external reset is asynchronous to the internal clock. The RST pin is sampled during state 5, phase 2 of every machine cycle. After a HIGH is detected at the RST pin, an internal reset is repeated until RST goes LOW. The internal RAM is not affected by reset. When  $V_{DD}$  is turned on, the RAM contents are indeterminate.

### 16.2 Power-on-reset

The device contains on-chip circuitry which switches the port pins to the customer defined logic level as soon as  $V_{DD}$  exceeds 1.3 V; if the mask option 'ON' has been chosen. As soon as the minimum supply voltage is reached, the oscillator will start up. However, to ensure that the oscillator is stable before the controller starts, the clock signals are gated away from the CPU for a further 1536 oscillator periods. During that time the CPU is held in a reset state. A hysteresis of approximately 50 mV at a typical power-on switching level of 1.3 V will ensure correct operation (see Fig.27).

The on-chip Power-on-reset circuitry can also be switched off via the mask option 'OFF'. This option reduces the Power-down current to typically 800 nA and can be chosen if external reset circuitry is used. For applications not requiring the internal reset, option 'OFF' should be chosen.

An automatic reset can be obtained by connecting the RST pin to  $V_{DD}$  via a 10  $\mu\text{F}$  capacitor. At power-on, the voltage on the RST pin is equal to  $V_{DD}$  minus the capacitor voltage, and decreases from  $V_{DD}$  as the capacitor charges through the internal resistor ( $R_{RST}$ ) to ground. The larger the capacitor, the more slowly  $V_{RST}$  decreases.  $V_{RST}$  must remain above the lower threshold of the Schmitt trigger long enough to effect a complete reset. The time required is the oscillator start-up time, plus 2 machine cycles. The Power-on-reset circuitry is shown in Fig.26.

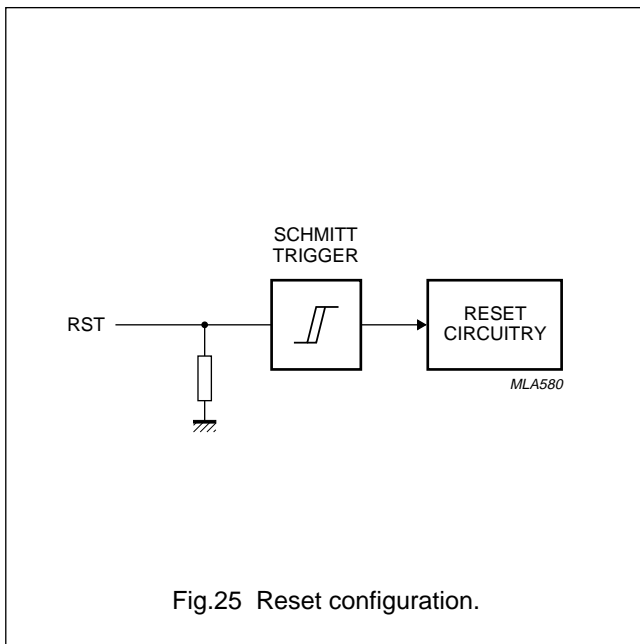

Fig.25 Reset configuration.

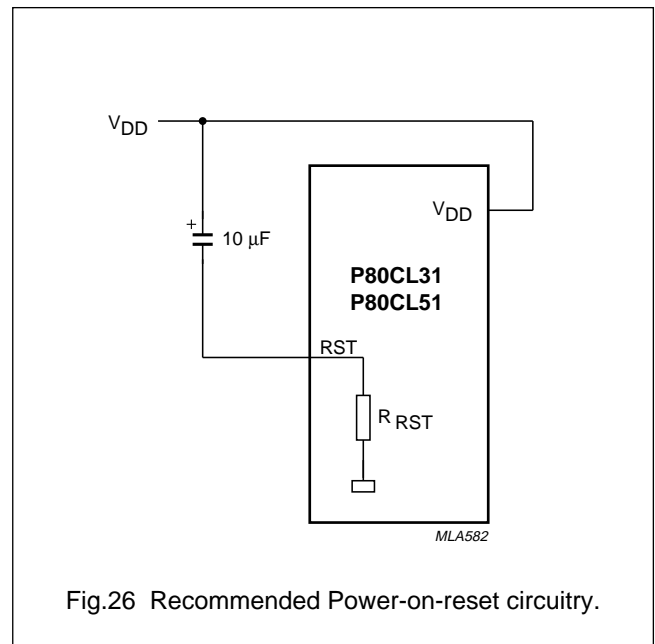

Fig.26 Recommended Power-on-reset circuitry.

Low voltage 8-bit microcontrollers with UART

P80CL31; P80CL51

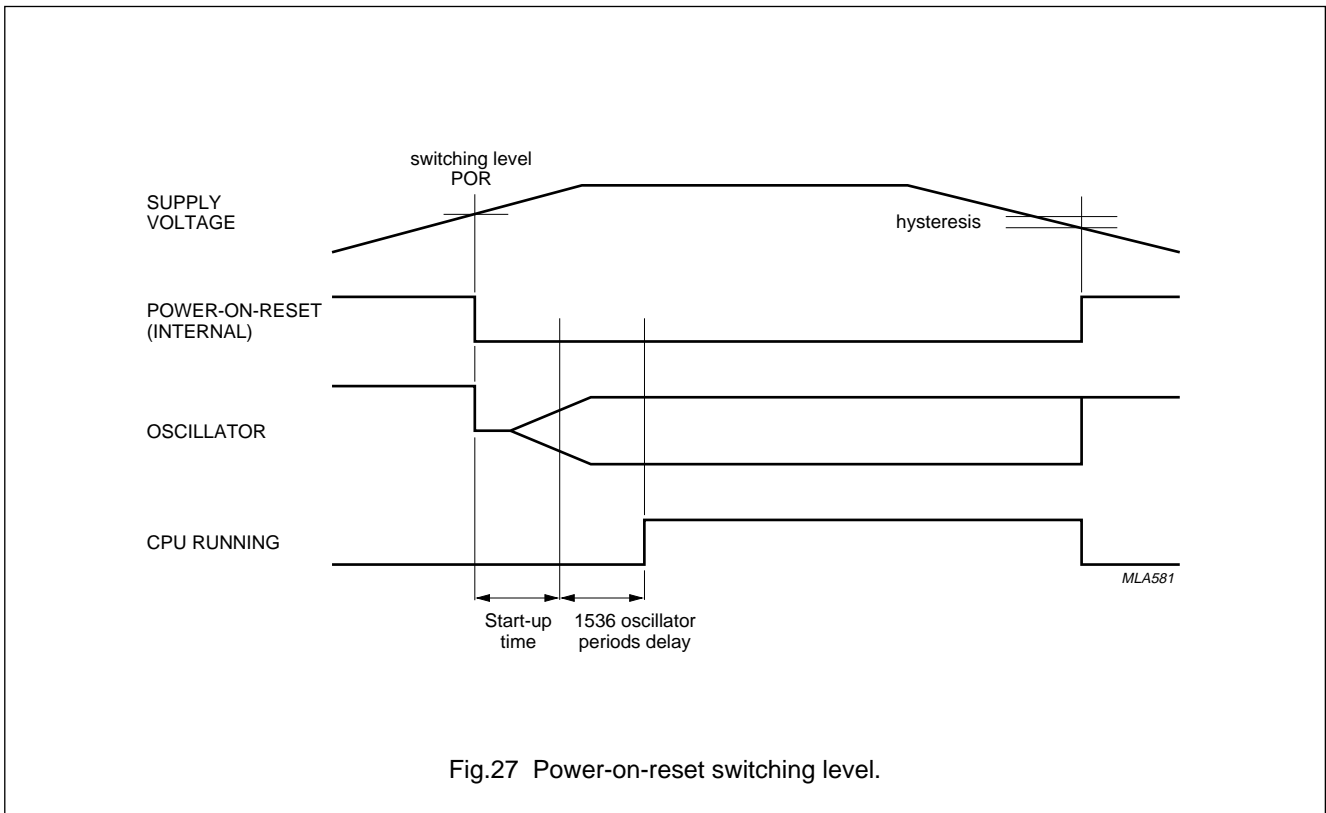

Fig.27 Power-on-reset switching level.

**17 MASK OPTIONS FOR P80CL31 AND P80C51**

**17.1 P80CL31: ROMless version**

The P80CL31 is a low voltage ROMless version of the P80CL51 microcontroller. The mask options for the P80CL31 are fixed as follows:

- Port options: all ports have option "1S", i.e. standard port, HIGH after reset
- Oscillator option: Oscillator 3
- Power-on-reset option: OFF.

**17.2 P80C51: 5 V standard version**

The P80C51 is a 5 V version of the low voltage P80CL51 microcontroller. All functional features of the P80CL51 are maintained in the P80C51 with the exception of the mask options. The mask options on the P80C51 are fixed as follows:

- Port options: all ports have option "1S", i.e. standard port, HIGH after reset
- Oscillator option: Oscillator 3
- Power-on-reset option: OFF.

# Low voltage 8-bit microcontrollers with UART

## P80CL31; P80CL51

### 18 SPECIAL FUNCTION REGISTERS OVERVIEW

The P80CLx1 has 25 SFRs available to the user.

| ADDRESS (HEX) | NAME                 | RESET VALUE (B)         | FUNCTION   |
|---------------|----------------------|-------------------------|--|
| F8            | IP1 <sup>(1)</sup>   | 00000000                | Interrupt Priority Register ( $\overline{\text{INT2}}$ to $\overline{\text{INT9}}$ ) |
| F0            | B <sup>(1)</sup>     | 00000000                | B Register   |
| E9            | IX1                  | 00000000                | Interrupt Polarity Register  |
| E8            | IEN1 <sup>(1)</sup>  | 00000000                | Interrupt Enable Register 1  |
| E0            | ACC <sup>(1)</sup>   | 00000000                | Accumulator  |
| D0            | PSW <sup>(1)</sup>   | 00000000                | Program Status Word  |
| C0            | IRQ1 <sup>(1)</sup>  | 00000000                | Interrupt Request Flag Register  |
| B8            | IP0 <sup>(1)</sup>   | X0000000                | Interrupt Priority Register 0  |
| B0            | P3 <sup>(1)</sup>    | XXXXXXXX <sup>(2)</sup> | Digital I/O Port Register 3  |
| A8            | IEN0 <sup>(1)</sup>  | 00000000                | Interrupt Enable Register  |
| A0            | P2 <sup>(1)</sup>    | XXXXXXXX <sup>(2)</sup> | Digital I/O Port Register 2  |
| 99            | S0BUF                | XXXXXXXX                | Serial Data Buffer Register 0  |
| 98            | S0CON <sup>(1)</sup> | 00000000                | Serial Port Control Register 0   |
| 90            | P1 <sup>(1)</sup>    | XXXXXXXX <sup>(2)</sup> | Digital I/O Port Register 1  |
| 8D            | TH1                  | 00000000                | Timer 1 High byte  |
| 8C            | TH0                  | 00000000                | Timer 0 High byte  |
| 8B            | TL1                  | 00000000                | Timer 1 Low byte   |
| 8A            | TL0                  | 00000000                | Timer 0 Low byte   |
| 89            | TMOD                 | 00000000                | Timer 0 and 1 Mode Control Register  |
| 88            | TCON <sup>(1)</sup>  | 00000000                | Timer 0 and 1 Control/External Interrupt Control Register                            |
| 87            | PCON                 | 0XX00000                | Power Control Register   |
| 83            | DPH                  | 00000000                | Data Pointer High byte   |
| 82            | DPL                  | 00000000                | Data Pointer Low byte  |
| 81            | SP                   | 00000111                | Stack Pointer  |
| 80            | P0 <sup>(1)</sup>    | XXXXXXXX <sup>(2)</sup> | Digital I/O Port Register 0  |

#### Notes

1. Bit addressable register.
2. Port reset state determined by the customer.

## Low voltage 8-bit microcontrollers with UART

P80CL31; P80CL51

### 19 INSTRUCTION SET

The P80CLx1 uses a powerful instruction set which permits the expansion of on-chip CPU peripherals and optimizes byte efficiency and execution speed. Assigned opcodes add new high-power operation and permit new addressing modes. The instruction set consists of 49 single-byte, 46 two-byte and 16 three-byte instructions. When using a 12 MHz oscillator, 64 instructions execute in 1  $\mu$ s and 45 instructions execute in 2  $\mu$ s. Multiply and divide instructions execute in 4  $\mu$ s.

For the description of the **Data Addressing modes** and **Hexadecimal opcode cross-reference** see Table 30.

**Table 26** Instruction set description: Arithmetic operations

| MNEMONIC                     | DESCRIPTION                                | BYTES | CYCLES | OPCODE (HEX) |
|------------------------------|--|-------|--------|--------------|
| <b>Arithmetic operations</b> |  |       |        |              |
| ADD A,Rr                     | add register to A                          | 1     | 1      | 2*           |
| ADD A,direct                 | add direct byte to A                       | 2     | 1      | 25           |
| ADD A,@Ri                    | add indirect RAM to A                      | 1     | 1      | 26, 27       |
| ADD A,#data                  | add immediate data to A                    | 2     | 1      | 24           |
| ADDC A,Rr                    | add register to A with carry flag          | 1     | 1      | 3*           |
| ADDC A,direct                | add direct byte to A with carry flag       | 2     | 1      | 35           |
| ADDC A,@Ri                   | add indirect RAM to A with carry flag      | 1     | 1      | 36, 37       |
| ADDC A,#data                 | add immediate data to A with carry flag    | 2     | 1      | 34           |
| SUBB A,Rr                    | subtract register from A with borrow       | 1     | 1      | 9*           |
| SUBB A,direct                | subtract direct byte from A with borrow    | 2     | 1      | 95           |
| SUBB A,@Ri                   | subtract indirect RAM from A with borrow   | 1     | 1      | 96, 97       |
| SUBB A,#data                 | subtract immediate data from A with borrow | 2     | 1      | 94           |
| INC A                        | increment A                                | 1     | 1      | 04           |
| INC Rr                       | increment register                         | 1     | 1      | 0*           |
| INC direct                   | increment direct byte                      | 2     | 1      | 05           |
| INC @Ri                      | increment indirect RAM                     | 1     | 1      | 06, 07       |
| DEC A                        | decrement A                                | 1     | 1      | 14           |
| DEC Rr                       | decrement register                         | 1     | 1      | 1*           |
| DEC direct                   | decrement direct byte                      | 2     | 1      | 15           |
| DEC @Ri                      | decrement indirect RAM                     | 1     | 1      | 16, 17       |
| INC DPTR                     | increment data pointer                     | 1     | 2      | A3           |
| MUL AB                       | multiply A and B                           | 1     | 4      | A4           |
| DIV AB                       | divide A by B                              | 1     | 4      | 84           |
| DA A                         | decimal adjust A                           | 1     | 1      | D4           |

# Low voltage 8-bit microcontrollers with UART

## P80CL31; P80CL51

**Table 27** Instruction set description: Logic operations

| MNEMONIC                |              | DESCRIPTION                                | BYTES | CYCLES | OPCODE (HEX) |
|-------------------------|--------------|--|-------|--------|--------------|
| <b>Logic operations</b> |              |  |       |        |              |
| ANL                     | A,Rr         | AND register to A                          | 1     | 1      | 5*           |
| ANL                     | A,direct     | AND direct byte to A                       | 2     | 1      | 55           |
| ANL                     | A,@Ri        | AND indirect RAM to A                      | 1     | 1      | 56, 57       |
| ANL                     | A,#data      | AND immediate data to A                    | 2     | 1      | 54           |
| ANL                     | direct,A     | AND A to direct byte                       | 2     | 1      | 52           |
| ANL                     | direct,#data | AND immediate data to direct byte          | 3     | 2      | 53           |
| ORL                     | A,Rr         | OR register to A                           | 1     | 1      | 4*           |
| ORL                     | A,direct     | OR direct byte to A                        | 2     | 1      | 45           |
| ORL                     | A,@Ri        | OR indirect RAM to A                       | 1     | 1      | 46, 47       |
| ORL                     | A,#data      | OR immediate data to A                     | 2     | 1      | 44           |
| ORL                     | direct,A     | OR A to direct byte                        | 2     | 1      | 42           |
| ORL                     | direct,#data | OR immediate data to direct byte           | 3     | 2      | 43           |
| XRL                     | A,Rr         | exclusive-OR register to A                 | 1     | 1      | 6*           |
| XRL                     | A,direct     | exclusive-OR direct byte to A              | 2     | 1      | 65           |
| XRL                     | A,@Ri        | exclusive-OR indirect RAM to A             | 1     | 1      | 66, 67       |
| XRL                     | A,#data      | exclusive-OR immediate data to A           | 2     | 1      | 64           |
| XRL                     | direct,A     | exclusive-OR A to direct byte              | 2     | 1      | 62           |
| XRL                     | direct,#data | exclusive-OR immediate data to direct byte | 3     | 2      | 63           |
| CLR                     | A            | clear A                                    | 1     | 1      | E4           |
| CPL                     | A            | complement A                               | 1     | 1      | F4           |
| RL                      | A            | rotate A left                              | 1     | 1      | 23           |
| RLC                     | A            | rotate A left through the carry flag       | 1     | 1      | 33           |
| RR                      | A            | rotate A right                             | 1     | 1      | 03           |
| RRC                     | A            | rotate A right through the carry flag      | 1     | 1      | 13           |
| SWAP                    | A            | swap nibbles within A                      | 1     | 1      | C4           |

# Low voltage 8-bit microcontrollers with UART

## P80CL31; P80CL51

**Table 28** Instruction set description: Data transfer

| MNEMONIC              | DESCRIPTION                                  | BYTES | CYCLES | OPCODE (HEX) |
|-----------------------|--|-------|--------|--------------|
| <b>Data transfer</b>  |  |       |        |              |
| MOV A,Rr              | move register to A                           | 1     | 1      | E*           |
| MOV A,direct (note 1) | move direct byte to A                        | 2     | 1      | E5           |
| MOV A,@Ri             | move indirect RAM to A                       | 1     | 1      | E6, E7       |
| MOV A,#data           | move immediate data to A                     | 2     | 1      | 74           |
| MOV Rr,A              | move A to register                           | 1     | 1      | F*           |
| MOV Rr,direct         | move direct byte to register                 | 2     | 2      | A*           |
| MOV Rr,#data          | move immediate data to register              | 2     | 1      | 7*           |
| MOV direct,A          | move A to direct byte                        | 2     | 1      | F5           |
| MOV direct,Rr         | move register to direct byte                 | 2     | 2      | 8*           |
| MOV direct,direct     | move direct byte to direct                   | 3     | 2      | 85           |
| MOV direct,@Ri        | move indirect RAM to direct byte             | 2     | 2      | 86, 87       |
| MOV direct,#data      | move immediate data to direct byte           | 3     | 2      | 75           |
| MOV @Ri,A             | move A to indirect RAM                       | 1     | 1      | F6, F7       |
| MOV @Ri,direct        | move direct byte to indirect RAM             | 2     | 2      | A6, A7       |
| MOV @Ri,#data         | move immediate data to indirect RAM          | 2     | 1      | 76, 77       |
| MOV DPTR,#data 16     | load data pointer with a 16-bit constant     | 3     | 2      | 90           |
| MOVC A,@A+DPTR        | move code byte relative to DPTR to A         | 1     | 2      | 93           |
| MOVC A,@A+PC          | move code byte relative to PC to A           | 1     | 2      | 83           |
| MOVX A,@Ri            | move external RAM (8-bit address) to A       | 1     | 2      | E2, E3       |
| MOVX A,@DPTR          | move external RAM (16-bit address) to A      | 1     | 2      | E0           |
| MOVX @Ri,A            | move A to external RAM (8-bit address)       | 1     | 2      | F2, F3       |
| MOVX @DPTR,A          | move A to external RAM (16-bit address)      | 1     | 2      | F0           |
| PUSH direct           | push direct byte onto stack                  | 2     | 2      | C0           |
| POP direct            | pop direct byte from stack                   | 2     | 2      | D0           |
| XCH A,Rr              | exchange register with A                     | 1     | 1      | C*           |
| XCH A,direct          | exchange direct byte with A                  | 2     | 1      | C5           |
| XCH A,@Ri             | exchange indirect RAM with A                 | 1     | 1      | C6, C7       |
| XCHD A,@Ri            | exchange LOW-order digit indirect RAM with A | 1     | 1      | D6, D7       |

**Note**

- MOV A,ACC is not permitted.

# Low voltage 8-bit microcontrollers with UART

## P80CL31; P80CL51

**Table 29** Instruction set description: Boolean variable manipulation, Program and machine control

| MNEMONIC                             | DESCRIPTION   | BYTES | CYCLES | OPCODE (HEX) |
|--------------------------------------|---|-------|--------|--------------|
| <b>Boolean variable manipulation</b> |   |       |        |              |
| CLR C                                | clear carry flag                                    | 1     | 1      | C3           |
| CLR bit                              | clear direct bit                                    | 2     | 1      | C2           |
| SETB C                               | set carry flag                                      | 1     | 1      | D3           |
| SETB bit                             | set direct bit                                      | 2     | 1      | D2           |
| CPL C                                | complement carry flag                               | 1     | 1      | B3           |
| CPL bit                              | complement direct bit                               | 2     | 1      | B2           |
| ANL C,bit                            | AND direct bit to carry flag                        | 2     | 2      | 82           |
| ANL C,/bit                           | AND complement of direct bit to carry flag          | 2     | 2      | B0           |
| ORL C,bit                            | OR direct bit to carry flag                         | 2     | 2      | 72           |
| ORL C,/bit                           | OR complement of direct bit to carry flag           | 2     | 2      | A0           |
| MOV C,bit                            | move direct bit to carry flag                       | 2     | 1      | A2           |
| MOV bit,C                            | move carry flag to direct bit                       | 2     | 2      | 92           |
| <b>Program and machine control</b>   |   |       |        |              |
| ACALL addr11                         | absolute subroutine call                            | 2     | 2      | •1           |
| LCALL addr16                         | long subroutine call                                | 3     | 2      | 12           |
| RET                                  | return from subroutine                              | 1     | 2      | 22           |
| RETI                                 | return from interrupt                               | 1     | 2      | 32           |
| AJMP addr11                          | absolute jump                                       | 2     | 2      | ♦1           |
| LJMP addr16                          | long jump   | 3     | 2      | 02           |
| SJMP rel                             | short jump (relative address)                       | 2     | 2      | 80           |
| JMP @A+DPTR                          | jump indirect relative to the DPTR                  | 1     | 2      | 73           |
| JZ rel                               | jump if A is zero                                   | 2     | 2      | 60           |
| JNZ rel                              | jump if A is not zero                               | 2     | 2      | 70           |
| JC rel                               | jump if carry flag is set                           | 2     | 2      | 40           |
| JNC rel                              | jump if carry flag is not set                       | 2     | 2      | 50           |
| JB bit,rel                           | jump if direct bit is set                           | 3     | 2      | 20           |
| JNB bit,rel                          | jump if direct bit is not set                       | 3     | 2      | 30           |
| JBC bit,rel                          | jump if direct bit is set and clear bit             | 3     | 2      | 10           |
| CJNE A,direct,rel                    | compare direct to A and jump if not equal           | 3     | 2      | B5           |
| CJNE A,#data,rel                     | compare immediate to A and jump if not equal        | 3     | 2      | B4           |
| CJNE Rr,#data,rel                    | compare immediate to register and jump if not equal | 3     | 2      | B*           |
| CJNE @Ri,#data,rel                   | compare immediate to indirect and jump if not equal | 3     | 2      | B6, B7       |
| DJNZ Rr,rel                          | decrement register and jump if not zero             | 2     | 2      | D*           |
| DJNZ direct,rel                      | decrement direct and jump if not zero               | 3     | 2      | D5           |
| NOP                                  | no operation  | 1     | 1      | 00           |

## Low voltage 8-bit microcontrollers with UART

P80CL31; P80CL51

**Table 30** Description of the mnemonics in the Instruction set

| MNEMONIC                                  | DESCRIPTION   |
|---|---|
| <b>Data addressing modes</b>              |   |
| Rr  | working register R0-R7  |
| direct                                    | 128 internal RAM locations and any special function register (SFR)  |
| @Ri                                       | indirect internal RAM location addressed by register R0 or R1 of the actual register bank   |
| #data                                     | 8-bit constant included in instruction  |
| #data 16                                  | 16-bit constant included as bytes 2 and 3 of instruction  |
| bit                                       | direct addressed bit in internal RAM or SFR.  |
| addr16                                    | 16-bit destination address. Used by LCALL and LJMP; the branch will be anywhere within the 64 kbytes Program Memory address space                                     |
| addr11                                    | 11-bit destination address. Used by ACALL and AJMP. The branch will be within the same 2 kbytes page of Program Memory as the first byte of the following instruction |
| rel                                       | signed (two's complement) 8-bit offset byte. Used by SJMP and all conditional jumps; range is -128 to +127 bytes relative to first byte of the following instruction  |
| <b>Hexadecimal opcode cross-reference</b> |   |
| *   | 8, 9, A, B, C, D, E, F  |
| •   | 1, 3, 5, 7, 9, B, D, F  |
| ♦   | 0, 2, 4, 6, 8, A, C, E  |



Low voltage 8-bit microcontrollers with  
UART

P80CL31; P80CL51

**Table 31** Instruction map  
 First hexadecimal character of opcode ← Second hexadecimal character of opcode →

| ↓ | 0                   | 1               | 2               | 3                   | 4                   | 5                              | 6                     | 7                    | 8 | 9 | A | B | C | D | E | F |
|---|---------------------|-----------------|-----------------|---------------------|---------------------|--------------------------------|-----------------------|----------------------|---|---|---|---|---|---|---|---|
| 0 | NOP                 | AJMP<br>addr11  | LJMP<br>addr16  | RR<br>A             | INC<br>A            | INC<br>direct                  | INC<br>@Ri            | INC<br>@Ri           | 0 | 1 | 2 | 3 | 4 | 5 | 6 | 7 |
| 1 | JBC<br>bit,rel      | ACALL<br>addr11 | LCALL<br>addr16 | RRC<br>A            | DEC<br>A            | DEC<br>direct                  | DEC<br>@Ri            | DEC<br>@Ri           | 0 | 1 | 2 | 3 | 4 | 5 | 6 | 7 |
| 2 | JB<br>bit,rel       | AJMP<br>addr11  | RET             | RL<br>A             | ADD<br>A,#data      | ADD<br>A,direct                | ADD<br>A,@Ri          | ADD<br>A,@Ri         | 0 | 1 | 2 | 3 | 4 | 5 | 6 | 7 |
| 3 | JNB<br>bit,rel      | ACALL<br>addr11 | RETI            | RLC<br>A            | ADDC<br>A,#data     | ADDC<br>A,direct               | ADDC<br>A,@Ri         | ADDC<br>A,@Ri        | 0 | 1 | 2 | 3 | 4 | 5 | 6 | 7 |
| 4 | JC<br>rel           | AJMP<br>addr11  | ORL<br>direct,A | ORL<br>direct,#data | ORL<br>A,#data      | ORL<br>A,direct                | ORL<br>A,@Ri          | ORL<br>A,@Ri         | 0 | 1 | 2 | 3 | 4 | 5 | 6 | 7 |
| 5 | JNC<br>rel          | ACALL<br>addr11 | ANL<br>direct,A | ANL<br>direct,#data | ANL<br>A,#data      | ANL<br>A,direct                | ANL<br>A,@Ri          | ANL<br>A,@Ri         | 0 | 1 | 2 | 3 | 4 | 5 | 6 | 7 |
| 6 | JZ<br>rel           | AJMP<br>addr11  | XRL<br>direct,A | XRL<br>direct,#data | XRL<br>A,#data      | XRL<br>A,direct                | XRL<br>A,@Ri          | XRL<br>A,@Ri         | 0 | 1 | 2 | 3 | 4 | 5 | 6 | 7 |
| 7 | JNZ<br>rel          | ACALL<br>addr11 | ORL<br>C,bit    | JMP<br>@A+DPTR      | MOV<br>A,#data      | MOV<br>direct,#data            | MOV<br>@Ri,#data      | MOV<br>@Ri,#data     | 0 | 1 | 2 | 3 | 4 | 5 | 6 | 7 |
| 8 | SJMP<br>rel         | AJMP<br>addr11  | ANL<br>C,bit    | MOVC<br>A,@A+PC     | DIV<br>AB           | MOV<br>direct,direct           | MOV<br>direct,@Ri     | MOV<br>direct,Rr     | 0 | 1 | 2 | 3 | 4 | 5 | 6 | 7 |
| 9 | MOV<br>DTPR,#data16 | ACALL<br>addr11 | MOV<br>bit,C    | MOVC<br>A,@A+DPTR   | SUBB<br>A,#data     | SUBB<br>A,direct               | SUBB<br>A,@Ri         | SUBB<br>A,Rr         | 0 | 1 | 2 | 3 | 4 | 5 | 6 | 7 |
| A | ORL<br>C,bit        | AJMP<br>addr11  | MOV<br>bit,C    | INC<br>DPTR         | MUL<br>AB           |                                | MOV<br>@Ri,direct     | MOV<br>Rr,direct     | 0 | 1 | 2 | 3 | 4 | 5 | 6 | 7 |
| B | ANL<br>C,bit        | ACALL<br>addr11 | CPL<br>bit      | CPL<br>C            | CJNE<br>A,#data,rel | CJNE<br>A,direct,rel           | CJNE<br>@Ri,#data,rel | CJNE<br>Rr,#data,rel | 0 | 1 | 2 | 3 | 4 | 5 | 6 | 7 |
| C | PUSH<br>direct      | AJMP<br>addr11  | CLR<br>bit      | CLR<br>C            | SWAP<br>A           | XCH<br>A,direct                | XCH<br>A,@Ri          | XCH<br>A,Rr          | 0 | 1 | 2 | 3 | 4 | 5 | 6 | 7 |
| D | POP<br>direct       | ACALL<br>addr11 | SETB<br>bit     | SETB<br>C           | DA<br>A             | DJNZ<br>direct,rel             | XCHD<br>A,@Ri         | DJNZ<br>Rr,rel       | 0 | 1 | 2 | 3 | 4 | 5 | 6 | 7 |
| E | MOVX<br>A,@DTPR     | AJMP<br>addr11  | MOVX<br>A,@Ri   | MOVX<br>A,@Ri       | CLR<br>A            | MOV<br>A,direct <sup>(1)</sup> | MOV<br>A,@Ri          | MOV<br>A,Rr          | 0 | 1 | 2 | 3 | 4 | 5 | 6 | 7 |
| F | MOVX<br>@DTPR,A     | ACALL<br>addr11 | MOVX<br>@Ri,A   | MOVX<br>@Ri,A       | CPL<br>A            | MOV<br>direct,A                | MOV<br>@Ri,A          | MOV<br>Rr,A          | 0 | 1 | 2 | 3 | 4 | 5 | 6 | 7 |

**Note**

1. MOV A, ACC is not a valid instruction.

# Low voltage 8-bit microcontrollers with UART

## P80CL31; P80CL51

### 20 LIMITING VALUES

In accordance with the Absolute Maximum Rating System (IEC 134).

| SYMBOL    | PARAMETER  | MIN. | MAX.           | UNIT |
|-----------|--|------|----------------|------|
| $V_{DD}$  | supply voltage   | -0.5 | +6.5           | V    |
| $V_I$     | input voltage on any pin with respect to ground ( $V_{SS}$ ) | -0.5 | $V_{DD} + 0.5$ | V    |
| $I_I$     | DC current on any input                                      | -5.0 | +5.0           | mA   |
| $I_O$     | DC current on any output                                     | -5.0 | +5.0           | mA   |
| $P_{tot}$ | total power dissipation                                      | -    | 300            | mW   |
| $T_{stg}$ | storage temperature  | -65  | +150           | °C   |
| $T_{amb}$ | operating ambient temperature                                | -40  | +85            | °C   |
| $T_j$     | operating junction temperature                               | -    | +125           | °C   |

### 21 DC CHARACTERISTICS FOR P80CL31 AND P80CL51

$V_{SS} = 0$  V;  $T_{amb} = -40$  to  $+85$  °C; all voltages with respect to  $V_{SS}$  unless otherwise specified.

| SYMBOL   | PARAMETER  | CONDITIONS   | MIN. | MAX. | UNIT |
|--|--|--|------|------|------|
| $V_{DD}$   | supply voltage<br>operating<br>RAM retention in Power-down<br>mode | $V_{SS} = 0$ V   | 1.8  | 6.0  | V    |
|  |  |  | 1.0  | -    | V    |
| <b>Supply current</b> (note 1, note 2)                   |  |  |      |      |      |
| $I_{DD}$   | operating supply current   | Oscillator 1; $f_{clk} = 32$ kHz; $V_{DD} = 1.8$ V;<br>$T_{amb} = 25$ °C | -    | 50   | μA   |
|  |  | Oscillator 2; $f_{clk} = 3.58$ MHz; $V_{DD} = 3$ V                       | -    | 2.5  | mA   |
|  |  | Oscillator 3; $f_{clk} = 16$ MHz; $V_{DD} = 5$ V                         | -    | 24   | mA   |
|  |  | Oscillator 4; $f_{clk} = 16$ MHz; $V_{DD} = 5$ V                         | -    | 26   | mA   |
| <b>Supply current (Idle mode)</b> (note 2, note 3)       |  |  |      |      |      |
| $I_{DD(idle)}$   | supply current (Idle mode)   | Oscillator 1; $f_{clk} = 32$ kHz; $V_{DD} = 1.8$ V;<br>$T_{amb} = 25$ °C | -    | 25   | μA   |
|  |  | Oscillator 2; $f_{clk} = 3.58$ MHz; $V_{DD} = 3$ V                       | -    | 1.0  | mA   |
|  |  | Oscillator 3; $f_{clk} = 16$ MHz; $V_{DD} = 5$ V                         | -    | 10   | mA   |
|  |  | Oscillator 4; $f_{clk} = 16$ MHz; $V_{DD} = 5$ V                         | -    | 12   | mA   |
| <b>Supply current (Power-down mode)</b> (note 2, note 4) |  |  |      |      |      |
| $I_{DD(pd)}$   | supply current (Power-down mode)                                   | $V_{DD} = 1.8$ V; $T_{amb} = 25$ °C                                      | -    | 10   | μA   |

# Low voltage 8-bit microcontrollers with UART

## P80CL31; P80CL51

| SYMBOL              | PARAMETER  | CONDITIONS  | MIN.        | MAX.        | UNIT             |
|---------------------|--|---|-------------|-------------|------------------|
| <b>Inputs</b>       |  |   |             |             |                  |
| $V_{IL}$            | LOW level input voltage                                    |   | $V_{SS}$    | $0.3V_{DD}$ | V                |
| $V_{IH}$            | HIGH level input voltage                                   |   | $0.7V_{DD}$ | $V_{DD}$    | V                |
| $I_{IL}$            | input current logic 0 (port 1,2,3)                         | $V_{DD} = 5\text{ V}; V_I = 0.4\text{ V}$               | –           | –100        | $\mu\text{A}$    |
|                     |  | $V_{DD} = 2.5\text{ V}; V_I = 0.4\text{ V}$             | –           | –50         | $\mu\text{A}$    |
| $I_{ITL}$           | input current logic 0, HIGH-to-LOW transition (port 1,2,3) | $V_{DD} = 5\text{ V}; V_I = 0.5V_{DD}$                  | –           | –1.0        | mA               |
|                     |  | $V_{DD} = 2.5\text{ V}; V_I = 0.5V_{DD}$                | –           | –500        | $\mu\text{A}$    |
| $I_{LI}$            | input leakage current (port 0, $\overline{EA}$ )           | $V_{SS} < V_I < V_{DD}$                                 | –           | 10          | $\mu\text{A}$    |
| <b>Port outputs</b> |  |   |             |             |                  |
| $I_{OL}$            | LOW level output current                                   | $V_{DD} = 5\text{ V}; V_{OL} = 0.4\text{ V}$            | 1.6         | –           | mA               |
|                     |  | $V_{DD} = 2.5\text{ V}; V_{OL} = 0.4\text{ V}$          | 0.7         | –           | mA               |
| $I_{OH}$            | HIGH level output current (push-pull options)              | $V_{DD} = 5\text{ V}; V_{OH} = V_{DD} - 0.4\text{ V}$   | –1.6        | –           | mA               |
|                     |  | $V_{DD} = 2.5\text{ V}; V_{OH} = V_{DD} - 0.4\text{ V}$ | –0.7        | –           | mA               |
| $R_{RST}$           | RST pull-down resistor                                     |   | 10          | 200         | $\text{k}\Omega$ |

### Notes

- The operating supply current is measured with all output pins disconnected; XTAL 1 driven with  $t_r = t_f = 10\text{ ns}$ ;  $V_{IL} = V_{SS}$ ;  $V_{IH} = V_{DD}$ ; XTAL 2 not connected;  $\overline{EA} = \text{RST} = \text{Port } 0 = V_{DD}$ ; all open drain outputs connected to  $V_{SS}$ .
- Circuits with Power-on-reset option 'OFF' are tested at  $V_{DD(\text{min})} = 1.8\text{ V}$ ; within option 'ON' (typically 1.3 V) they are tested at  $V_{DD(\text{min})} = 2.3\text{ V}$ . Please note, option 'ON' is only available on P80CL51.
- The Idle mode supply current is measured with all output pins disconnected; XTAL 1 driven with  $t_r = t_f = 10\text{ ns}$ ;  $V_{IL} = V_{SS}$ . XTAL 2 not connected;  $\overline{EA} = \text{Port } 0 = V_{DD}$ ;  $\text{RST} = V_{SS}$ ; all open drain outputs connected to  $V_{SS}$ .
- The Power-down current is measured with all output pins disconnected; XTAL 1 not connected;  $\overline{EA} = \text{Port } 0 = V_{DD}$ ;  $\text{RST} = V_{SS}$ ; all open drain outputs connected to  $V_{SS}$ .

# Low voltage 8-bit microcontrollers with UART

## P80CL31; P80CL51

### 22 DC CHARACTERISTICS FOR P80C51

$V_{SS} = 0$  V;  $V_{DD} = 5.0$  V  $\pm 10\%$ ;  $f_{clk} = 3.5$  to 16 MHz;  $T_{amb} = -40$  to  $+85$  °C all voltages with respect to  $V_{SS}$  unless otherwise specified. Note that the Power-on-reset option is 'OFF' and the Oscillator option is 'Oscillator 3'.

| SYMBOL              | PARAMETER   | CONDITIONS                                   | MIN.        | MAX.        | UNIT       |
|---------------------|---|--|-------------|-------------|------------|
| $V_{DD}$            | supply voltage operating                                    | $V_{SS} = 0$ V                               | 4.5         | 5.5         | V          |
|                     | RAM retention in Power-down mode                            |  | 1.0         | –           | V          |
| $I_{DD}$            | operating supply current                                    | $f_{clk} = 16$ MHz; $V_{DD} = 5.0$ V; note 1 | –           | 24          | mA         |
| $I_{DD(idle)}$      | supply current (Idle mode)                                  | $f_{clk} = 16$ MHz; $V_{DD} = 5.0$ V; note 2 | –           | 10          | mA         |
| $I_{DD(pd)}$        | supply current (Power-down mode)                            | $V_{DD} = 5.0$ V; note 3                     | –           | 50          | mA         |
| <b>Inputs</b>       |   |  |             |             |            |
| $V_{IL}$            | LOW level input voltage                                     |  | $V_{SS}$    | $0.3V_{DD}$ | V          |
| $V_{IH}$            | HIGH level input voltage                                    |  | $0.7V_{DD}$ | $V_{DD}$    | V          |
| $I_{IL}$            | input current logic 0 (port 1,2,3)                          | $V_I = 0.4$ V                                | –           | 100         | $\mu$ A    |
| $I_{TL}$            | input current logic 0, HIGH- to-LOW transition (port 1,2,3) | $V_I = 0.5V_{DD}$                            | –           | 1.0         | mA         |
| $I_{LI}$            | input leakage current (port 0, $\overline{EA}$ )            | $V_{SS} < V_I < V_{DD}$                      | –           | 10          | $\mu$ A    |
| <b>Port outputs</b> |   |  |             |             |            |
| $I_{OL}$            | LOW level output current                                    | $V_{OL} = 0.4$ V                             | 1.6         | –           | mA         |
| $I_{OH}$            | HIGH level output current (push-pull options)               | $V_{OH} = V_{DD} - 0.4$ V                    | –1.6        | –           | mA         |
| $R_{RST}$           | RST pull-down resistor                                      |  | 10          | 200         | k $\Omega$ |

#### Notes

- The operating supply current is measured with all output pins disconnected; XTAL 1 driven with  $t_r = t_f = 10$  ns;  $V_{IL} = V_{SS}$ ;  $V_{IH} = V_{DD}$ ; XTAL 2 not connected;  $\overline{EA} = RST = \text{Port 0} = V_{DD}$ ; all open drain outputs connected to  $V_{SS}$ .
- The Idle mode supply current is measured with all output pins disconnected; XTAL 1 driven with  $t_r = t_f = 10$  ns;  $V_{IL} = V_{SS}$ . XTAL 2 not connected;  $\overline{EA} = \text{Port 0} = V_{DD}$ ;  $RST = V_{SS}$ ; all open drain outputs connected to  $V_{SS}$ .
- The Power-down current is measured with all output pins disconnected; XTAL 1 not connected;  $\overline{EA} = \text{Port 0} = V_{DD}$ ;  $RST = V_{SS}$ ; all open drain outputs connected to  $V_{SS}$ .

Low voltage 8-bit microcontrollers with UART

P80CL31; P80CL51

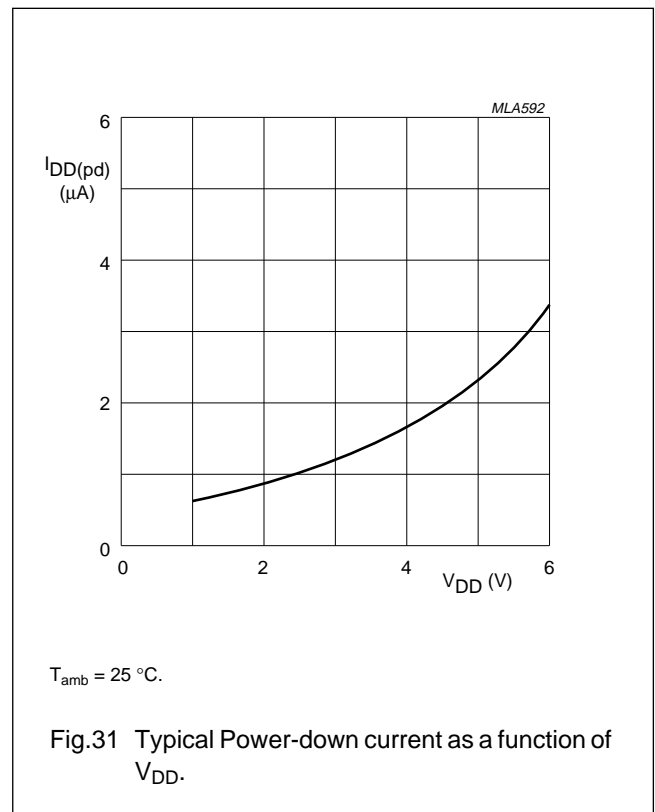
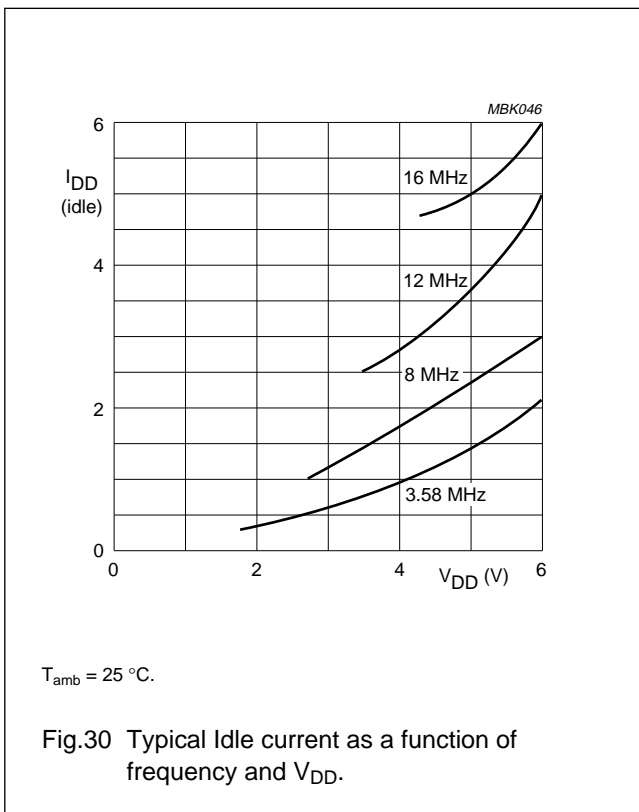
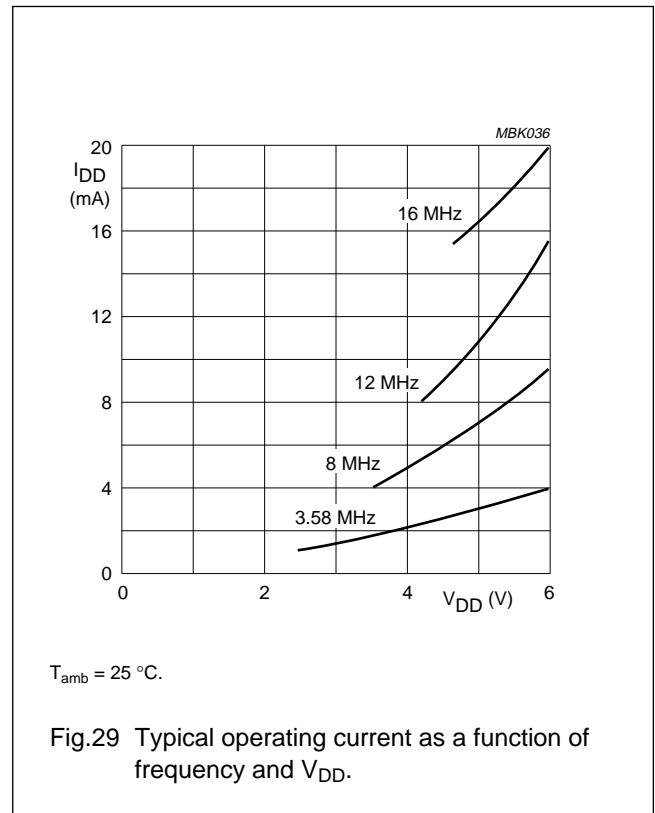
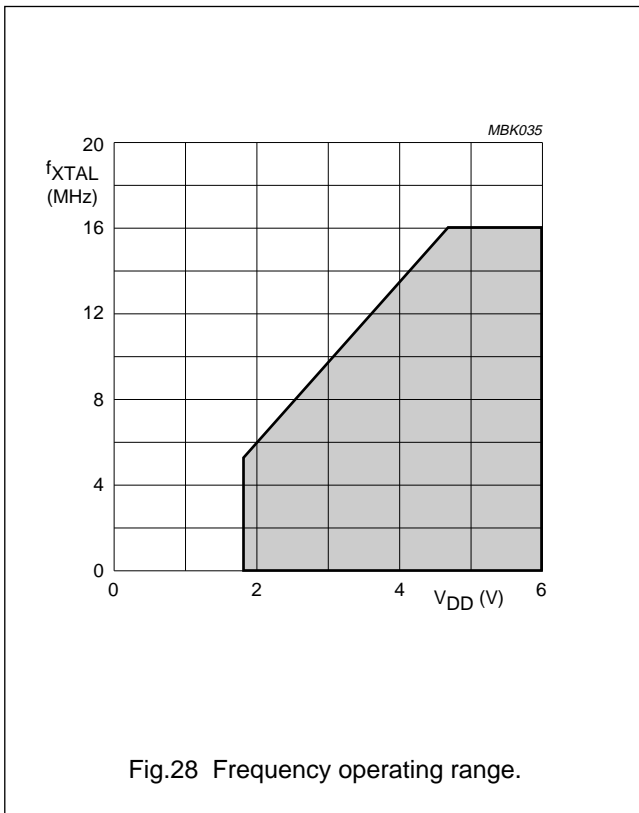

# Low voltage 8-bit microcontrollers with UART

## P80CL31; P80CL51

### 23 AC CHARACTERISTICS

$V_{DD} = 5\text{ V}$ ;  $V_{SS} = 0\text{ V}$ ;  $T_{amb} = -40\text{ to }+85\text{ }^{\circ}\text{C}$ ;  $C_L = 50\text{ pF}$  for Port 0, ALE and  $\overline{\text{PSEN}}$ ;  $C_L = 40\text{ pF}$  for all other outputs unless specified;  $t_{CLK} = 1/f_{CLK}$ .

| SYMBOL                                       | PARAMETER   | $f_{osc} = 12\text{ MHz}$ |      | $f_{osc} = \text{VARIABLE}$ |                  | UNIT |
|--|---|---------------------------|------|-----------------------------|------------------|------|
|  |   | MIN.                      | MAX. | MIN.                        | MAX.             |      |
| <b>Program Memory</b> (Fig.32)               |   |                           |      |                             |                  |      |
| $t_{LHLL}$                                   | ALE pulse width   | 127                       | –    | $2t_{CLK} - 40$             | –                | ns   |
| $t_{AVLL}$                                   | address valid to ALE LOW  | 43                        | –    | $t_{CLK} - 40$              | –                | ns   |
| $t_{LLAX}$                                   | address hold after ALE LOW  | 48                        | –    | $t_{CLK} - 35$              | –                | ns   |
| $t_{LLIV}$                                   | ALE LOW to valid instruction in                                       | –                         | 233  | –                           | $4t_{CLK} - 100$ | ns   |
| $t_{LLPL}$                                   | ALE LOW to $\overline{\text{PSEN}}$ LOW                               | 58                        | –    | $t_{CLK} - 25$              | –                | ns   |
| $t_{PLPH}$                                   | $\overline{\text{PSEN}}$ pulse width                                  | 215                       | –    | $3t_{CLK} - 35$             | –                | ns   |
| $t_{PLIV}$                                   | $\overline{\text{PSEN}}$ LOW to valid instruction in                  | –                         | 125  | –                           | $3t_{CLK} - 125$ | ns   |
| $t_{PXIX}$                                   | input instruction hold after $\overline{\text{PSEN}}$                 | 0                         | –    | 0                           | –                | ns   |
| $t_{PXIZ}$                                   | input instruction float after $\overline{\text{PSEN}}$                | –                         | 63   | –                           | $t_{CLK} - 20$   | ns   |
| $t_{PXAV}$                                   | $\overline{\text{PSEN}}$ to address valid                             | 75                        | –    | $t_{CLK} - 8$               | –                | ns   |
| $t_{AVIV}$                                   | address to valid instruction in                                       | –                         | 302  | –                           | $5t_{CLK} - 115$ | ns   |
| $t_{PLAZ}$                                   | $\overline{\text{PSEN}}$ LOW to address float                         | 12                        | –    | 0                           | –                | ns   |
| <b>External Data Memory</b> (Figs 33 and 34) |   |                           |      |                             |                  |      |
| $t_{RLRH}$                                   | $\overline{\text{RD}}$ pulse width                                    | 400                       | –    | $6t_{CLK} - 100$            | –                | ns   |
| $t_{WLWH}$                                   | $\overline{\text{WR}}$ pulse width                                    | 400                       | –    | $6t_{CLK} - 100$            | –                | ns   |
| $t_{LLAX}$                                   | address hold after ALE LOW  | 48                        | –    | $t_{CLK} - 35$              | –                | ns   |
| $t_{RLDV}$                                   | $\overline{\text{RD}}$ LOW to valid data in                           | –                         | 150  | –                           | $5t_{CLK} - 165$ | ns   |
| $t_{RHDZ}$                                   | data float after $\overline{\text{RD}}$                               | –                         | 97   | –                           | $2t_{CLK} - 70$  | ns   |
| $t_{LLDV}$                                   | ALE LOW to valid data in  | –                         | 517  | –                           | $8t_{CLK} - 150$ | ns   |
| $t_{AVDV}$                                   | address to valid data in  | –                         | 585  | –                           | $9t_{CLK} - 165$ | ns   |
| $t_{LLWL}$                                   | ALE LOW to $\overline{\text{RD}}$ or $\overline{\text{WR}}$ LOW       | 200                       | 300  | $3t_{CLK} - 50$             | $3t_{CLK} + 50$  | ns   |
| $t_{AVWL}$                                   | address valid to $\overline{\text{RD}}$ or $\overline{\text{WR}}$ LOW | 203                       | –    | 4                           | –                | ns   |
| $t_{WHLH}$                                   | $\overline{\text{RD}}$ or $\overline{\text{WR}}$ HIGH to ALE HIGH     | 43                        | 123  | $t_{CLK} - 40$              | $t_{CLK} + 40$   | ns   |
| $t_{QVWX}$                                   | data valid to $\overline{\text{WR}}$ transition                       | 23                        | –    | $t_{CLK} - 60$              | –                | ns   |
| $t_{QVWH}$                                   | data valid time $\overline{\text{WR}}$ HIGH                           | 433                       | –    | $7t_{CLK} - 150$            | –                | ns   |
| $t_{WHQX}$                                   | data hold after $\overline{\text{WR}}$                                | 33                        | –    | $t_{CLK} - 50$              | –                | ns   |
| $t_{RLAZ}$                                   | $\overline{\text{RD}}$ LOW to address float                           | –                         | 12   | –                           | 12               | ns   |

# Low voltage 8-bit microcontrollers with UART

## P80CL31; P80CL51

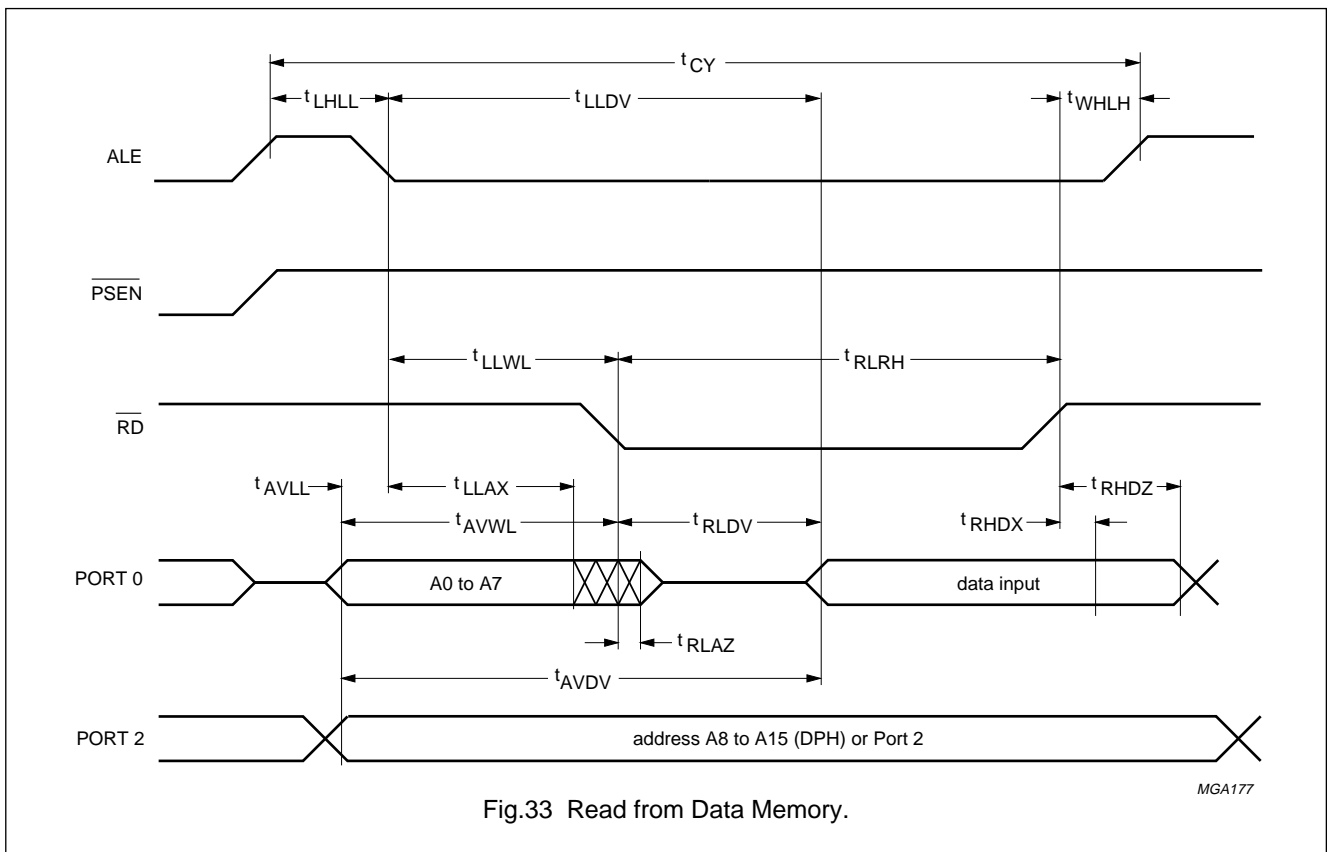
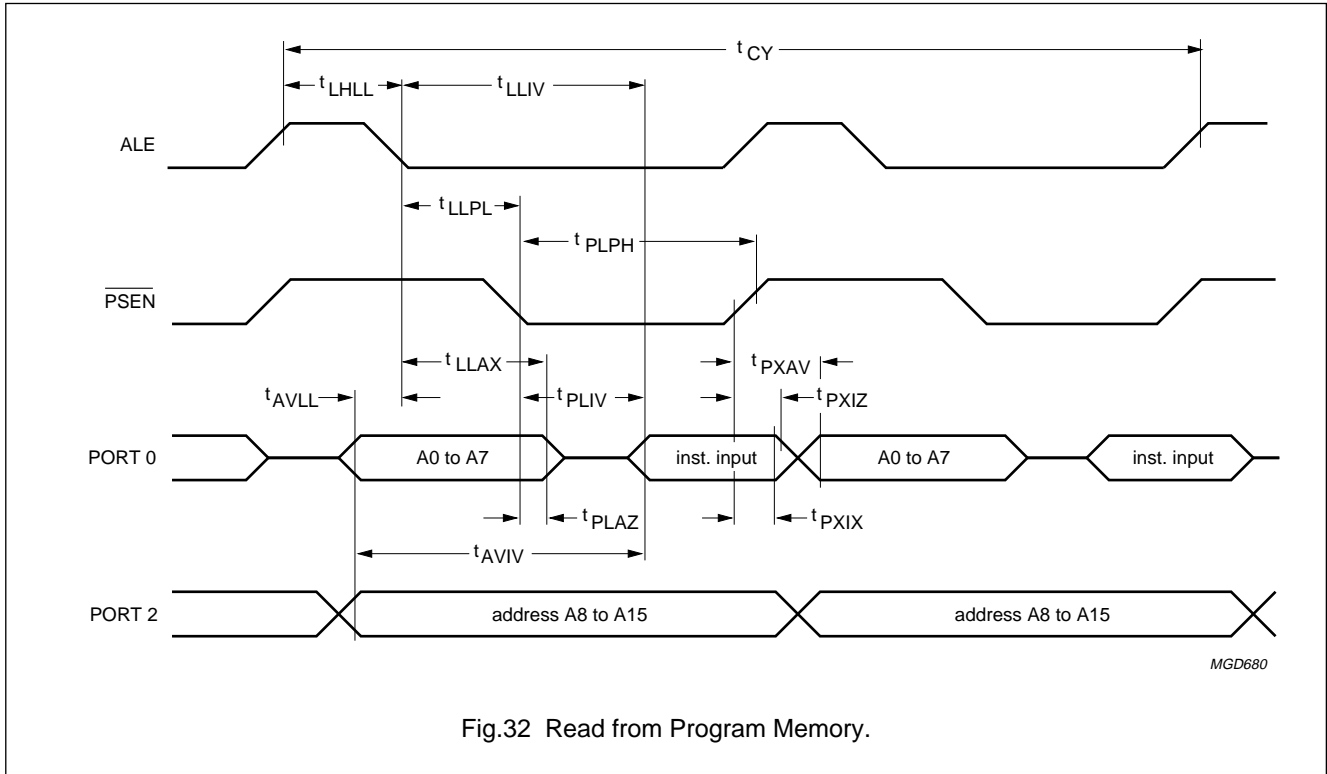

Low voltage 8-bit microcontrollers with  
UART

P80CL31; P80CL51

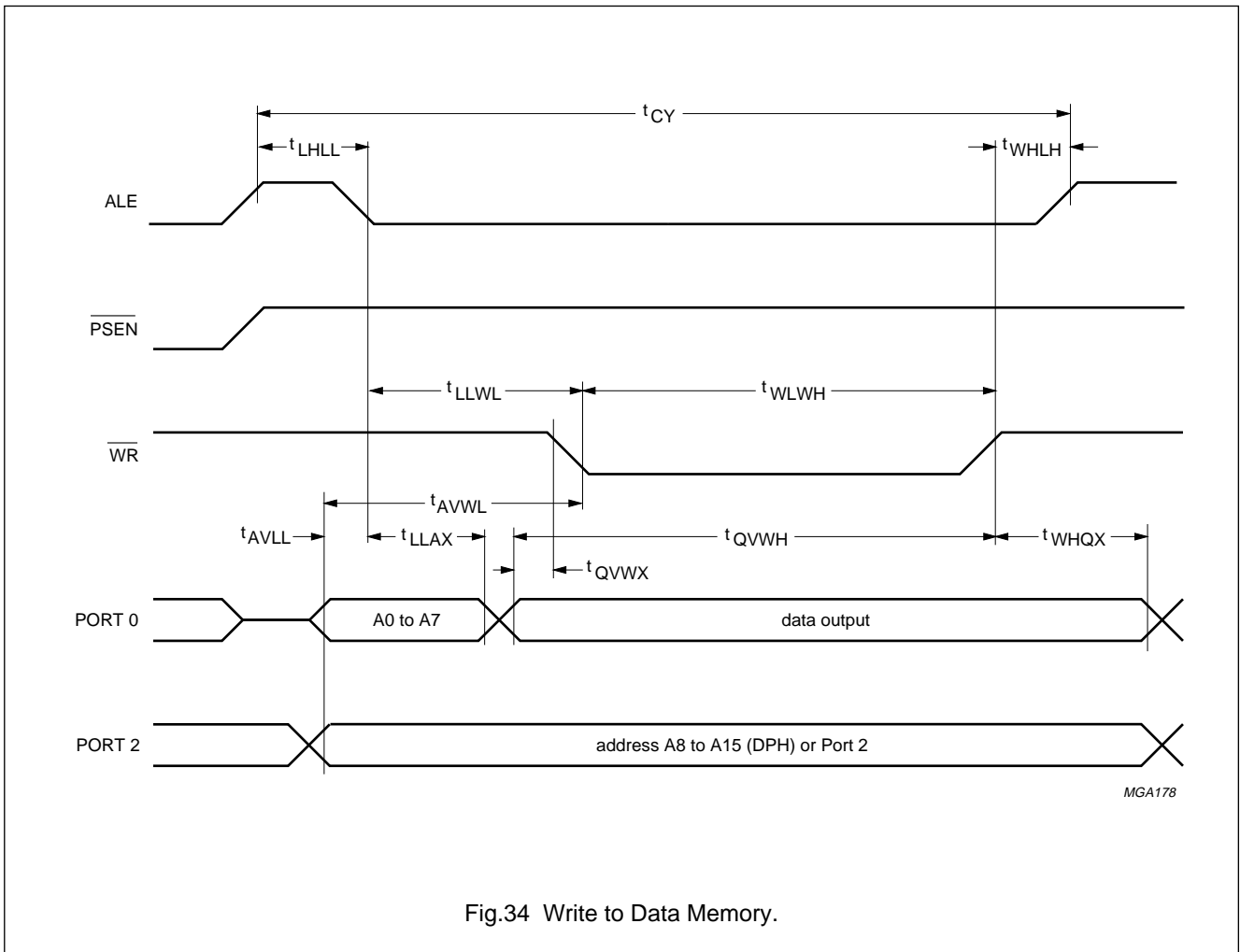



# Low voltage 8-bit microcontrollers with UART

## P80CL31; P80CL51

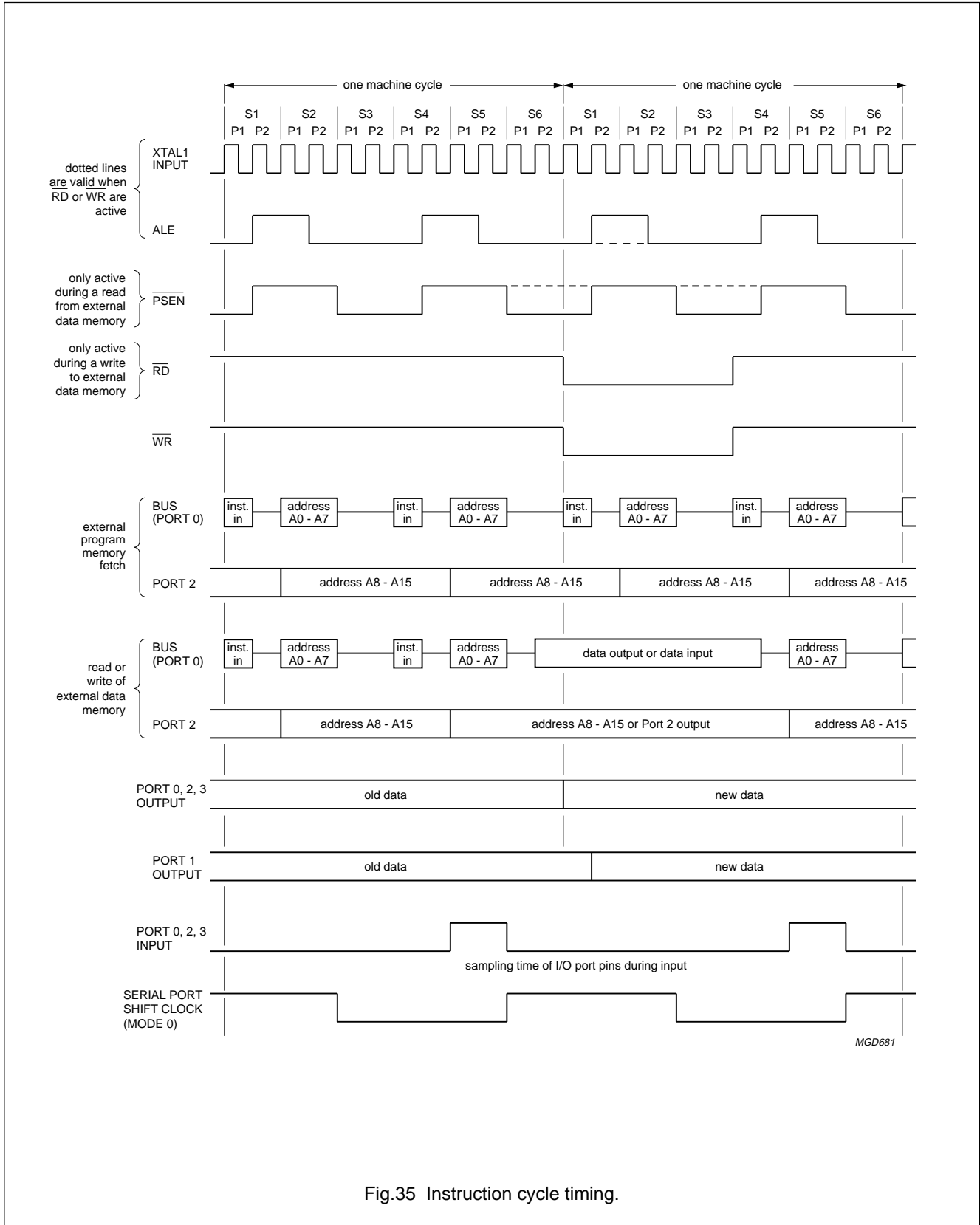

MGD681

# Low voltage 8-bit microcontrollers with UART

P80CL31; P80CL51

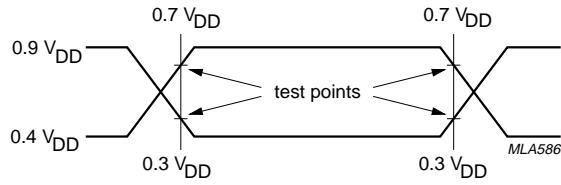

Fig.36 AC testing input waveform.

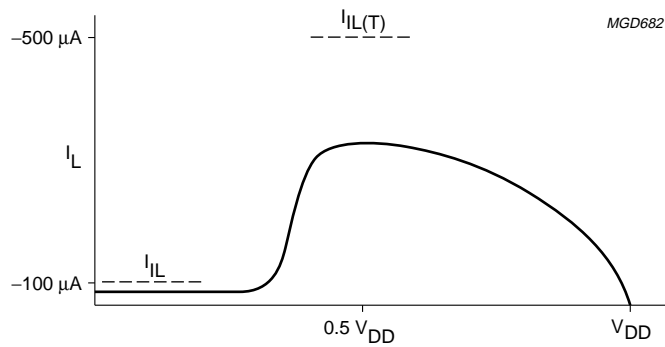

Fig.37 Input current.

## Low voltage 8-bit microcontrollers with UART

## P80CL31; P80CL51

### 24 P85CL000HFZ 'PIGGY-BACK' SPECIFICATION

The differences between the masked version and the piggy-back are described below.

#### 24.1 General description

The P85CL000HFZ is a piggy-back version with 256 bytes of RAM used for emulation of the P80CL51 and the P83CL410 microcontrollers. The P85CL000HFZ is manufactured in an advanced CMOS technology. The instruction set of the P85CL000HFZ is based on that of the 8051. The device has low power consumption and a wide supply voltage range. The P85CL000HFZ has two software selectable modes of reduced activity for further power reduction: Idle and Power-down. For timing and AC/DC characteristics, please refer to the P80CL51 specifications.

### 24.2 Feature differences/additional features with respect to P80CL51

- No internal ROM
- 8-bit CPU, RAM, I/O in a single 40-lead package with DIP pin-out
- Socket for up to 16 kbytes external EPROM
- 256 bytes RAM, expandable externally to 64 kbytes
- I<sup>2</sup>C-bus interface for serial transfer on two lines
- On-chip oscillator: Oscillator 4 option only.

### 24.3 Common specification/feature differences between P85CL000HFZ and P83CL410/P80CL51

| PARAMETER             | P83CL410/P80CL51                     | P85CL000HFZ 'PIGGY-BACK'                            |
|-----------------------|--------------------------------------|---|
| RAM size              | 128                                  | 256   |
| ROM size              | 4K                                   | EPROM size dependent (max. 16K)                     |
| Port options          | 1, 2, 3                              | 1   |
| Oscillator options    | Oscillator 1, 2, 3, 4, RC            | Oscillator 4  |
| Mechanical dimensions | standard dual in-line, small outline | same pin-out as SOT129-1, but larger package size   |
| Current consumption   | I <sub>DD</sub>                      | I <sub>DD</sub> (Oscillator 4) + I <sub>EPROM</sub> |
| Voltage range         | full                                 | full, <b>limited by EPROM</b>                       |
| ESD                   | specification                        | not tested (different package)                      |

# Low voltage 8-bit microcontrollers with UART

## P80CL31; P80CL51

### 25 PACKAGE OUTLINES

DIP40: plastic dual in-line package; 40 leads (600 mil)

SOT129-1

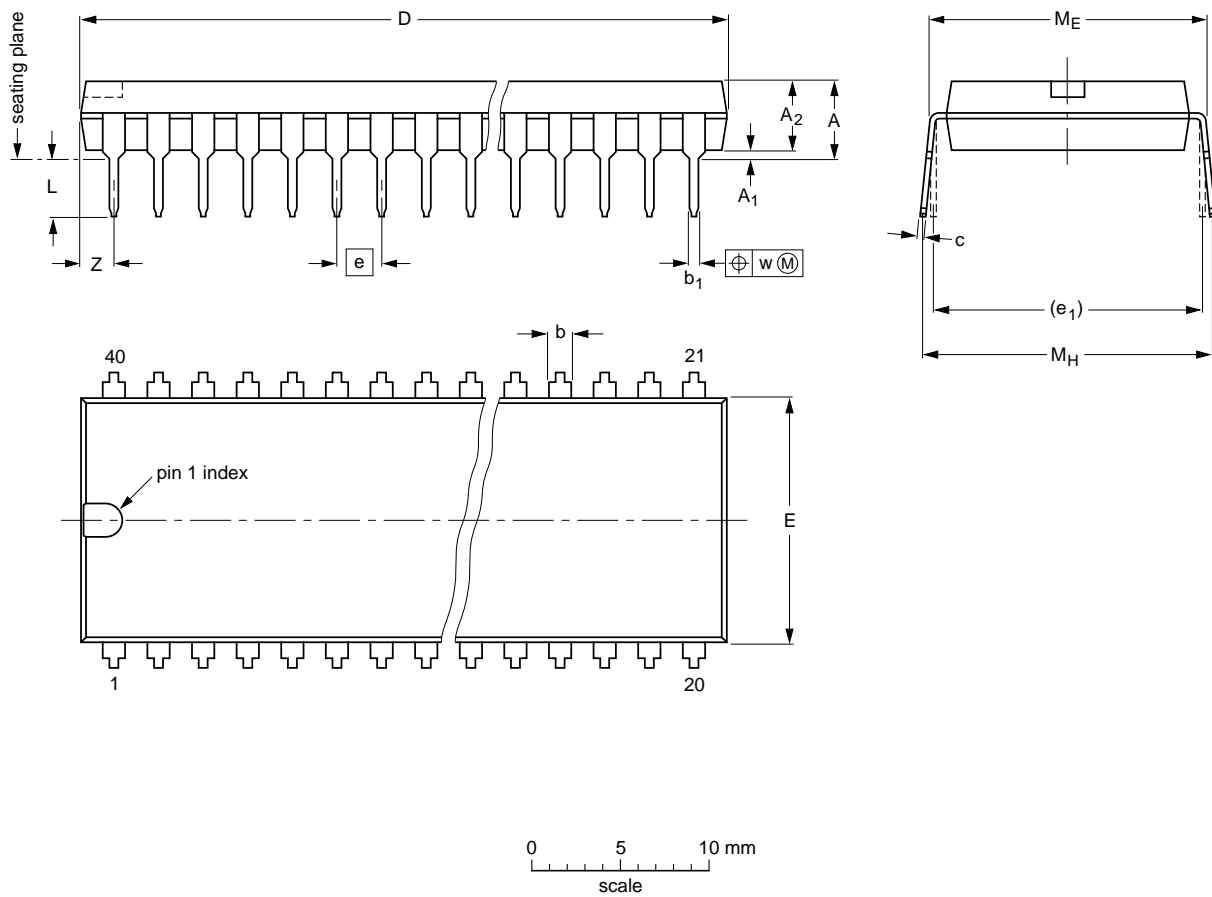

DIMENSIONS (inch dimensions are derived from the original mm dimensions)

| UNIT   | A max. | A <sub>1</sub> min. | A <sub>2</sub> max. | b              | b <sub>1</sub> | c              | D <sup>(1)</sup> | E <sup>(1)</sup> | e    | e <sub>1</sub> | L            | M <sub>E</sub> | M <sub>H</sub> | w     | Z <sup>(1)</sup> max. |
|--------|--------|---------------------|---------------------|----------------|----------------|----------------|------------------|------------------|------|----------------|--------------|----------------|----------------|-------|-----------------------|
| mm     | 4.7    | 0.51                | 4.0                 | 1.70<br>1.14   | 0.53<br>0.38   | 0.36<br>0.23   | 52.50<br>51.50   | 14.1<br>13.7     | 2.54 | 15.24          | 3.60<br>3.05 | 15.80<br>15.24 | 17.42<br>15.90 | 0.254 | 2.25                  |
| inches | 0.19   | 0.020               | 0.16                | 0.067<br>0.045 | 0.021<br>0.015 | 0.014<br>0.009 | 2.067<br>2.028   | 0.56<br>0.54     | 0.10 | 0.60           | 0.14<br>0.12 | 0.62<br>0.60   | 0.69<br>0.63   | 0.01  | 0.089                 |

**Note**

1. Plastic or metal protrusions of 0.25 mm maximum per side are not included.

| OUTLINE VERSION | REFERENCES |          |      |  | EUROPEAN PROJECTION | ISSUE DATE           |
|-----------------|------------|----------|------|--|---------------------|----------------------|
|                 | IEC        | JEDEC    | EIAJ |  |                     |                      |
| SOT129-1        | 051G08     | MO-015AJ |      |  |                     | 92-11-17<br>95-01-14 |

Low voltage 8-bit microcontrollers with UART

P80CL31; P80CL51

VSO40: plastic very small outline package; 40 leads

SOT158-1

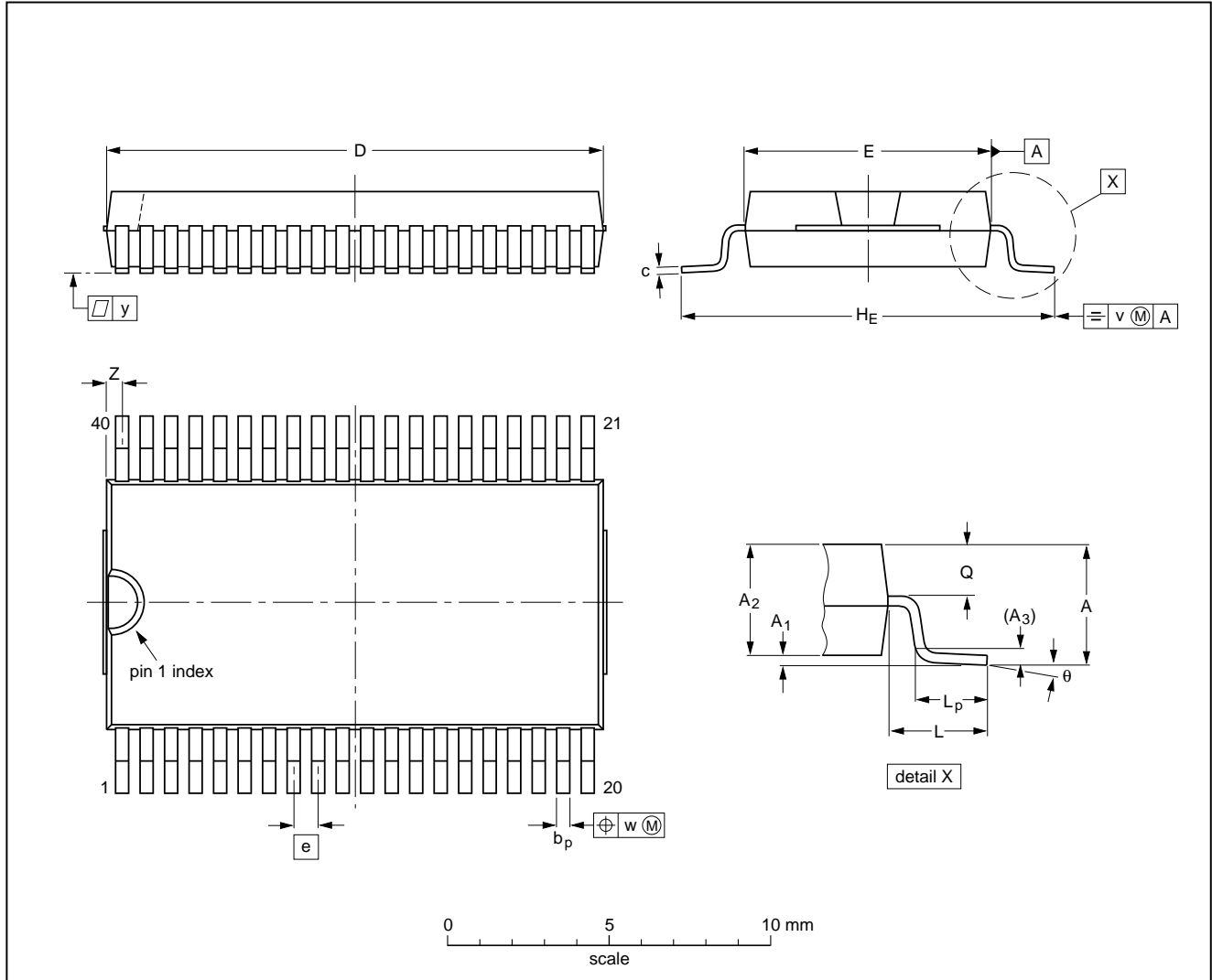

DIMENSIONS (inch dimensions are derived from the original mm dimensions)

| UNIT   | A max. | A <sub>1</sub> | A <sub>2</sub> | A <sub>3</sub> | b <sub>p</sub> | c                | D <sup>(1)</sup> | E <sup>(2)</sup> | e     | H <sub>E</sub> | L     | L <sub>p</sub> | Q              | v     | w     | y     | Z <sup>(1)</sup> | θ        |
|--------|--------|----------------|----------------|----------------|----------------|------------------|------------------|------------------|-------|----------------|-------|----------------|----------------|-------|-------|-------|------------------|----------|
| mm     | 2.70   | 0.3<br>0.1     | 2.45<br>2.25   | 0.25           | 0.42<br>0.30   | 0.22<br>0.14     | 15.6<br>15.2     | 7.6<br>7.5       | 0.762 | 12.3<br>11.8   | 2.25  | 1.7<br>1.5     | 1.15<br>1.05   | 0.2   | 0.1   | 0.1   | 0.6<br>0.3       | 7°<br>0° |
| inches | 0.11   | 0.012<br>0.004 | 0.096<br>0.089 | 0.010          | 0.017<br>0.012 | 0.0087<br>0.0055 | 0.61<br>0.60     | 0.30<br>0.29     | 0.03  | 0.48<br>0.46   | 0.089 | 0.067<br>0.059 | 0.045<br>0.041 | 0.008 | 0.004 | 0.004 | 0.024<br>0.012   |          |

Notes

1. Plastic or metal protrusions of 0.4 mm maximum per side are not included.
2. Plastic interlead protrusions of 0.25 mm maximum per side are not included.

| OUTLINE VERSION | REFERENCES |       |      |  | EUROPEAN PROJECTION | ISSUE DATE           |
|-----------------|------------|-------|------|--|---------------------|----------------------|
|                 | IEC        | JEDEC | EIAJ |  |                     |                      |
| SOT158-1        |            |       |      |  |                     | 92-11-17<br>95-01-24 |

Low voltage 8-bit microcontrollers with  
UART

P80CL31; P80CL51

QFP44: plastic quad flat package; 44 leads (lead length 1.3 mm); body 10 x 10 x 1.75 mm

SOT307-2

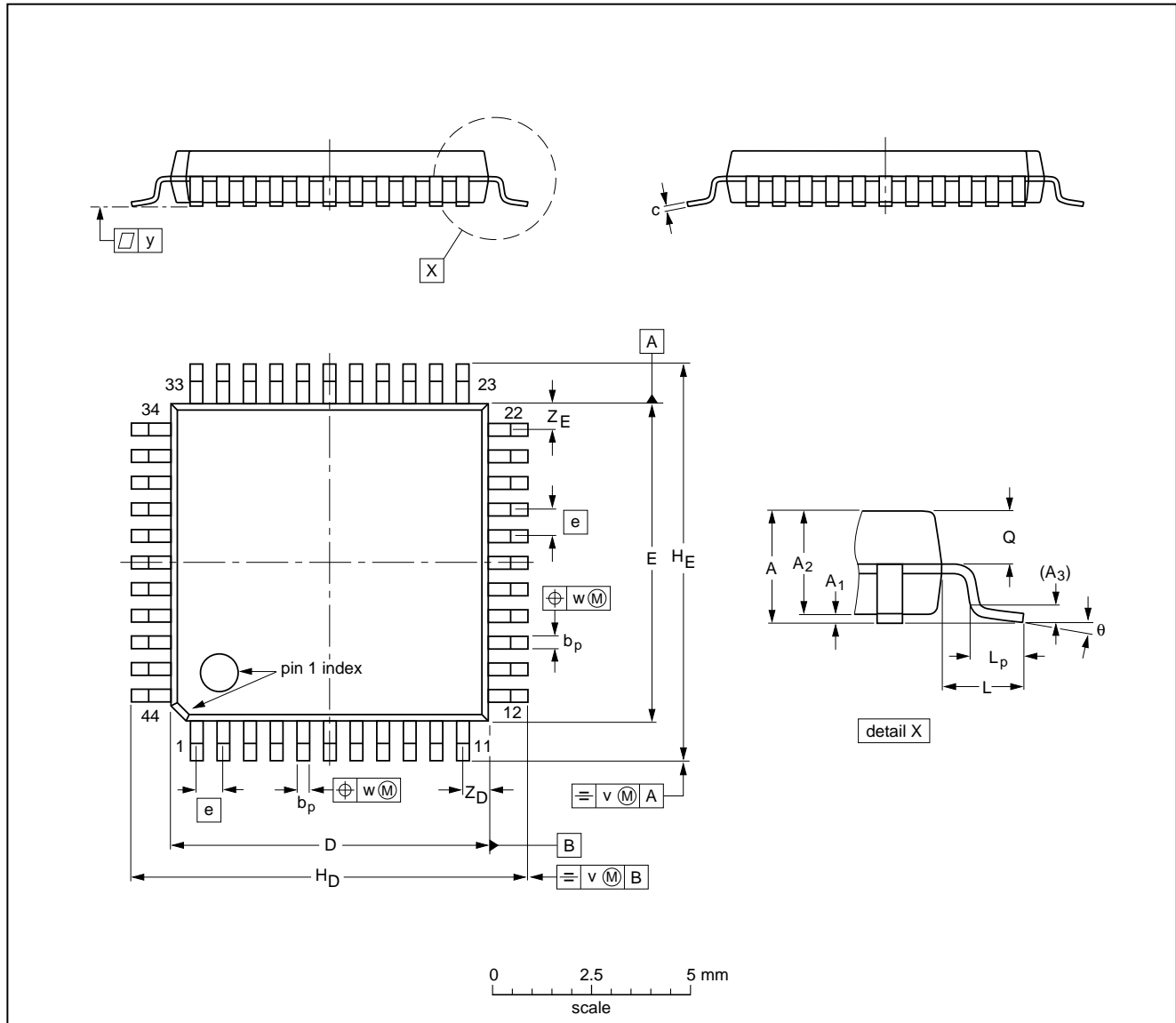

**DIMENSIONS (mm are the original dimensions)**

| UNIT | A<br>max. | A <sub>1</sub> | A <sub>2</sub> | A <sub>3</sub> | b <sub>p</sub> | c            | D <sup>(1)</sup> | E <sup>(1)</sup> | e   | H <sub>D</sub> | H <sub>E</sub> | L   | L <sub>p</sub> | Q            | v    | w    | y   | Z <sub>D</sub> <sup>(1)</sup> | Z <sub>E</sub> <sup>(1)</sup> | θ         |
|------|-----------|----------------|----------------|----------------|----------------|--------------|------------------|------------------|-----|----------------|----------------|-----|----------------|--------------|------|------|-----|-------------------------------|-------------------------------|-----------|
| mm   | 2.10      | 0.25<br>0.05   | 1.85<br>1.65   | 0.25           | 0.40<br>0.20   | 0.25<br>0.14 | 10.1<br>9.9      | 10.1<br>9.9      | 0.8 | 12.9<br>12.3   | 12.9<br>12.3   | 1.3 | 0.95<br>0.55   | 0.85<br>0.75 | 0.15 | 0.15 | 0.1 | 1.2<br>0.8                    | 1.2<br>0.8                    | 10°<br>0° |

**Note**

1. Plastic or metal protrusions of 0.25 mm maximum per side are not included.

| OUTLINE<br>VERSION | REFERENCES |       |      | EUROPEAN<br>PROJECTION | ISSUE DATE           |
|--------------------|------------|-------|------|------------------------|----------------------|
|                    | IEC        | JEDEC | EIAJ |                        |                      |
| SOT307-2           |            |       |      |                        | 92-11-17<br>95-02-04 |

## Low voltage 8-bit microcontrollers with UART

## P80CL31; P80CL51

### 26 SOLDERING

#### 26.1 Introduction

There is no soldering method that is ideal for all IC packages. Wave soldering is often preferred when through-hole and surface mounted components are mixed on one printed-circuit board. However, wave soldering is not always suitable for surface mounted ICs, or for printed-circuits with high population densities. In these situations reflow soldering is often used.

This text gives a very brief insight to a complex technology. A more in-depth account of soldering ICs can be found in our "IC Package Databook" (order code 9398 652 90011).

#### 26.2 DIP

##### 26.2.1 SOLDERING BY DIPPING OR BY WAVE

The maximum permissible temperature of the solder is 260 °C; solder at this temperature must not be in contact with the joint for more than 5 seconds. The total contact time of successive solder waves must not exceed 5 seconds.

The device may be mounted up to the seating plane, but the temperature of the plastic body must not exceed the specified maximum storage temperature ( $T_{stg\ max}$ ). If the printed-circuit board has been pre-heated, forced cooling may be necessary immediately after soldering to keep the temperature within the permissible limit.

##### 26.2.2 REPAIRING SOLDERED JOINTS

Apply a low voltage soldering iron (less than 24 V) to the lead(s) of the package, below the seating plane or not more than 2 mm above it. If the temperature of the soldering iron bit is less than 300 °C it may remain in contact for up to 10 seconds. If the bit temperature is between 300 and 400 °C, contact may be up to 5 seconds.

#### 26.3 QFP and VSO

##### 26.3.1 REFLOW SOLDERING

Reflow soldering techniques are suitable for all QFP and VSO packages.

The choice of heating method may be influenced by larger plastic QFP packages (44 leads, or more). If infrared or vapour phase heating is used and the large packages are not absolutely dry (less than 0.1% moisture content by weight), vaporization of the small amount of moisture in them can cause cracking of the plastic body. For more information, refer to the Drypack chapter in our "Quality Reference Manual" (order code 9397 750 00192).

Reflow soldering requires solder paste (a suspension of fine solder particles, flux and binding agent) to be applied to the printed-circuit board by screen printing, stencilling or pressure-syringe dispensing before package placement.

Several techniques exist for reflowing; for example, thermal conduction by heated belt. Dwell times vary between 50 and 300 seconds depending on heating method. Typical reflow temperatures range from 215 to 250 °C.

Preheating is necessary to dry the paste and evaporate the binding agent. Preheating duration: 45 minutes at 45 °C.

##### 26.3.2 WAVE SOLDERING

###### 26.3.2.1 QFP

Wave soldering is **not** recommended for QFP packages. This is because of the likelihood of solder bridging due to closely-spaced leads and the possibility of incomplete solder penetration in multi-lead devices.

**If wave soldering cannot be avoided, the following conditions must be observed:**

- A double-wave (a turbulent wave with high upward pressure followed by a smooth laminar wave) soldering technique should be used.
- The footprint must be at an angle of 45° to the board direction and must incorporate solder thieves downstream and at the side corners.

**Even with these conditions, do not consider wave soldering the following packages: QFP52 (SOT379-1), QFP100 (SOT317-1), QFP100 (SOT317-2), QFP100 (SOT382-1) or QFP160 (SOT322-1).**

###### 26.3.2.2 VSO

Wave soldering techniques can be used for all VSO packages if the following conditions are observed:

- A double-wave (a turbulent wave with high upward pressure followed by a smooth laminar wave) soldering technique should be used.
- The longitudinal axis of the package footprint must be parallel to the solder flow.
- The package footprint must incorporate solder thieves at the downstream end.

## Low voltage 8-bit microcontrollers with UART

P80CL31; P80CL51

### 26.3.2.3 Method (QFP and VSO)

During placement and before soldering, the package must be fixed with a droplet of adhesive. The adhesive can be applied by screen printing, pin transfer or syringe dispensing. The package can be soldered after the adhesive is cured.

Maximum permissible solder temperature is 260 °C, and maximum duration of package immersion in solder is 10 seconds, if cooled to less than 150 °C within 6 seconds. Typical dwell time is 4 seconds at 250 °C.

A mildly-activated flux will eliminate the need for removal of corrosive residues in most applications.

### 26.3.3 REPAIRING SOLDERED JOINTS

Fix the component by first soldering two diagonally-opposite end leads. Use only a low voltage soldering iron (less than 24 V) applied to the flat part of the lead. Contact time must be limited to 10 seconds at up to 300 °C. When using a dedicated tool, all other leads can be soldered in one operation within 2 to 5 seconds between 270 and 320 °C.

## 27 DEFINITIONS

|   |   |
|---|---|
| <b>Data sheet status</b>  |   |
| Objective specification   | This data sheet contains target or goal specifications for product development.       |
| Preliminary specification   | This data sheet contains preliminary data; supplementary data may be published later. |
| Product specification   | This data sheet contains final product specifications.                                |
| <b>Limiting values</b>  |   |
| Limiting values given are in accordance with the Absolute Maximum Rating System (IEC 134). Stress above one or more of the limiting values may cause permanent damage to the device. These are stress ratings only and operation of the device at these or at any other conditions above those given in the Characteristics sections of the specification is not implied. Exposure to limiting values for extended periods may affect device reliability. |   |
| <b>Application information</b>  |   |
| Where application information is given, it is advisory and does not form part of the specification.   |   |

## 28 LIFE SUPPORT APPLICATIONS

These products are not designed for use in life support appliances, devices, or systems where malfunction of these products can reasonably be expected to result in personal injury. Philips customers using or selling these products for use in such applications do so at their own risk and agree to fully indemnify Philips for any damages resulting from such improper use or sale.



---

Low voltage 8-bit microcontrollers with  
UART

P80CL31; P80CL51

---

**NOTES**

---

Low voltage 8-bit microcontrollers with  
UART

P80CL31; P80CL51

---

**NOTES**

---

Low voltage 8-bit microcontrollers with  
UART

P80CL31; P80CL51

---

**NOTES**

# Philips Semiconductors – a worldwide company

**Argentina:** see South America

**Australia:** 34 Waterloo Road, NORTH RYDE, NSW 2113,  
Tel. +61 2 9805 4455, Fax. +61 2 9805 4466

**Austria:** Computerstr. 6, A-1101 WIEN, P.O. Box 213,  
Tel. +43 1 60 101, Fax. +43 1 60 101 1210

**Belarus:** Hotel Minsk Business Center, Bld. 3, r. 1211, Volodarski Str. 6,  
220050 MINSK, Tel. +375 172 200 733, Fax. +375 172 200 773

**Belgium:** see The Netherlands

**Brazil:** see South America

**Bulgaria:** Philips Bulgaria Ltd., Energoproject, 15th floor,  
51 James Bourchier Blvd., 1407 SOFIA,  
Tel. +359 2 689 211, Fax. +359 2 689 102

**Canada:** PHILIPS SEMICONDUCTORS/COMPONENTS,  
Tel. +1 800 234 7381

**China/Hong Kong:** 501 Hong Kong Industrial Technology Centre,  
72 Tat Chee Avenue, Kowloon Tong, HONG KONG,  
Tel. +852 2319 7888, Fax. +852 2319 7700

**Colombia:** see South America

**Czech Republic:** see Austria

**Denmark:** Prags Boulevard 80, PB 1919, DK-2300 COPENHAGEN S,  
Tel. +45 32 88 2636, Fax. +45 31 57 0044

**Finland:** Sinikalliontie 3, FIN-02630 ESPOO,  
Tel. +358 9 615800, Fax. +358 9 61580920

**France:** 4 Rue du Port-aux-Vins, BP317, 92156 SURESNES Cedex,  
Tel. +33 1 40 99 6161, Fax. +33 1 40 99 6427

**Germany:** Hammerbrookstraße 69, D-20097 HAMBURG,  
Tel. +49 40 23 53 60, Fax. +49 40 23 536 300

**Greece:** No. 15, 25th March Street, GR 17778 TAVROS/ATHENS,  
Tel. +30 1 4894 339/239, Fax. +30 1 4814 240

**Hungary:** see Austria

**India:** Philips INDIA Ltd, Shivsagar Estate, A Block, Dr. Annie Besant Rd.  
Worli, MUMBAI 400 018, Tel. +91 22 4938 541, Fax. +91 22 4938 722

**Indonesia:** see Singapore

**Ireland:** Newstead, Clonskeagh, DUBLIN 14,  
Tel. +353 1 7640 000, Fax. +353 1 7640 200

**Israel:** RAPAC Electronics, 7 Kehilat Saloniki St, PO Box 18053,  
TEL AVIV 61180, Tel. +972 3 645 0444, Fax. +972 3 649 1007

**Italy:** PHILIPS SEMICONDUCTORS, Piazza IV Novembre 3,  
20124 MILANO, Tel. +39 2 6752 2531, Fax. +39 2 6752 2557

**Japan:** Philips Bldg 13-37, Kohnan 2-chome, Minato-ku, TOKYO 108,  
Tel. +81 3 3740 5130, Fax. +81 3 3740 5077

**Korea:** Philips House, 260-199 Itaewon-dong, Yongsan-ku, SEOUL,  
Tel. +82 2 709 1412, Fax. +82 2 709 1415

**Malaysia:** No. 76 Jalan Universiti, 46200 PETALING JAYA, SELANGOR,  
Tel. +60 3 750 5214, Fax. +60 3 757 4880

**Mexico:** 5900 Gateway East, Suite 200, EL PASO, TEXAS 79905,  
Tel. +9-5 800 234 7381

**Middle East:** see Italy

**Netherlands:** Postbus 90050, 5600 PB EINDHOVEN, Bldg. VB,  
Tel. +31 40 27 82785, Fax. +31 40 27 88399

**New Zealand:** 2 Wagener Place, C.P.O. Box 1041, AUCKLAND,  
Tel. +64 9 849 4160, Fax. +64 9 849 7811

**Norway:** Box 1, Manglerud 0612, OSLO,  
Tel. +47 22 74 8000, Fax. +47 22 74 8341

**Philippines:** Philips Semiconductors Philippines Inc.,  
106 Valero St. Salcedo Village, P.O. Box 2108 MCC, MAKATI,  
Metro MANILA, Tel. +63 2 816 6380, Fax. +63 2 817 3474

**Poland:** Ul. Lukiska 10, PL 04-123 WARSZAWA,  
Tel. +48 22 612 2831, Fax. +48 22 612 2327

**Portugal:** see Spain

**Romania:** see Italy

**Russia:** Philips Russia, Ul. Usatcheva 35A, 119048 MOSCOW,  
Tel. +7 095 755 6918, Fax. +7 095 755 6919

**Singapore:** Lorong 1, Toa Payoh, SINGAPORE 1231,  
Tel. +65 350 2538, Fax. +65 251 6500

**Slovakia:** see Austria

**Slovenia:** see Italy

**South Africa:** S.A. PHILIPS Pty Ltd., 195-215 Main Road Martindale,  
2092 JOHANNESBURG, P.O. Box 7430 Johannesburg 2000,  
Tel. +27 11 470 5911, Fax. +27 11 470 5494

**South America:** Rua do Rocio 220, 5th floor, Suite 51,  
04552-903 São Paulo, SÃO PAULO - SP, Brazil,  
Tel. +55 11 821 2333, Fax. +55 11 829 1849

**Spain:** Balmes 22, 08007 BARCELONA,  
Tel. +34 3 301 6312, Fax. +34 3 301 4107

**Sweden:** Kottbygatan 7, Akalla, S-16485 STOCKHOLM,  
Tel. +46 8 632 2000, Fax. +46 8 632 2745

**Switzerland:** Allmendstrasse 140, CH-8027 ZÜRICH,  
Tel. +41 1 488 2686, Fax. +41 1 481 7730

**Taiwan:** Philips Semiconductors, 6F, No. 96, Chien Kuo N. Rd., Sec. 1,  
TAIPEI, Taiwan Tel. +886 2 2134 2865, Fax. +886 2 2134 2874

**Thailand:** PHILIPS ELECTRONICS (THAILAND) Ltd.,  
209/2 Sanpavuth-Bangna Road Prakanong, BANGKOK 10260,  
Tel. +66 2 745 4090, Fax. +66 2 398 0793

**Turkey:** Talatpasa Cad. No. 5, 80640 GÜLTEPE/ISTANBUL,  
Tel. +90 212 279 2770, Fax. +90 212 282 6707

**Ukraine:** PHILIPS UKRAINE, 4 Patrice Lumumba str., Building B, Floor 7,  
252042 KIEV, Tel. +380 44 264 2776, Fax. +380 44 268 0461

**United Kingdom:** Philips Semiconductors Ltd., 276 Bath Road, Hayes,  
MIDDLESEX UB3 5BX, Tel. +44 181 730 5000, Fax. +44 181 754 8421

**United States:** 811 East Arques Avenue, SUNNYVALE, CA 94088-3409,  
Tel. +1 800 234 7381

**Uruguay:** see South America

**Vietnam:** see Singapore

**Yugoslavia:** PHILIPS, Trg N. Pasica 5/v, 11000 BEOGRAD,  
Tel. +381 11 625 344, Fax. +381 11 635 777

**For all other countries apply to:** Philips Semiconductors, Marketing & Sales Communications,  
Building BE-p, P.O. Box 218, 5600 MD EINDHOVEN, The Netherlands, Fax. +31 40 27 24825

**Internet:** <http://www.semiconductors.philips.com>

© Philips Electronics N.V. 1997

SCA54

All rights are reserved. Reproduction in whole or in part is prohibited without the prior written consent of the copyright owner.

The information presented in this document does not form part of any quotation or contract, is believed to be accurate and reliable and may be changed without notice. No liability will be accepted by the publisher for any consequence of its use. Publication thereof does not convey nor imply any license under patent- or other industrial or intellectual property rights.

Printed in The Netherlands

457047/1200/03/pp68

Date of release: 1997 Apr 15

Document order number: 9397 750 01512

*Let's make things better.*

**Philips  
Semiconductors**



**PHILIPS**