

3A ADJUSTABLE-TYPE LOW DROPOUT VOLTAGE REGULATOR WITH OUTPUT ON/OFF CONTROL FUNCTION. [Low Quiescent Current Type]

FEATURES

- 3.0A Output Low Drop Voltage Regulator.
- Built in ON/OFF Control Terminal. (Active High)
- Built in Over Current, Over Heat Protection Function, ASO Protection Functions.
- Low Quiescent Current (Output OFF mode) : 0.5 μ A(Typ.)
- Adjustable Output Voltage Type : $V_{OUT}=1.5\sim 7V$
- Low Voltage Operation : $V_{opr}(min.)=2.35V$.

LINE UP

ITEM	OUTPUT VOLTAGE (Typ.)	PACKAGE
KIA378R000FP	Adjustable (1.5~7.0)	D ² PAK-5
KIA278R000PI	Adjustable (1.5~7.0)	TO-220IS-4

MAXIMUM RATINGS (Ta=25 °C)

CHARACTERISTIC		SYMBOL	RATING	UNIT
Input Voltage		V_{IN}	7	V
ON/OFF Control Voltage		V_C	7	V
Output Adjustment Terminal Voltage		V_{ADJ}	5	V
Output Current		I_{OUT}	3.0	A
Power Dissipation 1 (No Heatsink)	FP	P_{D1}	2.0	W
	PI		1.5	
Power Dissipation 2 (Infinite Heatsink)	FP	P_{D2}	35	W
	PI		15	
Junction Temperature		T_j	150	°C
Operating Temperature		T_{opr}	-20 ~ 80	°C
Storage Temperature		T_{stg}	-30 ~ 125	°C

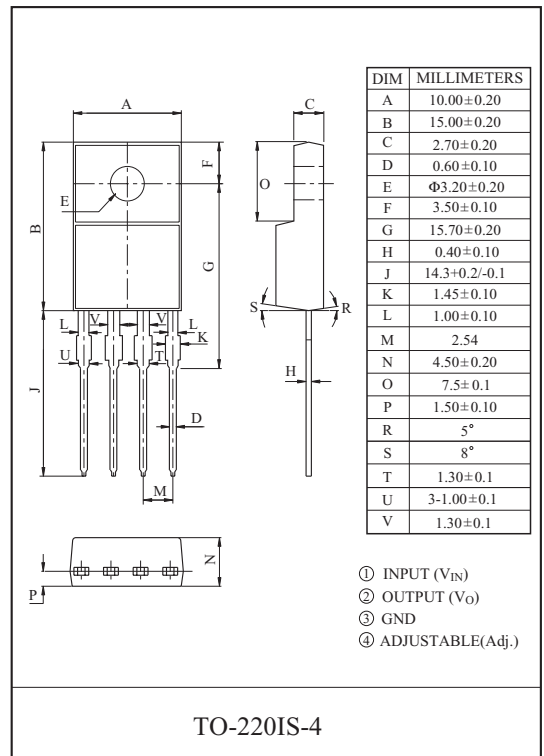
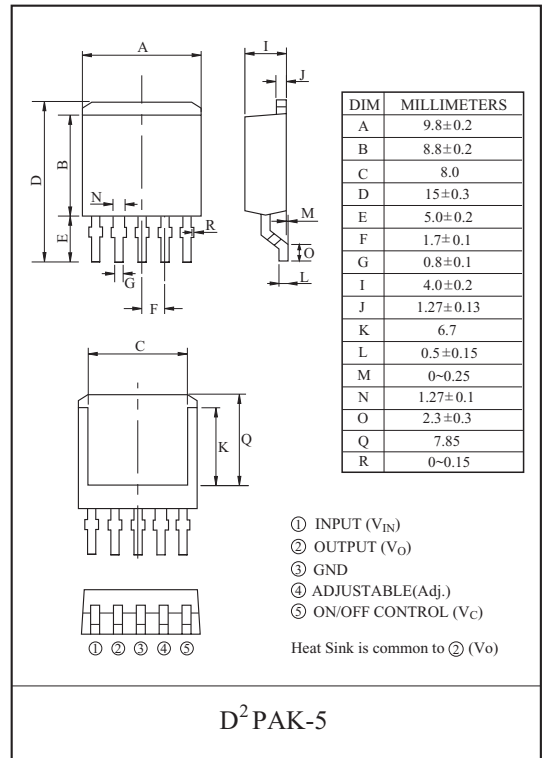

KIA378R000FP/PI

ELECTRICAL CHARACTERISTICS (Unless otherwise specified, $V_{IN}=5V$, $V_O=3.3V$, $I_O=1.5A$, $R_1=1k\Omega$, $T_j=25^\circ C$)

CHARACTERISTIC	SYMBOL	CONDITIONS	MIN.	TYP.	MAX.	UNIT
Input Voltage	V_{IN}	-	2.35	-	7	V
Output Voltage	V_{OUT}	-	1.5	-	7	V
Reference Voltage	V_{ref}	-	1.22	1.25	1.28	V
Load Regulation	Reg Load	$I_O=5mA\sim 3A$	-	0.2	2.0	%
Line Regulation	Reg Line	$V_{IN}=V_O+1$ to 6V, $I_O=5mA$	-	0.2	1.0	%
Temperature Coefficient of Output Voltage	$T_C V_O$	$T_j=0\sim 125^\circ C$, $I_O=5mA$	-	± 1.0	± 20	%
Ripple Rejection	$R \cdot R$	$I_{OUT}=0.3A$, $f=120Hz$, $V_{ripple}=0.5V_{rms}$, $V_{IN}=5V$, $V_O=3V$	45	60	-	dB
Output ON state for control Voltage	$V_{C(ON)}$	-	2.0	-	-	V
Output ON state for control Current	$I_{C(ON)}$	$V_C=2.7V$	-	-	200	μA
Output OFF state for control Voltage	$V_{C(OFF)}$	$I_O=0$	-	-	0.8	V
Output OFF state for control Current	$I_{C(OFF)}$	$V_C=0.4V$	-	-	2.0	μA
Quiescent Current	I_Q	$I_O=0$	-	1	2	mA
Quiescent Current (OFF Mode)	$I_{Q(OFF)}$	$V_C=0.4V$	-	0.1	5	μA
Dropout Voltage	V_D	$I_O=3A$	-	-	0.8	V

BLOCK DIAGRAM

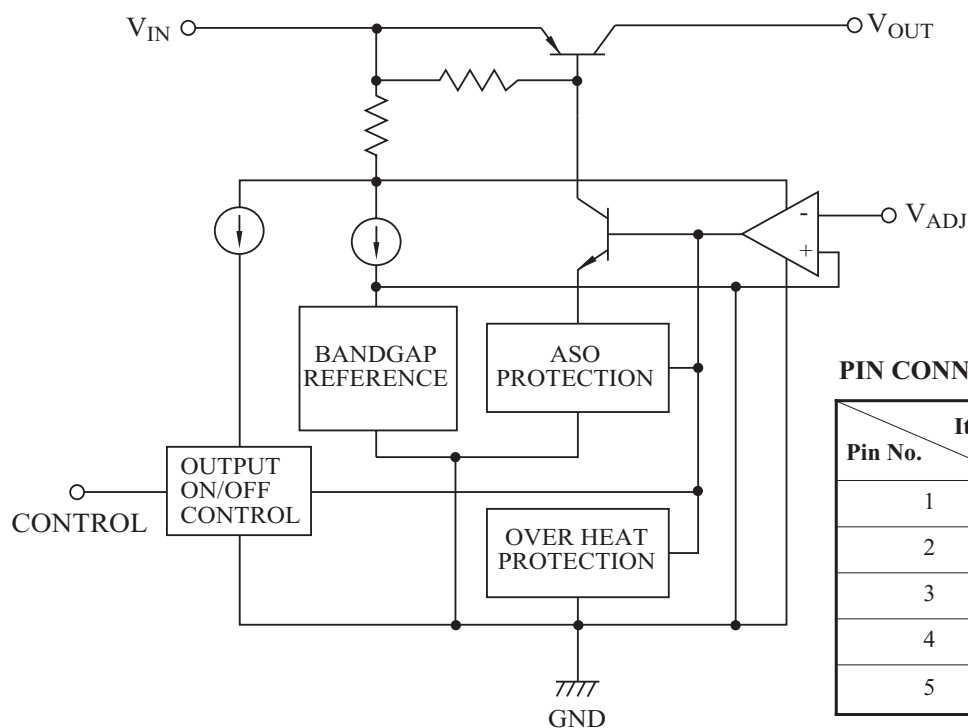

PIN CONNECTION

Item Pin No.	KIA378R000PI (TO-220IS-4)	KIA378R000FP (D ² PAK-5)
1	V_{IN}	V_{IN}
2	V_{OUT}	V_{OUT}
3	GND	GND
4	Adj	Adj
5	-	V_C

KIA378R000FP/PI

Fig. 1 Test Circuit

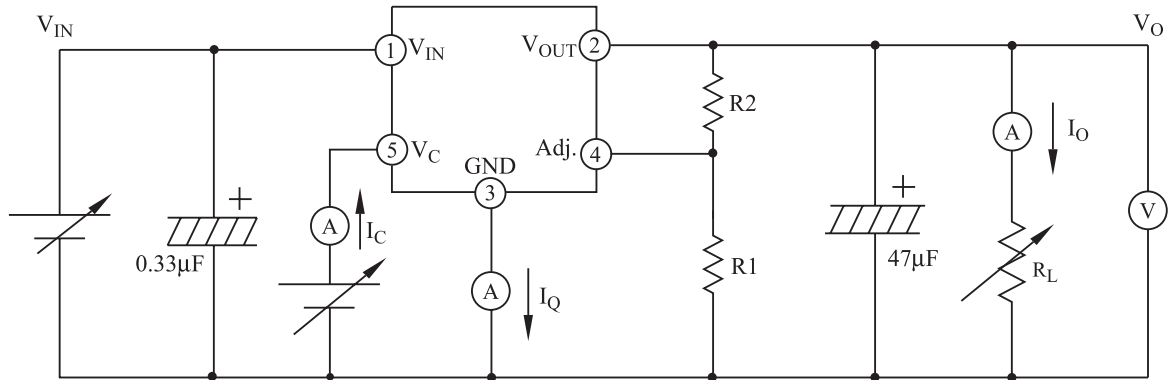

- (1) $V_{OUT} = V_{ref} \times (1 + R_2/R_1)$, ($R_1 = 1k \Omega$, $V_{ref} = 1.25V$)
 (2) ⑤ Pin (V_C) Terminal is only for KIA378R000FP (D²PAK-5)

Fig. 2 Ripple Rejection Circuit

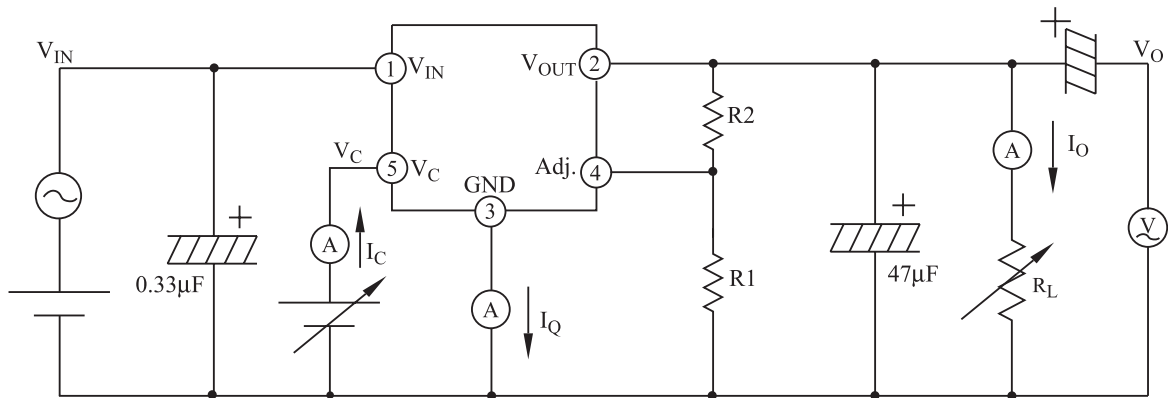
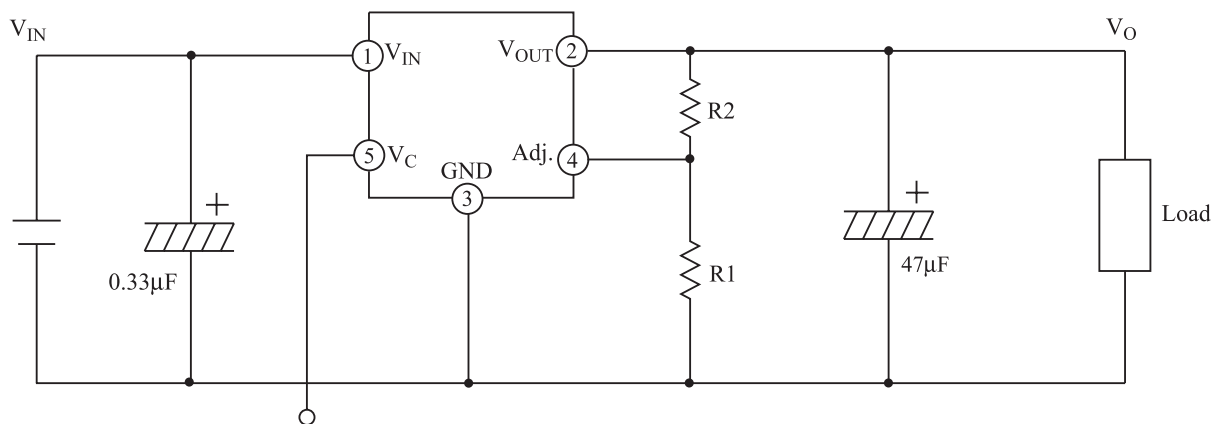

Fig. 3 Application Circuit for Standard



- (1) ON/OFF Signal [High : Output ON]
 [Low/Open : Output OFF]
 (2) $V_{OUT} = V_{ref} \times (1 + R_1/R_2)$, ($R_1 = 1k \Omega$, $V_{ref} = 1.25V$)
 (3) ⑤ Pin (V_C) Terminal is only for KIA378R000FP (D²PAK-5)

Fig. 4 $I_O - V_O$

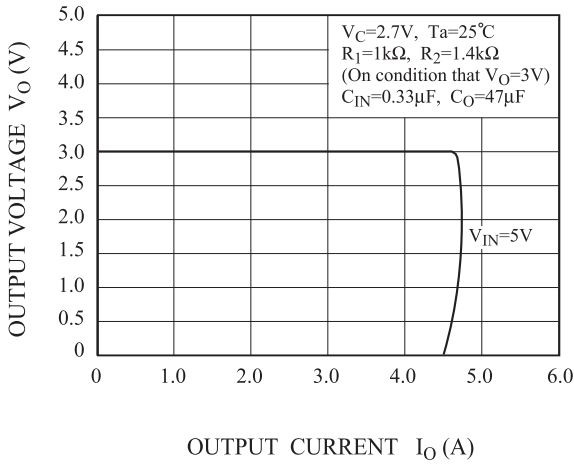

Fig. 5 $T_a - \Delta V_{ref}$

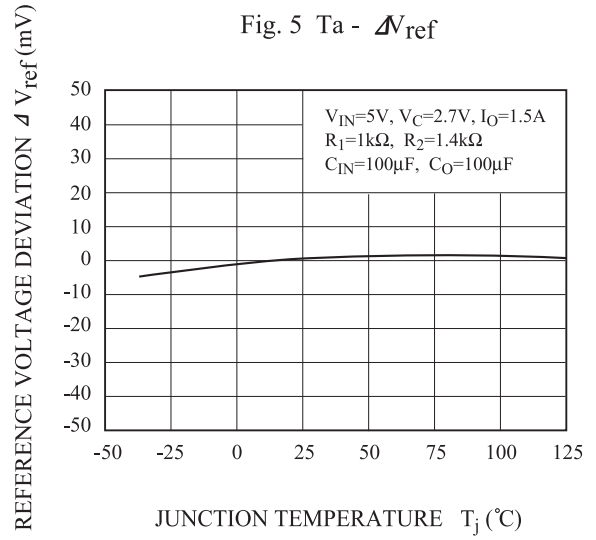

Fig. 6 $V_{IN} - V_O$

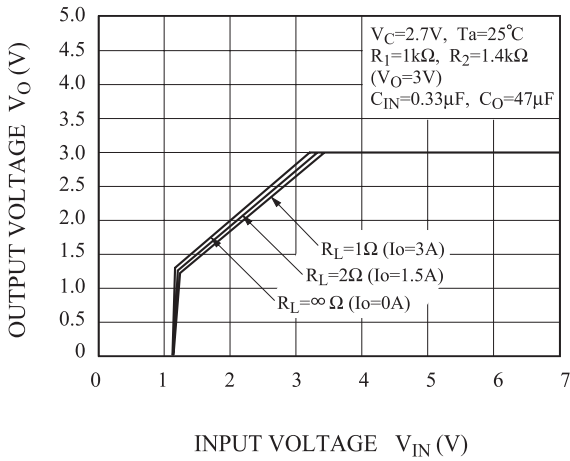

Fig. 7 $V_{IN} - I_Q$

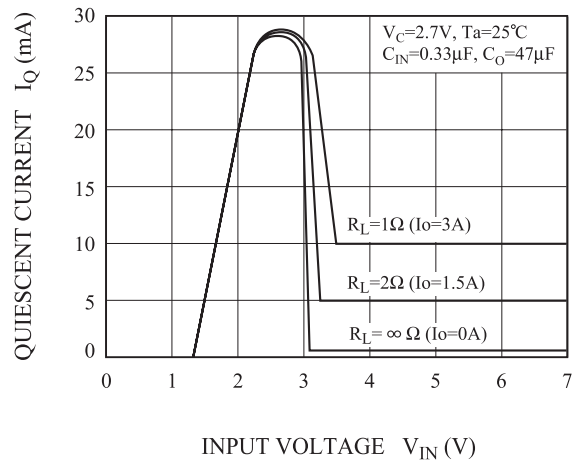

Fig. 8 $T_j - V_D$

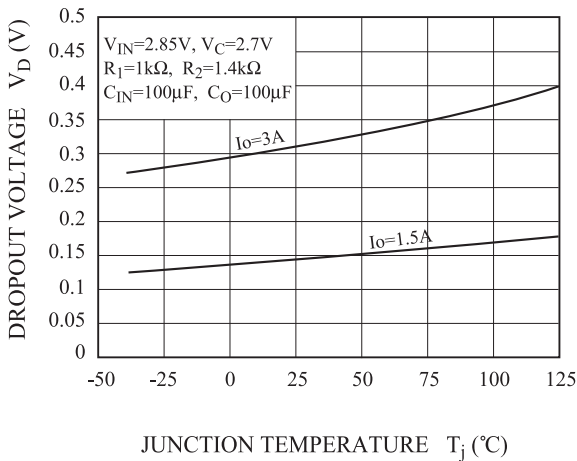

Fig. 9 $T_j - I_Q$

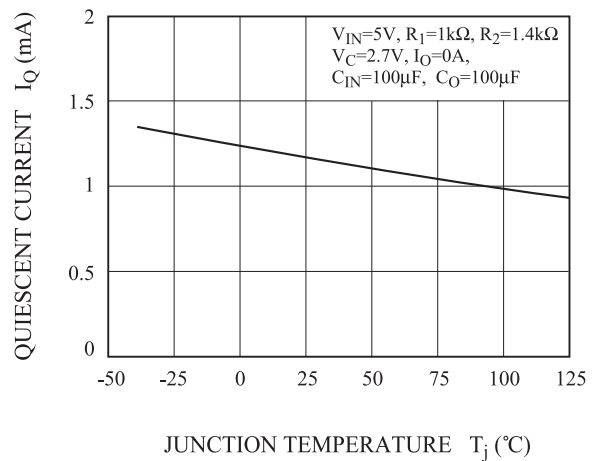

Fig.10 f_{IN} - R·R

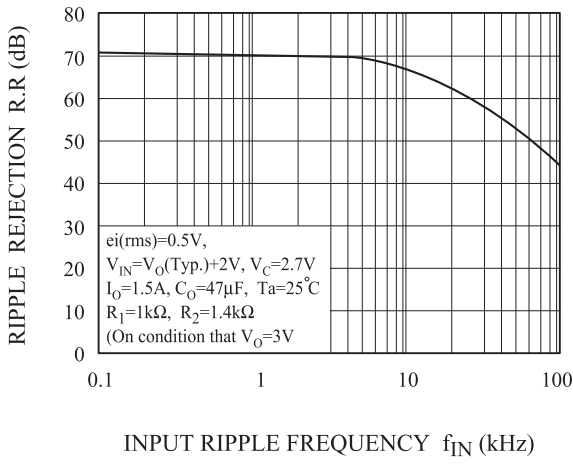

Fig. 11 V_{IN} - R·R

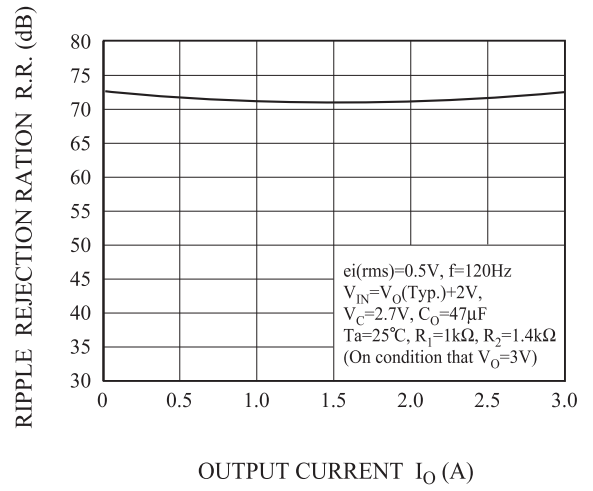

Fig. 12 P_D - T_a (FP-Type D^2 PAK-5)

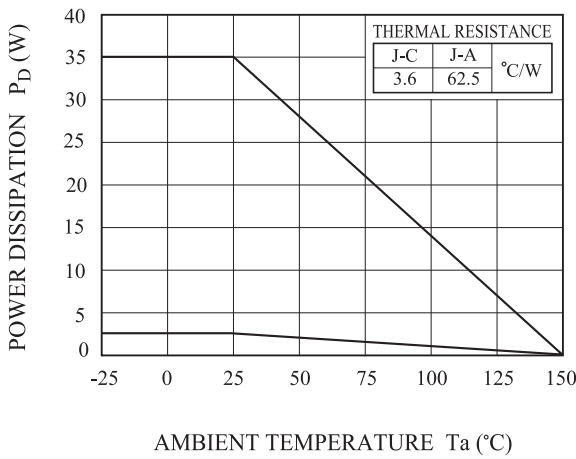

Fig. 13 P_D - T_a (PI-Type : To-220IS-4)

