

<h1>THYRISTOR</h1>	<h1>30A Avg 800 Volts</h1>	<h1>PGH308</h1>
--------------------	----------------------------	-----------------

回路図 CIRCUIT

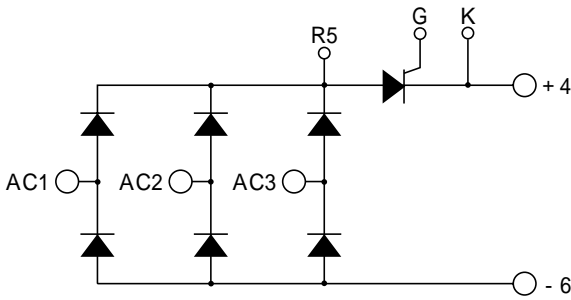

外形寸法図 OUTLINE DRAWING (単位 Dimension : mm)

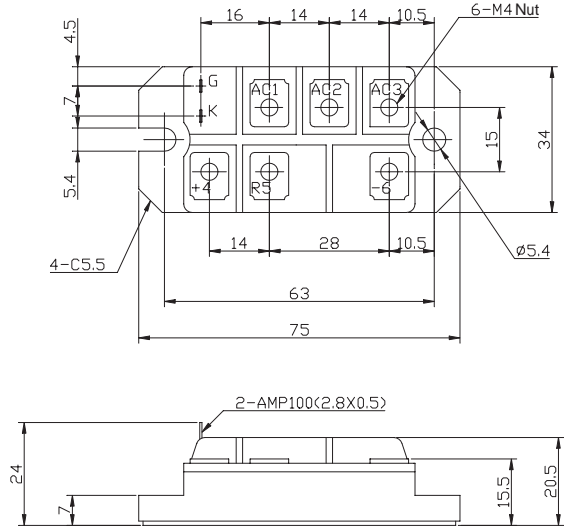

総合定格・特性 Part of Diode Bridge & Thyristor
 最大定格 Maximum Ratings

項目 Parameter	記号 Symbol	条件 Conditions	定格値 Max. Rated Value	単位 Unit	
平均出力電流 Average Rectified Output Current	$I_{O(AV)}$	三相全波整流 $T_c = 80$ 3-Phase Full Wave Rectified	30	A	
動作接合温度範囲 Operating Junction Temperature Range	T_{jw}		- 40 ~ + 125		
保存温度範囲 Storage Temperature Range	T_{stg}		- 40 ~ + 125		
絶縁耐圧 Isolation Voltage	V_{iso}	端子 - ベース間, AC 1 分間 Terminal to Base, AC 1 min.	2000	V	
締付トルク Mounting Torque	ベース部 Mounting	サーマルコンパウンド塗布 Greased	M5	2.4 ~ 2.8	N・m
	主端子部 Terminal		M4	1.2 ~ 1.6	N・m
	ゲート端子部 Gate Terminal				N・m

熱特性 Thermal Characteristics

項目 Parameter	記号 Symbol	条件 Conditions	特性値(最大) Maximum Value	単位 Unit
接触熱抵抗 Thermal Resistance	$R_{th(c-f)}$	ケース - フィン間(トータル), サーマルコンパウンド塗布 Case to Fin, Total, Greased	0.1	/W

質量 Approximate Weight...約80g

ダイオードブリッジ部 (6素子) Part of Diode Bridge (6 dies)

最大定格 Maximum Ratings

項目 Parameter	記号 Symbol	耐圧クラス Grade	単位 Unit
		PGH308	
くり返しピーク逆電圧 *1 Repetitive Peak Reverse Voltage	V_{RRM}	800	V
非くり返しピーク逆電圧 *1 Non Repetitive Peak Reverse Voltage	V_{RSM}	900	V

項目 Parameter	記号 Symbol	条件 Conditions	定格値 Max. Rated Value	単位 Unit
サージ順電流 *1 Surge Forward Current	I_{FSM}	50Hz正弦半波, 1 サイクル, 非くり返し Half Sine Wave, 1Pulse, Non-Repetitive	400	A
電流二乗時間積 *1 $I^2 t$	$I^2 t$	2 ~ 10ms	800	A ² s
許容周波数 Allowable Operating Frequency	f		400	Hz

*1 : 1 アーム当りの値 Value Per 1 Arm.

サイリスタモジュール

電気的特性 Electrical Characteristics

項目 Parameter	記号 Symbol	条件 Conditions	特性値(最大) Maximum Value	単位 Unit
ピーク逆電流 Peak Reverse Current	*1 I _{RM}	T _j =125 , V _{RM} =V _{RRM}	5	mA
ピーク順電圧 Peak Forward Voltage	*1 V _{FM}	T _j = 25 , I _{FM} =30A	1.06	V
熱抵抗 Thermal Resistance	R _{th(j-c)}	接合部 - ケース間 (トータル) Junction to Case, Total	0.70	/W

*1: 1アーム当りの値 Value Per 1 Arm.

サイリスタ部 (1素子) Part of Thyristor (1 die)

最大定格 Maximum Ratings

項目 Parameter	記号 Symbol	耐圧クラス Grade		単位 Unit
		PGH308		
くり返しピークオフ電圧 Repetitive Peak Off-State Voltage	V _{DRM}	800		V
非くり返しピークオフ電圧 Non Repetitive Peak Off-State Voltage	V _{DSM}	900		V
くり返しピーク逆電圧 Repetitive Peak Reverse Voltage	V _{RRM}	800		V
非くり返しピーク逆電圧 Non Repetitive Peak Reverse Voltage	V _{RSM}	900		V

項目 Parameter	記号 Symbol	条件 Conditions	定格値 Max. Rated Value	単位 Unit
サージオン電流 Surge On-State Current	I _{TSM}	50Hz正弦半波, 1サイクル, 非くり返し Half Sine Wave, 1Pulse, Non-Repetitive	400	A
電流二乗時間積 I Squared t	I ² t	2 ~ 10ms	800	A ² s
臨界オン電流上昇率 Critical Rate of Rise of Turned-On Current	di/dt	V _D =2/3V _{DRM} , I _{TM} =2・I _O , T _j = 125 I _g =200mA, di _g /dt=0.2A/μs	100	A/μs
ピークゲート電力損失 Peak Gate Power	P _{GM}		5	W
平均ゲート電力損失 Average Gate Power	P _{G(AV)}		1	W
ピークゲート電流 Peak Gate Current	I _{GM}		2	A
ピークゲート電圧 Peak Gate Voltage	V _{GM}		10	V
ピークゲート逆電圧 Peak Gate Reverse Voltage	V _{RGM}		5	V

電気的特性 Electrical Characteristics

項目 Parameter	記号 Symbol	条件 Conditions	特性値(最大) Maximum Value			単位 Unit
			最小 Min.	標準 Typ.	最大 Max.	
ピークオフ電流 Peak Off-State Current	I _{DM}	T _j =125 , V _{DM} =V _{DRM}			10	mA
ピークオン電圧 Peak On-State Voltage	V _{TM}	T _j =25 , I _{TM} =90A			1.32	V
トリガゲート電流 Gate Current to Trigger	I _{GT}	V _D =6V , I _T =1A	T _j = - 40		200	mA
			T _j = 25		100	mA
			T _j = 125		50	mA
トリガゲート電圧 Gate Voltage to Trigger	V _{GT}	V _D =6V , I _T =1A	T _j = - 40		4.0	V
			T _j = 25		2.5	V
			T _j = 125		2.0	V
非トリガゲート電圧 Gate Non-Trigger Voltage	V _{GD}	T _j =125 , V _D =2/3V _{DRM}	0.25			V
臨界オフ電圧上昇率 Critical Rate of Rise of Off-State Voltage	dv/dt	T _j =125 , V _D =2/3V _{DRM}	500			V/μs
ターンオフ時間 Turn-Off Time	t _q	T _j =125 , I _{TM} =I _O , V _D =2/3V _{DRM} dv/dt=20V/μs, V _R =100V, - di/dt=20A/μs		150		μs
ターンオン時間 Turn-On Time	t _{gt}			6		μs
遅れ時間 Delay Time	t _d	T _j =25 , V _D =2/3V _{DRM} , I _{TM} =3・I _O I _g =200mA, di _g /dt=0.2A/μs		2		μs
立上がり時間 Rise Time	t _r			4		μs
ラッチング電流 Latching Current	I _L	T _j =25		90		mA
保持電流 Holding Current	I _H	T _j =25		70		mA
熱抵抗 Thermal Resistance	R _{th(j-c)}	接合部 - ケース間 Junction to Case			1.45	/W

定格・特性曲線

順電圧特性
FORWARD CURRENT VS. VOLTAGE

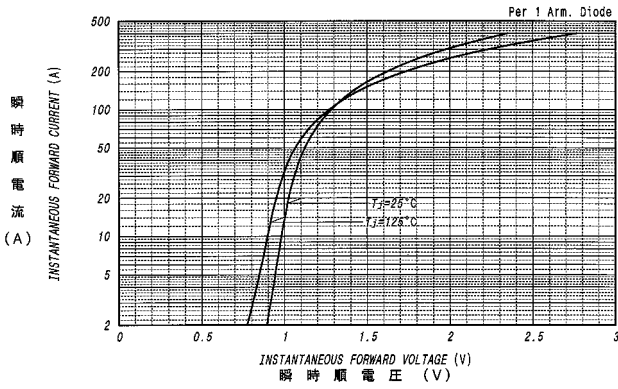

平均順電力損失特性
AVERAGE FORWARD POWER DISSIPATION

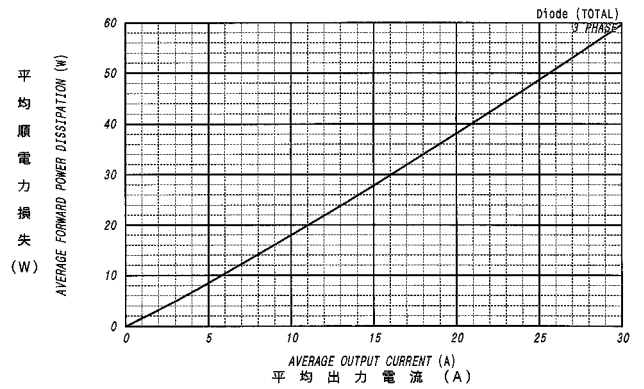

オン電圧特性
ON-STATE CURRENT VS. VOLTAGE

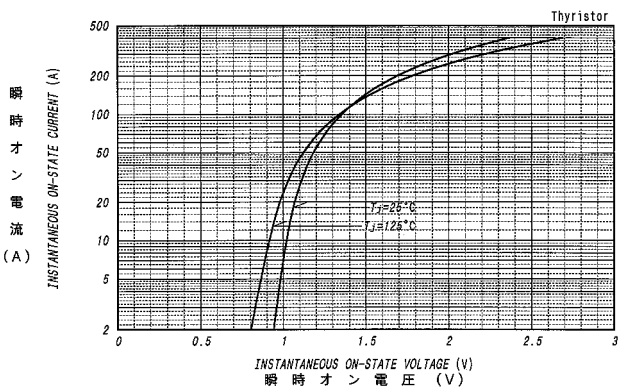

平均オン電力損失特性
AVERAGE ON-STATE POWER DISSIPATION

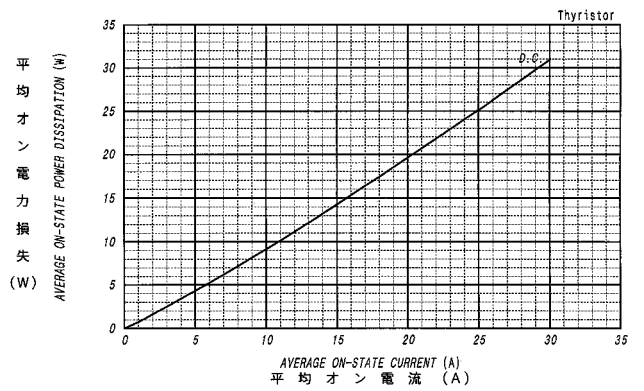

平均出力電流 - ケース温度定格
AVERAGE OUTPUT CURRENT VS. CASE TEMPERATURE
3-Phase Full Wave, Resistive or Inductive Load

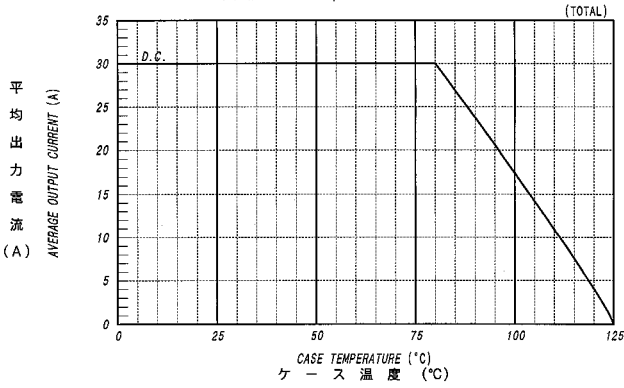

サージ順電流定格
SURGE CURRENT RATINGS
f=50Hz, Half Sine Wave, Non-Repetitive, Tj=125°C

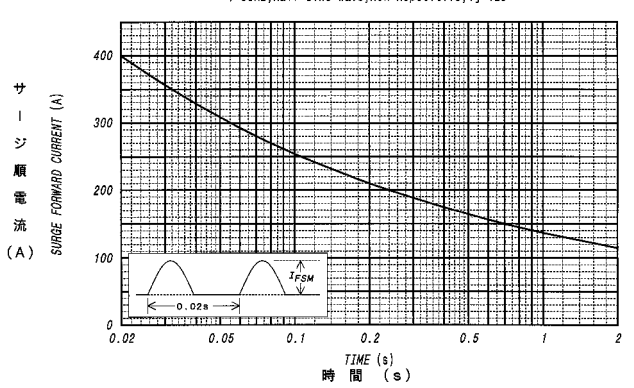

ゲート特性
GATE CHARACTERISTICS

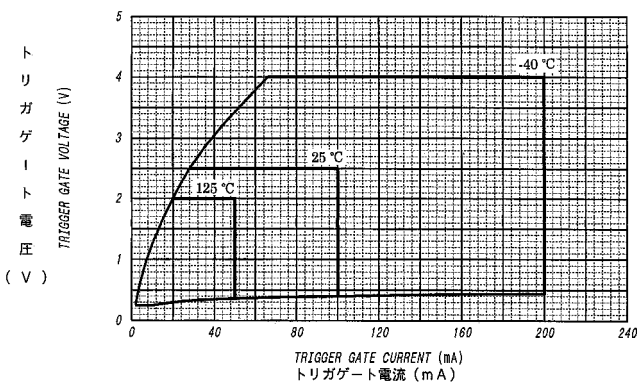

ゲート定格
GATE RATINGS

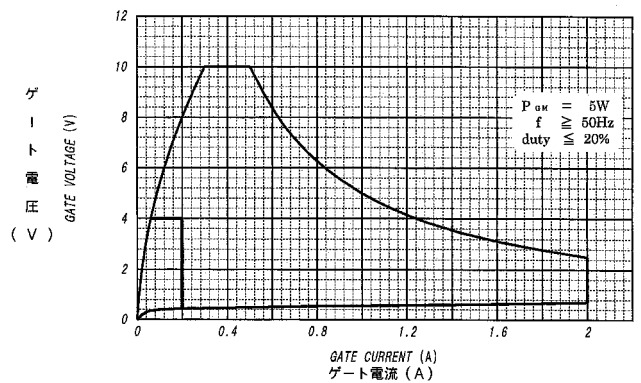

サイリスタモジュール