

## TFT LCD Approval Specification

# MODEL NO.: N133I6 - L0A

Customer:

Approved by:

Note:

記錄	工作	審核	角色	投票
2008-07-16 10:03:38	PMMD III Director	annie_hsu(徐凡琇 /56522 / 54873)	Director	Accept

- CONTENTS -

REVISION HISTORY	-----	4
1. GENERAL DESCRIPTION	-----	5
1.1 OVERVIEW		
1.2 FEATURES		
1.3 APPLICATION		
1.4 GENERAL SPECIFICATIONS		
1.5 MECHANICAL SPECIFICATIONS		
2. ABSOLUTE MAXIMUM RATINGS	-----	6
2.1 ABSOLUTE RATINGS OF ENVIRONMENT		
2.2 ELECTRICAL ABSOLUTE RATINGS		
2.2.1 TFT LCD MODULE		
2.2.2 BACKLIGHT UNIT		
3. ELECTRICAL CHARACTERISTICS	-----	8
3.1 TFT LCD MODULE		
3.2 BACKLIGHT UNIT		
4. BLOCK DIAGRAM	-----	11
4.1 TFT LCD MODULE		
4.2 BACKLIGHT UNIT		
5. INPUT TERMINAL PIN ASSIGNMENT	-----	12
5.1 TFT LCD MODULE		
5.2 TIMING DIAGRAM OF LVDS INPUT SIGNAL		
5.3 COLOR DATA INPUT ASSIGNMENT		
5.4 EDID DATA STRUCTURE		
6. CONVERTER SPECIFICATION	-----	19
6.1 INPUT CONNECTOR PIN ASSIGNMENT		
6.2 INPUT ELECTRICAL CHARACTERISTICS OF CONVERTER		
7. INTERFACE TIMING	-----	20
7.1 INPUT SIGNAL TIMING SPECIFICATIONS		
7.2 POWER ON/OFF SEQUENCE		
8. OPTICAL CHARACTERISTICS	-----	22
8.1 TEST CONDITIONS		
8.2 OPTICAL SPECIFICATIONS		
9. PRECAUTIONS	-----	25
9.1 HANDLING PRECAUTIONS		
9.2 STORAGE PRECAUTIONS		
9.3 OPERATION PRECAUTIONS		
10. PACKING	-----	26
10.1 CARTON		
10.2 PALLET		

11. DEFINITION OF LABELS  
11.1 CMO MODULE LABEL  
11.2 CMO CARTON LABE

----- 28

### REVISION HISTORY

Version	Date	Page (New)	Section	Description
0.0	Nov, 01,'07	All	All	Tentative specification was first issued.
1.0	May, 10,'08	All	All	Preliminary specification was first issued.
2.0	Jul. 10.'08	All	All	Approval specification was first issued

## 1. GENERAL DESCRIPTION

### 1.1 OVERVIEW

N133I6 - L0A is a 13.3" TFT Liquid Crystal Display module with LED Backlight unit and 40 pins LVDS interface. This module supports 1280 x 800 WXGA mode and can display 262,144 colors. The optimum viewing angle is at 6 o'clock direction. The converter module for Backlight is built in.

### 1.2 FEATURES

- Thin and Light Weight
- WXGA (1280 x 800 pixels) resolution
- DE only mode
- 3.3V LVDS (Low Voltage Differential Signaling) interface with 1 pixel/clock

### 1.3 APPLICATION

- TFT LCD Notebook

### 1.4 GENERAL SPECIFICATIONS

Item	Specification	Unit	Note
Active Area	286.08 (H) x 178.8 (V)	mm	(1)
Top Polarizer Area	289.48 (H) x 182.2 (V)	mm	
Driver Element	a-si TFT active matrix	-	-
Pixel Number	1280 x R.G.B. x 800	pixel	-
Pixel Pitch	0.2235 (H) x 0.2235 (V)	mm	-
Pixel Arrangement	RGB vertical stripe	-	-
Display Colors	262,144	color	-
Transmissive Mode	Normally white	-	-
Surface Treatment	Anti Glare	-	-

### 1.5 MECHANICAL SPECIFICATIONS

Item	Min.	Typ.	Max.	Unit	Note
Module Size	Horizontal(H)	--	304.75	--	(1)
	Vertical(V)	--	203.15	--	
	Depth(D)	3.55	3.7	3.85	
Weight	---	--	245	g	-
I/F connector mounting position	The mounting inclination of the connector makes the screen center within $\pm 0.5\text{mm}$ as the horizontal.				(2)

Note (1) Please refer to the attached drawings for more information of front and back outline dimensions.

Note (2) Connector mounting position

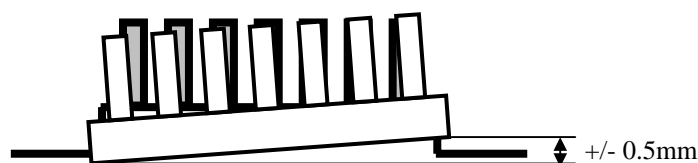

## 2. ABSOLUTE MAXIMUM RATINGS

### 2.1 ABSOLUTE RATINGS OF ENVIRONMENT

Item	Symbol	Value		Unit	Note
		Min.	Max.		
Storage Temperature	T <sub>ST</sub>	-20	+60	°C	(1)
Operating Ambient Temperature	T <sub>OP</sub>	0	+50	°C	(1), (2)
Shock (Non-Operating)	S <sub>NOP</sub>	-	200/2	G	(3), (5)
Vibration (Non-Operating)	V <sub>NOP</sub>	-	1.5	G	(4), (5)

Note (1) Temperature and relative humidity range is shown in the figure below.

- (a) 90 %RH Max. (Ta = 40 °C).
- (b) Wet-bulb temperature should be 39 °C Max. (Ta > 40 °C).
- (c) No condensation.

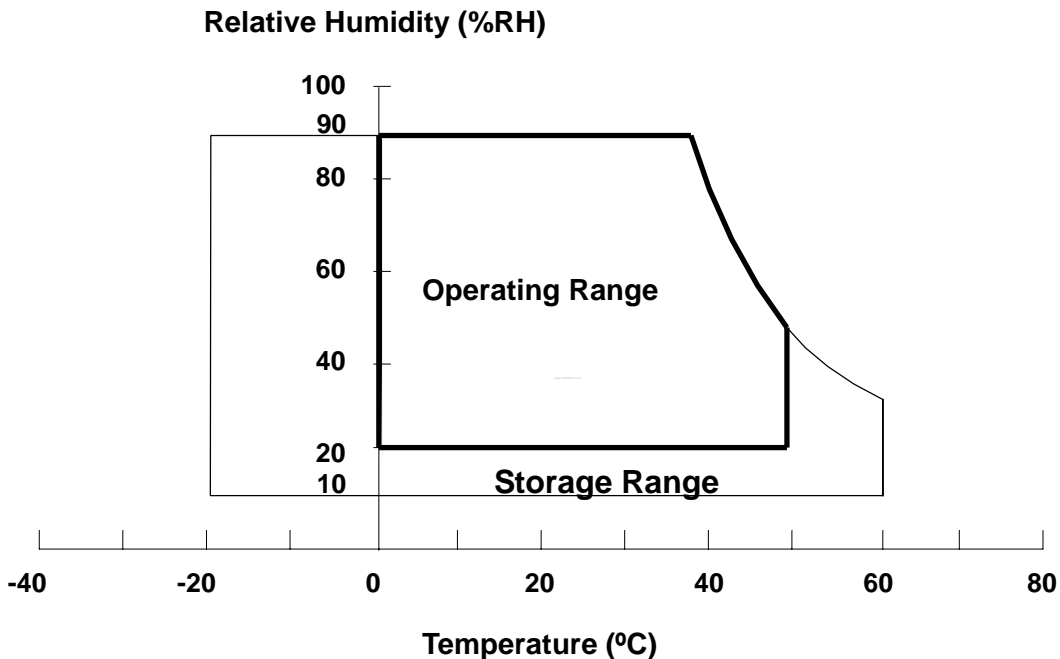

Note (2) The temperature of panel surface should be 0 °C Min. and 50 °C Max.

Note (3) 1 time for ± X, ± Y, ± Z. for Condition (200G / 2ms) is half Sine Wave,

Note (4) 10 ~ 500 Hz, 0.5 Hr / Cycle, 1 cycles for each X, Y, Z.

Note (5) At testing Vibration and Shock, the fixture in holding the module has to be hard and rigid enough so that the module would not be twisted or bent by the fixture.

The fixing condition is shown as below:

#### At Room Temperature

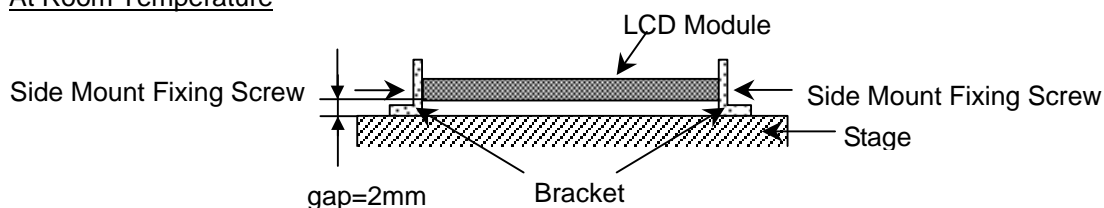

## 2.2 ELECTRICAL ABSOLUTE RATINGS

### 2.2.1 TFT LCD MODULE

Item	Symbol	Value		Unit	Note
		Min.	Max.		
Power Supply Voltage	$V_{CC}$	-0.3	+4.0	V	(1)
Logic Input Voltage	$V_{IN}$	-0.3	$V_{CC}+0.3$	V	

### 2.2.2 BACKLIGHT UNIT

Item	Value			Unit	Note
	Min	Typ.	Max.		
LED Light Bar Input voltage	27.0	--	30.6	$V_{DC}$	(1), (2)
LED Light Bar Input Current	--	(120)	--	$mA_{DC}$	

Note (1) Permanent damage to the device may occur if maximum values are exceeded. Function operation should be restricted to the conditions described under Normal Operating Conditions.

Note (2) Specified values are for LED (Refer to Section 3.2 for further information).

### 3. ELECTRICAL CHARACTERISTICS

#### 3.1 TFT LCD MODULE

Parameter	Symbol	Value			Unit	Note	
		Min.	Typ.	Max.			
Power Supply Voltage	V <sub>CC</sub>	3.0	3.3	3.6	V	-	
Permissible Ripple Voltage	V <sub>RP</sub>	-	50	-	mV	-	
Rush Current	I <sub>RUSH</sub>	-	-	1.5	A	(2)	
Initial Stage Current	I <sub>IS</sub>	-	-	1.0	A	(2)	
Power Supply Current	White	I <sub>CC</sub>	-	200	230	mA	(3)a
	Black		-	270	300	mA	(3)b
LVDS Differential Input High Threshold	V <sub>TH(LVDS)</sub>	-	-	+100	mV	(5), V <sub>CM</sub> =1.2V	
LVDS Differential Input Low Threshold	V <sub>TL(LVDS)</sub>	-100	-	-	mV	(5) V <sub>CM</sub> =1.2V	
LVDS Common Mode Voltage	V <sub>CM</sub>	1.125	-	1.375	V	(5)	
LVDS Differential Input Voltage	V <sub>ID</sub>	100	-	600	mV	(5)	
Terminating Resistor	R <sub>T</sub>	-	100	-	Ohm		
Power per EBL WG	P <sub>EBL</sub>	-	1.4	-	W	(4)	

Note (1) The ambient temperature is Ta = 25 ± 2 °C.

Note (2) I<sub>RUSH</sub>: the maximum current when VCC is rising

I<sub>IS</sub>: the maximum current of the first 100ms after power-on

Measurement Conditions: Shown as the following figure. Test pattern: black.

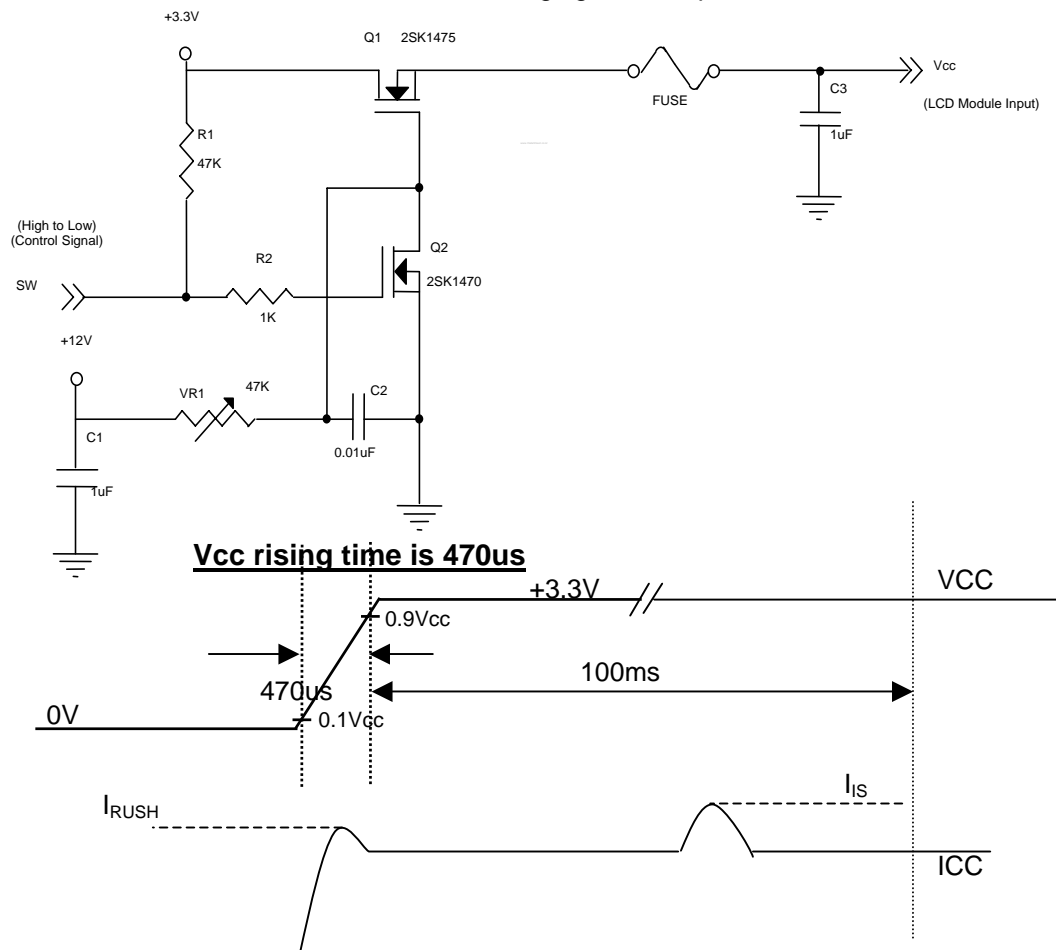



Note (3) The specified power supply current is under the conditions at  $V_{CC} = 3.3\text{ V}$ ,  $T_a = 25 \pm 2\text{ }^\circ\text{C}$ ,  $f_v = 60\text{ Hz}$ , whereas a power dissipation check pattern below is displayed.

a. White Pattern



Active Area

b. Black Pattern

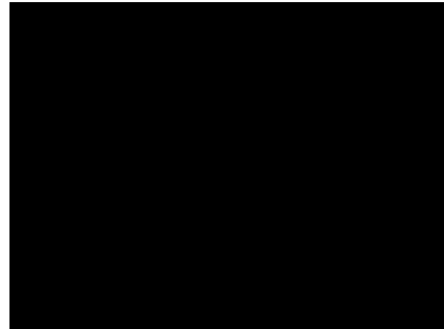

Active Area

Note (4) The specified power are the sum of LCD panel electronics input power and the converter input power. Test conditions are as follows.

- (a)  $V_{CC} = 3.3\text{ V}$ ,  $T_a = 25 \pm 2\text{ }^\circ\text{C}$ ,  $f_v = 60\text{ Hz}$ ,
- (b) The pattern used is a black and white 32 x 36 checkerboard, slide #100 from the VESA file "Flat Panel Display Monitor Setup Patterns", FPDMSU.ppt.
- (c) Luminance: 60 nits.

Note (5) The parameters of LVDS signals are defined as the following figures.

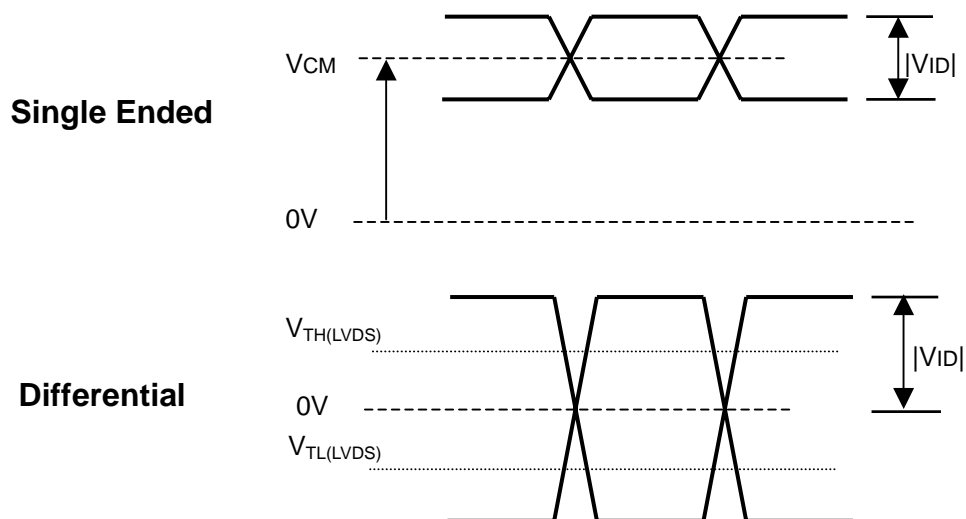

## 3.2 BACKLIGHT UNIT

 $T_a = 25 \pm 2 \text{ }^\circ\text{C}$ 

Parameter	Symbol	Value			Unit	Note
		Min.	Typ.	Max.		
LED light bar input voltage	$V_L$	27.0		30.6	$V_{RMS}$	(1), (Duty 100%)
LED light bar input current	$I_L$		120		$mA_{RMS}$	(1), (Duty 100%)
Power Consumption	$P_L$	3.24		3.68	W	(2), $I_L = 120 \text{ mA}$
LED Life Time	$L_{BL}$	10000	-	-	Hrs	(3)

Note (1) LED current is measured by utilizing a high frequency current meter as shown below:

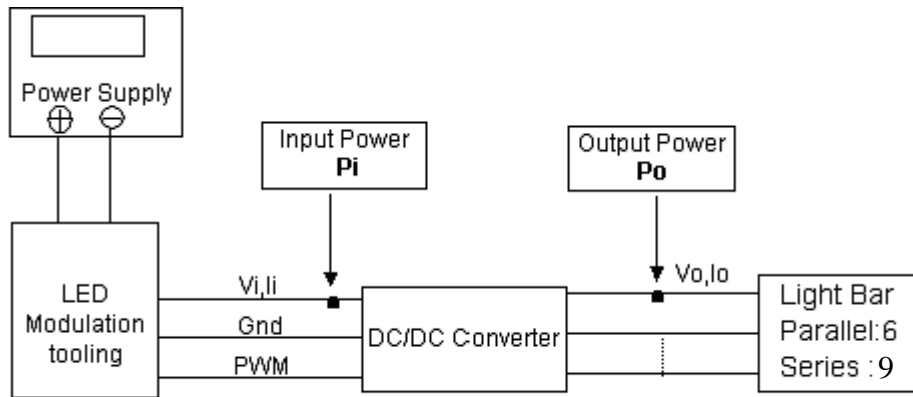

Note (2)  $P_L = I_o \times V_o$

Note (3) The lifetime of LED is defined as the time when it continues to operate under the conditions at  $T_a = 25 \pm 2 \text{ }^\circ\text{C}$  and  $I = 20 \text{ mA}$  (Per EA) until the brightness becomes 50% of its original value

#### 4. BLOCK DIAGRAM

##### 4.1 TFT LCD MODULE

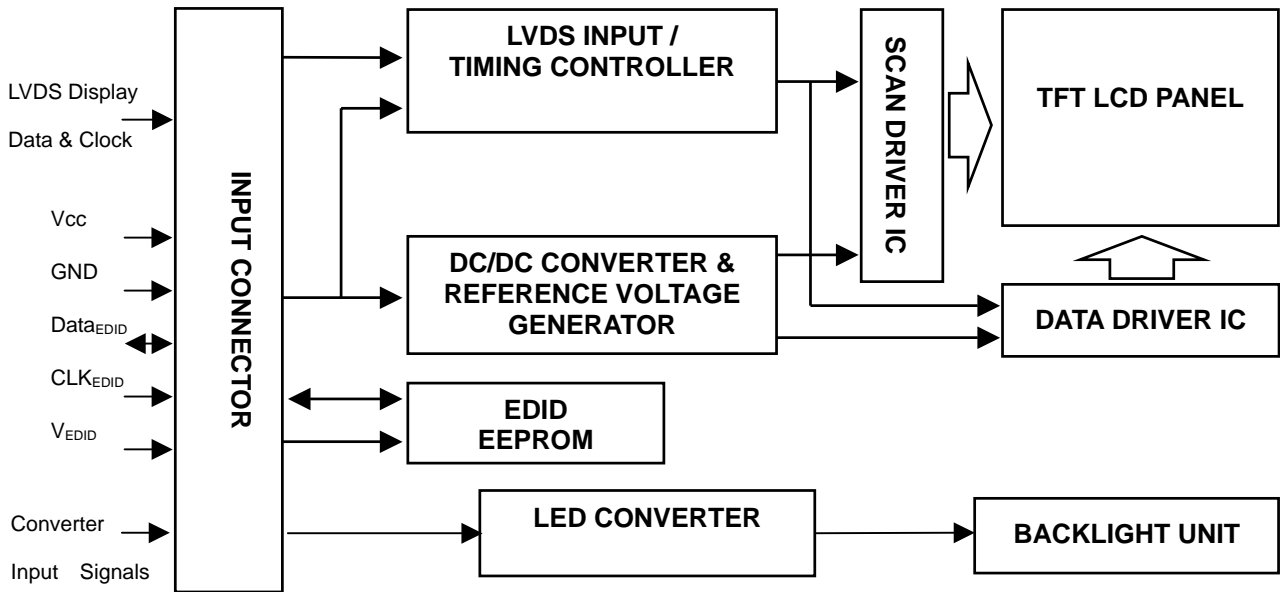

## 5. INPUT TERMINAL PIN ASSIGNMENT

### 5.1 TFT LCD MODULE

Pin	Symbol	Description	Polarity	Remark
1	VSS	Ground		
2	NC	no connect		
3	VDD	Logic power 3.3V		
4	VDD	Logic power 3.3V		
5	VDD	Logic power 3.3V		
6	VEDID	EDID 3.3V power		DDC 3.3V Power
7	NC	no connect		
8	CLK	EDID clock		DDC Clock
9	DATA	EDID data		DDC Data
10	VSS	Ground		
11	VSS	Ground		
12	NC	no connect		
13	RIN0-	- LVDS differential data input (R0-R5, G0)	Negative	R0~R5, G0
14	RIN0+	+ LVDS differential data input (R0-R5, G0)	Positive	
15	VSS0	Ground-LVDS0		
16	RIN1-	- LVDS differential data input (G1-G5, B0-B1)	Negative	G1~G5, B0, B1
17	RIN1+	+ LVDS differential data input (G1-G5, B0-B1)	Positive	
18	VSS1	Ground-LVDS1		
19	RIN2-	- LVDS differential data input (B2-B5, HS, VS, DE)	Negative	B2~B5, DE, Hsync, Vsync
20	RIN2+	+ LVDS differential data input (B2-B5, HS, VS, DE)	Positive	
21	VSS2	Ground-LVDS2		
22	CLK-	- LVDS differential clock input		LVDS Level Clock
23	CLK+	+ LVDS differential clock input		
24	VSS3	Ground-LVDS3		
25	INV_PWM / R_PWM	PWM brightness control		
26	LED_Enable	Enable LED		
27	VSS	LED Ground		
28	VSS	LED Ground		
29	VSS	LED Ground		
30	VSS	LED Ground		
31	NC	no connect		
32	VBL+	7V - 20V LED power		
33	VBL+	7V - 20V LED power		
34	VBL+	7V - 20V LED power		
35	VBL+	7V - 20V LED power		
36	VBL+	7V - 20V LED power		
37	NC	no connect		
38	NC	no connect		
39	NC	no connect		
40	VSS	Ground		

Note (1) Connector Part No.: 20347- 140E-02(I-PEX) or equivalent

Note (2) User's connector Part No: 20345-040T-02 (I-PEX) or equivalent

Note (3) The first pixel is odd as shown in the following figure.

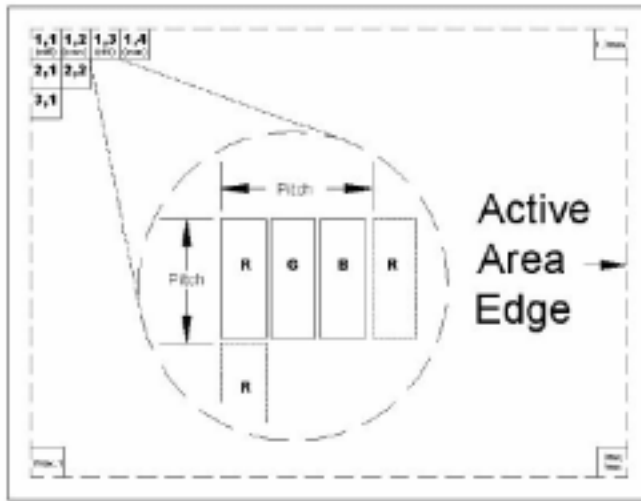

5.2 TIMING DIAGRAM OF LVDS INPUT SIGNAL

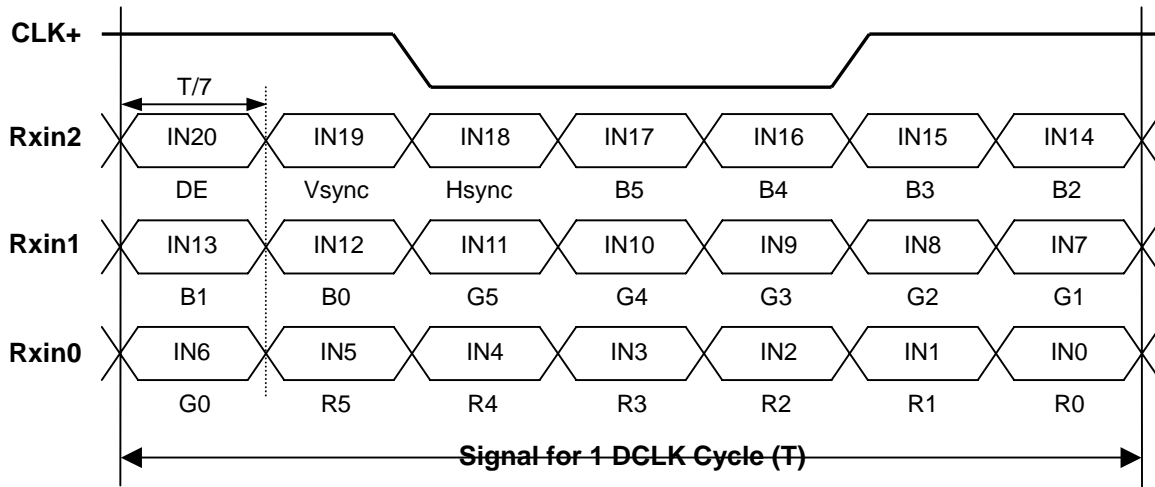

### 5.3 COLOR DATA INPUT ASSIGNMENT

The brightness of each primary color (red, green and blue) is based on the 6-bit gray scale data input for the color. The higher the binary input, the brighter the color. The table below provides the assignment of color versus data input.

Color		Data Signal																	
		Red						Green						Blue					
		R5	R4	R3	R2	R1	R0	G5	G4	G3	G2	G1	G0	B5	B4	B3	B2	B1	B0
Basic Colors	Black	0	0	0	0	0	0	0	0	0	0	0	0	0	0	0	0	0	0
	Red	1	1	1	1	1	1	0	0	0	0	0	0	0	0	0	0	0	0
	Green	0	0	0	0	0	0	1	1	1	1	1	1	0	0	0	0	0	0
	Blue	0	0	0	0	0	0	0	0	0	0	0	0	1	1	1	1	1	1
	Cyan	0	0	0	0	0	0	1	1	1	1	1	1	1	1	1	1	1	1
	Magenta	1	1	1	1	1	1	0	0	0	0	0	0	0	1	1	1	1	1
	Yellow	1	1	1	1	1	1	1	1	1	1	1	1	0	0	0	0	0	0
	White	1	1	1	1	1	1	1	1	1	1	1	1	1	1	1	1	1	1
Gray Scale Of Red	Red(0)/Dark	0	0	0	0	0	0	0	0	0	0	0	0	0	0	0	0	0	0
	Red(1)	0	0	0	0	0	1	0	0	0	0	0	0	0	0	0	0	0	0
	Red(2)	0	0	0	0	1	0	0	0	0	0	0	0	0	0	0	0	0	0
	:	:	:	:	:	:	:	:	:	:	:	:	:	:	:	:	:	:	:
	:	:	:	:	:	:	:	:	:	:	:	:	:	:	:	:	:	:	:
	:	:	:	:	:	:	:	:	:	:	:	:	:	:	:	:	:	:	:
	Red(61)	1	1	1	1	0	1	0	0	0	0	0	0	0	0	0	0	0	0
	Red(62)	1	1	1	1	1	0	0	0	0	0	0	0	0	0	0	0	0	0
Red(63)	1	1	1	1	1	1	0	0	0	0	0	0	0	0	0	0	0	0	
Gray Scale Of Green	Green(0)/Dark	0	0	0	0	0	0	0	0	0	0	0	0	0	0	0	0	0	0
	Green(1)	0	0	0	0	0	0	0	0	0	0	0	1	0	0	0	0	0	0
	Green(2)	0	0	0	0	0	0	0	0	0	0	1	0	0	0	0	0	0	0
	:	:	:	:	:	:	:	:	:	:	:	:	:	:	:	:	:	:	:
	:	:	:	:	:	:	:	:	:	:	:	:	:	:	:	:	:	:	:
	:	:	:	:	:	:	:	:	:	:	:	:	:	:	:	:	:	:	:
	Green(61)	0	0	0	0	0	0	1	1	1	1	0	1	0	0	0	0	0	0
	Green(62)	0	0	0	0	0	0	1	1	1	1	1	0	0	0	0	0	0	0
Green(63)	0	0	0	0	0	0	1	1	1	1	1	1	0	0	0	0	0	0	
Gray Scale Of Blue	Blue(0)/Dark	0	0	0	0	0	0	0	0	0	0	0	0	0	0	0	0	0	0
	Blue(1)	0	0	0	0	0	0	0	0	0	0	0	0	0	0	0	0	0	1
	Blue(2)	0	0	0	0	0	0	0	0	0	0	0	0	0	0	0	0	1	0
	:	:	:	:	:	:	:	:	:	:	:	:	:	:	:	:	:	:	:
	:	:	:	:	:	:	:	:	:	:	:	:	:	:	:	:	:	:	:
	:	:	:	:	:	:	:	:	:	:	:	:	:	:	:	:	:	:	:
	Blue(61)	0	0	0	0	0	0	0	0	0	0	0	0	1	1	1	1	0	1
	Blue(62)	0	0	0	0	0	0	0	0	0	0	0	0	1	1	1	1	1	0
Blue(63)	0	0	0	0	0	0	0	0	0	0	0	0	1	1	1	1	1	1	

Note (1) 0: Low Level Voltage, 1: High Level Voltage

#### 5.4 EDID DATA STRUCTURE

The EDID (Extended Display Identification Data) data formats are to support displays as defined in the VESA Plug & Display and FPGI standards.

Byte # (decimal)	Byte # (hex)	Field Name and Comments	Value (hex)	Value (binary)
0	0	Header	00	00000000
1	1	Header	FF	11111111
2	2	Header	FF	11111111
3	3	Header	FF	11111111
4	4	Header	FF	11111111
5	5	Header	FF	11111111
6	6	Header	FF	11111111
7	7	Header	00	00000000
8	8	EISA ID manufacturer name ("CMO")	0D	00001101
9	9	EISA ID manufacturer name (Compressed ASCII)	AF	10101111
10	0A	ID product code (N133I6-LOA)	13	00010011
11	0B	ID product code (hex LSB first; N133I6-LOA)	13	00010011
12	0C	ID S/N (fixed "0")	00	00000000
13	0D	ID S/N (fixed "0")	00	00000000
14	0E	ID S/N (fixed "0")	00	00000000
15	0F	ID S/N (fixed "0")	00	00000000
16	10	Week of manufacture (fixed week code)	23	00100011
17	11	Year of manufacture (fixed year code)	12	00010010
18	12	EDID structure version # ("1")	01	00000001
19	13	EDID revision # ("3")	03	00000011
20	14	Video I/P definition ("digital")	80	10000000
21	15	Active area horizontal 28.608cm	1D	00011101
22	16	Active area vertical 17.88cm	13	00010011
23	17	Display Gamma (Gamma = "2.2")	78	01111000
24	18	Feature support ("Active off, RGB Color")	0A	00001010
25	19	Red/Green (Rx1, Rx0, Ry1, Ry0, Gx1, Gx0, Gy1, Gy0)	5C	01011100
26	1A	Blue/White (Bx1, Bx0, By1, By0, Wx1, Wx0, Wy1, Wy0)	80	10000000
27	1B	Red-x (Rx = "0.622")	98	10011000
28	1C	Red-y (Ry = "0.346")	58	01011000
29	1D	Green-x (Gx = "0.333")	51	01010001
30	1E	Green-y (Gy = "0.528")	8E	10001110
31	1F	Blue-x (Bx = "0.164")	27	00100111
32	20	Blue-y (By = "0.162")	25	00100101
33	21	White-x (Wx = "0.313")	50	01010000
34	22	White-y (Wy = "0.329")	54	01010100
35	23	Established timings 1	00	00000000
36	24	Established timings 2	00	00000000
37	25	Manufacturer's reserved timings	00	00000000
38	26	Standard timing ID # 1	01	00000001
39	27	Standard timing ID # 1	01	00000001



40	28	Standard timing ID # 2	01	00000001
41	29	Standard timing ID # 2	01	00000001
42	2A	Standard timing ID # 3	01	00000001
43	2B	Standard timing ID # 3	01	00000001
44	2C	Standard timing ID # 4	01	00000001
45	2D	Standard timing ID # 4	01	00000001
46	2E	Standard timing ID # 5	01	00000001
47	2F	Standard timing ID # 5	01	00000001
48	30	Standard timing ID # 6	01	00000001
49	31	Standard timing ID # 6	01	00000001
50	32	Standard timing ID # 7	01	00000001
51	33	Standard timing ID # 7	01	00000001
52	34	Standard timing ID # 8	01	00000001
53	35	Standard timing ID # 8	01	00000001
54	36	Detailed timing description # 1 Pixel clock ("71MHz", According to VESA CVT Rev1.1)	BC	10111100
55	37	# 1 Pixel clock (hex LSB first)	1B	00011011
56	38	# 1 H active ("1280")	00	00000000
57	39	# 1 H blank ("160")	A0	10100000
58	3A	# 1 H active : H blank ("1280 : 160")	50	01010000
59	3B	# 1 V active ("800")	20	00100000
60	3C	# 1 V blank ("23")	17	00010111
61	3D	# 1 V active : V blank ("800 :23")	30	00110000
62	3E	# 1 H sync offset ("48")	30	00110000
63	3F	# 1 H sync pulse width ("32")	20	00100000
64	40	# 1 V sync offset : V sync pulse width ("3 : 6")	36	00110110
65	41	# 1 H sync offset : H sync pulse width : V sync offset : V sync width ("48: 32 : 3 : 6")	00	00000000
66	42	# 1 H image size ("286 mm")	1E	00011110
67	43	# 1 V image size ("179 mm")	B3	10110011
68	44	# 1 H image size : V image size ("286 : 179")	10	00010000
69	45	# 1 H boarder ("0")	00	00000000
70	46	# 1 V boarder ("0")	00	00000000
71	47	# 1 Non-interlaced, Normal, no stereo, Separate sync, H/V pol Negatives	19	00011001
72	48	Detailed timing description # 2	00	00000000
73	49	# 2 Flag	00	00000000
74	4A	# 2 Reserved	00	00000000
75	4B	# 2 FE (hex) defines ASCII string (Model Name "N133I6-LOA", ASCII)	FE	11111110
76	4C	# 2 Flag	00	00000000
77	4D	# 2 1st character of name ("N")	4E	01001110
78	4E	# 2 2nd character of name ("1")	31	00110001
79	4F	# 2 3rd character of name ("3")	33	00110011
80	50	# 2 4th character of name ("3")	33	00110011
81	51	# 2 5th character of name ("I")	49	01001001
82	52	# 2 6th character of name ("6")	36	00110110
83	53	# 2 7th character of name ("-")	2D	00101101
84	54	# 2 8th character of name ("L")	4C	01001100

85	55	# 2 9th character of name ("0")	30	00110000
86	56	# 2 9th character of name ("A")	41	01000001
87	57	# 2 New line character indicates end of ASCII string	0A	00001010
88	58	# 2 Padding with "Blank" character	20	00100000
89	59	# 2 Padding with "Blank" character	20	00100000
90	5A	Detailed timing description # 3	00	00000000
91	5B	# 3 Flag	00	00000000
92	5C	# 3 Reserved	00	00000000
93	5D	# 3 FE (hex) defines ASCII string (Vendor "CMO", ASCII)	FE	11111110
94	5E	# 3 Flag	00	00000000
95	5F	# 3 1st character of string ("C")	43	01000011
96	60	# 3 2nd character of string ("M")	4D	01001101
97	61	# 3 3rd character of string ("O")	4F	01001111
98	62	# 3 New line character indicates end of ASCII string	0A	00001010
99	63	# 3 Padding with "Blank" character	20	00100000
100	64	# 3 Padding with "Blank" character	20	00100000
101	65	# 3 Padding with "Blank" character	20	00100000
102	66	# 3 Padding with "Blank" character	20	00100000
103	67	# 3 Padding with "Blank" character	20	00100000
104	68	# 3 Padding with "Blank" character	20	00100000
105	69	# 3 Padding with "Blank" character	20	00100000
106	6A	# 3 Padding with "Blank" character	20	00100000
107	6B	# 3 Padding with "Blank" character	20	00100000
108	6C	Detailed timing description # 4	00	00000000
109	6D	# 4 Flag	00	00000000
110	6E	# 4 Reserved	00	00000000
111	6F	# 4 FE (hex) defines ASCII string (Model Name"N13316-LOA", ASCII)	FE	11111110
112	70	# 4 Flag	00	00000000
113	71	# 4 1st character of name ("N")	4E	01001110
114	72	# 4 2nd character of name ("1")	31	00110001
115	73	# 4 3rd character of name ("3")	33	00110011
116	74	# 4 4th character of name ("3")	33	00110011
117	75	# 4 5th character of name ("I")	49	01001001
118	76	# 4 6th character of name ("6")	36	00110110
119	77	# 4 7th character of name ("-")	2D	00101101
120	78	# 4 8th character of name ("L")	4C	01001100
121	79	# 4 9th character of name ("0")	30	00110000
122	7A	# 4 9th character of name ("A")	41	01000001
123	7B	# 4 New line character indicates end of ASCII string	0A	00001010
124	7C	# 4 Padding with "Blank" character	20	00100000
125	7D	# 4 Padding with "Blank" character	20	00100000
126	7E	Extension flag	00	00000000
127	7F	Checksum	2D	00101101

## 6 CONVERTER SPECIFICATION

### 6.1 ABSOLUTE MAXIMUM RATINGS

Symbol	Ratings
V <sub>in</sub>	40.0V
Gnd	+/-0.3V
PWM, EN	-0.3V~6.0V

### 6.2 RECOMMENDED OPERATING RATINGS

Parameter	Symbol	Value			Unit	Note
		Min.	Typ.	Max.		
Converter Input power supply voltage	V <sub>in</sub>	7.0	12.0	21.0	V	
EN Control Level	Backlight on	2.0	---	5.5	V	
	Backlight off	0	---	0.8	V	
PWM Control Level	PWM High Level	2.0	---	5.5	V	
	PWM Low Level	0	---	0.8	V	
PWM Control Duty Ratio		20		100	%	
PWM Control Frequency	f <sub>PWM</sub>	180	200	220	Hz	
Converter Input Current	V <sub>in</sub> =7 V		600	650	mA	(1)
	V <sub>in</sub> =21V		200	220	mA	(2)

Note (1) The specified LED power supply current is under the conditions at V<sub>in</sub> = 7 V, T<sub>a</sub> = 25 ± 2 °C, f<sub>PWM</sub> = 200 Hz, Duty=100%.

Note (2) The specified LED power supply current is under the conditions at V<sub>in</sub> = 21V, T<sub>a</sub> = 25 ± 2 °C, f<sub>PWM</sub> = 200 Hz, Duty=100%.

## 7. INTERFACE TIMING

### 7.1 INPUT SIGNAL TIMING SPECIFICATIONS

The specifications of input signal timing are as the following table and timing diagram.

Signal	Item	Symbol	Min.	Typ.	Max.	Unit	Note
DCLK	Frequency	1/Tc	50	71	80	MHz	-
DE	Vertical Total Time	TV	803	823	1028	TH	-
	Vertical Addressing Time	TVD	800	800	800	TH	-
	Vertical Active Blanking Period	TVB	TV-TVD	23	TV-TVD	TH	-
	Horizontal Total Time	TH	1362	1440	1800	Tc	-
	Horizontal Addressing Time	THD	1280	1280	1280	Tc	-
	Horizontal Active Blanking Period	THB	TH-THD	160	TH-THD	Tc	-

Note (1) Because this module is operated by DE only mode, Hsync and Vsync are ignored.

#### INPUT SIGNAL TIMING DIAGRAM

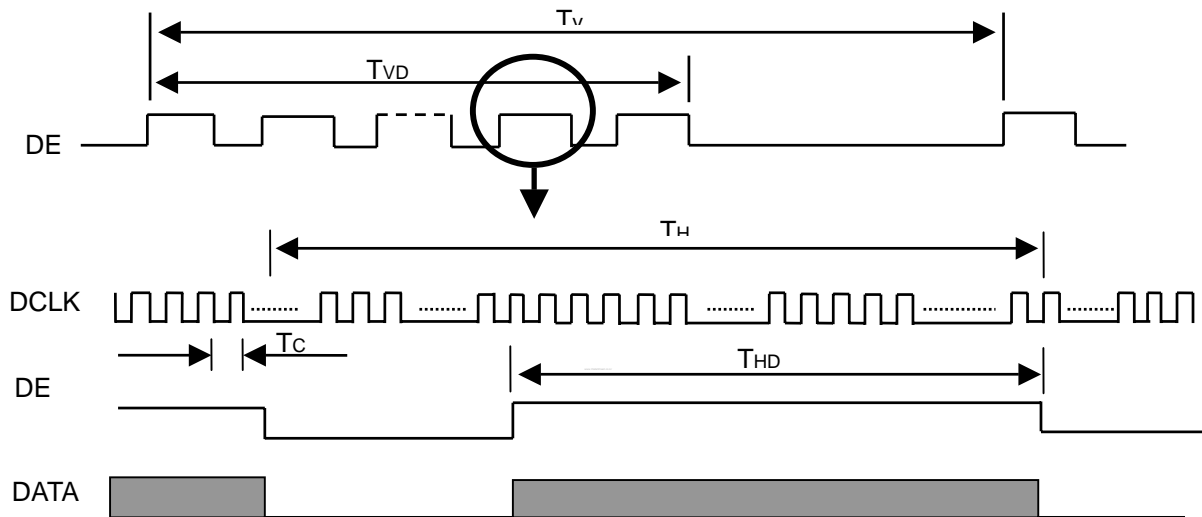

## 7.2 POWER ON/OFF SEQUENCE

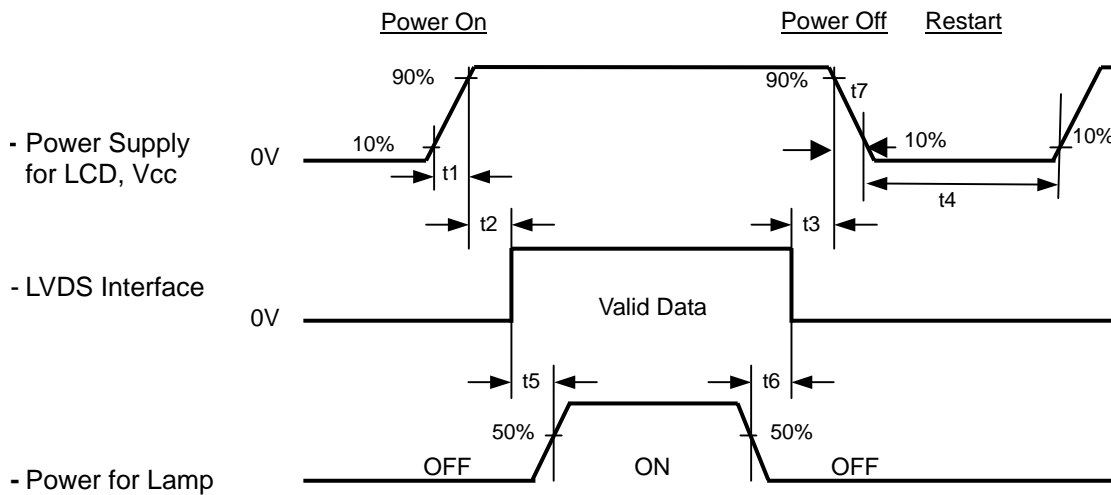

### Timing Specifications:

0.5	t1	10 ms
0	t2	50 ms
0	t3	50 ms
	t4	500 ms
	t5	200 ms
	t6	200 ms

Note (1) Please follow the power on/off sequence described above. Otherwise, the LCD module might be damaged.

Note (2) Please avoid floating state of interface signal at invalid period. When the interface signal is invalid, be sure to pull down the power supply of LCD Vcc to 0 V.

Note (3) The Backlight converter power must be turned on after the power supply for the logic and the interface signal is valid. The Backlight converter power must be turned off before the power supply for the logic and the interface signal is invalid.

Note (4) Sometimes some slight noise shows when LCD is turned off (even backlight is already off). To avoid this phenomenon, we suggest that the Vcc falling time is better to follow  $5 \times t7 \approx 300$  ms.

## 8 OPTICAL CHARACTERISTICS

### 8.1 TEST CONDITIONS

Item	Symbol	Value	Unit
Ambient Temperature	Ta	25±2	°C
Ambient Humidity	Ha	50±10	%RH
Supply Voltage	V <sub>CC</sub>	3.4	V
Input Signal	According to typical value in "3. ELECTRICAL CHARACTERISTICS"		
LED Light Bar Input Current	I <sub>L</sub>	(120)	mA

The measurement methods of optical characteristics are shown in Section 7.2. The following items should be measured under the test conditions described in Section 7.1 and stable environment shown in Note (6).

### 8.2 OPTICAL SPECIFICATIONS

Item		Symbol	Condition	Min.	Typ.	Max.	Unit	Note	
Contrast Ratio		CR	θ <sub>x</sub> =0°, θ <sub>y</sub> =0° Viewing Normal Angle	200	300		-	(2), (5)	
Response Time		T <sub>R</sub>		-	5	10	ms	(3)	
		T <sub>F</sub>		-	11	16	ms		
Average Luminance of White		L <sub>Ave</sub>			240	300		cd/m <sup>2</sup>	(4), (5)
White Variation		δW					1.4	-	(5), (6)
Color Chromaticity	Red	R <sub>x</sub>		Viewing Normal Angle	TYP. -0.05	0.584	TYP. +0.05	-	(1)
		R <sub>y</sub>				0.337		-	
	Green	G <sub>x</sub>				0.331		-	
		G <sub>y</sub>				0.572		-	
	Blue	B <sub>x</sub>				0.156		-	
		B <sub>y</sub>	0.133			-			
	White	W <sub>x</sub>	0.313			-			
		W <sub>y</sub>	0.329			-			
Viewing Angle	Horizontal	θ <sub>x+</sub>	CR≥10	40	45		Deg.		
		θ <sub>x-</sub>		40	45				
	Vertical	θ <sub>y+</sub>		15	20				
		θ <sub>y-</sub>		40	45				

Note (1) Definition of Viewing Angle ( $\theta_x$ ,  $\theta_y$ ):

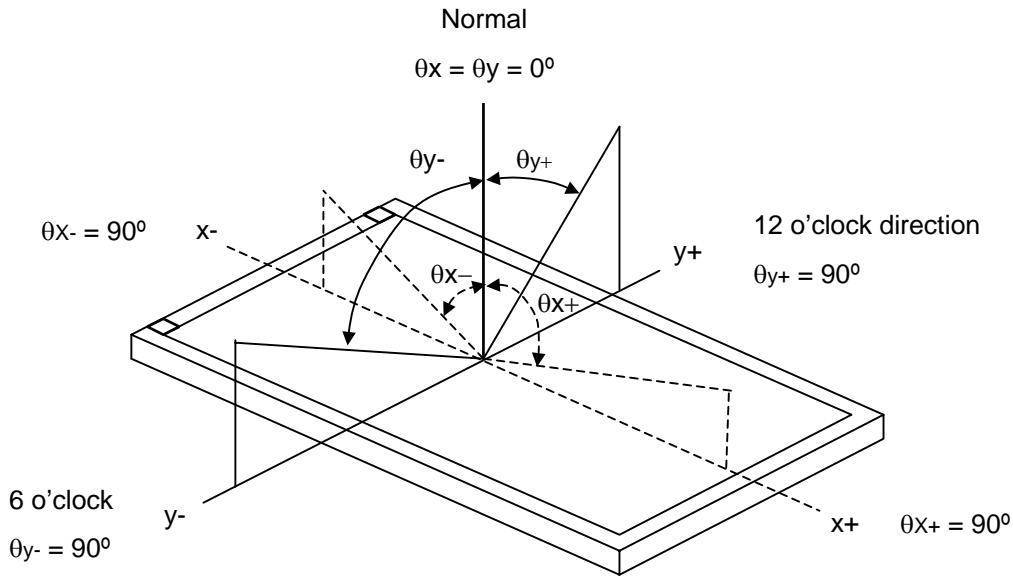

Note (2) Definition of Contrast Ratio (CR):

The contrast ratio can be calculated by the following expression.

$$\text{Contrast Ratio (CR)} = L_{63} / L_0$$

L<sub>63</sub>: Luminance of gray level 63

L<sub>0</sub>: Luminance of gray level 0

$$\text{CR} = \text{CR} (5)$$

CR (X) is corresponding to the Contrast Ratio of the point X at Figure in Note (6).

Note (3) Definition of Response Time ( $T_R$ ,  $T_F$ ) and measurement method:

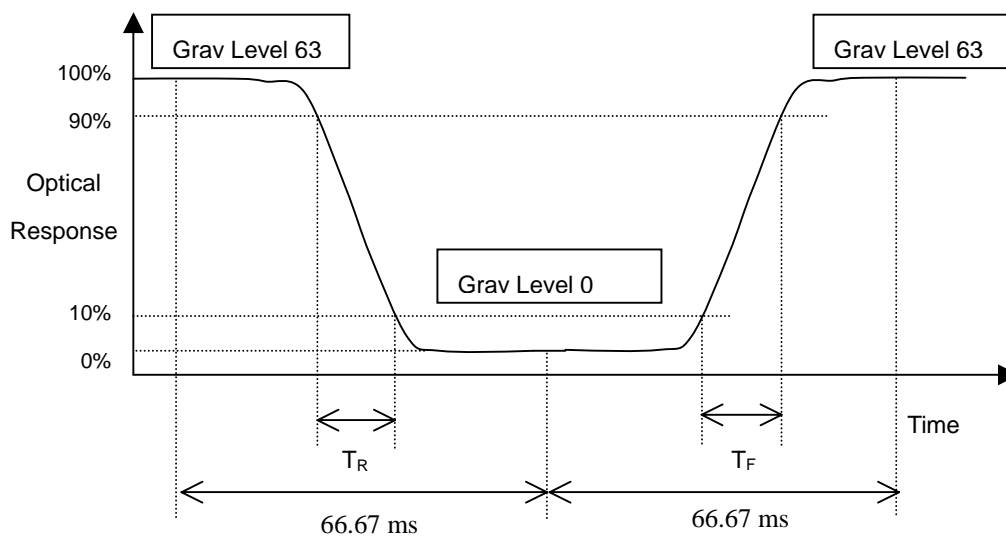

Note (4) Definition of Average Luminance of White ( $L_{AVE}$ ):

Measure the luminance of gray level 63 at 5 points

$$L_{AVE} = [L(1) + L(2) + L(3) + L(4) + L(5)] / 5$$

$L(x)$  is corresponding to the luminance of the point X at Figure in Note (6).

Note (5) Measurement Setup:

The LCD module should be stabilized at given temperature for 15 minutes to avoid abrupt temperature change during measuring. In order to stabilize the luminance, the measurement should be executed after lighting Backlight for 15 minutes in a windless room.

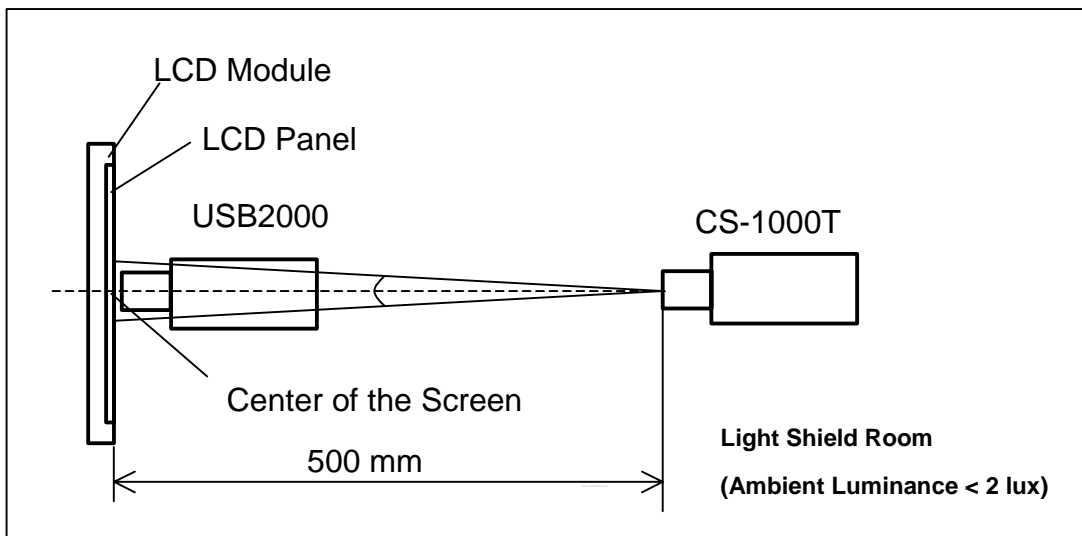

Note (6) Definition of White Variation ( $\delta W$ ):

Measure the luminance of gray level 63 at 5 points

$$\delta W = \text{Maximum} [L(1), L(2), L(3), L(4), L(5)] / \text{Minimum} [L(1), L(2), L(3), L(4), L(5)]$$

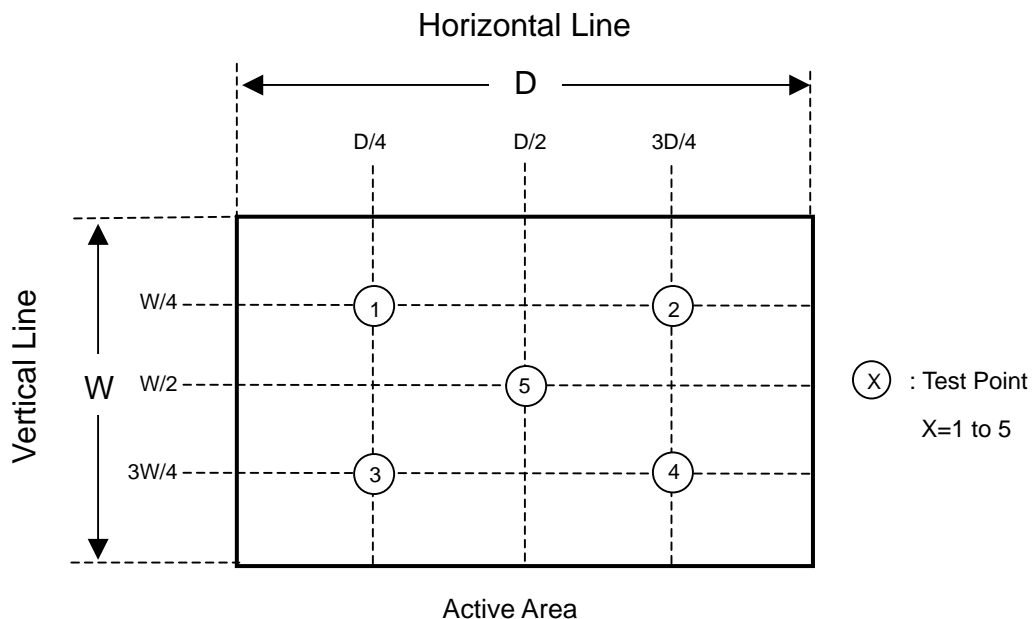



## 9. PRECAUTIONS

### 9.1 ASSEMBLY AND HANDLING PRECAUTIONS

- (1) Do not apply rough force such as bending or twisting to the module during assembly.
- (2) To assemble or install module into user's system can be only in clean working areas. The dust and oil may cause electrical short or worsen the polarizer.
- (3) It's not permitted to have pressure or impulse on the module because the LCD panel and Backlight will be damaged.
- (4) Always follow the correct power sequence when LCD module is connecting and operating. This can prevent damage to the CMOS LSI chips during latch-up.
- (5) Do not pull the I/F connector in or out while the module is operating.
- (6) Do not disassemble the module.
- (7) Use a soft dry cloth without chemicals for cleaning, because the surface of polarizer is very soft and easily scratched.
- (8) It is dangerous that moisture come into or contacted the LCD module, because moisture may damage LCD module when it is operating.
- (9) High temperature or humidity may reduce the performance of module. Please store LCD module within the specified storage conditions.
- (10) When ambient temperature is lower than 10°C may reduce the display quality. For example, the response time will become slowly, and the starting voltage of CCFL will be higher than room temperature.

### 9.2 SAFETY PRECAUTIONS

- (1) The startup voltage of Backlight is approximately 1000 Volts. It may cause electrical shock while assembling with converter. Do not disassemble the module or insert anything into the Backlight unit.
- (2) If the liquid crystal material leaks from the panel, it should be kept away from the eyes or mouth. In case of contact with hands, skin or clothes, it has to be washed away thoroughly with soap.
- (3) After the module's end of life, it is not harmful in case of normal operation and storage.

### 9.3 OPERATION PRECAUTIONS

- (1) Do not pull the I/F connector in or out while the module is operating.
- (2) Always follow the correct power on/off sequence when LCD module is connecting and operating. This can prevent the CMOS LSI chips from damage during latch-up.

## 10. PACKAGING

### 10.1 CARTON

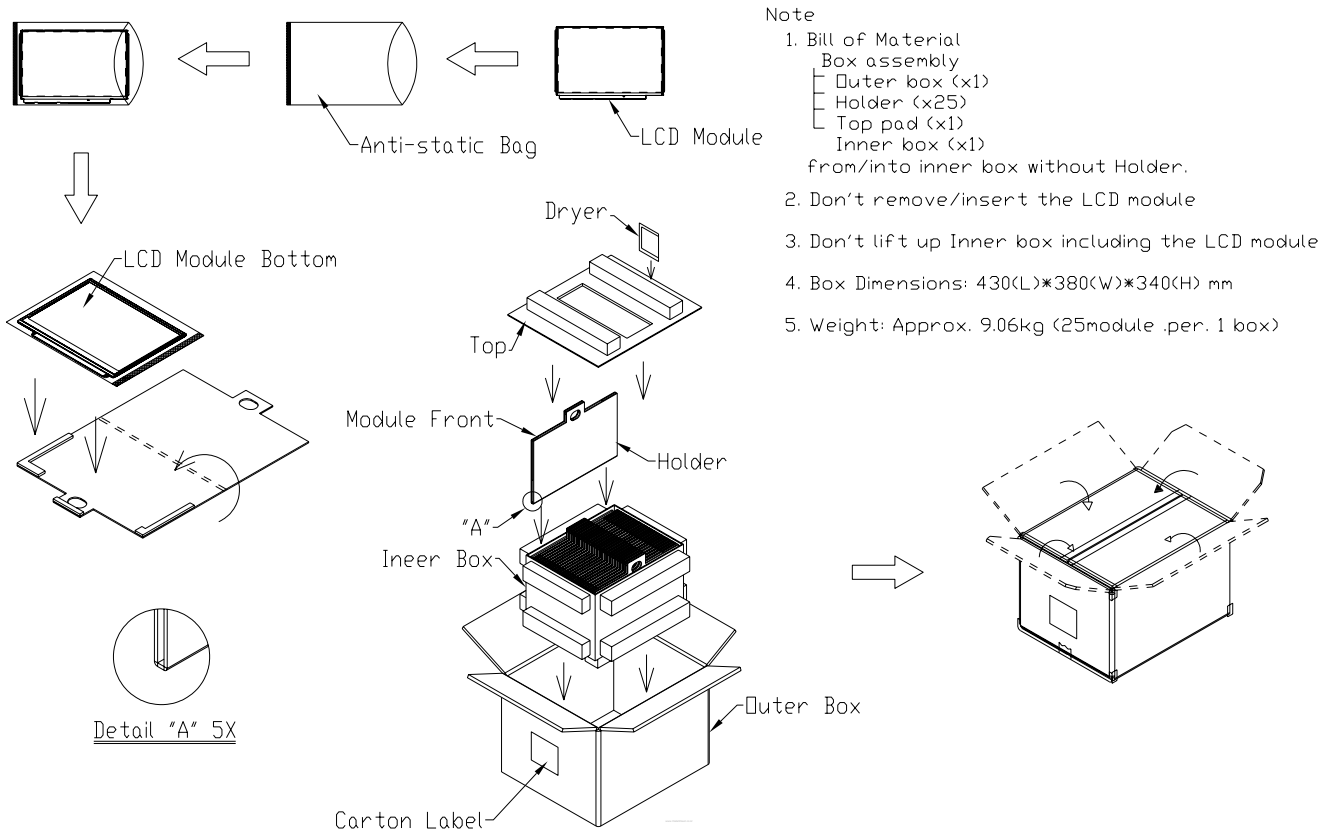

**Figure. 9-1 Packing method**

10.2 PALLET

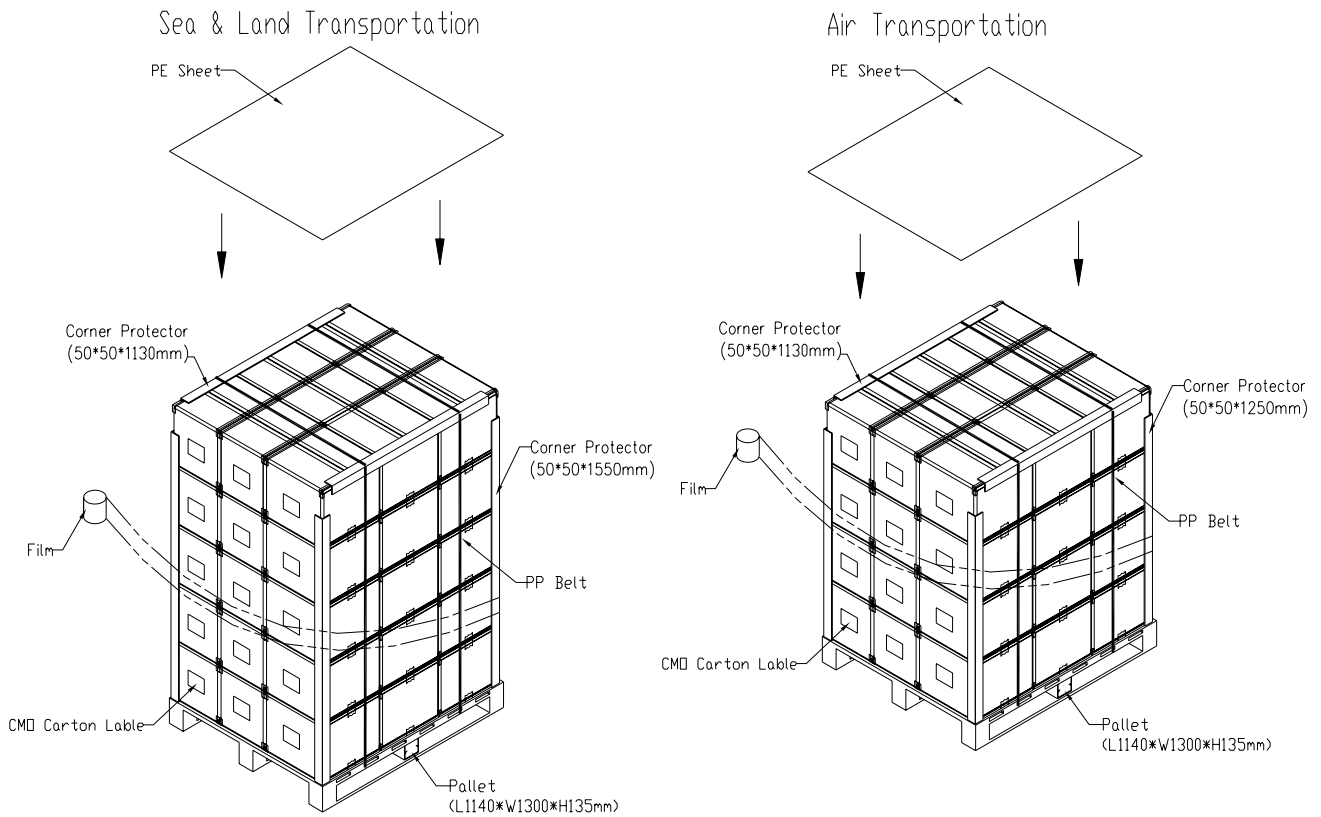

**Figure. 9-2 Packing method**

## 11. DEFINITION OF LABELS

### 11.1 CMO MODULE LABEL

The barcode nameplate is pasted on each module as illustration, and its definitions are as following explanation.



- (a) Model Name: N133I6 - L0A
- (b) Revision: Rev. XX, for example: A1, ..., C1, C2 ...etc.
- (c) Serial ID: XXXXXXYMDLNNNN

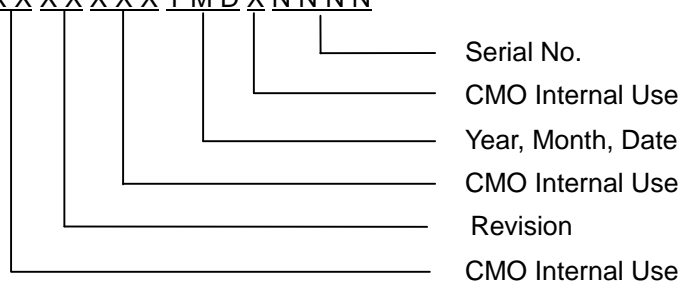

- (d) Production Location: MADE IN XXXX. XXXX stands for production location.

Serial ID includes the information as below:

- (a) Manufactured Date: Year: 1~9, for 2001~2009  
 Month: 1~9, A~C, for Jan. ~ Dec.  
 Day: 1~9, A~Y, for 1<sup>st</sup> to 31<sup>st</sup>, exclude I , O and U
- (b) Revision Code: cover all the change
- (c) Serial No.: Manufacturing sequence of product

11.2 CMO CARTON LABEL



The image shows a template for a CMO carton label. It features the CHI MEI logo and name at the top left. Below this, there are four lines for text entry: "PO.NO.", "Part ID.", "Model Name", and "Carton ID." followed by "Quantities". A large, faint "CMO" watermark is visible in the background. At the bottom, there is a "Made In XXXX" field and a circular "GP" logo with "RoHS" text below it. The entire label is enclosed in a blue border.

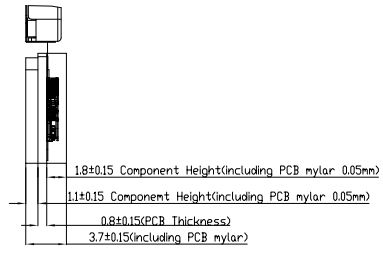
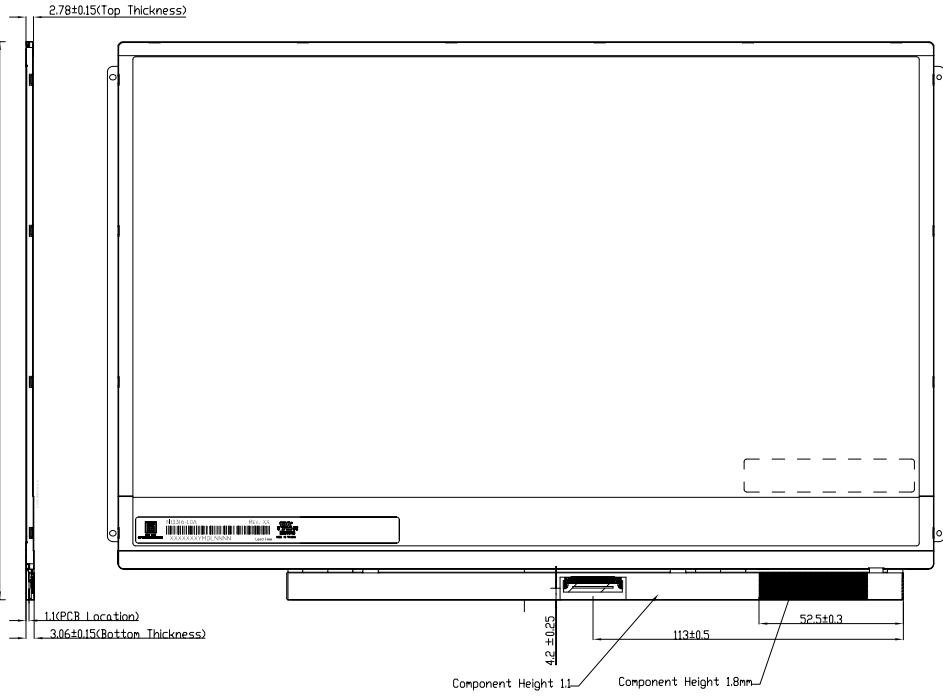
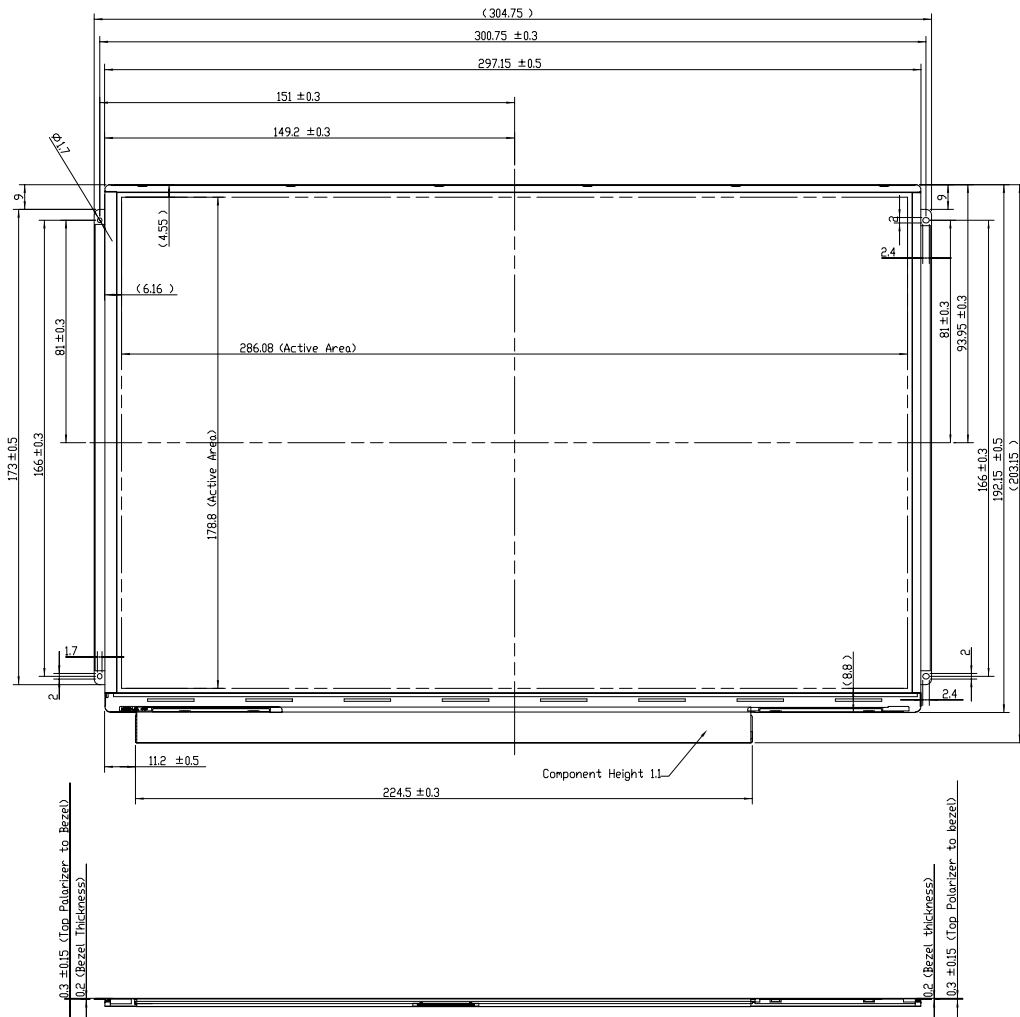

NOTE:  
 1. OUTLINE TOLERANCE: ± 0.5mm.  
 2. \* MARKS THE DESIGN CRITICAL DIMENSION.  
 3. (⊕) MARKS THE PROCESS CRITICAL DIMENSION.  
 4. LVDS: 1-PCX 20347-140E-02  
 5. Flatness 0.5mm Max.

TITLE: ASSY_MODULE_N13316-L0A		PD REV: A	
Approved: SHUNNAN		SD REV: 1	
Checked: JACKSON_CHEN	Drawing No: N133641A1A	Part No: TBD	
Drawer: YAOCHEN	Material: TBD	Sheet: 1 / 1	AI
Designer: YAOCHEN	Date: 18-Oct-2007	Scale: 1:1	Unit: mm
CHI MEI OPTOELECTRONICS CORP.		ALL RIGHTS RESERVED. COPYING FORBIDDEN.	

Mark	Description	Date	Changed_By	Approved_By	ECN No.	Remark
1						
2						
3						
4						