



Single/Dual/Triple/Quad Operational Amplifiers

ICL761X-ICL764X

General Description

The ICL761X-ICL764X family of monolithic CMOS op amps combine ultra-low input current with low-power operation over a wide supply voltage range. With pin-selectable quiescent currents of 10µA, 100µA, or 1000µA per amplifier, these op amps will operate from ±1V to ±8V power supplies, or from single supplies from 2V to 16V. The CMOS outputs swing to within millivolts of the supply voltages.

The ultra-low bias current of 1pA makes this family of op amps ideal for long time constant integrators, picoammeters, low droop rate sample/hold amplifiers and other applications where input bias and offset currents are critical. A low noise current of 0.01pA/√Hz and an input impedance of 10¹²Ω ensure optimum performance with very high source impedances in such applications as pH meters and photodiode amplifiers.

Applications

- Battery-Powered Instruments
- Low-Leakage Amplifiers
- Long-Time Constant Integrators
- Low-Frequency Active Filters
- Hearing Aids and Microphone Amplifiers
- Low Droop Rate Sample/Hold Amplifiers
- Picoammeters

Pin Configuration

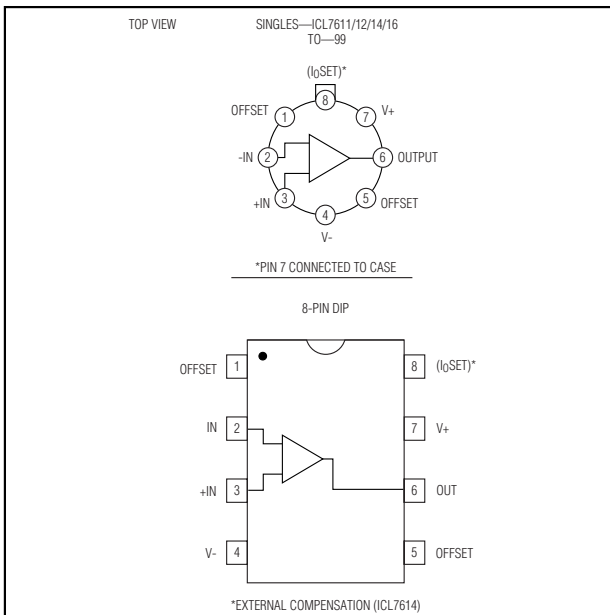

Features

- ◆ Pin-for-Pin Second Source
- ◆ 1pA Typical Bias Current—4nA (max) at +125°C
- ◆ ±1V to ±8V Wide Supply Voltage Range
- ◆ Industry-Standard Pinouts
- ◆ Programmable Quiescent Currents of 10µA, 100µA, and 1000µA
- ◆ Monolithic, Low-Power CMOS Design

Ordering Information

ICL76XX	M	N	OP
	Vos SELECTION	TEMP RANGE	PKG CODE
	A = 2mV	C = 0°C to 70°C	TV= 8-Pin TO-99
	B = 5mV	E = -40°C to +85°C	PA = 8-Pin Plastic Dip
	C = 10mV	M = -55°C to +125°C	SA = 8-Pin Small SO
	D = 15mV		JD = 14-Pin Cerdip
	E = 20mV		PD = 14-Pin Plastic Dip
			SD = 14-Pin Small SO
			JE = 16-Pin Cerdip
			PE = 16-Pin Plastic Dip
			SE = 16-Pin Small SO
			WE = 16-Pin Wide SO

Typical Operating Circuit appears at end of data sheet.



Single/Dual/Triple/Quad Operational Amplifiers

Ordering Information (continued)

	ICL7611	ICL7612	ICL7614	ICL7616	ICL7621	ICL7622	ICL7631	ICL7632	ICL7641	ICL7642
Compensated	X	X		X	X	X	X		X	X
Externally Compensated			X							
Extended CMVR		X		X						
Offset null capability	X	X	X	X		X				
Programmable I _Q	X	X		X			X	X		
Fixed I _Q -10μA										X
Fixed I _Q -100μA			X		X	X				
Fixed I _Q -1mA										X

Ordering Information (Single/Dual)

PART	TEMP RANGE	PIN-PACKAGE
ICL761XACPA	0°C to +70°C	8 Plastic Dip
ICL761XACSA	0°C to +70°C	8 Slim SO
ICL761XACTV	0°C to +70°C	TO-99 Metal Can
ICL761XAMTV	-55°C to +125°C	TO-99 Metal Can
ICL761XBCPA	0°C to +70°C	8 Plastic Dip
ICL761XBCSA	0°C to +70°C	8 Slim SO
ICL761XBCTV	0°C to +70°C	TO-99 Metal Can
ICL761XBESA	-40°C to +85°C	8 Slim SO
ICL761XBMTV	-55°C to +125°C	TO-99 Metal Can
ICL761XDPCA	0°C to +70°C	8 Plastic Dip
ICL761XDCSA	0°C to +70°C	8 Slim SO
ICL761XDCTV	0°C to +70°C	TO-99 Metal Can
ICL761XD/C/D	0°C to +70°C	Dice
ICL761XDESA	-40°C to +85°C	8 Slim SO
ICL7621ACPA	0°C to +70°C	8 Plastic Dip
ICL7621ACSA	0°C to +70°C	8 Slim SO
ICL7621ACTV	0°C to +70°C	TO-99 Metal Can
ICL7621AMTV	-55°C to +125°C	TO-99 Metal Can
ICL7621BCPA	0°C to +70°C	8 Plastic Dip

PART	TEMP RANGE	PIN-PACKAGE
ICL7621BCSA	0°C to +70°C	8 Slim SO
ICL7621BCTV	0°C to +70°C	TO-99 Metal Can
ICL7621BMTV	-55°C to +125°C	TO-99 Metal Can
ICL7621DCPA	0°C to +70°C	8 Plastic Dip
ICL7621DCSA	0°C to +70°C	8 Slim SO
ICL7621DCTV	0°C to +70°C	TO-99 Metal Can
ICL7621DC/D	0°C to +70°C	Dice
ICL7622ACPD	0°C to +70°C	14 Plastic Dip
ICL7622ACSD	0°C to +70°C	14 Slim SO
ICL7622ACJD	0°C to +70°C	14 CERDIP
ICL7622AMJD	-55°C to +125°C	14 CERDIP
ICL7622BCPD	0°C to +70°C	14 Plastic Dip
ICL7622BCSA	0°C to +70°C	14 Slim SO
ICL7622BCJD	0°C to +70°C	14 CERDIP
ICL7622BMJD	-55°C to +125°C	14 CERDIP
ICL7622DCPD	0°C to +70°C	14 Plastic Dip
ICL7622DCSD	0°C to +70°C	14 Slim SO
ICL7622DCJD	0°C to +70°C	14 CERDIP
ICL7622DC/D	0°C to +70°C	Dice

Note: X above is replaced by: 1, 2, 4, 8.

Single/Dual/Triple/Quad Operational Amplifiers

Pin Configurations

ICL761X-ICL764X

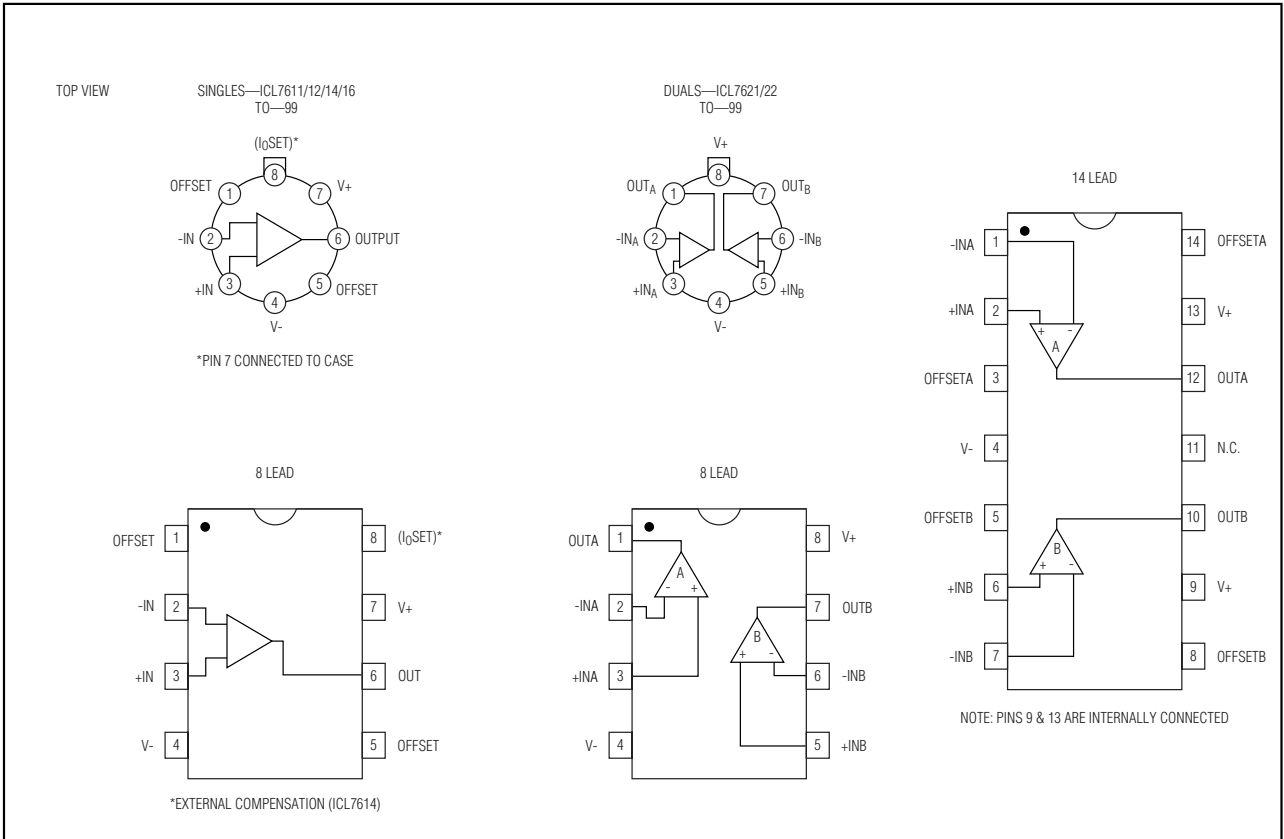

Single/Dual/Triple/Quad Operational Amplifiers

ABSOLUTE MAXIMUM RATINGS (Single/Dual)

Total Supply Voltage (V+ to V-)	+18V	16-Pin Plastic (derate 3mW/°C above +25°C)	375mW
Input Voltage	(V+ + 0.3V) to (V- - 0.3V)	16-Pin CERDIP (derate 4mW/°C above +25°C)	500mW
Differential Input Voltage (Note 1)	±(V+ + 0.3V) to (V- - 0.3V)	Operating Temperature Ranges:	
Duration of Output Short Circuit (Note 2)	Unlimited	M Series	-55°C to +125°C
Continuous Power Dissipation (T _A = +25°C)		E Series	-40°C to +85°C
TO-99 Metal Can (derate 2mW/°C above +25°C)	250mW	C Series	-0°C to +70°C
8-Pin Minidip (derate 2mW/°C above +25°C)	250mW	Storage Temperature Range	-55°C to +150°C
14-Pin Plastic (derate 3mW/°C above +25°C)	375mW	Lead Temperature (soldering, 10s)	+300°C
14-Pin CERDIP (derate 4mW/°C above +25°C)	500mW		

Stresses beyond those listed under "Absolute Maximum Ratings" may cause permanent damage to the device. These are stress ratings only, and functional operation of the device at these or any other conditions beyond those indicated in the operational sections of the specifications is not implied. Exposure to absolute maximum rating conditions for extended periods may affect device reliability.

- Note 1:** Long-term offset voltage stability will be degraded if large input differential voltages are applied for long periods of time.
Note 2: The outputs may be shorted to ground or to either supply for V_{SUPP} ≤ 10V. Care must be taken to insure that the dissipation rating is not exceeded.

ELECTRICAL CHARACTERISTICS (Single/Dual)

(V_{SUPP} = ±1.0V, I_Q = 10μA, T_A = +25°C, unless otherwise noted.)

PARAMETER	SYMBOL	CONDITIONS	ICL76XXA			ICL76XXB			UNITS
			MIN	TYP	MAX	MIN	TYP	MAX	
Input Offset Voltage	V _{OS}	R _S ≤ 100kΩ, T _A = +25°C			2			5	mV
		R _S ≤ 100kΩ, T _{MIN} ≤ T _A ≤ T _{MAX}			3			7	
Temperature Coefficient of V _{OS}	ΔV _{OS} /ΔT	R _S ≤ 100kΩ		10			15		μV/°C
Input Offset Current	I _{OS}	T _A = +25°C		0.5	30		0.5	30	pA
		0°C ≤ T _A ≤ +70°C			300			300	
Input Bias Current	I _{BIAS}	T _A = +25°C		1.0	50		1.0	50	pA
		0°C ≤ T _A ≤ +70°C			500			500	
Common-Mode Voltage Range (Except ICL7612/ICL7616)	V _{CMR}		-0.4		+0.6	-0.4		+0.6	V
Extended Common-Mode Voltage Range (ICL7612 Only)	V _{CMR}		-1.1		+0.6	-1.1		+0.6	V
Extended Common-Mode Voltage Range (ICL7616 Only)	V _{CMR}	I _Q = 10μA	-1.3		-0.3	-1.3		-0.3	V
Output Voltage Swing	V _{OUT}	R _L = 1MΩ, T _A = +25°C		±0.98			±0.98		V
		R _L = 1MΩ, 0°C ≤ T _A ≤ +70°C		±0.96			±0.96		

Single/Dual/Triple/Quad Operational Amplifiers

ICL761X-ICL764X

ELECTRICAL CHARACTERISTICS (Single/Dual) (continued)

($V_{SUPP} = \pm 1.0V$, $I_Q = 10\mu A$, $T_A = +25^\circ C$, unless otherwise noted.)

PARAMETER	SYMBOL	CONDITIONS	ICL76XXA			ICL76XXB			UNITS
			MIN	TYP	MAX	MIN	TYP	MAX	
Large-Signal Voltage Gain	A _{VOL}	V _O = ±0.1V, R _L = 1MΩ, T _A = +25°C	90			90			dB
		V _O = ±0.1V, R _L = 1MΩ, 0°C ≤ T _A ≤ +70°C	80			80			
Unity-Gain Bandwidth	GBW		0.044			0.044			MHz
Input Resistance	R _{IN}		10 ¹²			10 ¹²			Ω
Common-Mode Rejection Ratio	CMRR	R _S ≤ 100kΩ	80			80			dB
Power-Supply Rejection Ratio	PSRR	R _S ≤ 100kΩ	80			80			dB
Input-Referred Noise Voltage	e _n	R _S = 100Ω, f = 1kHz	100			100			nV/√Hz
Input-Referred Noise Current	i _n	R _S = 100Ω, f = 1kHz	0.01			0.01			pA/√Hz
Supply Current (Per Amplifier)	I _{SUPP}	No signal, no load	6	15		6	15		μA
Slew Rate	SR	A _{VOL} = 1, C _L = 100pF, V _{IN} = 0.2V _{P-P} , R _L = 1MΩ	0.016			0.016			V/μs
Rise Time	t _r	V _{IN} = 50mV, C _L = 100pF, R _L = 1MΩ	20			20			μs
Overshoot Factor		V _{IN} = 50mV, C _L = 100pF, R _L = 1MΩ	5			5			%

ELECTRICAL CHARACTERISTICS (Single/Dual)

($V_{SUPP} = \pm 5.0V$, $T_A = +25^\circ C$, unless otherwise noted.)

PARAMETER	SYMBOL	CONDITIONS	ICL76XXA			ICL76XXB			ICL76XXD			UNITS
			MIN	TYP	MAX	MIN	TYP	MAX	MIN	TYP	MAX	
Input Offset Voltage	V _{OS}	R _S ≤ 100kΩ, T _A = +25°C	2			5			15			mV
		R _S ≤ 100kΩ, T _{MIN} ≤ T _A ≤ T _{MAX}	3			7			20			
Temperature Coefficient of V _{OS}	ΔV _{OS} /ΔT	R _S ≤ 100kΩ	10			15			25			μV/°C
Input Offset Current	I _{OS}	T _A = +25°C	0.5	30		0.5	30		0.5	30		pA
		C: 0°C ≤ T _A ≤ +70°C	300			300			300			
		E: -40°C ≤ T _A ≤ +85°C	800			800			800			
		M: -55°C ≤ T _A ≤ +125°C	800			800			800			

Single/Dual/Triple/Quad Operational Amplifiers

ELECTRICAL CHARACTERISTICS (Single/Dual) (continued)

(V_{SUPP} = ±5.0V, T_A = +25°C, unless otherwise noted.)

PARAMETER	SYMBOL	CONDITIONS	ICL76XXA			ICL76XXB			ICL76XXD			UNITS
			MIN	TYP	MAX	MIN	TYP	MAX	MIN	TYP	MAX	
Input Bias Current	I _{BIAS}	T _A = +25°C	1.0	50		1.0	50		1.0	50		pA
		C: 0°C ≤ T _A ≤ +70°C			400			400			400	
		E: -40°C ≤ T _A ≤ +85°C			4000			4000			4000	
		M: -55°C ≤ T _A ≤ +125°C			4000			4000			4000	
Common-Mode Voltage Range (Except ICL7612/ICL7616)	V _{CMR}	I _Q = 10μA (Note 3)	+4.4			+4.4			+4.4			V
			-4.0			-4.0			-4.0			
		I _Q = 100μA (Note 3)	+4.2			+4.2			+4.2			
			-4.0			-4.0			-4.0			
		I _Q = 1mA (Note 3)	+3.7			+3.7			+3.7			
			-3.7			-3.7			-3.7			
Extended Common-Mode Voltage Range (ICL7612 Only)	V _{CMR}	I _Q = 10μA	±5.3			±5.3			±5.3			V
			+5.3			+5.3			+5.3			
		I _Q = 100μA	-5.1			-5.1			-5.1			
			+5.3			+5.3			+5.3			
		I _Q = 1mA	-4.5			-4.5			-4.5			
			+5.3			+5.3			+5.3			
Extended Common-Mode Voltage Range (ICL7616 Only)	V _{CMR}	I _Q = 10μA	-5.3			-5.3			-5.3			V
			+3.7			+3.7			+3.5			
		I _Q = 100μA	-5.1			-5.1			-5.1			
			+3.0			+3.0			+2.7			
		I _Q = 1mA	-4.5			-4.5			-4.5			
			+2.0			+2.0			+1.7			

Single/Dual/Triple/Quad Operational Amplifiers

ICL761X-ICL764X

ELECTRICAL CHARACTERISTICS (Single/Dual) (continued)

(V_{SUPP} = ±5.0V, T_A = +25°C, unless otherwise noted.)

PARAMETER	SYMBOL	CONDITIONS	ICL76XXA			ICL76XXB			ICL76XXD			UNITS
			MIN	TYP	MAX	MIN	TYP	MAX	MIN	TYP	MAX	
Output Voltage Swing	V _{OUT}	I _Q = 10μA, R _L = 1MΩ (Note 3)	T _A = +25°C	±4.9			±4.9			±4.9		V
			C: 0°C ≤ T _A ≤ +70°C	±4.8			±4.8			±4.8		
			E: -40°C ≤ T _A ≤ +85°C	±4.7			±4.7			±4.7		
			M: -55°C ≤ T _A ≤ +125°C	±4.7			±4.7			±4.7		
		I _Q = 100μA, R _L = 100kΩ	T _A = +25°C	±4.9			±4.9			±4.9		
			C: 0°C ≤ T _A ≤ +70°C	±4.8			±4.8			±4.8		
			E: -40°C ≤ T _A ≤ +85°C	±4.5			±4.5			±4.5		
			M: -55°C ≤ T _A ≤ +125°C	±4.5			±4.5			±4.5		
		I _Q = 1mA, R _L = 10kΩ (Note 3)	T _A = +25°C	±4.5			±4.5			±4.5		
			C: 0°C ≤ T _A ≤ +70°C	±4.3			±4.3			±4.3		
			E: -40°C ≤ T _A ≤ +85°C	±4.0			±4.0			±4.0		
			M: -55°C ≤ T _A ≤ +125°C	±4.0			±4.0			±4.0		

Single/Dual/Triple/Quad Operational Amplifiers

ELECTRICAL CHARACTERISTICS (Single/Dual) (continued)

(V_{SUPP} = ±5.0V, T_A = +25°C, unless otherwise noted.)

PARAMETER	SYMBOL	CONDITIONS	ICL76XXA			ICL76XXB			ICL76XXD			UNITS
			MIN	TYP	MAX	MIN	TYP	MAX	MIN	TYP	MAX	
Large-Signal Voltage Gain	A _{VOL}	V _O = ±4.0V R _L = 1MΩ, I _Q = 10μA	T _A = +25°C	86	104		80	104		80	104	dB
			C: 0°C ≤ T _A ≤ +70°C	80			75			75		
			E: -40°C ≤ T _A ≤ +85°C	74			68			68		
			M: -55°C ≤ T _A ≤ +125°C	74			68			68		
		V _O = ±4.0V, R _L = 100kΩ, I _Q = 100μA	T _A = +25°C	86	102		80	102		80	102	
			C: 0°C ≤ T _A ≤ +70°C	80			75			75		
			E: -40°C ≤ T _A ≤ +85°C	74			68			68		
			M: -55°C ≤ T _A ≤ +125°C	74			68			68		
		V _O = ±4.0V, R _L = 10kΩ, I _Q = 1mA (Note 3)	T _A = +25°C	80	83		76	83		76	83	
			C: 0°C ≤ T _A ≤ +70°C	76			72			72		
			E: -40°C ≤ T _A ≤ +85°C	72			68			68		
			M: -55°C ≤ T _A ≤ +125°C	72			68			68		

Single/Dual/Triple/Quad Operational Amplifiers

ICL761X-ICL764X

ELECTRICAL CHARACTERISTICS (Single/Dual) (continued)

(V_{SUPP} = ±5.0V, T_A = +25°C, unless otherwise noted.)

PARAMETER	SYMBOL	CONDITIONS	ICL76XXA			ICL76XXB			ICL76XXD			UNITS
			MIN	TYP	MAX	MIN	TYP	MAX	MIN	TYP	MAX	
Unity-Gain Bandwidth	GBW	I _Q = 10μA (Note 3)	0.044			0.044			0.044			MHz
		I _Q = 100μA	0.48			0.48			0.48			
		I _Q = 1mA (Note 3)	1.4			1.4			1.4			
Input Resistance	R _{IN}		10 ¹²			10 ¹²			10 ¹²			Ω
Common-Mode Rejection Ratio	CMRR	R _S ≤ 100kΩ, I _Q = 10μA (Note 3)	76	96		70	96		70	96		dB
		R _S ≤ 100kΩ, I _Q = 100μA	76	91		70	91		70	91		
		R _S ≤ 100kΩ, I _Q = 1mA (Note 3)	66	87		60	87		60	87		
Power-Supply Rejection Ratio	PSRR	R _S ≤ 100kΩ, I _Q = 10μA (Note 3)	80	94		80	94		80	94		dB
		R _S ≤ 100kΩ, I _Q = 100μA	80	86		80	86		80	86		
		R _S ≤ 100kΩ, I _Q = 1mA (Note 3)	70	77		70	77		70	77		
Input-Referred Noise Voltage	e _n	R _S = 100Ω, f = 1kHz	100			100			100			nV/√Hz
Input-Referred Noise Current	i _n	R _S = 100Ω, f = 1kHz	0.01			0.01			0.01			pA/√Hz
Supply Current (Per Amplifier)	I _{SUPP}	No signal, no load	I _Q = 10μA (Note 3)	0.01	0.02		0.01	0.02		0.01	0.02	mA
			I _Q = 100μA	0.1	0.25		0.1	0.25		0.1	0.25	
			I _Q = 1mA (Note 3)	1.0	2.5		1.0	2.5		1.0	2.5	
Channel Separation	V _{O1} / V _{O2}	AV _{OL} = 100	120			120			120			dB

Single/Dual/Triple/Quad Operational Amplifiers

ELECTRICAL CHARACTERISTICS (Single/Dual) (continued)

(V_{SUPP} = ±5.0V, T_A = +25°C, unless otherwise noted.)

PARAMETER	SYMBOL	CONDITIONS	ICL76XXA			ICL76XXB			ICL76XXD			UNITS	
			MIN	TYP	MAX	MIN	TYP	MAX	MIN	TYP	MAX		
Slew Rate (Note 4)	SR	A _{VOL} = 1, C _L = 100pF, V _{IN} = 8VP-P	I _Q = 10μA (Note 3), R _L = 1MΩ	0.016			0.016			0.016			V/μs
			I _Q = 100μA, R _L = 100kΩ	0.16			0.16			0.16			
			I _Q = 1mA (Note 3), R _L = 10kΩ	1.6			1.6			1.6			
Rise Time (Note 4)	t _r	V _{IN} = 50mV, C _L = 100pF	I _Q = 10μA (Note 3), R _L = 1MΩ	20			20			20			μs
			I _Q = 100μA, R _L = 100kΩ	2			2			2			
			I _Q = 1mA (Note 3), R _L = 10kΩ	0.9			0.9			0.9			
Overshoot Factor (Note 4)		V _{IN} = 50mV, C _L = 100pF	I _Q = 10μA (Note 3), R _L = 1MΩ	5			5			5			%
			I _Q = 100μA, R _L = 100kΩ	10			10			10			
			I _Q = 1mA (Note 3), R _L = 10kΩ	40			40			40			

Note 3: ICL7611, ICL7612, ICL7616 only.

Note 4: ICL7814; 39pF from pin 6 to pin 8.

Single/Dual/Triple/Quad Operational Amplifiers

ICL761X-ICL764X

Ordering Information (Triple/Quad)

PART	TEMP RANGE	PIN-PACKAGE
ICL763XBCPE	0°C to +70°C	16 Plastic Dip
ICL763XBCSE	0°C to +70°C	16 Slim SO
ICL763XCCPE	0°C to +70°C	16 Plastic Dip
ICL763XCCSE	0°C to +70°C	16 Slim SO
ICL763XECPE	0°C to +70°C	16 Plastic Dip
ICL763XECSE	0°C to +70°C	16 Slim SO
ICL763XBCJE	0°C to +70°C	16 CERDIP
ICL763XCCJE	0°C to +70°C	16 CERDIP
ICL763XECJE	0°C to +70°C	16 CERDIP
ICL763XBMJE	-55°C to +125°C	16 CERDIP
ICL763XCMJE	-55°C to +125°C	16 CERDIP
ICL763XEC/D	0°C to +70°C	Dice

PART	TEMP RANGE	PIN-PACKAGE
ICL764XBCPD	0°C to +70°C	14 Plastic Dip
ICL764XBCWE	0°C to +70°C	16 Wide SO
ICL764XCCPD	0°C to +70°C	14 Plastic Dip
ICL764XCCWE	0°C to +70°C	16 Wide SO
ICL764XECPD	0°C to +70°C	14 Plastic Dip
ICL764XECWE	0°C to +70°C	16 Wide SO
ICL764XBCJD	0°C to +70°C	14 CERDIP
ICL764XCCJD	0°C to +70°C	14 CERDIP
ICL764XECJD	0°C to +70°C	14 CERDIP
ICL764XBMJD	-55°C to +125°C	14 CERDIP
ICL764XCMJD	-55°C to +125°C	14 CERDIP
ICL764XEC/D	0°C to +70°C	Dice

Note: X above is replaced by 1, 2.

Pin Configurations

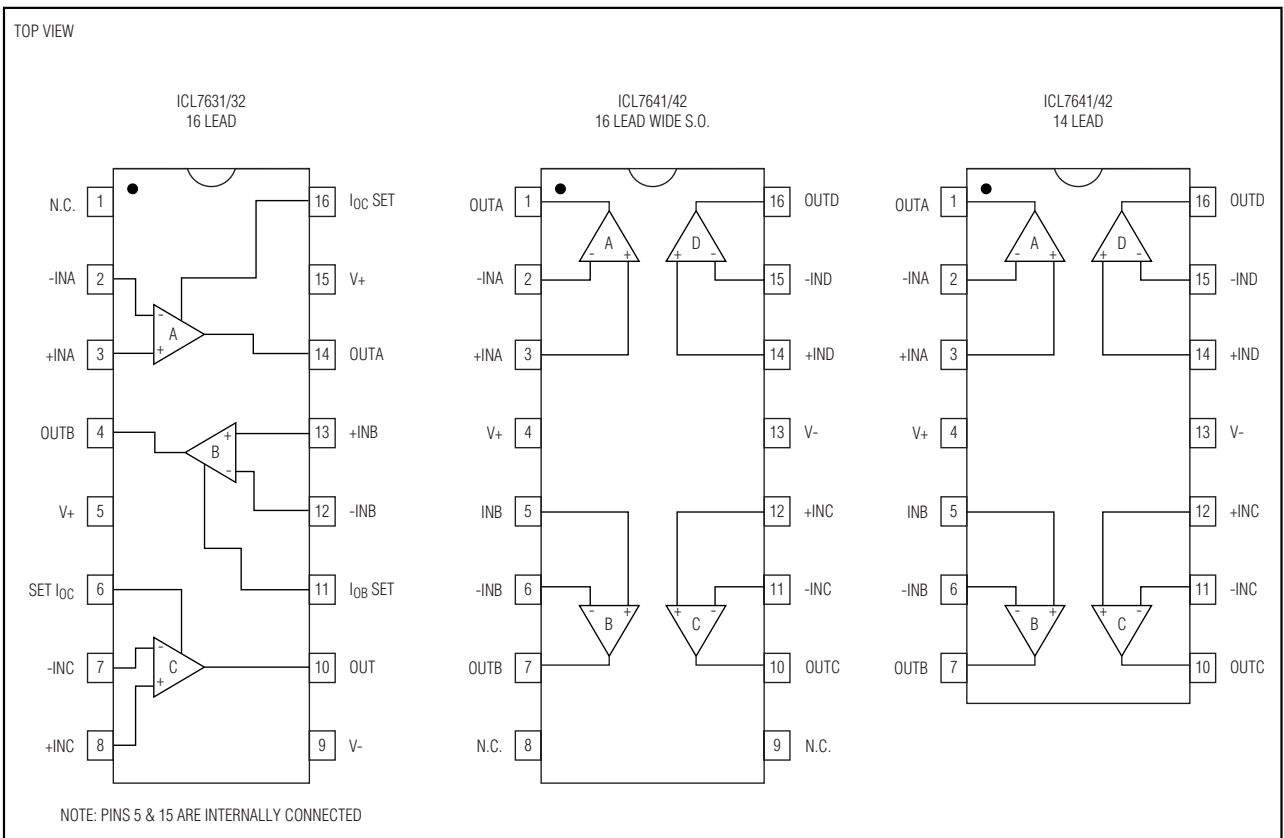

Single/Dual/Triple/Quad Operational Amplifiers

ABSOLUTE MAXIMUM RATINGS (Triple/Quad)

Total Supply Voltage (V+ to V-)+18V	16-Pin Plastic (derate 3mW/°C above +25°C)375mW
Input Voltage(V+ + 0.3V) to (V- - 0.3V)	16-Pin CERDIP (derate 4mW/°C above +25°C)500mW
Differential Input Voltage (Note 5)±I(V+ + 0.3V) - (V- - 0.3V)	Operating Temperature Ranges:	
Duration of Output Short Circuit (Note 6)Unlimited	M Series-55°C to +125°C
Continuous Power Dissipation (T _A = +25°C)		E Series-40°C to +85°C
TO-99 Metal Can (derate 2mW/°C above +25°C)250mW	C Series-0°C to +70°C
8-Pin Minidip (derate 2mW/°C above +25°C)250mW	Storage Temperature Range-55°C to +150°C
14-Pin Plastic (derate 3mW/°C above +25°C)375mW	Lead Temperature (soldering, 10s)+300°C
14-Pin CERDIP (derate 4mW/°C above +25°C)500mW		

Stresses beyond those listed under "Absolute Maximum Ratings" may cause permanent damage to the device. These are stress ratings only, and functional operation of the device at these or any other conditions beyond those indicated in the operational sections of the specifications is not implied. Exposure to absolute maximum rating conditions for extended periods may affect device reliability.

Note 5: Long-term offset voltage stability will be degraded if large input differential voltages are applied for long periods of time.

Note 6: The outputs may be shorted to ground or to either supply for V_{SUPP} ≤ 10V. Care must be taken to insure that the dissipation rating is not exceeded.

ELECTRICAL CHARACTERISTICS (Triple/Quad)

(V_{SUPP} = ±1.0V, I_Q = 10µA, T_A = +25°C, unless otherwise noted.) (Specifications apply to ICL7631/7632/7642 only.)

PARAMETER	SYMBOL	CONDITIONS	ICL76XXB			ICL76XXC			UNITS
			MIN	TYP	MAX	MIN	TYP	MAX	
Input Offset Voltage	V _{OS}	R _S ≤ 100kΩ, T _A = +25°C			5			10	mV
		R _S ≤ 100kΩ, T _{MIN} ≤ T _A ≤ T _{MAX}			7			12	
Temperature Coefficient of V _{OS}	ΔV _{OS} /ΔT	R _S ≤ 100kΩ		15			20		µV/°C
Input Offset Current	I _{OS}	T _A = +25°C		0.5	30		0.5	30	pA
		0°C ≤ T _A ≤ +70°C			300			300	
Input Bias Current	I _{BIAS}	T _A = +25°C		1.0	50		1.0	50	pA
		0°C ≤ T _A ≤ +70°C			500			500	
Common-Mode Voltage Range	V _{CMR}		-0.4		+0.6	-0.4		+0.6	V
Output Voltage Swing	V _{OUT}	R _L = 1MΩ, T _A = +25°C		±0.98			±0.98		V
		R _L = 1MΩ, 0°C ≤ T _A ≤ +70°C		±0.96			±0.96		
Large-Signal Voltage Gain	A _{VOL}	V _O = ±0.1V, R _L = 1MΩ, T _A = +25°C		90			90		dB
		V _O = ±0.1V, R _L = 1MΩ, 0°C ≤ T _A ≤ +70°C		80			80		
Unity-Gain Bandwidth	GBW			0.044			0.044		MHz
Input Resistance	R _{IN}			10 ¹²			10 ¹²		Ω
Common-Mode Rejection Ratio	CMRR	R _S ≤ 100kΩ		80			80		dB

Single/Dual/Triple/Quad Operational Amplifiers

ICL761X-ICL764X

ELECTRICAL CHARACTERISTICS (Triple/Quad) (continued)

(V_{SUPP} = ±1.0V, I_Q = 10μA, T_A = +25°C, unless otherwise noted.) (Specifications apply to ICL7631/7632/7642 only.)

PARAMETER	SYMBOL	CONDITIONS	ICL76XXB			ICL76XXC			UNITS
			MIN	TYP	MAX	MIN	TYP	MAX	
Power-Supply Rejection Ratio	PSRR			80			80		dB
Input-Referred Noise Voltage	e _n	R _S = 100Ω, f = 1kHz		100			100		nV/√Hz
Input-Referred Noise Current	i _n	R _S = 100Ω, f = 1kHz		0.01			0.01		pA/√Hz
Supply Current (Per Amplifier)	I _{SUPP}	No signal, no load		6	15		6	15	μA
Channel Separation	V _{O1} / V _{O2}	A _{VOL} = 100		120			120		dB
Slew Rate	SR	A _{VOL} = 1, C _L = 100pF, V _{IN} = 0.2V _{P-P} , R _L = 1MΩ		0.016			0.016		V/μs
Rise Time	t _r	V _{IN} = 50mV, C _L = 100pF, R _L = 1MΩ		20			20		μs
Overshoot Factor		V _{IN} = 50mV, C _L = 100pF, R _L = 1MΩ		5			5		%

ELECTRICAL CHARACTERISTICS (Triple/Quad)

(V_{SUPP} = ±5.0V, T_A = +25°C, unless otherwise noted.)

PARAMETER	SYMBOL	CONDITIONS	ICL76XXA			ICL76XXB			ICL76XXD			UNITS
			MIN	TYP	MAX	MIN	TYP	MAX	MIN	TYP	MAX	
Input Offset Voltage	V _{OS}	R _S ≤ 100kΩ, T _A = +25°C		5			10			20	mV	
		R _S ≤ 100kΩ, T _{MIN} ≤ T _A ≤ T _{MAX}		7			15			25		
Temperature Coefficient of V _{OS}	ΔV _{OS} /ΔT	R _S ≤ 100kΩ		15			20			30	μV/°C	
Input Offset Current	I _{OS}	T _A = +25°C		0.5	30		0.5	30		0.5	30	pA
		C: 0°C ≤ T _A ≤ +70°C		300			300			300		
		M: -55°C ≤ T _A ≤ +125°C		800			800			800		
Input Bias Current	I _{BIAS}	T _A = +25°C		1.0	50		1.0	50		1.0	50	pA
		C: 0°C ≤ T _A ≤ +70°C		500			500			500		
		M: -55°C ≤ T _A ≤ +125°C		4000			4000			4000		

Single/Dual/Triple/Quad Operational Amplifiers

ELECTRICAL CHARACTERISTICS (Triple/Quad) (continued)

(V_{SUPP} = ±5.0V, T_A = +25°C, unless otherwise noted.)

PARAMETER	SYMBOL	CONDITIONS	ICL76XXA			ICL76XXB			ICL76XXD			UNITS	
			MIN	TYP	MAX	MIN	TYP	MAX	MIN	TYP	MAX		
Common-Mode Voltage Range	V _{CMR}	I _Q = 10μA (Note 7)	+4.4			+4.4			+4.4			V	
			-4.0			-4.0			-4.0				
		I _Q = 100μA (Note 9)	+4.2			+4.2			+4.2				
			-4.0			-4.0			-4.0				
		I _Q = 1mA (Note 8)	+3.7			+3.7			+3.7				
			-3.7			-3.7			-3.7				
Output Voltage Swing	V _{OUT}	I _Q = 10μA, R _L = 1MΩ (Note 7)	T _A = +25°C	±4.9			±4.9			±4.9			V
			C: 0°C ≤ T _A ≤ +70°C	±4.8			±4.8			±4.8			
			M: -55°C ≤ T _A ≤ +125°C	±4.7			±4.7			±4.7			
		I _Q = 100μA, R _L = 100kΩ (Note 9)	T _A = +25°C	±4.9			±4.9			±4.9			
			C: 0°C ≤ T _A ≤ +70°C	±4.8			±4.8			±4.8			
			M: -55°C ≤ T _A ≤ +125°C	±4.5			±4.5			±4.5			
		I _Q = 1mA, R _L = 10kΩ (Note 8)	T _A = +25°C	±4.5			±4.5			±4.5			
			C: 0°C ≤ T _A ≤ +70°C	±4.3			±4.3			±4.3			
			M: -55°C ≤ T _A ≤ +125°C	±4.0			±4.0			±4.0			

Single/Dual/Triple/Quad Operational Amplifiers

ICL761X-ICL764X

ELECTRICAL CHARACTERISTICS (Triple/Quad) (continued)

(V_{SUPP} = ±5.0V, T_A = +25°C, unless otherwise noted.)

PARAMETER	SYMBOL	CONDITIONS	ICL76XXA			ICL76XXB			ICL76XXD			UNITS
			MIN	TYP	MAX	MIN	TYP	MAX	MIN	TYP	MAX	
Large-Signal Voltage Gain	A _{VOL}	V _O = ±4.0V, R _L = 1MΩ, I _Q = 10μA (Note 7)	T _A = +25°C	86	104		80	104		80	104	dB
			C: 0°C ≤ T _A ≤ +70°C	80			75			75		
			M: -55°C ≤ T _A ≤ +125°C	74			68			68		
		V _O = ±4.0V, R _L = 100kΩ, I _Q = 100μA	T _A = +25°C	86	102		80	102		80	102	
			C: 0°C ≤ T _A ≤ +70°C	80			75			75		
			M: -55°C ≤ T _A ≤ +125°C	74			68			68		
		V _O = ±4.0V, R _L = 10kΩ (Note 8), I _Q = 1mA (Note 7)	T _A = +25°C	86	98		80	98		80	98	
			C: 0°C ≤ T _A ≤ +70°C	80			75			75		
			M: -55°C ≤ T _A ≤ +125°C	74			68			68		

Single/Dual/Triple/Quad Operational Amplifiers

ELECTRICAL CHARACTERISTICS (Triple/Quad) (continued)

(V_{SUPP} = ±5.0V, T_A = +25°C, unless otherwise noted.)

PARAMETER	SYMBOL	CONDITIONS	ICL76XXA			ICL76XXB			ICL76XXD			UNITS	
			MIN	TYP	MAX	MIN	TYP	MAX	MIN	TYP	MAX		
Unity-Gain Bandwidth	GBW	I _Q = 10μA (Note 7)	0.044			0.044			0.044			MHz	
		I _Q = 100μA (Note 9)	0.48			0.48			0.48				
		I _Q = 1mA (Note 8)	1.4			1.4			1.4				
Input Resistance	R _{IN}		10 ¹²			10 ¹²			10 ¹²			Ω	
Common-Mode Rejection Ratio	CMRR	R _S ≤ 100kΩ, I _Q = 10μA (Note 7)	76	96		70	96		70	96		dB	
		R _S ≤ 100kΩ, I _Q = 100μA	76	91		70	91		70	91			
		R _S ≤ 100kΩ, I _Q = 1mA (Note 8)	66	87		60	87		60	87			
Power-Supply Rejection Ratio	PSRR	R _S ≤ 100kΩ, I _Q = 10μA (Note 7)	80	94		80	94		80	94		dB	
		R _S ≤ 100kΩ, I _Q = 100μA	80	86		80	86		80	86			
		R _S ≤ 100kΩ, I _Q = 1mA (Note 8)	70	77		70	77		70	77			
Input-Referred Noise Voltage	e _n	R _S = 100Ω, f = 1kHz	100			100			100			nV/√Hz	
Input-Referred Noise Current	i _n	R _S = 100Ω, f = 1kHz	0.01			0.01			0.01			pA/√Hz	
Supply Current (Per Amplifier)	I _{SUPP}	No signal, no load	I _Q = 10μA (Note 7)	0.01	0.022		0.01	0.022		0.01	0.022	mA	
			I _Q = 100μA	0.1	0.25		0.1	0.25		0.1	0.25		
			I _Q = 1mA (Note 8)	1.0	2.5		1.0	2.5		1.0	2.5		
Channel Separation	V _{O1} / V _{O2}	A _{VOL} = 100	120			120			120			dB	
Slew Rate (Note 10)	SR	A _{VOL} = 1, C _L = 100pF, V _{IN} = 8VP-P	I _Q = 10μA (Note 7), R _L = 1MΩ	0.016			0.016			0.016			V/μs
			I _Q = 100μA, R _L = 100kΩ	0.16			0.16			0.16			
			I _Q = 1mA (Note 7), R _L = 10kΩ	1.6			1.6			1.6			

Single/Dual/Triple/Quad Operational Amplifiers

ICL761X-ICL764X

ELECTRICAL CHARACTERISTICS (Triple/Quad) (continued)

($V_{SUPP} = \pm 5.0V$, $T_A = +25^\circ C$, unless otherwise noted.)

PARAMETER	SYMBOL	CONDITIONS	ICL76XXA			ICL76XXB			ICL76XXD			UNITS	
			MIN	TYP	MAX	MIN	TYP	MAX	MIN	TYP	MAX		
Rise Time (Note 10)	t_r	$V_{IN} = 50mV$, $C_L = 100pF$	$I_Q = 10\mu A$ (Note 7), $R_L = 1M\Omega$	20			20			20			μs
			$I_Q = 100\mu A$, $R_L = 100k\Omega$	2			2			2			
			$I_Q = 1mA$ (Note 8), $R_L = 10k\Omega$	0.9			0.9			0.9			
Overshoot Factor (Note 10)		$V_{IN} = 50mV$, $C_L = 100pF$	$I_Q = 10\mu A$ (Note 7), $R_L = 1M\Omega$	5			5			5			%
			$I_Q = 100\mu A$, $R_L = 100k\Omega$	10			10			10			
			$I_Q = 1mA$ (Note 8), $R_L = 10k\Omega$	40			40			40			

Note 7: Does not apply to ICL7641.

Note 8: Does not apply to ICL7642.

Note 9: ICL7631/ICL7632 only.

Note 10: Does not apply to ICL7632.

Typical Operating Characteristics

($T_A = +25^\circ C$, unless otherwise noted.)

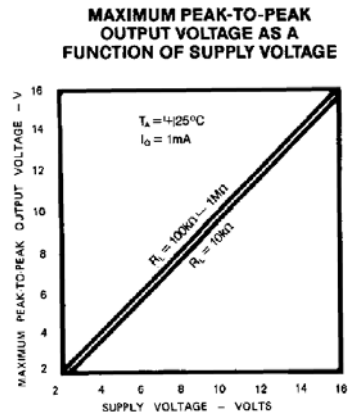
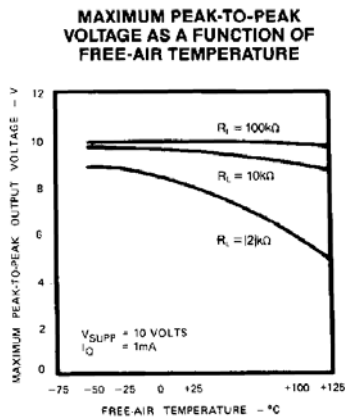

Single/Dual/Triple/Quad Operational Amplifiers

Typical Operating Characteristics (continued)

($T_A = +25^\circ\text{C}$, unless otherwise noted.)

SUPPLY CURRENT PER AMPLIFIER AS A FUNCTION OF SUPPLY VOLTAGE

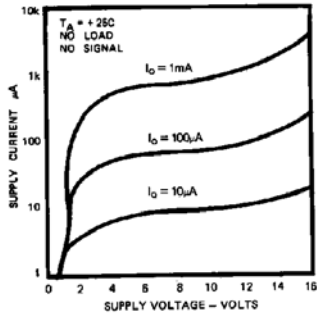

PEAK-TO-PEAK OUTPUT VOLTAGE AS A FUNCTION OF FREQUENCY

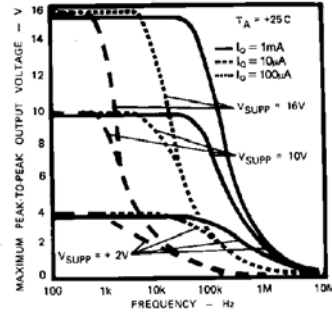

POWER SUPPLY REJECTION RATIO AS A FUNCTION OF FREE-AIR TEMPERATURE

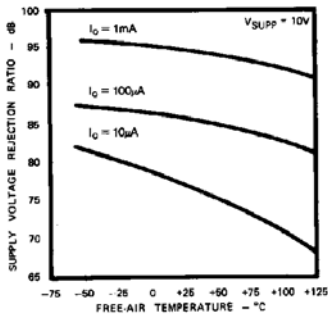

LARGE SIGNAL DIFFERENTIAL VOLTAGE GAIN AS A FUNCTION OF FREE-AIR TEMPERATURE

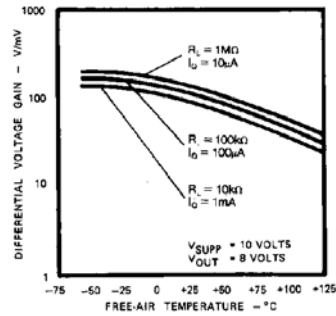

LARGE SIGNAL DIFFERENTIAL VOLTAGE GAIN AND PHASE SHIFT AS A FUNCTION OF FREQUENCY

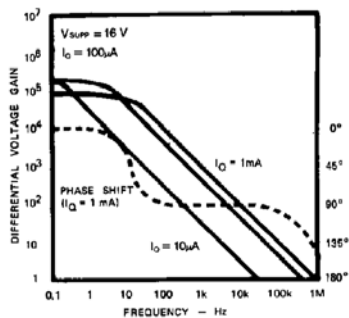

MAXIMUM OUTPUT SINK CURRENT AS A FUNCTION OF SUPPLY VOLTAGE

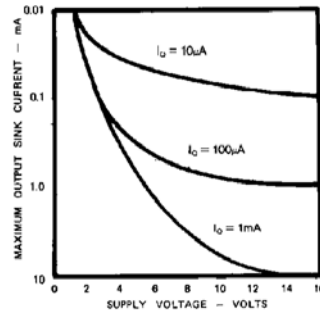

Single/Dual/Triple/Quad Operational Amplifiers

ICL761X-ICL764X

Typical Operating Characteristics (continued)

($T_A = +25^\circ\text{C}$, unless otherwise noted.)

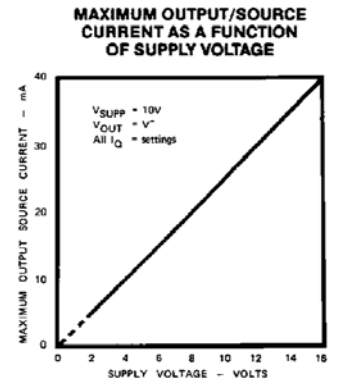
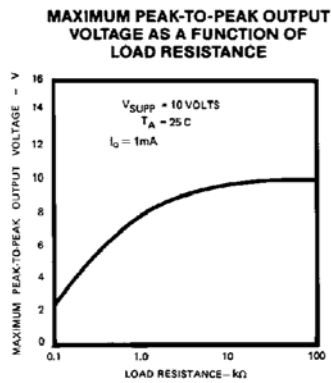
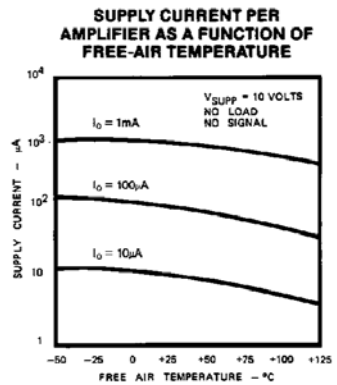
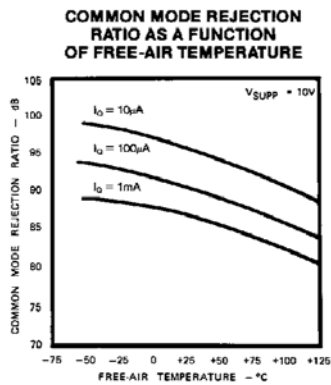
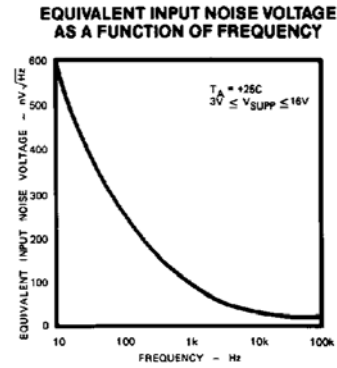
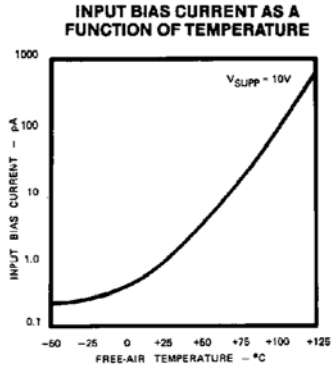

Single/Dual/Triple/Quad Operational Amplifiers

Typical Operating Characteristics (continued)

($T_A = +25^\circ\text{C}$, unless otherwise noted.)

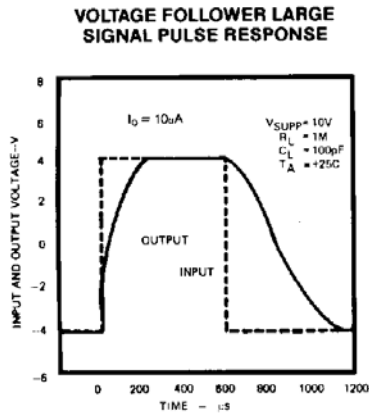
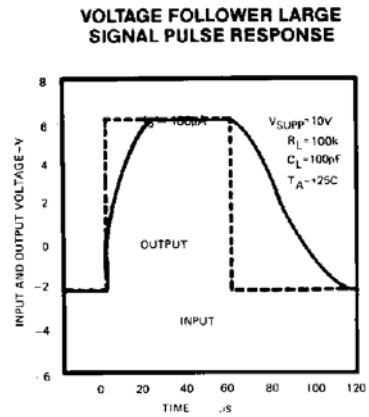
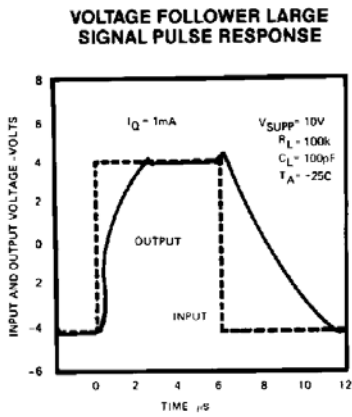

Single/Dual/Triple/Quad Operational Amplifiers

Detailed Description

Quiescent Current Selection

The voltage input to the I_Q pin of the single and triple amplifiers selects a quiescent current (I_Q) of 10μA, 100μA, or 1000μA. The dual and quad amplifiers have fixed quiescent current (I_Q) settings. Unity-gain bandwidth and slew-rate increase with increasing quiescent current, as does output sink current capability. The output source current capability is independent of quiescent current.

The lowest I_Q setting that results in sufficient bandwidth and slew rate should be selected for each specific application.

The I_Q pin of the single and triple amplifiers controls the quiescent current as follows:

- I_Q = 10μA I_Q pin to V+
- I_Q = 100μA I_Q pin between V- + 0.8V and V+ - 0.8V
- I_Q = 1mA I_Q pin to V-

Input Offset Nulling

The input offset can be nulled by connecting a 25kΩ pot between the OFFSET terminals with the wiper connected to V+. At quiescent currents of 1mA and 100μA, the nulling range provided is adequate for all V_{OS} selections. However, with higher values of V_{OS}, and an I_Q of 10μA, nulling may not be possible.

Frequency Compensation

All of the ICL7611 and ICL7621 series except the ICL7614 are internally compensated for unity-gain operation. The ICL7614 is externally compensated by a capacitor connected between COMP and OUT pins, with 39pF being greater than unity. The compensation capacitor value may be reduced to increase the bandwidth and slew rate. The ICL7132 is not compensated and does not have frequency compensation pins. Use only at gains 20 at I_Q of 1mA; at gains > 10 at I_Q of 100μA; at gain > 5 at I_Q of 10μA.

Output Loading Considerations

Approximately 70% of the amplifier's quiescent current flows in the output stage. The output swing can approach the supply rails for output loads of 1MΩ, 100kΩ, and 10kΩ, using the output stage in a highly

linear Class A mode. Crossover distortion is avoided and the voltage gain is maximized in this mode. The output stage, however, can also be operated in Class AB, which supplies higher output currents (see the *Typical Operating Characteristics*). The voltage gain decreases and the output transfer characteristic is non-linear during the transition from Class A to Class B operation.

The output stage, with a gain that is directly proportional to load impedance, approximates a transconductance amplifier. Approximately the same open-loop gains are obtained at each of the I_Q settings if corresponding loads of 10kΩ, 100kΩ, and 1MΩ are used.

The maximum output source current is higher than the maximum sink current, and is independent of I_Q.

Like most amplifiers, there are output loads for which the amplifier stability is not guaranteed. In particular, avoid capacitive loads greater than 100pF; and while on the 1mA I_Q setting, avoid loads less than 5kΩ. Since the output stage is a transconductance output, very large (>10μF) capacitive loads will create a dominant pole and the output will be stable, even with loads that are less than 5kΩ.

Extended Common-Mode Voltage Range (ICL7612/ICL7616)

A common-mode voltage range that includes both V+ and V- is often desirable, especially in single-supply operation. The ICL7612/ICL7616 extended common-mode range op amps are designed specifically to meet this need. The ICL7612 input common-mode voltage range (CMVR) extends beyond both power-supply rails when operated with at least 3V total supply and an I_Q of 10μA or 100μA. The ICL7616 CMVR includes the negative supply voltage (or ground when operated with a single supply) at an I_Q or 10μA or 100μA.

PC Board Layout

Careful PC board layout techniques must be used to take full advantage of the very low bias current of the ICL7611 family. The inputs should be encircled with a low-impedance trace, or guard, that is at the same potential as the inputs. In an inverting amplifier, this is normally ground; in a unity-gain buffer connect the guard to the output. A convenient way of guarding the 8-pin TO-99 version of the ICL7611 is to use a 10-pin circle, with the two extra pads on either side of the input pins to provide space for a guard ring (see Figure 8). Assembled boards should be carefully cleaned,

Single/Dual/Triple/Quad Operational Amplifiers

and if a high humidity environment is expected, conformally coated.

Single-Supply Operation

The ICL7611 family will operate from a single 2V to 16V power supply. The common-mode voltage range of the standard amplifier types when operated from a single supply is 1.0V to (V+ - 0.6V) at 10µA I_Q. At 100µA I_Q, the CMVR is 1.0V to (V+ - 0.8V), and at 1mA I_Q, the CMVR is 1.3V to (V+ - 1.3V). If this CMVR range is insufficient, use the ICL7612, whose CMVR includes both ground and V+, or the ICL7616, whose CMVR includes ground.

A convenient way to generate a psuedo-ground at V+/2 is to use one op amp of a quad to buffer a V+/2 voltage from a high-impedance resistive divider.

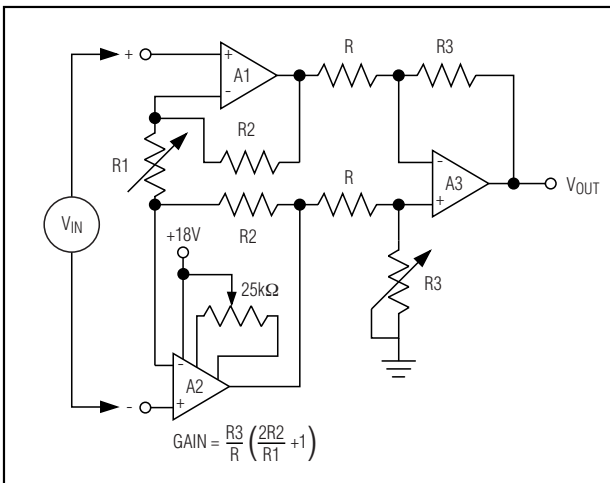

Figure 1. Instrumentation Amplifier—Adjust R3 to improve CMRR. The offset of all three amplifiers is nulled by the offset adjustment of A2.

Low-Voltage Operation

Operation at V_{SUPP} = ±1.0V is only guaranteed at I_Q = 10µA. Output swings to within a few millivolts of the supply rails are achievable for R_L (> or =) 1MΩ. Guaranteed input CMVR is ±0.6V minimum and typically +0.9V to -0.7V at V_{SUPP} = ±1.0V. For applications where greater common-mode range is desirable, see the description of ICL7612 and ICL7616 above.

Applications Information

Note that in no case is I_Q shown. The value of I_Q must be chosen by the designer with regard to frequency response and power dissipation.

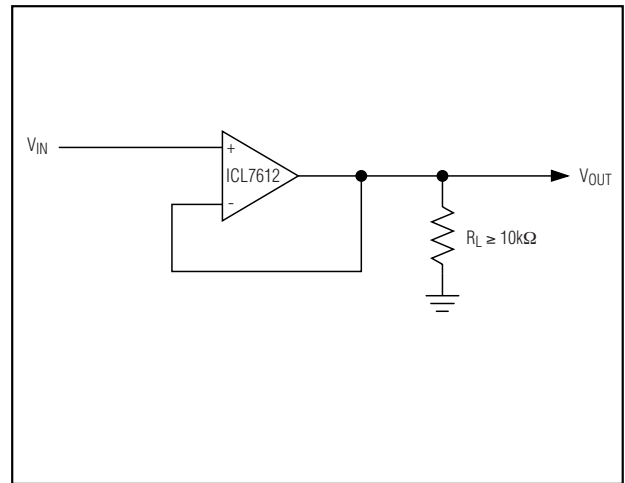

Figure 2. Simple Follower—By using the ICL7612 in these applications, the circuits will follow rail-to-rail inputs

Single/Dual/Triple/Quad Operational Amplifiers

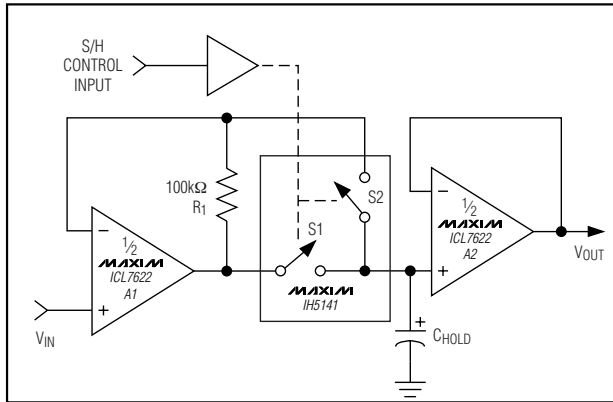

Figure 9. Low Droop Rate Sample and Hold—S2 improves accuracy and acquisition time by including the voltage drop across S1 inside the feedback loop. R1 closes the feedback loop of A1 during the hold phase. The droop rate is $[I_{BIAS}(A2) + I_{LEAK}(S1) + I_{LEAK}(S2)]/C_{HOLD}$.

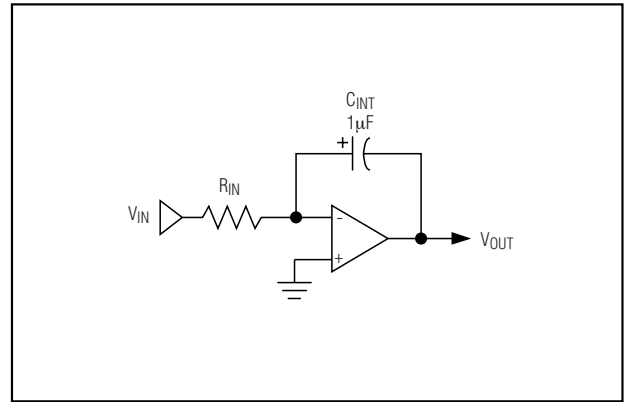

Figure 10. Long-Time Constant Integrator—With $R_{IN} = 1011\Omega$, the time constant of this integrator is 100,000s. Since the input voltage is converted to a current by R_{IN} , the input voltage can far exceed the power-supply range.

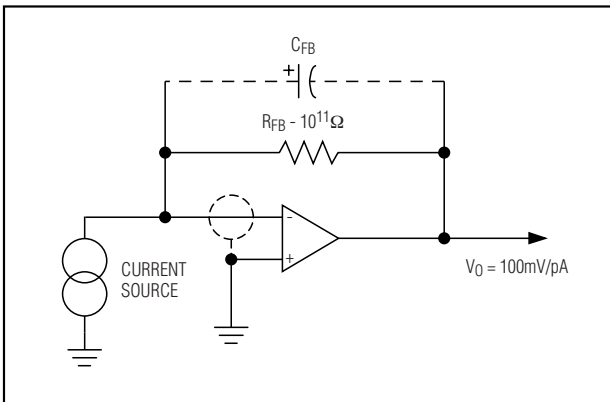

Figure 11. Pico Ammeter—The response time of this circuit is $R_{FB} \times C_{FB}$, where C_{FB} is the stray capacitance between the output and the inverting terminal of the amplifier.

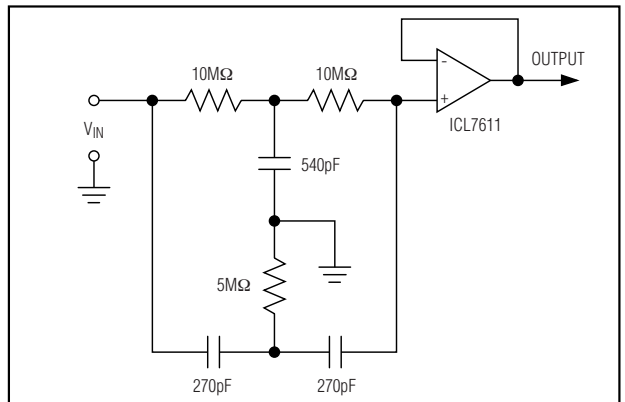
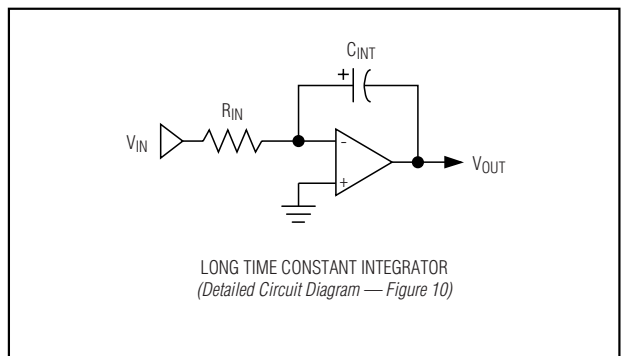

Figure 12. 60Hz Twin "T" Notch Filter—The low 1pA bias current of the ICL7611 allows use of small 540pF and 270pF capacitors, even with a notch frequency of 60Hz. The 60Hz rejection is approximately 40dB.

Typical Operating Circuit



Single/Dual/Triple/Quad Operational Amplifiers

Chip Topographies

ICL761X-ICL764X

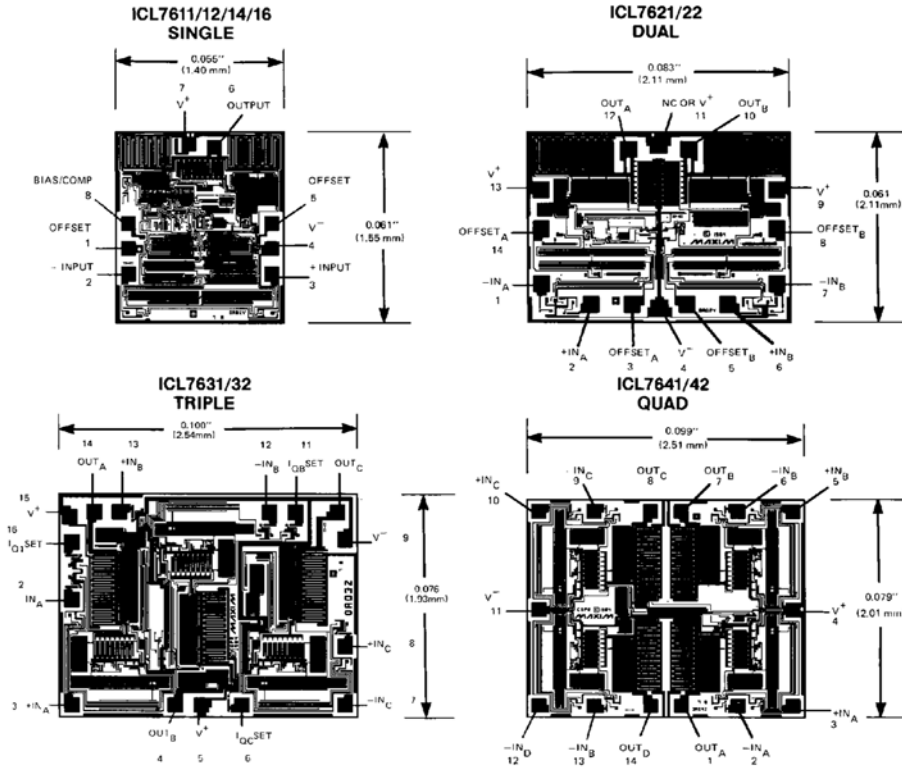

Package Information (continued)

(The package drawing(s) in this data sheet may not reflect the most current specifications. For the latest package outline information go to www.maxim-ic.com/packages.)

Revision History

Pages changed at Rev 1: 1-25

Maxim cannot assume responsibility for use of any circuitry other than circuitry entirely embodied in a Maxim product. No circuit patent licenses are implied. Maxim reserves the right to change the circuitry and specifications without notice at any time.

Maxim Integrated Products, 120 San Gabriel Drive, Sunnyvale, CA 94086 408-737-7600 _____ 25

© 2006 Maxim Integrated Products

MAXIM is a registered trademark of Maxim Integrated Products, Inc.

SITE
SEARCHPART NO.
SEARCH

WHAT'S NEW

PRODUCTS

SOLUTIONS

DESIGN

APPNOTES

SUPPORT

BUY

COMPANY

MEMBERS

Maxim > Products > Amplifiers and Comparators

ICL7611, ICL7612, ICL7614, ICL7616, ICL7621, ICL7622, ICL7624, ICL7631, ICL7632, ICL7634, ICL7641, ICL7642

Single/Dual/Triple/Quad Operational Amplifiers

QuickView

Technical Documents

Ordering Info

More Information

All

Ordering Information

Notes:

- Other options and links for purchasing parts are listed at: <http://www.maxim-ic.com/sales>.
- Didn't Find What You Need?** Ask our applications engineers. Expert assistance in finding parts, usually within one business day.
- Part number suffixes: T or T&R = tape and reel; + = RoHS/lead-free; # = RoHS/lead-exempt. More: See [Full Data Sheet](#) or [Part Naming Conventions](#).
- * Some packages have variations, listed on the drawing. "PkgCode/Variation" tells which variation the product uses.

Devices: 1-176 of 176

ICL7611	Free Sample	Buy	Package: TYPE PINS FOOTPRINT DRAWING CODE/VAR *	Temp	RoHS/Lead-Free? Materials Analysis
ICL7611DC/D					RoHS/Lead-Free: See data sheet
ICL7611BC/D					RoHS/Lead-Free: See data sheet
ICL7611DCTV			Metal Can-TO;8 pin;88 mm Dwg: 21-0022A (PDF) Use pkgcode/variation: T99-8*	0C to +70C	RoHS/Lead-Free: No Materials Analysis
ICL7611BCTV			Metal Can-TO;8 pin;88 mm Dwg: 21-0022A (PDF) Use pkgcode/variation: T99-8*	0C to +70C	RoHS/Lead-Free: No Materials Analysis
ICL7611AMTV			Metal Can-TO;8 pin;88 mm Dwg: 21-0022A (PDF) Use pkgcode/variation: T99-8*	-55C to +125C	RoHS/Lead-Free: No Materials Analysis
ICL7611DMTV			Metal Can-TO;8 pin;88 mm Dwg: 21-0022A (PDF) Use pkgcode/variation: T99-8*	-55C to +125C	RoHS/Lead-Free: No Materials Analysis
ICL7611BMTV			Metal Can-TO;8 pin;88 mm Dwg: 21-0022A (PDF) Use pkgcode/variation: T99-8*	-55C to +125C	RoHS/Lead-Free: No Materials Analysis
ICL7611BCPA+			PDIP;8 pin;82 mm Dwg: 21-0043D (PDF) Use pkgcode/variation: P8+1*	0C to +70C	RoHS/Lead-Free: Lead Free Materials Analysis
ICL7611DCPA			PDIP;8 pin;82 mm Dwg: 21-0043D (PDF) Use pkgcode/variation: P8-1*	0C to +70C	RoHS/Lead-Free: No Materials Analysis
ICL7611ACPA			PDIP;8 pin;82 mm Dwg: 21-0043D (PDF) Use pkgcode/variation: P8-1*	0C to +70C	RoHS/Lead-Free: No Materials Analysis
ICL7611ACPA+			PDIP;8 pin;82 mm Dwg: 21-0043D (PDF) Use pkgcode/variation: P8+1*	0C to +70C	RoHS/Lead-Free: Lead Free Materials Analysis
ICL7611BCPA			PDIP;8 pin;82 mm Dwg: 21-0043D (PDF) Use pkgcode/variation: P8-1*	0C to +70C	RoHS/Lead-Free: No Materials Analysis

ICL7611DCPA+			PDIP;8 pin;82 mm Dwg: 21-0043D (PDF) Use pkgcode/variation: P8+1*	0C to +70C	RoHS/Lead-Free: Lead Free Materials Analysis
ICL7611DCSA+			SOIC;8 pin;31 mm Dwg: 21-0041B (PDF) Use pkgcode/variation: S8+2*	0C to +70C	RoHS/Lead-Free: Lead Free Materials Analysis
ICL7611DCSA+T			SOIC;8 pin;31 mm Dwg: 21-0041B (PDF) Use pkgcode/variation: S8+2*	0C to +70C	RoHS/Lead-Free: Lead Free Materials Analysis
ICL7611BCSA+T			SOIC;8 pin;31 mm Dwg: 21-0041B (PDF) Use pkgcode/variation: S8+2*	0C to +70C	RoHS/Lead-Free: Lead Free Materials Analysis
ICL7611DCSA-T			SOIC;8 pin;31 mm Dwg: 21-0041B (PDF) Use pkgcode/variation: S8-2*	0C to +70C	RoHS/Lead-Free: No Materials Analysis
ICL7611DCSA			SOIC;8 pin;31 mm Dwg: 21-0041B (PDF) Use pkgcode/variation: S8-2*	0C to +70C	RoHS/Lead-Free: No Materials Analysis
ICL7611BCSA-T			SOIC;8 pin;31 mm Dwg: 21-0041B (PDF) Use pkgcode/variation: S8-2*	0C to +70C	RoHS/Lead-Free: No Materials Analysis
ICL7611BCSA			SOIC;8 pin;31 mm Dwg: 21-0041B (PDF) Use pkgcode/variation: S8-2*	0C to +70C	RoHS/Lead-Free: No Materials Analysis
ICL7611ACSA-T			SOIC;8 pin;31 mm Dwg: 21-0041B (PDF) Use pkgcode/variation: S8-2*	0C to +70C	RoHS/Lead-Free: No Materials Analysis
ICL7611ACSA			SOIC;8 pin;31 mm Dwg: 21-0041B (PDF) Use pkgcode/variation: S8-2*	0C to +70C	RoHS/Lead-Free: No Materials Analysis
ICL7611BCSA+			SOIC;8 pin;31 mm Dwg: 21-0041B (PDF) Use pkgcode/variation: S8+2*	0C to +70C	RoHS/Lead-Free: Lead Free Materials Analysis
ICL7611DESA+			SOIC;8 pin;31 mm Dwg: 21-0041B (PDF) Use pkgcode/variation: S8+2*	-40C to +85C	RoHS/Lead-Free: Lead Free Materials Analysis
ICL7611DESA+T			SOIC;8 pin;31 mm Dwg: 21-0041B (PDF) Use pkgcode/variation: S8+2*	-40C to +85C	RoHS/Lead-Free: Lead Free Materials Analysis
ICL7611DESA			SOIC;8 pin;31 mm Dwg: 21-0041B (PDF) Use pkgcode/variation: S8-2*	-40C to +85C	RoHS/Lead-Free: No Materials Analysis
ICL7611DESA-T			SOIC;8 pin;31 mm Dwg: 21-0041B (PDF) Use pkgcode/variation: S8-2*	-40C to +85C	RoHS/Lead-Free: No Materials Analysis
ICL7612	Free Sample	Buy	Package: TYPE PINS FOOTPRINT DRAWING CODE/VAR *	Temp	RoHS/Lead-Free? Materials Analysis
ICL7612DCPA+				0C to +70C	RoHS/Lead-Free: See data sheet
ICL7612AC/D					RoHS/Lead-Free: See data sheet
ICL7612BC/D					RoHS/Lead-Free: See data sheet
ICL7612DC/D					RoHS/Lead-Free: See data sheet
ICL7612BCTV			Gold Can -TO;8 pin;88 mm Dwg: 21-0022A (PDF) Use pkgcode/variation: G99-8*	0C to +70C	RoHS/Lead-Free: No Materials Analysis
ICL7612BMTV			Gold Can -TO;8 pin;88 mm Dwg: 21-0022A (PDF) Use pkgcode/variation: G99-8*	-55C to +125C	RoHS/Lead-Free: No Materials Analysis
ICL7612DMTV			Gold Can -TO;8 pin;88 mm Dwg: 21-0022A (PDF) Use pkgcode/variation: G99-8*	-55C to +125C	RoHS/Lead-Free: No Materials Analysis

ICL7612DCPA			PDIP;8 pin;82 mm Dwg: 21-0043D (PDF) Use pkgcode/variation: P8-1*	0C to +70C	RoHS/Lead-Free: No Materials Analysis
ICL7612BCPA			PDIP;8 pin;82 mm Dwg: 21-0043D (PDF) Use pkgcode/variation: P8-1*	0C to +70C	RoHS/Lead-Free: No Materials Analysis
ICL7612ACPA			PDIP;8 pin;82 mm Dwg: 21-0043D (PDF) Use pkgcode/variation: P8-1*	0C to +70C	RoHS/Lead-Free: No Materials Analysis
ICL7612DCSA+			SOIC;8 pin;31 mm Dwg: 21-0041B (PDF) Use pkgcode/variation: S8+2*	0C to +70C	RoHS/Lead-Free: Lead Free Materials Analysis
ICL7612ACSA+			SOIC;8 pin;31 mm Dwg: 21-0041B (PDF) Use pkgcode/variation: S8+2*	0C to +70C	RoHS/Lead-Free: Lead Free Materials Analysis
ICL7612BCSA+			SOIC;8 pin;31 mm Dwg: 21-0041B (PDF) Use pkgcode/variation: S8+2*	0C to +70C	RoHS/Lead-Free: Lead Free Materials Analysis
ICL7612DCSA+T			SOIC;8 pin;31 mm Dwg: 21-0041B (PDF) Use pkgcode/variation: S8+2*	0C to +70C	RoHS/Lead-Free: Lead Free Materials Analysis
ICL7612ACSA+T			SOIC;8 pin;31 mm Dwg: 21-0041B (PDF) Use pkgcode/variation: S8+2*	0C to +70C	RoHS/Lead-Free: Lead Free Materials Analysis
ICL7612BCSA+T			SOIC;8 pin;31 mm Dwg: 21-0041B (PDF) Use pkgcode/variation: S8+2*	0C to +70C	RoHS/Lead-Free: Lead Free Materials Analysis
ICL7612DCSA-T			SOIC;8 pin;31 mm Dwg: 21-0041B (PDF) Use pkgcode/variation: S8-2*	0C to +70C	RoHS/Lead-Free: No Materials Analysis
ICL7612DCSA			SOIC;8 pin;31 mm Dwg: 21-0041B (PDF) Use pkgcode/variation: S8-2*	0C to +70C	RoHS/Lead-Free: No Materials Analysis
ICL7612BCSA-T			SOIC;8 pin;31 mm Dwg: 21-0041B (PDF) Use pkgcode/variation: S8-2*	0C to +70C	RoHS/Lead-Free: No Materials Analysis
ICL7612BCSA			SOIC;8 pin;31 mm Dwg: 21-0041B (PDF) Use pkgcode/variation: S8-2*	0C to +70C	RoHS/Lead-Free: No Materials Analysis
ICL7612ACSA-T			SOIC;8 pin;31 mm Dwg: 21-0041B (PDF) Use pkgcode/variation: S8-2*	0C to +70C	RoHS/Lead-Free: No Materials Analysis
ICL7612ACSA			SOIC;8 pin;31 mm Dwg: 21-0041B (PDF) Use pkgcode/variation: S8-2*	0C to +70C	RoHS/Lead-Free: No Materials Analysis
ICL7612DESA-T			SOIC;8 pin;31 mm Dwg: 21-0041B (PDF) Use pkgcode/variation: S8-2*	-40C to +85C	RoHS/Lead-Free: No Materials Analysis
ICL7612BESA+			SOIC;8 pin;31 mm Dwg: 21-0041B (PDF) Use pkgcode/variation: S8+2*	-40C to +85C	RoHS/Lead-Free: Lead Free Materials Analysis
ICL7612BESA-T			SOIC;8 pin;31 mm Dwg: 21-0041B (PDF) Use pkgcode/variation: S8-2*	-40C to +85C	RoHS/Lead-Free: No Materials Analysis
ICL7612DESA+T			SOIC;8 pin;31 mm Dwg: 21-0041B (PDF) Use pkgcode/variation: S8+2*	-40C to +85C	RoHS/Lead-Free: Lead Free Materials Analysis
ICL7612DESA+			SOIC;8 pin;31 mm Dwg: 21-0041B (PDF) Use pkgcode/variation: S8+2*	-40C to +85C	RoHS/Lead-Free: Lead Free Materials Analysis
ICL7612BESA			SOIC;8 pin;31 mm Dwg: 21-0041B (PDF) Use pkgcode/variation: S8-2*	-40C to +85C	RoHS/Lead-Free: No Materials Analysis
ICL7612BESA+T			SOIC;8 pin;31 mm Dwg: 21-0041B (PDF) Use pkgcode/variation: S8+2*	-40C to +85C	RoHS/Lead-Free: Lead Free Materials Analysis
ICL7612DESA			SOIC;8 pin;31 mm Dwg: 21-0041B (PDF) Use pkgcode/variation: S8-2*	-40C to +85C	RoHS/Lead-Free: No Materials Analysis

ICL7614	Free Sample	Buy	Package: TYPE PINS FOOTPRINT DRAWING CODE/VAR *	Temp	RoHS/Lead-Free? Materials Analysis
ICL7614DC/D					RoHS/Lead-Free: See data sheet
ICL7614DCTV-2			Metal Can-TO;8 pin;88 mm Dwg: 21-0022A (PDF) Use pkgcode/variation: T99-8*	0C to +70C	RoHS/Lead-Free: No Materials Analysis
ICL7614DCPA-2			PDIP;8 pin;82 mm Dwg: 21-0043D (PDF) Use pkgcode/variation: P8-1*	0C to +70C	RoHS/Lead-Free: No Materials Analysis
ICL7614DCPA+			PDIP;8 pin;82 mm Dwg: 21-0043D (PDF) Use pkgcode/variation: P8+1*	0C to +70C	RoHS/Lead-Free: Lead Free Materials Analysis
ICL7614DCPA			PDIP;8 pin;82 mm Dwg: 21-0043D (PDF) Use pkgcode/variation: P8-1*	0C to +70C	RoHS/Lead-Free: No Materials Analysis
ICL7614ACPA			PDIP;8 pin;82 mm Dwg: 21-0043D (PDF) Use pkgcode/variation: P8-1*	0C to +70C	RoHS/Lead-Free: No Materials Analysis
ICL7614ACPA+			PDIP;8 pin;82 mm Dwg: 21-0043D (PDF) Use pkgcode/variation: P8+1*	0C to +70C	RoHS/Lead-Free: Lead Free Materials Analysis
ICL7614DCSA-T			SOIC;8 pin;31 mm Dwg: 21-0041B (PDF) Use pkgcode/variation: S8-2*	0C to +70C	RoHS/Lead-Free: No Materials Analysis
ICL7614ACSA-T			SOIC;8 pin;31 mm Dwg: 21-0041B (PDF) Use pkgcode/variation: S8-2*	0C to +70C	RoHS/Lead-Free: No Materials Analysis
ICL7614DCSA			SOIC;8 pin;31 mm Dwg: 21-0041B (PDF) Use pkgcode/variation: S8-2*	0C to +70C	RoHS/Lead-Free: No Materials Analysis
ICL7614ACSA			SOIC;8 pin;31 mm Dwg: 21-0041B (PDF) Use pkgcode/variation: S8-2*	0C to +70C	RoHS/Lead-Free: No Materials Analysis
ICL7616	Free Sample	Buy	Package: TYPE PINS FOOTPRINT DRAWING CODE/VAR *	Temp	RoHS/Lead-Free? Materials Analysis
ICL7616AMTV			Gold Can -TO;8 pin;88 mm Dwg: 21-0022A (PDF) Use pkgcode/variation: G99-8*	-55C to +125C	RoHS/Lead-Free: No Materials Analysis
ICL7616BMTV			Gold Can -TO;8 pin;88 mm Dwg: 21-0022A (PDF) Use pkgcode/variation: G99-8*	-55C to +125C	RoHS/Lead-Free: No Materials Analysis
ICL7616ACSA-T			SOIC;8 pin;31 mm Dwg: 21-0041B (PDF) Use pkgcode/variation: S8-2*	0C to +70C	RoHS/Lead-Free: No Materials Analysis
ICL7616ACSA			SOIC;8 pin;31 mm Dwg: 21-0041B (PDF) Use pkgcode/variation: S8-2*	0C to +70C	RoHS/Lead-Free: No Materials Analysis
ICL7621	Free Sample	Buy	Package: TYPE PINS FOOTPRINT DRAWING CODE/VAR *	Temp	RoHS/Lead-Free? Materials Analysis
ICL7621BC/D					RoHS/Lead-Free: See data sheet
ICL7621DC/D					RoHS/Lead-Free: See data sheet
ICL7621BCTV			Gold Can -TO;8 pin;88 mm Dwg: 21-0022A (PDF) Use pkgcode/variation: G99-8*	0C to +70C	RoHS/Lead-Free: No Materials Analysis
ICL7621DMTV			Gold Can -TO;8 pin;88 mm Dwg: 21-0022A (PDF) Use pkgcode/variation: G99-8*	-55C to +125C	RoHS/Lead-Free: No Materials Analysis
ICL7621BMTV			Gold Can -TO;8 pin;88 mm Dwg: 21-0022A (PDF) Use pkgcode/variation: G99-8*	-55C to +125C	RoHS/Lead-Free: No Materials Analysis

ICL7621ACPA			PDIP;8 pin;82 mm Dwg: 21-0043D (PDF) Use pkgcode/variation: P8-2*	0C to +70C	RoHS/Lead-Free: No Materials Analysis
ICL7621BCPA+			PDIP;8 pin;82 mm Dwg: 21-0043D (PDF) Use pkgcode/variation: P8+2*	0C to +70C	RoHS/Lead-Free: Lead Free Materials Analysis
ICL7621DCPA			PDIP;8 pin;82 mm Dwg: 21-0043D (PDF) Use pkgcode/variation: P8-2*	0C to +70C	RoHS/Lead-Free: No Materials Analysis
ICL7621DCPA+			PDIP;8 pin;82 mm Dwg: 21-0043D (PDF) Use pkgcode/variation: P8+2*	0C to +70C	RoHS/Lead-Free: Lead Free Materials Analysis
ICL7621BCPA			PDIP;8 pin;82 mm Dwg: 21-0043D (PDF) Use pkgcode/variation: P8-2*	0C to +70C	RoHS/Lead-Free: No Materials Analysis
ICL7621ACPA+			PDIP;8 pin;82 mm Dwg: 21-0043D (PDF) Use pkgcode/variation: P8+2*	0C to +70C	RoHS/Lead-Free: Lead Free Materials Analysis
ICL7621DCPA-2			PDIP;8 pin;82 mm Dwg: 21-0043D (PDF) Use pkgcode/variation: P8-2*	0C to +70C	RoHS/Lead-Free: No Materials Analysis
ICL7621ACSA+			SOIC;8 pin;31 mm Dwg: 21-0041B (PDF) Use pkgcode/variation: S8+4*	0C to +70C	RoHS/Lead-Free: Lead Free Materials Analysis
ICL7621ACSA+T			SOIC;8 pin;31 mm Dwg: 21-0041B (PDF) Use pkgcode/variation: S8+4*	0C to +70C	RoHS/Lead-Free: Lead Free Materials Analysis
ICL7621DCSA+			SOIC;8 pin;31 mm Dwg: 21-0041B (PDF) Use pkgcode/variation: S8+4*	0C to +70C	RoHS/Lead-Free: Lead Free Materials Analysis
ICL7621DCSA+T			SOIC;8 pin;31 mm Dwg: 21-0041B (PDF) Use pkgcode/variation: S8+4*	0C to +70C	RoHS/Lead-Free: Lead Free Materials Analysis
ICL7621BCSA+			SOIC;8 pin;31 mm Dwg: 21-0041B (PDF) Use pkgcode/variation: S8+4*	0C to +70C	RoHS/Lead-Free: Lead Free Materials Analysis
ICL7621DCSA			SOIC;8 pin;31 mm Dwg: 21-0041B (PDF) Use pkgcode/variation: S8-4*	0C to +70C	RoHS/Lead-Free: No Materials Analysis
ICL7621BCSA+T			SOIC;8 pin;31 mm Dwg: 21-0041B (PDF) Use pkgcode/variation: S8+4*	0C to +70C	RoHS/Lead-Free: Lead Free Materials Analysis
ICL7621ACSA			SOIC;8 pin;31 mm Dwg: 21-0041B (PDF) Use pkgcode/variation: S8-4*	0C to +70C	RoHS/Lead-Free: No Materials Analysis
ICL7621ACSA-T			SOIC;8 pin;31 mm Dwg: 21-0041B (PDF) Use pkgcode/variation: S8-4*	0C to +70C	RoHS/Lead-Free: No Materials Analysis
ICL7621BCSA-T			SOIC;8 pin;31 mm Dwg: 21-0041B (PDF) Use pkgcode/variation: S8-4*	0C to +70C	RoHS/Lead-Free: No Materials Analysis
ICL7621BCSA			SOIC;8 pin;31 mm Dwg: 21-0041B (PDF) Use pkgcode/variation: S8-4*	0C to +70C	RoHS/Lead-Free: No Materials Analysis
ICL7621DCSA-T			SOIC;8 pin;31 mm Dwg: 21-0041B (PDF) Use pkgcode/variation: S8-4*	0C to +70C	RoHS/Lead-Free: No Materials Analysis
ICL7621DESA+			SOIC;8 pin;31 mm Dwg: 21-0041B (PDF) Use pkgcode/variation: S8+4*	-40C to +85C	RoHS/Lead-Free: Lead Free Materials Analysis
ICL7621DESA+T			SOIC;8 pin;31 mm Dwg: 21-0041B (PDF) Use pkgcode/variation: S8+4*	-40C to +85C	RoHS/Lead-Free: Lead Free Materials Analysis
ICL7621DESA-T			SOIC;8 pin;31 mm Dwg: 21-0041B (PDF) Use pkgcode/variation: S8-4*	-40C to +85C	RoHS/Lead-Free: No Materials Analysis
ICL7621DESA			SOIC;8 pin;31 mm Dwg: 21-0041B (PDF) Use pkgcode/variation: S8-4*	-40C to +85C	RoHS/Lead-Free: No Materials Analysis

ICL7621BESA-T			SOIC;8 pin;31 mm Dwg: 21-0041B (PDF) Use pkgcode/variation: S8-4*	-40C to +85C	RoHS/Lead-Free: No Materials Analysis
ICL7621BESA			SOIC;8 pin;31 mm Dwg: 21-0041B (PDF) Use pkgcode/variation: S8-4*	-40C to +85C	RoHS/Lead-Free: No Materials Analysis
ICL7622	Free Sample	Buy	Package: TYPE PINS FOOTPRINT DRAWING CODE/VAR *	Temp	RoHS/Lead-Free? Materials Analysis
ICL7622BC/D					RoHS/Lead-Free: See data sheet
ICL7622DC/D					RoHS/Lead-Free: See data sheet
ICL7622ACPD			PDIP;14 pin;160 mm Dwg: 21-0043D (PDF) Use pkgcode/variation: P14-3*	0C to +70C	RoHS/Lead-Free: No Materials Analysis
ICL7622BCPD			PDIP;14 pin;160 mm Dwg: 21-0043D (PDF) Use pkgcode/variation: P14-3*	0C to +70C	RoHS/Lead-Free: No Materials Analysis
ICL7622DCPD			PDIP;14 pin;160 mm Dwg: 21-0043D (PDF) Use pkgcode/variation: P14-3*	0C to +70C	RoHS/Lead-Free: No Materials Analysis
ICL7622ACPD+			PDIP;14 pin;160 mm Dwg: 21-0043D (PDF) Use pkgcode/variation: P14+3*	0C to +70C	RoHS/Lead-Free: Lead Free Materials Analysis
ICL7622BCPD+			PDIP;14 pin;160 mm Dwg: 21-0043D (PDF) Use pkgcode/variation: P14+3*	0C to +70C	RoHS/Lead-Free: Lead Free Materials Analysis
ICL7622DCPD+			PDIP;14 pin;160 mm Dwg: 21-0043D (PDF) Use pkgcode/variation: P14+3*	0C to +70C	RoHS/Lead-Free: Lead Free Materials Analysis
ICL7631	Free Sample	Buy	Package: TYPE PINS FOOTPRINT DRAWING CODE/VAR *	Temp	RoHS/Lead-Free? Materials Analysis
ICL7631BMJE			Ceramic DIP;16 pin;173 mm Dwg: 21-0045A (PDF) Use pkgcode/variation: J16-3*	-55C to +125C	RoHS/Lead-Free: No Materials Analysis
ICL7631CMJE			Ceramic DIP;16 pin;173 mm Dwg: 21-0045A (PDF) Use pkgcode/variation: J16-3*	-55C to +125C	RoHS/Lead-Free: No Materials Analysis
ICL7631EC/D					RoHS/Lead-Free: See data sheet
ICL7631BC/D					RoHS/Lead-Free: See data sheet
ICL7631ECPE			PDIP;16 pin;160 mm Dwg: 21-0043D (PDF) Use pkgcode/variation: P16-1*	0C to +70C	RoHS/Lead-Free: No Materials Analysis
ICL7631BCPE			PDIP;16 pin;160 mm Dwg: 21-0043D (PDF) Use pkgcode/variation: P16-1*	0C to +70C	RoHS/Lead-Free: No Materials Analysis
ICL7631CCPE			PDIP;16 pin;160 mm Dwg: 21-0043D (PDF) Use pkgcode/variation: P16-1*	0C to +70C	RoHS/Lead-Free: No Materials Analysis
ICL7631ECSE-T			SOIC;16 pin;62 mm Dwg: 21-0041B (PDF) Use pkgcode/variation: S16-1*	0C to +70C	RoHS/Lead-Free: No Materials Analysis
ICL7631CCSE-T			SOIC;16 pin;62 mm Dwg: 21-0041B (PDF) Use pkgcode/variation: S16-1*	0C to +70C	RoHS/Lead-Free: No Materials Analysis
ICL7631ECSE			SOIC;16 pin;62 mm Dwg: 21-0041B (PDF) Use pkgcode/variation: S16-1*	0C to +70C	RoHS/Lead-Free: No Materials Analysis
ICL7631ECSE+T			SOIC;16 pin;62 mm Dwg: 21-0041B (PDF) Use pkgcode/variation: S16+1*	0C to +70C	RoHS/Lead-Free: Lead Free Materials Analysis

ICL7631ECSE+			SOIC;16 pin;62 mm Dwg: 21-0041B (PDF) Use pkgcode/variation: S16+1*	0C to +70C	RoHS/Lead-Free: Lead Free Materials Analysis
ICL7631BCSE			SOIC;16 pin;62 mm Dwg: 21-0041B (PDF) Use pkgcode/variation: S16-1*	0C to +70C	RoHS/Lead-Free: No Materials Analysis
ICL7631CCSE			SOIC;16 pin;62 mm Dwg: 21-0041B (PDF) Use pkgcode/variation: S16-1*	0C to +70C	RoHS/Lead-Free: No Materials Analysis
ICL7631BCSE-T			SOIC;16 pin;62 mm Dwg: 21-0041B (PDF) Use pkgcode/variation: S16-1*	0C to +70C	RoHS/Lead-Free: No Materials Analysis
ICL7632	Free Sample	Buy	Package: TYPE PINS FOOTPRINT DRAWING CODE/VAR *	Temp	RoHS/Lead-Free? Materials Analysis
ICL7632BCPE			PDIP;16 pin;160 mm Dwg: 21-0043D (PDF) Use pkgcode/variation: P16-1*	0C to +70C	RoHS/Lead-Free: No Materials Analysis
ICL7632ECPE			PDIP;16 pin;160 mm Dwg: 21-0043D (PDF) Use pkgcode/variation: P16-1*	0C to +70C	RoHS/Lead-Free: No Materials Analysis
ICL7632BCSE			SOIC;16 pin;62 mm Dwg: 21-0041B (PDF) Use pkgcode/variation: S16-1*	0C to +70C	RoHS/Lead-Free: No Materials Analysis
ICL7632BCSE-T			SOIC;16 pin;62 mm Dwg: 21-0041B (PDF) Use pkgcode/variation: S16-1*	0C to +70C	RoHS/Lead-Free: No Materials Analysis
ICL7632ECSE-T			SOIC;16 pin;62 mm Dwg: 21-0041B (PDF) Use pkgcode/variation: S16-1*	0C to +70C	RoHS/Lead-Free: No Materials Analysis
ICL7632ECSE			SOIC;16 pin;62 mm Dwg: 21-0041B (PDF) Use pkgcode/variation: S16-1*	0C to +70C	RoHS/Lead-Free: No Materials Analysis
ICL7641	Free Sample	Buy	Package: TYPE PINS FOOTPRINT DRAWING CODE/VAR *	Temp	RoHS/Lead-Free? Materials Analysis
ICL7641ECJD			Ceramic DIP;14 pin;162 mm Dwg: 21-0045A (PDF) Use pkgcode/variation: J14-3*	0C to +70C	RoHS/Lead-Free: No Materials Analysis
ICL7641BCJD			Ceramic DIP;14 pin;162 mm Dwg: 21-0045A (PDF) Use pkgcode/variation: J14-3*	0C to +70C	RoHS/Lead-Free: No Materials Analysis
ICL7641BMJD			Ceramic DIP;14 pin;162 mm Dwg: 21-0045A (PDF) Use pkgcode/variation: J14-3*	-55C to +125C	RoHS/Lead-Free: No Materials Analysis
ICL7641CMJD			Ceramic DIP;14 pin;162 mm Dwg: 21-0045A (PDF) Use pkgcode/variation: J14-3*	-55C to +125C	RoHS/Lead-Free: No Materials Analysis
ICL7641BMJD/HR			Ceramic DIP;14 pin;162 mm Dwg: 21-0045A (PDF) Use pkgcode/variation: J14-3*	-55C to +125C	RoHS/Lead-Free: No Materials Analysis
ICL7641EC/D					RoHS/Lead-Free: See data sheet
ICL7641CCPD			PDIP;14 pin;160 mm Dwg: 21-0043D (PDF) Use pkgcode/variation: P14-4*	0C to +70C	RoHS/Lead-Free: No Materials Analysis
ICL7641CCPD+			PDIP;14 pin;160 mm Dwg: 21-0043D (PDF) Use pkgcode/variation: P14+4*	0C to +70C	RoHS/Lead-Free: Lead Free Materials Analysis
ICL7641ECPD+			PDIP;14 pin;160 mm Dwg: 21-0043D (PDF) Use pkgcode/variation: P14+4*	0C to +70C	RoHS/Lead-Free: Lead Free Materials Analysis
ICL7641ECPD			PDIP;14 pin;160 mm Dwg: 21-0043D (PDF) Use pkgcode/variation: P14-4*	0C to +70C	RoHS/Lead-Free: No Materials Analysis
ICL7641BCPD+			PDIP;14 pin;160 mm Dwg: 21-0043D (PDF) Use pkgcode/variation: P14+4*	0C to +70C	RoHS/Lead-Free: Lead Free Materials Analysis

ICL7641BCPD			PDIP;14 pin;160 mm Dwg: 21-0043D (PDF) Use pkgcode/variation: P14-4*	0C to +70C	RoHS/Lead-Free: No Materials Analysis
ICL7641BCWE-T			SOIC;16 pin;112 mm Dwg: 21-0042B (PDF) Use pkgcode/variation: W16-2*	0C to +70C	RoHS/Lead-Free: No Materials Analysis
ICL7641BCWE			SOIC;16 pin;112 mm Dwg: 21-0042B (PDF) Use pkgcode/variation: W16-2*	0C to +70C	RoHS/Lead-Free: No Materials Analysis
ICL7641ECWE+			SOIC;16 pin;112 mm Dwg: 21-0042B (PDF) Use pkgcode/variation: W16+2*	0C to +70C	RoHS/Lead-Free: Lead Free Materials Analysis
ICL7641CCWE+T			SOIC;16 pin;112 mm Dwg: 21-0042B (PDF) Use pkgcode/variation: W16+2*	0C to +70C	RoHS/Lead-Free: Lead Free Materials Analysis
ICL7641CCWE+			SOIC;16 pin;112 mm Dwg: 21-0042B (PDF) Use pkgcode/variation: W16+2*	0C to +70C	RoHS/Lead-Free: Lead Free Materials Analysis
ICL7641BCWE+T			SOIC;16 pin;112 mm Dwg: 21-0042B (PDF) Use pkgcode/variation: W16+2*	0C to +70C	RoHS/Lead-Free: Lead Free Materials Analysis
ICL7641BCWE+			SOIC;16 pin;112 mm Dwg: 21-0042B (PDF) Use pkgcode/variation: W16+2*	0C to +70C	RoHS/Lead-Free: Lead Free Materials Analysis
ICL7641ECWE+T			SOIC;16 pin;112 mm Dwg: 21-0042B (PDF) Use pkgcode/variation: W16+2*	0C to +70C	RoHS/Lead-Free: Lead Free Materials Analysis
ICL7641CCWE			SOIC;16 pin;112 mm Dwg: 21-0042B (PDF) Use pkgcode/variation: W16-2*	0C to +70C	RoHS/Lead-Free: No Materials Analysis
ICL7641CCWE-T			SOIC;16 pin;112 mm Dwg: 21-0042B (PDF) Use pkgcode/variation: W16-2*	0C to +70C	RoHS/Lead-Free: No Materials Analysis
ICL7641ECWE			SOIC;16 pin;112 mm Dwg: 21-0042B (PDF) Use pkgcode/variation: W16-2*	0C to +70C	RoHS/Lead-Free: No Materials Analysis
ICL7641ECWE-T			SOIC;16 pin;112 mm Dwg: 21-0042B (PDF) Use pkgcode/variation: W16-2*	0C to +70C	RoHS/Lead-Free: No Materials Analysis
ICL7642	Free Sample	Buy	Package: TYPE PINS FOOTPRINT DRAWING CODE/VAR *	Temp	RoHS/Lead-Free? Materials Analysis
ICL7642ECJD			Ceramic DIP;14 pin;162 mm Dwg: 21-0045A (PDF) Use pkgcode/variation: J14-3*	0C to +70C	RoHS/Lead-Free: No Materials Analysis
ICL7642CMJD			Ceramic DIP;14 pin;162 mm Dwg: 21-0045A (PDF) Use pkgcode/variation: J14-3*	-55C to +125C	RoHS/Lead-Free: No Materials Analysis
ICL7642BMJD/HR			Ceramic DIP;14 pin;162 mm Dwg: 21-0045A (PDF) Use pkgcode/variation: J14-3*	-55C to +125C	RoHS/Lead-Free: No Materials Analysis
ICL7642BMJD			Ceramic DIP;14 pin;162 mm Dwg: 21-0045A (PDF) Use pkgcode/variation: J14-3*	-55C to +125C	RoHS/Lead-Free: No Materials Analysis
ICL7642EC/D					RoHS/Lead-Free: See data sheet
ICL7642CC/D					RoHS/Lead-Free: See data sheet
ICL7642BCPD+			PDIP;14 pin;160 mm Dwg: 21-0043D (PDF) Use pkgcode/variation: P14+4*	0C to +70C	RoHS/Lead-Free: Lead Free Materials Analysis
ICL7642ECPD			PDIP;14 pin;160 mm Dwg: 21-0043D (PDF) Use pkgcode/variation: P14-4*	0C to +70C	RoHS/Lead-Free: No Materials Analysis
ICL7642CCPD+			PDIP;14 pin;160 mm Dwg: 21-0043D (PDF) Use pkgcode/variation: P14+4*	0C to +70C	RoHS/Lead-Free: Lead Free Materials Analysis

ICL7642ECPD+			PDIP;14 pin;160 mm Dwg: 21-0043D (PDF) Use pkgcode/variation: P14+4*	0C to +70C	RoHS/Lead-Free: Lead Free Materials Analysis
ICL7642CCPD			PDIP;14 pin;160 mm Dwg: 21-0043D (PDF) Use pkgcode/variation: P14-4*	0C to +70C	RoHS/Lead-Free: No Materials Analysis
ICL7642BCPD			PDIP;14 pin;160 mm Dwg: 21-0043D (PDF) Use pkgcode/variation: P14-4*	0C to +70C	RoHS/Lead-Free: No Materials Analysis
ICL7642BCWE+T			SOIC;16 pin;112 mm Dwg: 21-0042B (PDF) Use pkgcode/variation: W16+2*	0C to +70C	RoHS/Lead-Free: Lead Free Materials Analysis
ICL7642BCWE+			SOIC;16 pin;112 mm Dwg: 21-0042B (PDF) Use pkgcode/variation: W16+2*	0C to +70C	RoHS/Lead-Free: Lead Free Materials Analysis
ICL7642ECWE-T			SOIC;16 pin;112 mm Dwg: 21-0042B (PDF) Use pkgcode/variation: W16-2*	0C to +70C	RoHS/Lead-Free: No Materials Analysis
ICL7642ECWE			SOIC;16 pin;112 mm Dwg: 21-0042B (PDF) Use pkgcode/variation: W16-2*	0C to +70C	RoHS/Lead-Free: No Materials Analysis
ICL7642CCWE			SOIC;16 pin;112 mm Dwg: 21-0042B (PDF) Use pkgcode/variation: W16-2*	0C to +70C	RoHS/Lead-Free: No Materials Analysis
ICL7642BCWE			SOIC;16 pin;112 mm Dwg: 21-0042B (PDF) Use pkgcode/variation: W16-2*	0C to +70C	RoHS/Lead-Free: No Materials Analysis
ICL7642BCWE-T			SOIC;16 pin;112 mm Dwg: 21-0042B (PDF) Use pkgcode/variation: W16-2*	0C to +70C	RoHS/Lead-Free: No Materials Analysis
ICL7642BEWE			SOIC;16 pin;112 mm Dwg: 21-0042B (PDF) Use pkgcode/variation: W16-2*	-40C to +85C	RoHS/Lead-Free: No Materials Analysis
ICL7642BEWE-T			SOIC;16 pin;112 mm Dwg: 21-0042B (PDF) Use pkgcode/variation: W16-2*	-40C to +85C	RoHS/Lead-Free: No Materials Analysis

Didn't Find What You Need?

- [Next Day Product Selection Assistance from Applications Engineers](#)
- [Parametric Search](#)
- [Applications Help](#)

QuickView

[Description](#)
[Key Features](#)
[Applications/Uses](#)
[Key Specifications](#)
[Diagram](#)

Technical Documents

[Data Sheet](#)
[Application Notes](#)
[Design Guides](#)
[Engineering Journals](#)
[Reliability Reports](#)
[Software/Models](#)
[Evaluation Kits](#)

Ordering Info

[Price and Availability](#)
[Samples](#)
[Buy Online](#)
[Package Information](#)
[Lead-Free Information](#)

More Information

[Related Products](#)
[Notes and Comments](#)
[Evaluation Kits](#)

Document Ref.: 19-0942; Rev 1; 2006-07-25
This page last modified: 2007-08-14

[CONTACT US: SEND US AN EMAIL](#)