

Customer Information Sheet

DRAWING No.: M80-582XXXX

SHEET 2 OF 2

IF IN DOUBT - ASK

©

NOT TO SCALE

THIRD ANGLE PROJECTION

ALL DIMENSIONS IN mm

SPECIFICATIONS:

MATERIAL:
 MOULDING = GLASS-FILLED PPS,
 UL94V-0, BLACK
 CONTACT = COPPER ALLOY
 JACKSCREW = STAINLESS STEEL

FINISH:
 05 = 0.25-0.3µ GOLD
 46 = 3.5-5.0µ 100% TIN SHELL

ELECTRICAL:
 CURRENT RATING AT 25°C = 3.0A MAX
 CURRENT RATING AT 85°C = 2.2A MAX
 WORKING VOLTAGE = 120V AC/DC
 VOLTAGE PROOF = 360V AC/DC
 CONTACT RESISTANCE = 25 mΩ MAX
 INSULATION RESISTANCE = 100 MΩ MIN

MECHANICAL:
 DURABILITY = 500 OPERATIONS

ENVIRONMENTAL:
 TEMPERATURE RANGE = -55°C TO +125°C

PACKING:
 LOOSE

FOR COMPLETE SPECIFICATION,
 SEE COMPONENT SPECIFICATION
 C005XX (LATEST ISSUE)

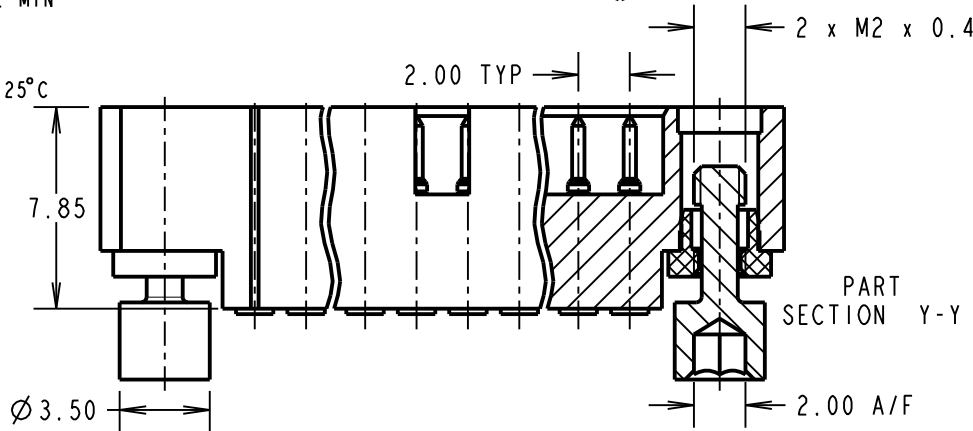
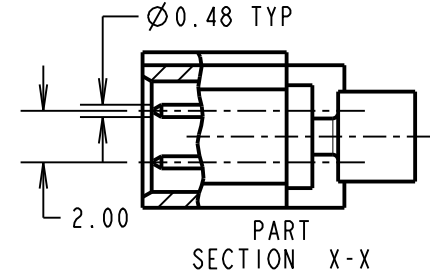
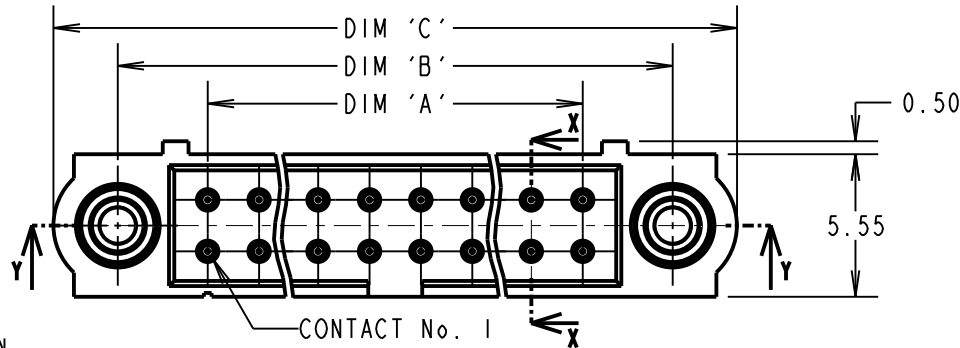

NOTES:

- CONNECTORS ARE SUPPLIED WITH CONTACTS LOOSE.
- FOR EXTRA CONTACTS, USE PART NUMBER M80-1940005 FOR M80-582XX05 AND M80-1940006 FOR M80-582XX46.
- RECOMMENDED WIRE TYPE = BS 3G 210 TYPE A, PTFE INSULATED 24-28 AWG. MAX INSULATION DIAMETER = Ø1.10mm, STRIP WIRE BY 2.00mm.
- RECOMMENDED HAND CRIMP TOOL = M22520/2-01 WITH POSITIONER T5747. REFER TO TOOLING INSTRUCTION SHEET IS-01 FOR COMPLETE CRIMPING INSTRUCTIONS.
- CONTACT INSERTION AND EXTRACTION TOOL = Z80-280. REFER TO TOOLING INSTRUCTION SHEET IS-25 FOR ASSEMBLY INSTRUCTIONS.

DIMENSION	CALCULATION
DIM 'A'	TOTAL No. OF CONTACTS - 2
DIM 'B'	TOTAL No. OF CONTACTS + 5
DIM 'C'	TOTAL No. OF CONTACTS + 10
EXAMPLE: CONNECTOR WITH 20 GOLD CONTACTS, M80-5822005	
DIM 'A' = 18.00mm, DIM 'B' = 25.00mm, DIM 'C' = 30.00mm	

ORDER CODE:

M80-582XXXX

TOTAL No. OF CONTACTS _____
 04 TO 50
 (EVEN NUMBERS ONLY)

FINISH CODE _____
 05 - GOLD
 46 - 100% TIN

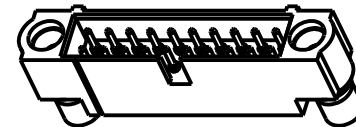

SB	I	09.08.11	11376
NAME	ISS.	DATE	C/NOTE
APPROVED:		S.BENNETT	
CHECKED:		S.FLOWER	
DRAWN:		R.ADDE	
CUSTOMER REF.:			
ASSEMBLY DRG:			

HARWIN

HARWIN USA TEL: 603 893 5376 FAX: 603 893 5396 mis@harwin.com	HARWIN Europe (UK) TEL: 023 9231 4545 FAX: 023 9231 4590 mis@harwin.co.uk	HARWIN Asia TEL: +65 6 779 4909 FAX: +65 6 779 3868 mis@harwin.com.sg
--	--	--

THIS DRAWING AND ANY INFORMATION OR DESCRIPTIVE MATTER SET OUT HEREON ARE CONFIDENTIAL AND COPYRIGHT PROPERTY OF THE HARWIN GROUP AND MUST NOT BE DISCLOSED, LOANED, COPIED OR USED FOR MANUFACTURING, TENDERING OR FOR ANY OTHER PURPOSE WITHOUT THEIR WRITTEN PERMISSION.

TOLERANCES
 X. = ±1mm
 X.X = ±0.25mm
 X.XX = ±0.10mm
 X.XXX = ±0.01mm

ANGLES = ±5°
 UNLESS STATED

MATERIAL:
 SEE ABOVE

FINISH: SEE ABOVE

S/AREA: mm²

TITLE: DATAMATE J-TEK
 MALE DIL LARGE BORE CRIMP
 WITH 'REVERSE FIX' JACKSCREW

DRAWING NUMBER:
M80-582XXXX

SHT 2 OF 2