



# Forward-Mode Transformers

For 30 Watt  
Telecommunications



- Designed to meet 30 W PoE IEEE 802.3at-2009 standard.
- Operates at 250 kHz with 36 – 72 Volts input.
- 1500 Vrms isolation, primary and bias to the secondary
- Bias winding output: 12 V; sync winding output: 5 V

**Core material** Ferrite

**Terminations** RoHS tin-silver over tin over nickel over phos bronze. Other terminations available at additional cost.

**Weight** 10.1 – 10.7 g

**Ambient temperature** –40°C to +125°C

**Storage temperature** Component: –40°C to +125°C.  
Packaging: –40°C to +80°C

**Resistance to soldering heat** Max three 40 second reflows at +260°C, parts cooled to room temperature between cycles

**Moisture Sensitivity Level (MSL)** 1 (unlimited floor life at <30°C / 85% relative humidity)

**Failures in Time (FIT) / Mean Time Between Failures (MTBF)**

38 per billion hours / 26,315,789 hours, calculated per Telcordia SR-332

**Packaging** 175 per 13" reel Plastic tape: 44 mm wide, 0.4 mm thick, 32 mm pocket spacing, 12.0 mm pocket depth

**PCB washing** Only pure water or alcohol recommended

Part number <sup>1</sup>	Inductance <sup>2</sup> min (µH)	DCR max (mOhms) <sup>3</sup>				Leakage inductance <sup>4</sup> max (µH)	Turns ratio <sup>5</sup>			Output	Recommended output inductor <sup>6</sup>
		pri	sec	bias	sync		pri:sec	pri:bias	pri:sync		
FCT1-33D3SL_	72.9	27.5	5.0	250	160	0.425	1:0.33	1:1	1:0.56	3.3 V, 9 A	SER2013-472
FCT1-50D3SL_	72.9	27.5	10.0	250	160	0.420	1:0.44	1:1	1:0.56	5 V, 6 A	SER1360-103
FCT1-120D3SL_	72.9	27.5	28.5	250	160	0.175	1:1	1:1	1:0.56	12 V, 2.5 A	MSS1278-563
FCT1-195D3SL_	72.9	27.5	32.0	235	120	0.235	1:1.44	1:0.88	1:0.44	19.5 V, 1.55 A	MSS1278-154
FCT1-240D3SL_	72.9	27.5	72.5	235	120	0.235	1:1.78	1:0.88	1:0.44	24 V, 1.25 A	MSS1278-224

1. When ordering, please specify **termination** and **packaging** codes:

FCT1-240D3SL D

**Termination:** L = RoHS tin-silver over tin over nickel over phos bronze.  
Special order: T = RoHS tin-silver-copper (95.5/4/0.5) or S = non-RoHS tin-lead (63/37).

**Packaging:** D = 13" machine-ready reel. EIA-481 embossed plastic tape (175 parts per full reel).

B = Less than full reel. In tape, but not machine ready. To have a leader and trailer added (\$25 charge), use code letter D instead.

- Inductance is measured at 250 kHz, 0.2 Vrms, 0 Adc.
- DCR for the primary and secondary is with the windings connected in parallel.
- Leakage inductance is for the primary windings with the secondary windings shorted.
- Turns ratio is with the primary windings and the secondary windings connected in parallel.
- These inductors are recommended for 30% ripple current. Ripple less than 30% may require the use of physically larger inductors. Allowing higher ripple current to make use of smaller inductors may create a risk of discontinuous output current.
- Operating temperature range –40°C to +125°C.
- Electrical specifications at 25°C.

Refer to Doc 362 "Soldering Surface Mount Components" before soldering.

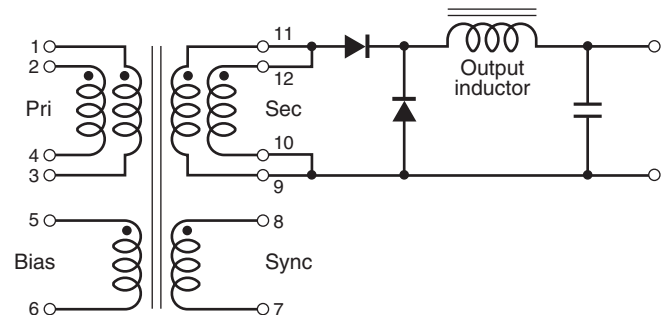

The primary windings and the secondary windings are to be connected in parallel on the PCB board.

**Coilcraft**<sup>®</sup>

Specifications subject to change without notice.  
Please check our website for latest information.

Document 574-1 Revised 10/28/08

1102 Silver Lake Road Cary, Illinois 60013 Phone 847/639-6400 Fax 847/639-1469

E-mail [info@coilcraft.com](mailto:info@coilcraft.com) Web <http://www.coilcraft.com>



# Forward-Mode Transformers – 30 Watts

Dot indicates pin 1

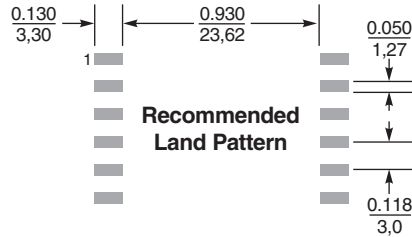
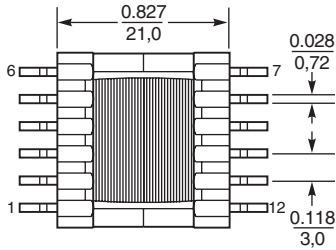
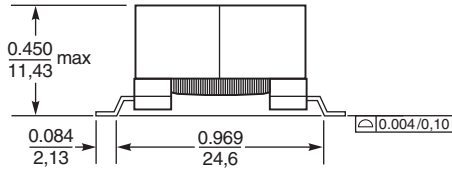
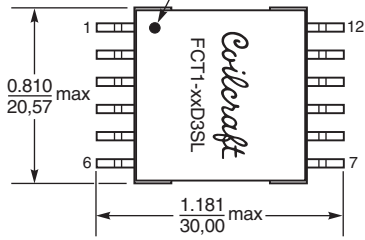

Dimensions are in  $\frac{\text{inches}}{\text{mm}}$



Specifications subject to change without notice.  
Please check our website for latest information.

Document 574-2 Revised 10/28/08

1102 Silver Lake Road Cary, Illinois 60013 Phone 847/639-6400 Fax 847/639-1469

E-mail [info@coilcraft.com](mailto:info@coilcraft.com) Web <http://www.coilcraft.com>