

CTSPT-L

From 1.1 μH to 2000 μH

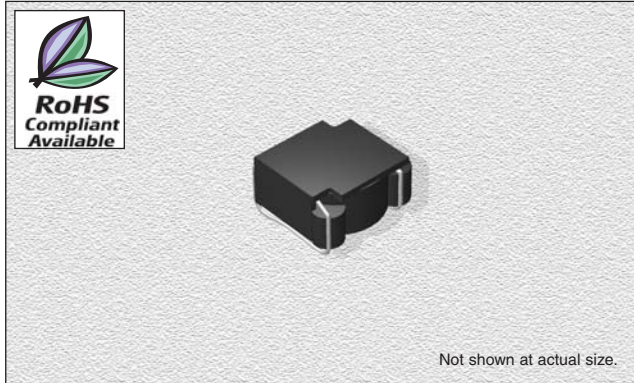

CHARACTERISTICS

Description: Surface mount standard toroidal inductor.

Applications: For use in DC/DC converters, notebooks, computers, and mobile appliances. Boost and buck switcher. Designed for SMD pick and place mounting and reflow soldering.

Operating Temperature: -40°C to +130°C

Testing: Tested on an HP4284A at 100 kHz 0.1 Vrms

Electrical Specification: @ 25°C

Temperature Rise: 55°C typical at I_{dc} and 25°C ambient temperature.

Miscellaneous: RoHS Compliant available. Meets UL94V-0. Operating frequency up to 1 MHz.

Additional Information: Additional electrical & physical information available upon request

Samples available. See website for ordering information.

SPECIFICATIONS

CTSPT--LE Please specify "F" for RoHS Compliant

Part Number	Inductance (no DC) $\pm 20\%$. (μH)	Current DC (Amp.)	Inductance (w/ DC) Typ. (μH)	DCR $\pm 20\%$ (Ω)	Size Code
CTSPT20L_-702M	7.0	1.40	6.20	0.070	M
CTSPT20L_-233M	23	1.00	17.6	0.125	M
CTSPT30L_-353M	35	1.40	29.7	0.166	N
CTSPT38L_-733M	73	1.30	58.1	0.290	O
CTSPT30L_-174M	170	0.94	114	0.380	N
CTSPT38L_-294M	290	0.90	192	0.560	O
CTSPT38L_-674M	670	0.72	383	0.862	O
CTSPT44L_-115M	1100	0.74	645	1.250	P
CTSPT50L_-205M	2000	0.71	1070	1.700	Q
CTSPT20L_-112M	1.1	3.40	1.01	0.011	M
CTSPT30L_-123M	12	2.80	9.4	0.043	N
CTSPT38L_-223M	22	2.70	16.2	0.063	O
CTSPT44L_-413M	41	2.70	29.1	0.085	P
CTSPT50L_-733M	73	2.60	50.0	0.133	Q
CTSPT30L_-522M	5.2	4.80	3.8	0.017	N
CTSPT38L_-752M	7.5	5.40	5.1	0.018	O
CTSPT44L_-143M	14	5.50	9.0	0.022	P
CTSPT50L_-263M	26	5.10	16.1	0.032	Q
CTSPT38L_-382M	3.8	8.00	2.5	0.008	O
CTSPT44L_-792M	7.9	7.80	4.9	0.012	P
CTSPT50L_-163M	16	7.20	9.3	0.019	Q

PHYSICAL DIMENSIONS (inch)

Size Code	A Max.	B Max.	C Max.	D	E	F
M	0.340	0.340	0.270	0.260	0.300	0.270
N	0.435	0.440	0.360	0.350	0.400	0.360
O	0.560	0.565	0.360	0.450	0.520	0.460
P	0.590	0.615	0.390	0.500	0.550	0.510
Q	0.670	0.700	0.390	0.580	0.620	0.590

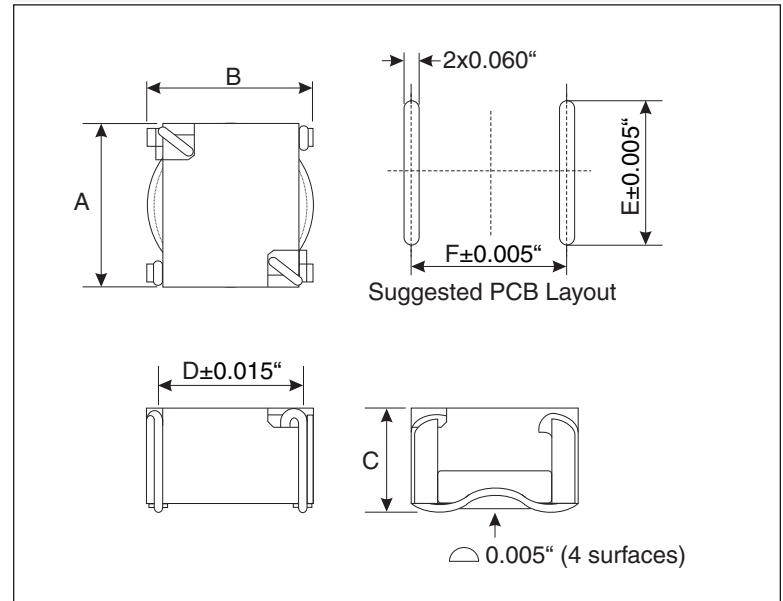

05.14.10