

■ FEATURES

- Lead-free Type. RoHS Compliant.
- Ultra-Low ESR
- Same Dimension as E/SV series

■ DIMENSIONS [mm]

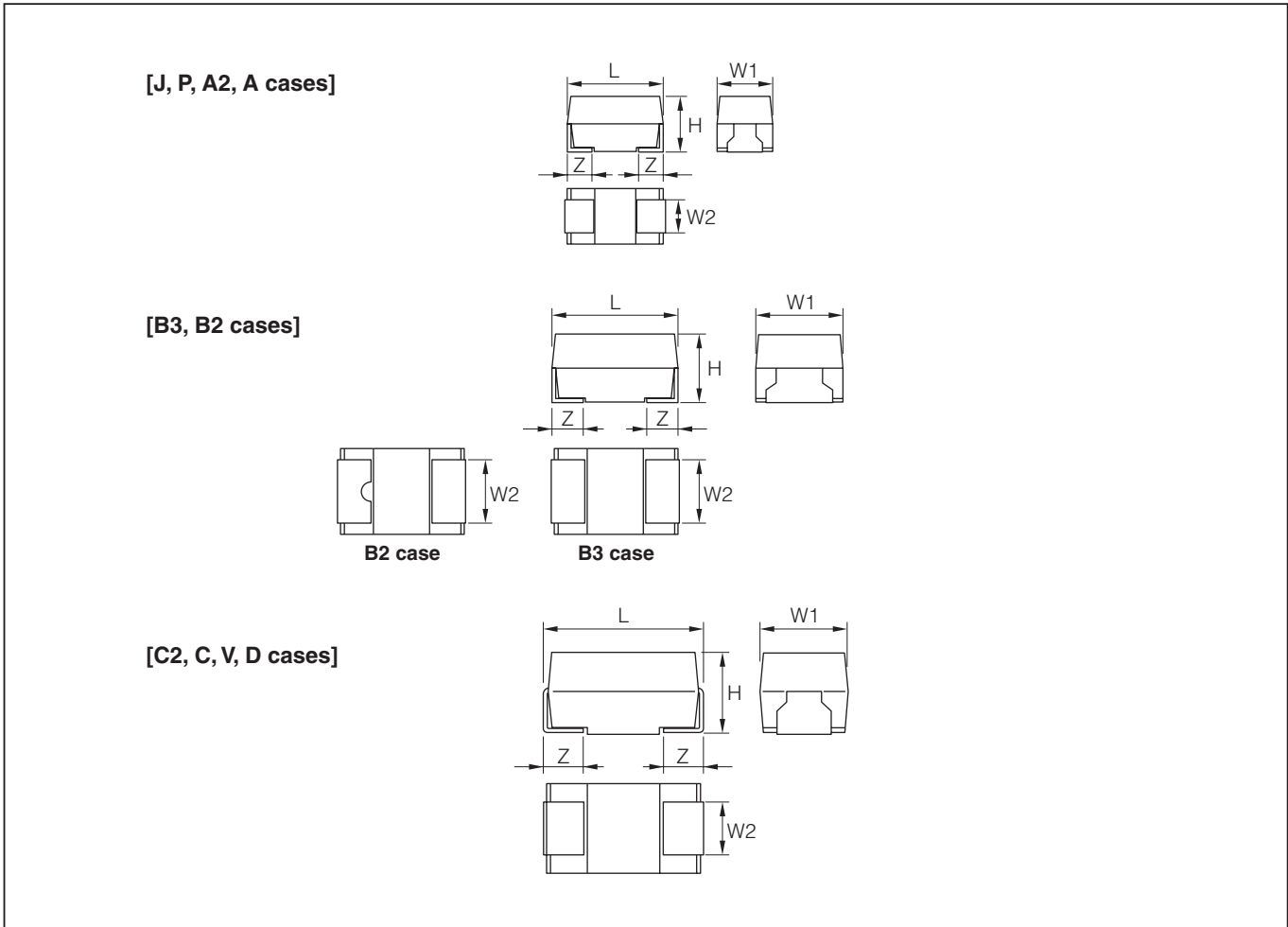

(Unit: mm)

Case code	EIA code	L	W ¹	W ²	H	Z
J	—	1.6±0.1	0.8±0.1	0.6±0.1	0.8±0.1	0.3±0.15
P	2012	2.0±0.2	1.25±0.2	0.9±0.1	1.1±0.1	0.5±0.1
A2 (U)	3216L	3.2±0.2	1.6±0.2	1.2±0.1	1.1±0.1	0.8±0.2
A	3216	3.2±0.2	1.6±0.2	1.2±0.1	1.6±0.2	0.8±0.2
B3 (W)	3528L	3.5±0.2	2.8±0.2	2.2±0.1	1.1±0.1	0.8±0.2
B2 (S)	3528	3.5±0.2	2.8±0.2	2.2±0.1	1.9±0.2	0.8±0.2
C2	—	6.0±0.2	3.2±0.2	2.2±0.1	1.4±0.1	1.3±0.2
C	6032	6.0±0.2	3.2±0.2	2.2±0.1	2.5±0.2	1.3±0.2
V	7343L	7.3±0.2	4.3±0.2	2.4±0.1	1.9±0.1	1.3±0.2
D	7343	7.3±0.2	4.3±0.2	2.4±0.1	2.8±0.2	1.3±0.2

■ STANDARD C-V VALUE REFERENCE BY CASE CODE

μF \ UR		2.5 V	4V	6.3V	10V	16V	20V	25V
		0E	0G	0J	1A	1C	1D	1E
1.0	105							
2.2	225			J	J			
3.3	335			J, P	A	A		
4.7	475			J, P	A2, A	B2		
6.8	685			P, A	A2, A, B2	B2		
10	106		J, P, A	P, A2, A	A2, A, B2	B2		
15	156			A2, A, B2	A, B2, C			
22	226	P	P, A2, B2	A2, A, B3, B2	A, B3, B2, C			
33	336	A2	A2, A	A, B3, B2	A, B3, B2, C2, C	V		
47	476	A2	A, B3	A, B3, B2, C2, C	B3, B2, C2, C, V, D	V, D		
68	686		A, C2, C	B3, B2, C2, C	C2, C, V, D			
100	107	B3	B3, B2, C2	B2, C2, C	C2, C, V, D			
150	157		B2, C	B2, C2, C, V, D	C, V, D			
220	227	B2	B2, C, V, D	V, D	D			
330	337	B2, C, V	C, V, D	V, D				
470	477	V	D					
680	687	D	D					
1000	108	D						

■ PART NUMBER SYSTEM

[Bulk]

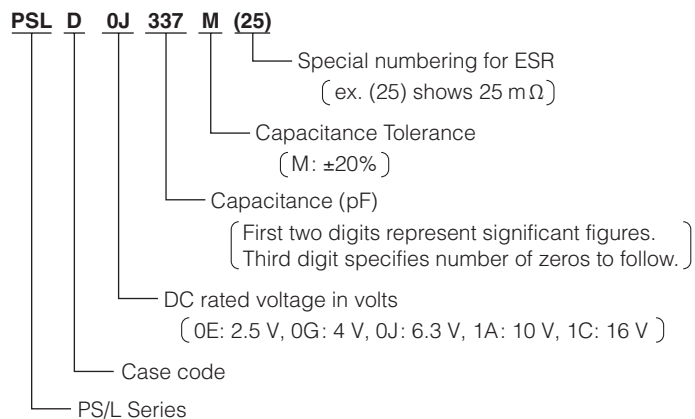

[Tape and Reel]

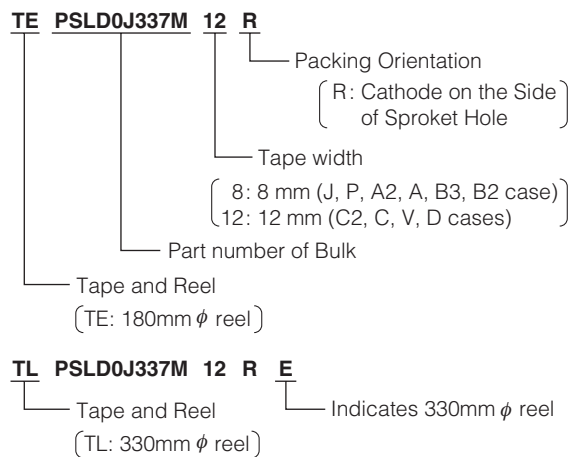

[J case] (ex. 4.7 μ F / 6.3 V)

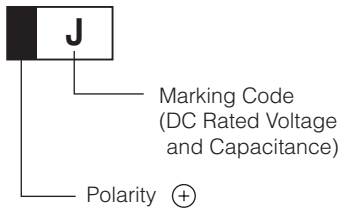

[J case Marking Code]

μ F \ U ^R	4V	6.3V	10V
2.2		┌	<
3.3		┘	
4.7		J	
6.8			
10	Ω		

[P case] (ex. 10 μ F / 4 V)

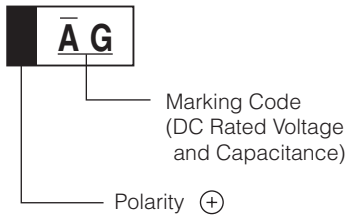

[P case Marking Code]

μ F \ U ^R	2.5V	4V	6.3V	10V	16V
1.0					
2.2					
3.3			NJ		
4.7			SJ		
6.8			WJ		
10		AG	AJ		
15					
22	Je	JG			

[A2, A cases] (ex. 10 μ F / 6.3 V)

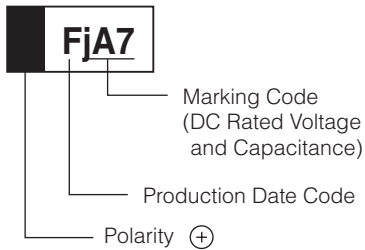

[A2, A, B3, B2, C2, C, V, D cases Marking Code]

μ F	U ^R	2.5V	4V	6.3V	10V	16V	20V	25V
		e	g	j	A	C	D	E
3.3	N6				AN6	CN6		
4.7	S6				AS6	CS6		
6.8	W6			jW6	AW6	CW6		
10	A7		gA7	JA7	AA7	CA7		
15	E7			JE7	AE7			
22	J7		gJ7	JJ7	AJ7			
33	N7	eN7	gN7	jN7	AN7	CN7		
47	S7	eS7	gS7	JS7	AS7	CS7		
68	W7		gW7	jW7	AW7			
100	AB	eA8	gA8	JA8	AA8			
150	E8		gE8	JE8	AE8			
220	J8	eJ8	gJ8	JJ8	AJ8			
330	N8	eN8	gN8	jN8				
470	S8	eS8	gS8					
680	W8	eW8	gW8					
1000	A9	eA9						

[B3, B2 cases] (ex. 15 μ F / 6.3 V)

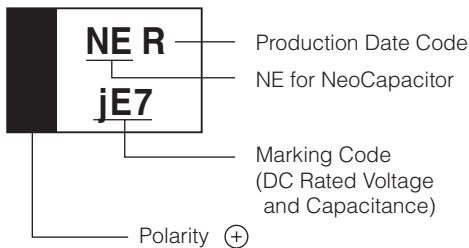

[C2, C, D cases] (ex. 150 μ F / 6.3 V)

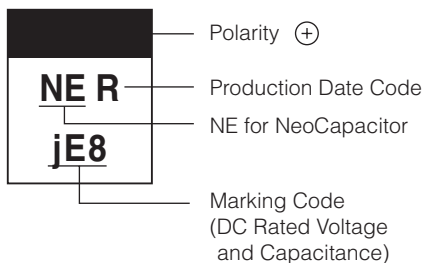

[A2, A, B3, B2, C2, C, V, D cases production date code]

Y \ M	Jan.	Feb.	Mar.	Apr.	May.	Jun.	Jul.	Aug.	Sep.	Oct.	Nov.	Dec.
2005	A	B	C	D	E	F	G	H	J	K	L	M
2006	N	P	Q	R	S	T	U	V	W	X	Y	Z
2007	a	b	c	d	e	f	g	h	j	k	l	m
2008	n	p	q	r	s	t	u	v	w	x	y	z

Note : Production date code will resume beginning in 2009

■ PERFORMANCE CHARACTERISTICS

Test Conditions : Conform to IEC 60384-1

ITEM		PERFORMANCE				TEST CONDITION	
Operating temperature		-55°C to +105°C				Derate voltage at 85°C at more	
Rated voltage (V.dc)		2.5V	4V	6.3V	10V	16V	at 85°C
Derated voltage (V.dc)		2V	3.3V	5V	8V	12.8V	at 105°C
Surge voltage (V.dc)		3.3V	5.2V	8V	13V	20V	at 85°C
Capacitance		2.2 μ F to 1000 μ F				at 120 Hz	
Capacitance tolerance		$\pm 20\%$					
DC Leakage Current (L.C)		0.1C \cdot V(μ A) or 3mA (J case:10 μ A) , whichever is greater				Voltage: Rated voltage for 5min.	
Dissipation Factor		Refer to Standard Ratings				at 120 Hz	
Equivalent Series Resistance		Refer to Standard Ratings				at 100 kHz	
		Capacitance change	DF(%)	L.C			
Surge voltage test		Refer to Standard Ratings	Lower than initial specification	Lower than initial specification		Temperature : 85 \pm 2°C Applied voltage : Surge voltage Series resistance : 33 ohm Duration of surge : 30 \pm 5 sec Time between surge : 5.5min. Number of cycle : 1000	
Characteristic at high and low temperature	-55°C	from 0 to -20%	Lower than initial specification	-----		Step 1: 25 \pm 2°C Step 2: -55 \pm 3°C Step 3: 25 \pm 2°C Step 4: 105 \pm 3°C	
	+105°C	from 0 to +50%	Lower than 1.5 times initial specification	Lower than 10 times initial specification			
Rapid change of temperature		Refer to Standard Ratings	Lower than initial specification	Lower than initial specification		Parts shall be temperature cycled over a temperature range of -55 to +105°C, five times continuously as follow. Step 1: -55 \pm 3°C, 30 \pm 3min. Step 2: room temp. , 10 to 15min. Step 3: 105 \pm 3°C, 30 \pm 3min. Step 4: room temp, 10 to 15min.	
Resistance to Soldering heat		Refer to Standard Ratings	Lower than 1.3 times initial specification	Lower than initial specification		Reflow soldering method 240°C, 10 sec.Max. *1	
Damp heat		from +30% to -20%	Lower than 1.5 times initial specification	Lower than initial specification		at 40°C at 90 to 95% RH 500 hour	
Endurance I		Refer to Standard Ratings	Lower than 1.5 times initial specification	Lower than initial specification		at 85°C at rated voltage 1000 hour	
Endurance II		Refer to Standard Ratings	Lower than 3 times initial specification	Lower than initial specification		at 105°C at Derated voltage 1000 hour	
Failure Rate		$\lambda_0 = 1\% / 1000$ hour				at 85°C: rated voltage at 105°C: derated voltage	
Terminal Strength		Visual: There shall be no evidence of mechanical damage				Strength : 4.9N Time : 10 \pm 0.5sec. (two directions)	
Permissible ripple current		Refer to Ratings Table				at 100 kHz	
Other		Conform to IEC60384-1				Conform to IEC60384-1	

*1: Refer to the page 47 "NOTES ON USING NeoCapacitor/2. Mounting/(1) Reflow soldering/(b) Temperature and time"

Reference : Derated voltage (85 to 105°C)

$$[U_T] = [U_R] - \frac{[U_R] - [U_C]}{20} (T-85)$$

[U_T] : Derated voltage at operating temperature[U_R] : Rated voltage[U_C] : Derated voltage at 105°C

T : Ambient temperature

■ STANDARD RATINGS

Rated Voltage (V)	Capacitance (μF)	Case Code	Part Number (Bulk)	Leakage Current (μA)	DF (%)	ESR (mΩ)	Permissible Ripple Current (mA rms.)	DF (%)		Capacitance Change	
								-5°C	+105°C	at Surge Voltage at Resistance to Soldering Heat	at Endurance
2.5	22	P	PSLP0E226M	5.5	6	200	354	6	9	±20%	±20%
	33	A2	PSLA20E336M	8.3	6	150	632	6	9	±20%	±20%
	47	A2	PSLA20E476M	11.7	6	150	632	6	9	±20%	±20%
	100	B3	PSLB30E107M	25	8	70	1035	8	12	±20%	±20%
	220	B2	PSLB20E227M	55	8	45	1374	8	12	±20%	±20%
	220	B2	PSLB20E227M(35)	55	8	35	1558	8	12	±20%	±20%
	220	B2	PSLB20E227M(25)	55	8	25	1844	8	12	±20%	±20%
	330	B2	PSLB20E337M	82.5	8	45	1374	8	12	±20%	±20%
	330	C	PSLC0E337M	82.5	10	55	1414	10	15	±20%	±20%
	330	C	PSLC0E337M(45)	82.5	10	45	1563	10	15	±20%	±20%
	330	C	PSLC0E337M(25)	82.5	10	25	2098	10	15	±20%	±20%
	330	C	PSLC0E337M(18)	82.5	10	18	2472	10	15	±20%	±20%
	330	V	PSLV0E337M	82.5	10	25	2236	10	15	±20%	±20%
	330	V	PSLV0E337M(15)	82.5	10	15	2887	10	15	±20%	±20%
	330	V	PSLV0E337M(12)	82.5	10	12	3227	10	15	±20%	±20%
	470	V	PSLV0E477M(15)	117.5	10	15	2887	10	15	±20%	±20%
	470	V	PSLV0E477M(12)	117.5	10	12	3227	10	15	±20%	±20%
	680	D	PSLD0E687M	170	10	25	2449	10	15	±20%	±20%
	680	D	PSLD0E687M(15)	170	10	15	3162	10	15	±20%	±20%
	680	D	PSLD0E687M(12)	170	10	12	3536	10	15	±20%	±20%
1000	D	PSLD0E108M	250	10	25	2449	10	15	±20%	±20%	
1000	D	PSLD0E108M(15)	250	10	15	3162	10	15	±20%	±20%	
4	10	J	PSLJ0G106M	10	4	300	183	4	6	±20%	±20%
	10	P	PSLP0G106M	4	6	200	354	6	9	±20%	±20%
	10	A	PSLA0G106M	4	6	200	612	6	9	±20%	±20%
	22	P	PSLP0G226M	8.8	6	200	354	6	9	±20%	±20%
	22	A2	PSLA20G226M	8.8	6	200	548	6	9	±20%	±20%
	22	B2	PSLB20G226M	8.8	8	150	753	8	12	±20%	±20%
	33	A2	PSLA20G336M	13.2	6	150	632	6	9	±20%	±20%
	33	A	PSLA0G336M	13.2	6	180	645	6	9	±20%	±20%
	47	A	PSLA0G476M	18.8	6	180	645	6	9	±20%	±20%
	47	B3	PSLB30G476M	18.8	8	70	1035	8	12	±20%	±20%
	68	A	PSLA0G686M	27.2	6	180	645	6	9	±20%	±20%
	68	C2	PSLC20G686M	27.2	8	55	1279	8	12	±20%	±20%
	68	C	PSLC0G686M	27.2	9	100	1049	9	14	±20%	±20%
	100	B3	PSLB30G107M	40	8	70	1035	8	12	±20%	±20%
	100	B2	PSLB20G107M	40	8	70	1102	8	12	±20%	±20%
	100	B2	PSLB20G107M(45)	40	8	45	1374	8	12	±20%	±20%
	100	B2	PSLB20G107M(35)	40	8	35	1558	8	12	±20%	±20%
	100	C2	PSLC20G107M	40	9	55	1279	9	14	±20%	±20%
	150	B2	PSLB20G157M	60	8	45	1374	8	12	±20%	±20%
	150	B2	PSLB20G157M(35)	60	8	35	1558	8	12	±20%	±20%
	150	B2	PSLB20G157M(25)	60	8	25	1844	8	12	±20%	±20%
	150	C	PSLC0G157M	60	9	100	1049	9	14	±20%	±20%
	220	B2	PSLB20G227M	88	8	45	1374	8	12	±20%	±20%
	220	C	PSLC0G227M	88	9	55	1414	9	14	±20%	±20%
	220	C	PSLC0G227M(45)	88	9	45	1563	9	14	±20%	±20%
	220	C	PSLC0G227M(25)	88	9	25	2098	9	14	±20%	±20%
	220	C	PSLC0G227M(18)	88	9	18	2472	9	14	±20%	±20%
	220	V	PSLV0G227M	88	10	45	1667	10	15	±20%	±20%
	220	V	PSLV0G227M(25)	88	10	25	2236	10	15	±20%	±20%
	220	V	PSLV0G227M(18)	88	10	18	2635	10	15	±20%	±20%
	220	V	PSLV0G227M(15)	88	10	15	2887	10	15	±20%	±20%
	220	V	PSLV0G227M(12)	88	10	12	3227	10	15	±20%	±20%
	220	D	PSLD0G227M	88	10	55	1651	10	15	±20%	±20%
	220	D	PSLD0G227M(40)	88	10	40	1936	10	15	±20%	±20%
	220	D	PSLD0G227M(25)	88	10	25	2449	10	15	±20%	±20%
	220	D	PSLD0G227M(15)	88	10	15	3162	10	15	±20%	±20%
	220	D	PSLD0G227M(12)	88	10	12	3536	10	15	±20%	±20%
	330	C	PSLC0G337M	132	10	55	1414	10	15	±20%	±20%
	330	V	PSLV0G337M	132	10	45	1667	10	15	±20%	±20%
	330	V	PSLV0G337M(25)	132	10	25	2236	10	15	±20%	±20%
330	V	PSLV0G337M(12)	132	10	12	3227	10	15	±20%	±20%	
330	D	PSLD0G337M	132	10	40	1936	10	15	±20%	±20%	
330	D	PSLD0G337M(25)	132	10	25	2449	10	15	±20%	±20%	

Rated Voltage (V)	Capacitance (μF)	Case Code	Part Number (Bulk)	Leakage Current (μA)	DF (%)	ESR (mΩ)	Permissible Ripple Current (mA rms.)	DF (%)		Capacitance Change	
								-5°C	+105°C	at Surge Voltage at Resistance to Soldering Heat	at Endurance
4	330	D	PSLD0G337M(15)	132	10	15	3162	10	15	±20%	±20%
	470	D	PSLD0G477M	188	10	25	2449	10	15	±20%	±20%
	470	D	PSLD0G477M(18)	188	10	18	2887	10	15	±20%	±20%
	470	D	PSLD0G477M(15)	188	10	15	3162	10	15	±20%	±20%
	470	D	PSLD0G477M(12)	188	10	12	3536	10	15	±20%	±20%
	470	D	PSLD0G477M(10)	188	10	10	3873	10	15	±20%	±20%
	680	D	PSLD0G687M	272	10	25	2449	10	15	±20%	±20%
	680	D	PSLD0G687M(15)	272	10	15	3162	10	15	±20%	±20%
680	D	PSLD0G687M(12)	272	10	12	3536	10	15	±20%	±20%	
6.3	2.2	J	PSLJ0J225M	10	4	500	141	4	6	±20%	±20%
	3.3	J	PSLJ0J335M	10	4	500	141	4	6	±20%	±20%
	3.3	P	PSLP0J335M	3	6	300	289	6	9	±20%	±20%
	4.7	J	PSLJ0J475M	10	4	500	141	4	6	±20%	±20%
	4.7	P	PSLP0J475M	3	6	300	289	6	9	±20%	±20%
	6.8	P	PSLP0J685M	4.2	6	300	289	6	9	±20%	±20%
	6.8	A	PSLA0J685M	4.2	6	300	500	6	9	±20%	±20%
	10	P	PSLP0J106M	6.3	6	200	354	6	9	±20%	±20%
	10	A2	PSLA20J106M	6.3	6	200	548	6	9	±20%	±20%
	10	A	PSLA0J106M	6.3	6	200	612	6	9	±20%	±20%
	15	A2	PSLA20J156M	9.4	6	200	548	6	9	±20%	±20%
	15	A	PSLA0J156M	9.4	6	200	612	6	9	±20%	±20%
	15	B2	PSLB20J156M	9.4	8	150	753	8	12	±20%	±20%
	22	A2	PSLA20J226M	13.8	6	200	548	6	9	±20%	±20%
	22	A	PSLA0J226M	13.8	6	180	645	6	9	±20%	±20%
	22	B3	PSLB30J226M	13.8	8	70	1035	8	12	±20%	±20%
	22	B2	PSLB20J226M	13.8	8	150	753	8	12	±20%	±20%
	33	A	PSLA0J336M	20.7	6	180	645	6	9	±20%	±20%
	33	B3	PSLB30J336M	20.7	8	70	1035	8	12	±20%	±20%
	33	B2	PSLB20J336M	20.7	8	150	753	8	12	±20%	±20%
	47	A	PSLA0J476M	29.6	6	180	645	6	9	±20%	±20%
	47	B3	PSLB30J476M	29.6	8	70	1035	8	12	±20%	±20%
	47	B3	PSLB30J476M(55)	29.6	8	55	1168	8	12	±20%	±20%
	47	B2	PSLB20J476M	29.6	8	150	753	8	12	±20%	±20%
	47	B2	PSLB20J476M(70)	29.6	8	70	1102	8	12	±20%	±20%
	47	C2	PSLC20J476M	29.6	9	70	1134	9	14	±20%	±20%
	47	C	PSLC0J476M	29.6	9	100	1049	9	14	±20%	±20%
	68	B3	PSLB30J686M	42.8	8	70	1035	8	12	±20%	±20%
	68	B2	PSLB20J686M	42.8	8	70	1102	8	12	±20%	±20%
	68	B2	PSLB20J686M(55)	42.8	8	55	1243	8	12	±20%	±20%
	68	C2	PSLC20J686M	42.8	9	55	1279	9	14	±20%	±20%
	68	C	PSLC0J686M	42.8	9	100	1049	9	14	±20%	±20%
	100	B2	PSLB20J107M	63	8	70	1102	8	12	±20%	±20%
	100	B2	PSLB20J107M(45)	63	8	45	1374	8	12	±20%	±20%
	100	B2	PSLB20J107M(35)	63	8	35	1558	8	12	±20%	±20%
	100	B2	PSLB20J107M(25)	63	8	25	1844	8	12	±20%	±20%
	100	C2	PSLC20J107M	63	9	70	1134	9	14	±20%	±20%
	100	C2	PSLC20J107M (55)	63	9	55	1279	9	14	±20%	±20%
	100	C	PSLC0J107M	63	9	100	1049	9	14	±20%	±20%
	100	C	PSLC0J107M(55)	63	9	55	1414	9	14	±20%	±20%
	150	B2	PSLB20J157M	94.5	8	45	1374	8	12	±20%	±20%
	150	C2	PSLC20J157M	94.5	9	55	1279	9	14	±20%	±20%
150	C	PSLC0J157M	94.5	9	100	1049	9	14	±20%	±20%	
150	C	PSLC0J157M(55)	94.5	9	55	1414	9	14	±20%	±20%	
150	C	PSLC0J157M(45)	94.5	9	45	1563	9	14	±20%	±20%	
150	C	PSLC0J157M(25)	94.5	9	25	2098	9	14	±20%	±20%	
150	V	PSLV0J157M	94.5	10	45	1667	10	15	±20%	±20%	
150	V	PSLV0J157M(25)	94.5	10	25	2236	10	15	±20%	±20%	
150	V	PSLV0J157M(18)	94.5	10	18	2635	10	15	±20%	±20%	
150	D	PSLD0J157M	94.5	10	55	1651	10	15	±20%	±20%	
150	D	PSLD0J157M(40)	94.5	10	40	1936	10	15	±20%	±20%	
150	D	PSLD0J157M(25)	94.5	10	25	2449	10	15	±20%	±20%	
220	V	PSLV0J227M	138.6	10	45	1667	10	15	±20%	±20%	
220	V	PSLV0J227M(25)	138.6	10	25	2236	10	15	±20%	±20%	
220	V	PSLV0J227M(15)	138.6	10	15	2887	10	15	±20%	±20%	
220	V	PSLV0J227M(12)	138.6	10	12	3227	10	15	±20%	±20%	

Conductive Polymer type

Rated Voltage (V)	Capacitance (μF)	Case Code	Part Number (Bulk)	Leakage Current (μA)	DF (%)	ESR (mΩ)	Permissible Ripple Current (mA rms.)	DF (%)		Capacitance Change	
								-5°C	+105°C	at Surge Voltage at Resistance to Soldering Heat	at Endurance
6.3	220	D	PSLD0J227M	138.6	10	55	1651	10	15	±20%	±20%
	220	D	PSLD0J227M(40)	138.6	10	40	1936	10	15	±20%	±20%
	330	V	PSLV0J337M	207.9	10	45	1667	10	15	±20%	±20%
	330	V	PSLV0J337M(25)	207.9	10	25	2236	10	15	±20%	±20%
	330	D	PSLD0J337M	207.9	10	40	1936	10	15	±20%	±20%
	330	D	PSLD0J337M(25)	207.9	10	25	2449	10	15	±20%	±20%
	330	D	PSLD0J337M(18)	207.9	10	18	2887	10	15	±20%	±20%
10	2.2	J	PSLJ1A225M	10	4	500	141	4	6	±20%	±20%
	3.3	A	PSLA1A335M	3.3	6	300	500	6	9	±20%	±20%
	4.7	A2	PSLA21A475M	4.7	6	300	447	6	9	±20%	±20%
	4.7	A	PSLA1A475M	4.7	6	300	500	6	9	±20%	±20%
	6.8	A2	PSLA21A685M	6.8	6	300	447	6	9	±20%	±20%
	6.8	A	PSLA1A685M	6.8	6	300	500	6	9	±20%	±20%
	6.8	B2	PSLB21A685M	6.8	8	200	652	8	12	±20%	±20%
	10	A2	PSLA21A106M	10	6	200	548	6	9	±20%	±20%
	10	A	PSLA1A106M	10	6	200	612	6	9	±20%	±20%
	10	B2	PSLB21A106M	10	8	200	652	8	12	±20%	±20%
	15	A	PSLA1A156M	15	6	180	645	6	9	±20%	±20%
	15	B2	PSLB21A156M	15	8	150	753	8	12	±20%	±20%
	15	C	PSLC1A156M	15	9	200	742	9	14	±20%	±20%
	22	A	PSLA1A226M	22	6	180	645	6	9	±20%	±20%
	22	B3	PSLB31A226M	22	8	70	1035	8	12	±20%	±20%
	22	B2	PSLB21A226M	22	8	150	753	8	12	±20%	±20%
	22	C	PSLC1A226M	22	9	150	856	9	14	±20%	±20%
	33	A	PSLA1A336M	33	8	200	612	8	12	±20%	±20%
	33	B3	PSLB31A336M	33	8	70	1035	8	12	±20%	±20%
	33	B2	PSLB21A336M	33	8	150	753	8	12	±20%	±20%
	33	C2	PSLC21A336M	33	9	70	1134	9	14	±20%	±20%
	33	C	PSLC1A336M	33	9	100	1049	9	14	±20%	±20%
	47	B3	PSLB31A476M	47	8	70	1035	8	12	±20%	±20%
	47	B2	PSLB21A476M	47	8	70	1102	8	12	±20%	±20%
	47	C2	PSLC21A476M	47	9	70	1134	9	14	±20%	±20%
	47	C	PSLC1A476M	47	9	100	1049	9	14	±20%	±20%
	47	C	PSLC1A476M(55)	47	9	55	1414	9	14	±20%	±20%
	47	V	PSLV1A476M	47	10	60	1443	10	15	±20%	±20%
	47	D	PSLD1A476M	47	10	100	1225	10	15	±20%	±20%
	68	C2	PSLC21A686M	68	9	55	1279	9	14	±20%	±20%
	68	C	PSLC1A686M	68	9	100	1049	9	14	±20%	±20%
	68	C	PSLC1A686M(55)	68	9	55	1414	9	14	±20%	±20%
	68	V	PSLV1A686M	68	10	60	1443	10	15	±20%	±20%
68	D	PSLD1A686M	68	10	100	1225	10	15	±20%	±20%	
100	V	PSLV1A107M	100	10	45	1667	10	15	±20%	±20%	
100	V	PSLV1A107M(25)	100	10	25	2236	10	15	±20%	±20%	
100	C2	PSLC21A107M	100	9	70	1134	9	14	±20%	±20%	
100	C2	PSLC21A107M(55)	100	9	55	1279	9	14	±20%	±20%	
100	C	PSLC1A107M	100	9	100	1049	9	14	±20%	±20%	
100	C	PSLC1A107M(55)	100	9	55	1414	9	14	±20%	±20%	
100	D	PSLD1A107M	100	10	55	1651	10	15	±20%	±20%	
150	C	PSLC1A157M	150	9	55	1414	9	14	±20%	±20%	
150	V	PSLV1A157M	150	10	45	1667	10	15	±20%	±20%	
150	V	PSLV1A157M(40)	150	10	40	1768	10	15	±20%	±20%	
150	D	PSLD1A157M	150	10	55	1651	10	15	±20%	±20%	
150	D	PSLD1A157M(40)	150	10	40	1936	10	15	±20%	±20%	
220	D	PSLD1A227M	220	10	55	1651	10	15	±20%	±20%	
220	D	PSLD1A227M(40)	220	10	40	1936	10	15	±20%	±20%	
220	D	PSLD1A227M(25)	220	10	25	2449	10	15	±20%	±20%	
16	3.3	A	PSLA1C335M	5.2	6	800	306	6	9	±20%	±20%
	4.7	B2	PSLB21C475M	7.5	8	200	652	8	12	±20%	±20%
	6.8	B2	PSLB21C685M	10.8	8	200	652	8	12	±20%	±20%
	10	B2	PSLB21C106M	16	8	100	922	8	12	±20%	±20%
	33	V	PSLV1C336M	52.8	10	70	1336	10	15	±20%	±20%
	47	V	PSLV1C476M	75.2	10	70	1336	10	15	±20%	±20%
47	D	PSLD1C476M	75.2	10	70	1464	10	15	±20%	±20%	