

# SMFLHP Single and Dual DC/DC Converters

## 28 VOLT INPUT – 100 WATT

### FEATURES

Parallel operation with current share, up to 3 units (up to 285 watts)

- Operating temperature -55° to +125°C
- Qualified to MIL-PRF-38534 Class H and K
- Radiation hardness assurance (RHA) to level R 100 kRad(Si)
- Input voltage range 19 to 40 VDC
- Transient protection 80 V for 50 ms
- Fully isolated, magnetic feedback
- Fixed high frequency switching
- Remote sense / output trim on single output models
- Inhibit function
- Synchronization input and output
- Indefinite short circuit protection
- High power density with up to 87% efficiency



MODELS	
VDC OUTPUT	
SINGLE	DUAL
3.3	±5
5	±12
12	±15
15	

### DESCRIPTION

The Interpoint™ SMFLHP Series™ 28 volt DC/DC converters are rated up to 100 watts output power over a -55°C to +125°C temperature range with a 28 VDC nominal input. On dual output models, up to 70% of the rated output power can be drawn from either the positive or negative outputs. Current sharing allows the units to be paralleled for total power of up to 285 watts. The welded, hermetically sealed package is only 3.005 x 1.505 x 0.400 inches, giving the series an overall power density of up to 67 watts per cubic inch.

### SCREENING

SMFLHP converters offer screening options to Space Prototype (O), Class H, or Class K. Radiation tolerant to Radiation Hardness Assurance (RHA) levels of “-” (O), “P” or “R”, per MIL-PRF-38534. Interpoint model numbers use an “O” in the RHA designator position to indicate the “-” (dash) Radiation Hardness Assurance level of MIL-PRF-38534, which is defined as “no RHA”. See Screening Tables 1 and 2 for more information.

### DESIGN FEATURES

The SMFLHP Series converters are switching regulators that use a quasi-square wave, single ended forward converter design with a constant switching frequency of 600 kHz.

Isolation between input and output circuits is provided with a transformer in the forward path and wide bandwidth magnetic coupling in the feedback control loop. The SMFLHP Series uses a unique dual loop feedback technique that controls output current with an inner feedback loop and output voltage with a cascaded voltage mode feedback loop.

The additional secondary current mode feedback loop improves transient response in a manner similar to primary current mode control and allows for ease of paralleling.

Tight load regulation is achieved through a wide-bandwidth magnetic feedback circuit. The output voltage on single SMFLHP models can be easily trimmed up by adding an external resistor. (See Figure 1 for voltage changes with different resistor values.)

### INHIBIT

The SMFLHP Series converters have two inhibit terminals (INH1 and INH2) that can be used to disable power conversion, resulting in a very low quiescent input current. An active low (<0.8 volts) is required between INH1 (pin 4) and Input Common (pin 2) to inhibit the converter. An active low (<0.5 volts) is required between INH2 (pin 12) and Output Common (pin 8) to inhibit the converter. The application of intermediate voltages to these pins (1.5 to 10.5 volts) should be avoided.

### CURRENT SHARING AND PARALLEL OPERATION

Multiple SMFLHP converters may be used in parallel to drive a common load (see Figure 2). Only single output models with SENSE and SNS RTN can be used in the share mode. In this mode of operation the load current is shared by two or three SMFLHP converters. In current sharing mode, one SMFLHP converter is designated as a master. The SLAVE pin (pin 11) of the master is left unconnected and the MSTR/INH2 pin (pin 12) of the master is connected to the SLAVE pin (pin 11) of the slave units. The units designated as slaves have the MSTR/INH2 pin (pin 12) connected to the SNS RTN pin (pin 9) of the master unit. Figure 2 shows the typical setup for two or three units in parallel.

# SMFLHP Single and Dual DC/DC Converters

## 28 VOLT INPUT – 100 WATT

Note that synchronizing the units together (though shown in the figure) is not required for current sharing operation. A second slave unit may be placed in parallel with a master and slave; this requires the TRI pin (pin 3) of the master unit to be connected to the SNS RTN pin (pin 9).

When paralleled, up to 95% of the total combined power ratings of the SMFLHP converters is available at the load. Overload and short circuit performance are not adversely affected during parallel operation.

### OPERATING CONDITIONS AND CHARACTERISTICS

#### Input Voltage Range

- 19 to 40 VDC continuous
- 80 V for 50 msec transient

#### Output Power

- Up to 100 watts depending on model

#### Lead Soldering Temperature (10 sec per lead)

- 300°C

#### Storage Temperature Range (Case)

- -65°C to +150°C

#### Power Dissipation (Pd)

- 20 watts

#### Case Operating Temperature (Tc)

- -55°C to +125°C full power
- -55°C to +135°C absolute

#### Derating Output Power/Current

- Linearly from 100% at 125°C to 0% at 135°C

#### Output Voltage Temperature Coefficient

- 100 ppm/°C typical

#### Input to Output Capacitance

- 150 pF typical

#### Isolation

- 100 megohm minimum at 500 VDC, any pin to case

#### Audio Rejection

- 50 dB typical

#### Conversion Frequency

- Free run mode 600 kHz typical
  - 550 kHz min, 650 kHz. max
- External sync range 525 to 675 kHz

### MECHANICAL AND ENVIRONMENTAL

#### Size (maximum)

- 3.005 x 1.505 x 0.400 inches (76.33 x 38.23 x 10.16 mm).  
Case U has short, straight leads. Case V has longer leads which are bent down.

#### Weight (maximum)

- 86 grams

### SYNC AND INHIBIT (INH1, INH2)

#### Sync

- Sync In
  - Input frequency 525 to 675 Hz.
  - Duty cycle 40% min, 60% max
  - Active low 0.8 V max
  - Active high 4.5 V min, 5 V max
  - Referenced to input common
- Sync Out
  - Referenced to input common

#### Inhibit: INH1 and INH2

##### (do not apply a voltage to the inhibit pin)

- Converter Disabled (active low)
  - INH1 referenced to input common
    - Pull voltage to 0.8 V or below by connecting to ground or other method.
    - Inhibit pin source current, 10 mA max
  - INH2 referenced to output common
    - Pull voltage to 0.5 V or below by connecting to ground or other method.
    - Inhibit pin source current 5 mA max
- Converter Enabled (active high)
  - Inhibit pin open or through an open collector
  - Open pin voltage
    - INH1 = 9 to 12 V
    - INH2 = 9 V max

#### Screening

Space Prototype (O), Class H, or Class K Radiation tolerant to Radiation Hardness Assurance (RHA) levels of “-” (O), “P” or “R”, per MIL-PRF-38534. Interpoint model numbers use an “O” in the RHA designator position to indicate the “-” (dash) Radiation Hardness Assurance level of MIL-PRF-38534, which is defined as “no RHA”.

- Available configurations: OO, HP, KP, HR, KR
- See Screening Tables 1 and 2 for more information.

# SMFLHP Single and Dual DC/DC Converters

## 28 VOLT INPUT – 100 WATT

### SINGLE OUTPUT MODELS CONNECTION DIAGRAMS - SENSE, TRIM AND PARALLEL

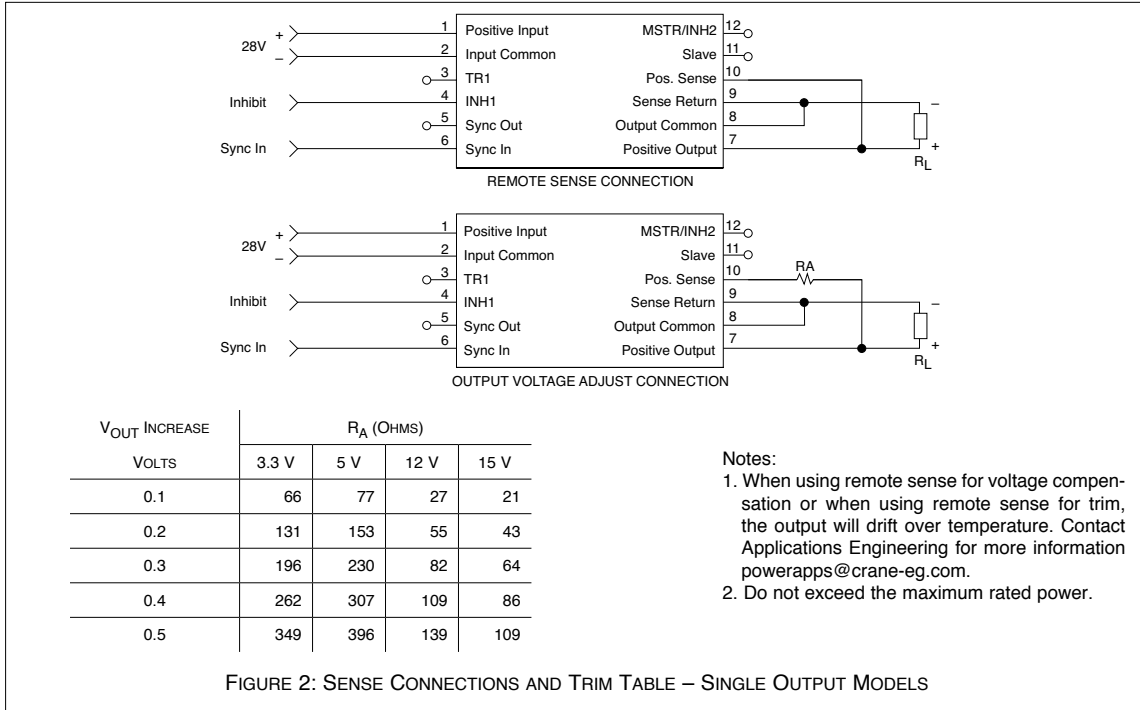

FIGURE 2: SENSE CONNECTIONS AND TRIM TABLE – SINGLE OUTPUT MODELS

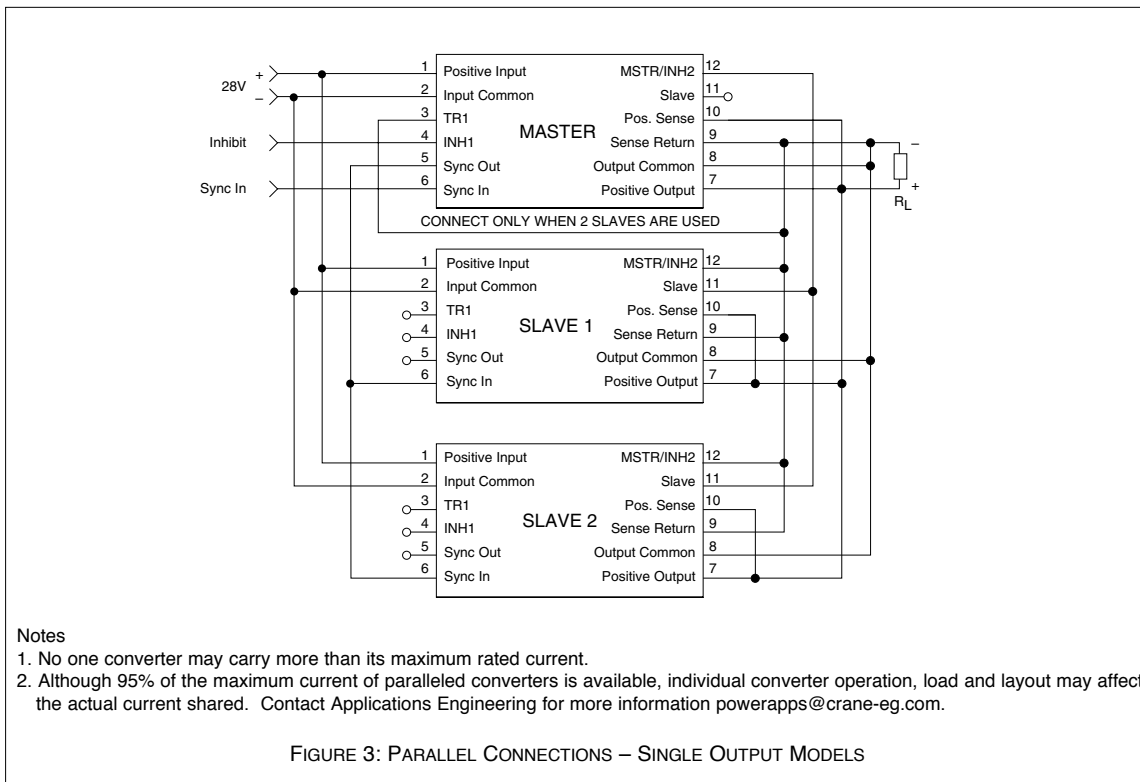

FIGURE 3: PARALLEL CONNECTIONS – SINGLE OUTPUT MODELS

# SMFLHP Single and Dual DC/DC Converters

## 28 VOLT INPUT – 100 WATT

PIN OUT		
Pin	Single Output	Dual Output
1	Positive Input	Positive Input
2	Input Common	Input Common
3	Triple (TR1)	Triple (TR1)
4	Inhibit 1 (INH1)	Inhibit 1 (INH1)
5	Sync Out	Sync Out
6	Sync In	Sync In
7	Positive Output	Positive Output
8	Output Common	Output Common
9	Sense Return	Negative Output
10	Positive Sense	No connection
11	Slave	Slave
12	Master/Inhibit 2 (MSTR/INH2)	Master/Inhibit 2 (MSTR/INH2)

PINS NOT IN USE		
Pin	Description	Action
3	TR1	Leave unconnected
4	Inhibit 1 (INH1)	Leave unconnected
5	Sync Out	Leave unconnected
6	Sync In	Connect to Input Common
9	Sense Return	Connect to appropriate outputs
10	Positive Sense	Connect to appropriate outputs
11	Slave	Leave unconnected
12	Master/Inhibit 2 (MSTR/INH2)	Leave unconnected

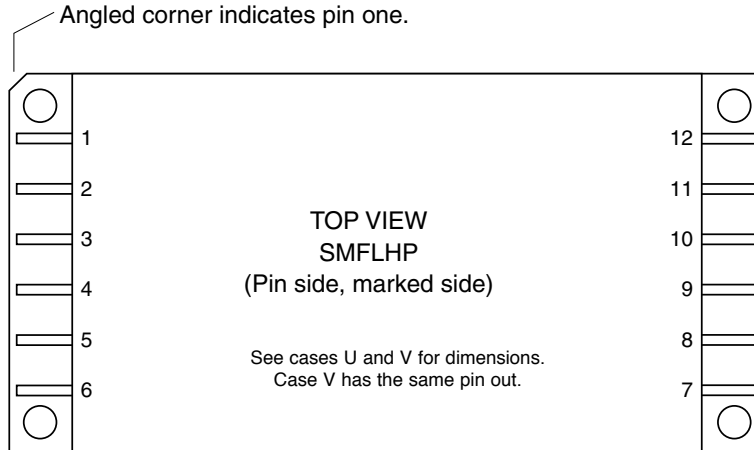
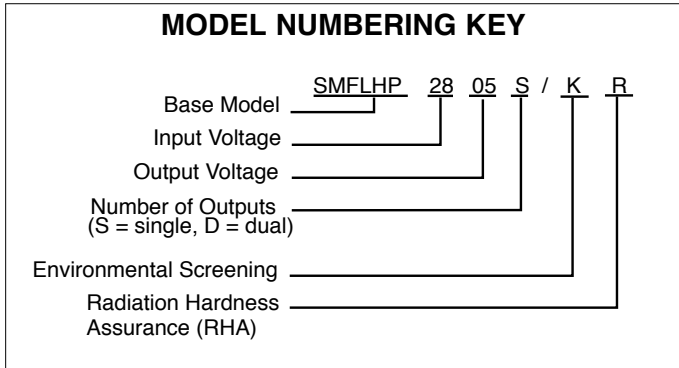

FIGURE 1: PIN OUT

# SMFLHP Single and Dual DC/DC Converters

## 28 VOLT INPUT – 100 WATT



**SMD NUMBERS**

STANDARD MICROCIRCUIT DRAWING (SMD)	SMFLHP SERIES SIMILAR PART
5962R0620901KXC	SMFLHP283R3S/KR
5962R0822301KXC	SMFLHP2815D/KR

The SMD number shown is for Class H screening, non-flanged, and no Radiation Hardness Assurance (RHA) level. See the SMD for the numbers for other screening and RHA levels. For exact specifications for an SMD product, refer to the SMD drawing. SMDs can be down-loaded from: <http://www.dscclia.mil/programs/smcr>

<b>MODEL SELECTION</b>							
<b>ON THE LINES BELOW, ENTER ONE SELECTION FROM EACH CATEGORY TO DETERMINE THE MODEL NUMBER.</b>							
<b>CATEGORY</b>	<b>SMFLHP28</b>	_____	_____	_____	/	_____	_____
	Base Model and Input Voltage	Output Voltage <sup>1</sup>	Number of Outputs <sup>2</sup>	Case/Lead Options <sup>3</sup>		Screening <sup>4</sup>	RHA <sup>5</sup>
<b>SELECTION</b>	SMFL28 is the only available option	<b>3R3, 05, 12, 15</b>	<b>S</b>	(U, leave blank)		<b>O</b>	<b>O</b>
		<b>05, 12, 15</b>	<b>D</b>	<b>V</b>		<b>H</b>	<b>P</b>
						<b>K</b>	<b>R</b>

- Notes:
1. Output Voltage: An R indicates a decimal point. 3R3 is 3.3 volts out.
  2. Number of Outputs: S is a single output and D is a dual output
  3. Case Options: For the standard case (case U) leave the case option blank. For case option V, insert the letter V in the case option position.
  4. Screening: A screening level of O is a Space Prototype and is only used with RHA O. See Screening Tables 1 and 2 for more information.
  5. RHA: Interpoint model numbers use an "O" in the RHA designator position to indicate the "-" (dash) Radiation Hardness Assurance level of MIL-PRF-38534, which is defined as "no RHA." RHA O is only available with Screening level O. See Screening Table 2 for more information.

# SMFLHP Single and Dual DC/DC Converters

## 28 VOLT INPUT – 100 WATT

Electrical Characteristics:  $-55^{\circ}\text{C}$  to  $+125^{\circ}\text{C}$   $T_C$ , 28 VDC  $V_{in}$ , 100% load, free run, unless otherwise specified.

SINGLE OUTPUT MODELS		SMFLHP283R3S			SMFLHP2805S			UNITS
PARAMETER	CONDITIONS	MIN	TYP	MAX	MIN	TYP	MAX	
OUTPUT VOLTAGE		3.23	3.30	3.37	4.875	5.00	5.125	VDC
OUTPUT CURRENT	$V_{in} = 19$ TO 40 VDC	0	—	16	0	—	16	A
OUTPUT POWER	$V_{in} = 19$ TO 40 VDC	0	—	53	0	—	80	W
OUTPUT RIPPLE 10 kHz - 2 MHz	$T_C = 25^{\circ}\text{C}$	—	10	25	—	15	50	mV p-p
	$T_C = -55^{\circ}\text{C}$ TO $+125^{\circ}\text{C}$	—	20	40	—	30	90	
LINE REGULATION	$V_{in} = 19$ TO 40 VDC	—	0	50	—	0	50	mV
LOAD REGULATION	NO LOAD TO FULL	—	0	20	—	0	20	mV
INPUT VOLTAGE NO LOAD TO FULL	CONTINUOUS	19	28	40	19	28	40	VDC
	TRANSIENT <sup>1, 2</sup> 50 ms	—	—	80	—	—	80	V
INPUT CURRENT	NO LOAD	—	70	120	—	70	120	mA
	INHIBITED - INH1	—	9	15	—	9	15	
	INHIBITED - INH2	—	35	80	—	35	80	
INPUT RIPPLE CURRENT	10 kHz - 10 MHz	—	30	80	—	30	80	mA p-p
EFFICIENCY	$T_C = 25^{\circ}\text{C}$	70	72	—	76	80	—	%
	$T_C = -55^{\circ}\text{C}$ TO $+125^{\circ}\text{C}$	65	—	—	74	—	—	
LOAD FAULT	SHORT CIRCUIT POWER DISSIPATION	—	15	24	—	15	22	W
	RECOVERY <sup>1</sup>	—	1.5	10	—	1.5	4	ms
STEP LOAD RESPONSE	50% - 100% - 50% TRANSIENT	—	$\pm 350$	$\pm 400$	—	$\pm 350$	$\pm 400$	mV pk
	RECOVERY <sup>1, 3</sup>	—	1.5	3.0	—	1.5	3.0	ms
STEP LINE RESPONSE <sup>1</sup>	19 - 40 - 19 VDC TRANSIENT	—	$\pm 250$	$\pm 400$	—	$\pm 250$	$\pm 400$	mV pk
	RECOVERY <sup>3</sup>	—	200	300	—	200	600	$\mu\text{s}$
START-UP	DELAY	—	3.5	10	—	3.5	10	ms
	OVERSHOOT <sup>1</sup>	—	0	50	—	0	25	mV pk

### Notes

**1. Guaranteed by design, not tested.**

2. Unit will shut down above approximately 45V but will be undamaged and will restart when voltage drops into normal range.

3. Recovery time is measured from application of the transient to point at which  $V_{out}$  is within 1% of final value.

# SMFLHP Single and Dual DC/DC Converters

## 28 VOLT INPUT – 100 WATT

Electrical Characteristics: -55°C to +125°C T<sub>C</sub>, 28 VDC V<sub>in</sub>, 100% load, free run, unless otherwise specified.

SINGLE OUTPUT MODELS		SMFLHP2812S			SMFLHP2815S			UNITS
PARAMETER	CONDITIONS	MIN	TYP	MAX	MIN	TYP	MAX	
OUTPUT VOLTAGE		11.76	12.00	12.24	14.55	15.00	15.45	VDC
OUTPUT CURRENT	V <sub>IN</sub> = 19 TO 40 VDC	0	—	7.5	0	—	6.67	A
OUTPUT POWER	V <sub>IN</sub> = 19 TO 40 VDC	0	—	90	0	—	100	W
OUTPUT RIPPLE 10 kHz - 2 MHz	T <sub>C</sub> = 25°C	—	30	85	—	30	95	mV p-p
	T <sub>C</sub> = -55°C TO +125°C	—	45	150	—	45	175	
LINE REGULATION	V <sub>IN</sub> = 19 TO 40 VDC	—	0	50	—	0	50	mV
LOAD REGULATION	NO LOAD TO FULL	—	0	20	—	0	20	mV
INPUT VOLTAGE NO LOAD TO FULL	CONTINUOUS	19	28	40	19	28	40	VDC
	TRANSIENT <sup>1, 2</sup> 50 ms	—	—	80	—	—	80	V
INPUT CURRENT	NO LOAD	—	80	120	—	80	120	mA
	INHIBITED - INH1	—	9	15	—	9	15	
	INHIBITED - INH2	—	35	80	—	35	80	
INPUT RIPPLE CURRENT	10 kHz - 10 MHz	—	30	80	—	30	80	mA p-p
EFFICIENCY	T <sub>C</sub> = 25°C	81	86	—	82	87	—	%
	T <sub>C</sub> = -55°C TO +125°C	79	—	—	80	—	—	
LOAD FAULT	SHORT CIRCUIT POWER DISSIPATION	—	15	22	—	15	30	W
	RECOVERY <sup>1</sup>	—	1.5	4	—	1.5	4	ms
STEP LOAD RESPONSE	50% - 100% - 50% TRANSIENT	—	±450	±700	—	±450	±700	mV pk
	RECOVERY <sup>1, 3</sup>	—	1.5	3.0	—	1.5	3.0	ms
STEP LINE RESPONSE <sup>1</sup>	19 - 40 - 19 VDC TRANSIENT	—	±250	±800	—	±250	±800	mV pk
	RECOVERY <sup>3</sup>	—	200	600	—	200	600	μs
START-UP	DELAY	—	3.5	10	—	3.5	10	ms
	OVERSHOOT <sup>1</sup>	—	0	50	—	0	50	mV pk

### Notes

**1. Guaranteed by design, not tested.**

2. Unit will shut down above approximately 45V but will be undamaged and will restart when voltage drops into normal range.

3. Recovery time is measured from application of the transient to point at which V<sub>out</sub> is within 1% of final value.

# SMFLHP Single and Dual DC/DC Converters

## 28 VOLT INPUT – 100 WATT

Electrical Characteristics: -55°C to +125°C T<sub>C</sub>, 28 VDC Vin, 100% load, free run, unless otherwise specified.

DUAL OUTPUT MODELS		SMFLHP2805D			SMFLHP2812D			SMFLHP2815D			UNITS
PARAMETER	CONDITIONS	MIN	TYP	MAX	MIN	TYP	MAX	MIN	TYP	MAX	
OUTPUT VOLTAGE	+ V <sub>OUT</sub>	4.85	5.00	5.15	11.64	12.00	12.36	14.55	15.00	15.45	VDC
	- V <sub>OUT</sub>	4.82	5.00	5.18	11.58	12.00	12.42	14.47	15.00	15.53	
OUTPUT CURRENT <sup>2</sup> V <sub>IN</sub> = 19 TO 40 VDC	EACH OUTPUT	0	±8	11.2	0	±3.75	5.3	0	±3.33	4.67	A
	TOTAL	—	—	16.0	0	—	7.5	0	—	6.67	
OUTPUT POWER <sup>2</sup> V <sub>IN</sub> = 19 TO 40 VDC	EACH OUTPUT	0	±40	56	0	±45	63	0	±50	70	W
	TOTAL	0	—	80	0	—	90	0	—	100	
OUTPUT RIPPLE 10 kHz - 2 MHz	+ V <sub>OUT</sub>	—	25	150	—	50	175	—	50	225	mV p-p
	- V <sub>OUT</sub>	—	25	150	—	50	75	—	50	225	
LINE REGULATION V <sub>IN</sub> = 19 TO 40 VDC	+ V <sub>OUT</sub>	—	0	50	—	0	50	—	0	50	mV
	- V <sub>OUT</sub>	—	25	100	—	25	100	—	25	100	
LOAD REGULATION NO LOAD TO FULL	+ V <sub>OUT</sub>	—	0	50	—	10	100	—	10	100	mV
	- V <sub>OUT</sub>	—	25	100	—	50	200	—	50	200	
CROSS REGULATION T <sub>C</sub> = 25°C	SEE NOTE 3	—	6	8	—	2	4	—	2	4	%
	SEE NOTE 4	—	7	8	—	2	4	—	2	4	
INPUT VOLTAGE NO LOAD TO FULL	CONTINUOUS	19	28	40	19	28	40	19	28	40	VDC
	TRANSIENT <sup>1, 5</sup> 50 ms	0	—	80	0	—	80	0	—	80	V
INPUT CURRENT	NO LOAD	—	50	120	—	50	120	—	50	120	mA
	INHIBITED - INH1	—	9	14	—	9	14	—	9	14	
	INHIBITED - INH2	—	35	80	—	35	80	—	35	80	
INPUT RIPPLE CURRENT	10 kHz - 10 MHz	—	30	80	—	30	80	—	30	80	mA p-p
EFFICIENCY	T <sub>C</sub> = 25°C	75	80	—	81	86	—	82	87	—	%
BALANCED LOAD	T <sub>C</sub> = -55°C TO +125°C	73	—	—	82	—	—	80	—	—	
LOAD FAULT	POWER DISSIPATION SHORT CIRCUIT	—	15	25	—	15	22	—	15	21	W
	RECOVERY <sup>1, 6</sup>	—	1.5	4.0	—	1.5	4.0	—	1.5	4.0	ms
STEP LOAD RESPONSE ± V <sub>OUT</sub> , 50% - 100% - 50%	TRANSIENT	—	±350	±450	—	±450	±700	—	±450	±700	mV pk
	RECOVERY <sup>1, 6</sup>	—	1.5	3.0	—	1.5	3.0	—	1.5	3.0	ms
STEP LINE RESPONSE <sup>1</sup> ± V <sub>OUT</sub> , 19 - 40 -19 VDC	TRANSIENT <sup>1</sup>	—	±250	±600	—	±250	±800	—	±250	±800	mV pk
	RECOVERY <sup>1, 6</sup>	—	200	300	—	200	600	—	200	600	μs
START-UP	DELAY	—	3.5	20	—	3.5	20	—	3.5	20	ms
	OVERSHOOT <sup>1</sup>	—	0	25	—	0	50	—	0	50	mV pk

### Notes

1. Guaranteed by design, not tested.

2. Up to 70% of the total output power (current) is available from either output provided the opposite output is carrying 30% of the power (current) in use.

3. Effect on negative V<sub>out</sub> from 50%/50% loads to 30%/70% or 70%/30% loads.

4. Effect on negative V<sub>out</sub> from 50%/50% loads to 10% then 50% load on negative V<sub>out</sub>

5. Unit will shut down above approximately 45V but will be undamaged and will restart when voltage drops into normal range.

6. Recovery time is measured from application of the transient to point at which V<sub>out</sub> is within 1% of final value.



# SMFLHP Single and Dual DC/DC Converters

## 28 VOLT INPUT – 100 WATT

Typical Performance Curves: 25°C Tc , 28 VDC Vin, 100% load, free run, unless otherwise specified.

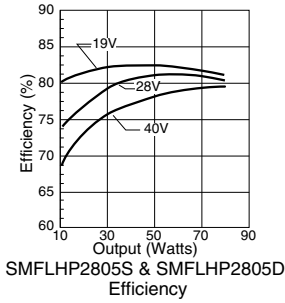

FIGURE 4

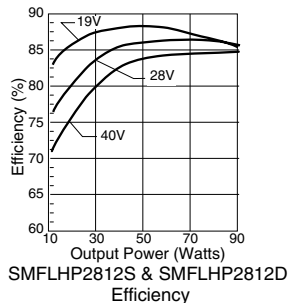

FIGURE 5

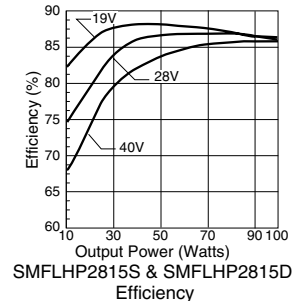

FIGURE 6

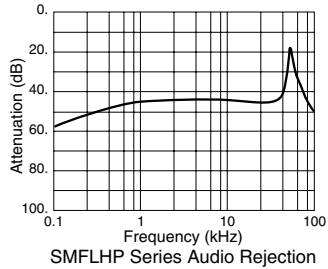

FIGURE 7

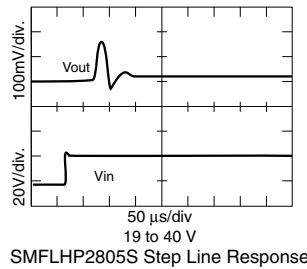

FIGURE 8

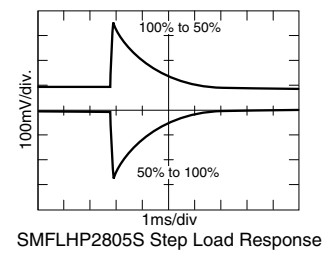

FIGURE 9

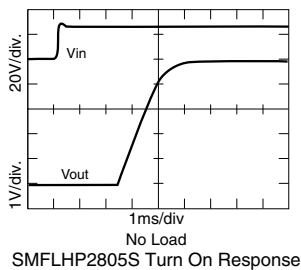

FIGURE 10

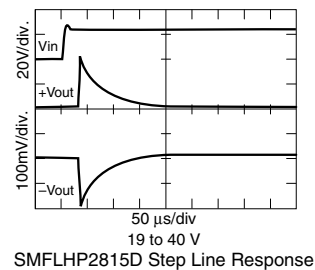

FIGURE 11

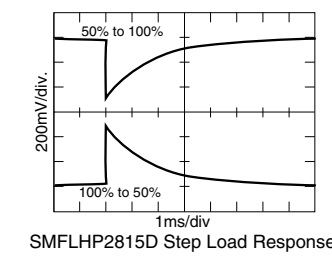
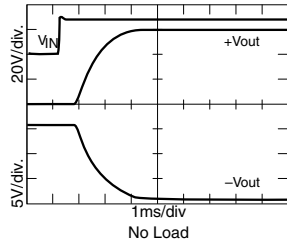

FIGURE 12

# SMFLHP Single and Dual DC/DC Converters

## 28 VOLT INPUT – 100 WATT

Typical Performance Curves: 25°C Tc , 28 VDC Vin, 100% load, free run, unless otherwise specified.



SMFLHP2815D Turn On Response

FIGURE 13

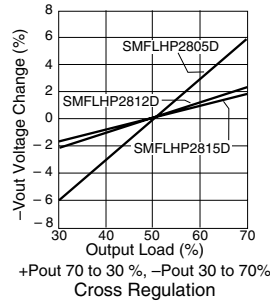

FIGURE 14

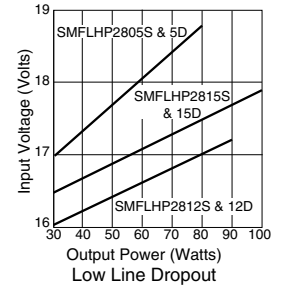
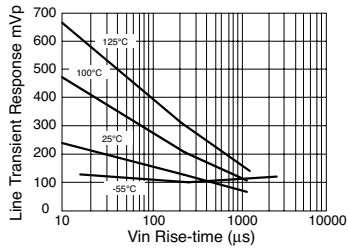

FIGURE 15



SMFLHP2815D Line Transient Response vs. Vin Rise-time

FIGURE 16

# SMFLHP Single and Dual DC/DC Converter Cases

## 28 VOLT INPUT – 100 WATT

### TOP VIEW CASE U\* Flanged case, short-leaded

\*Does not require designator in Case Option position of model number.

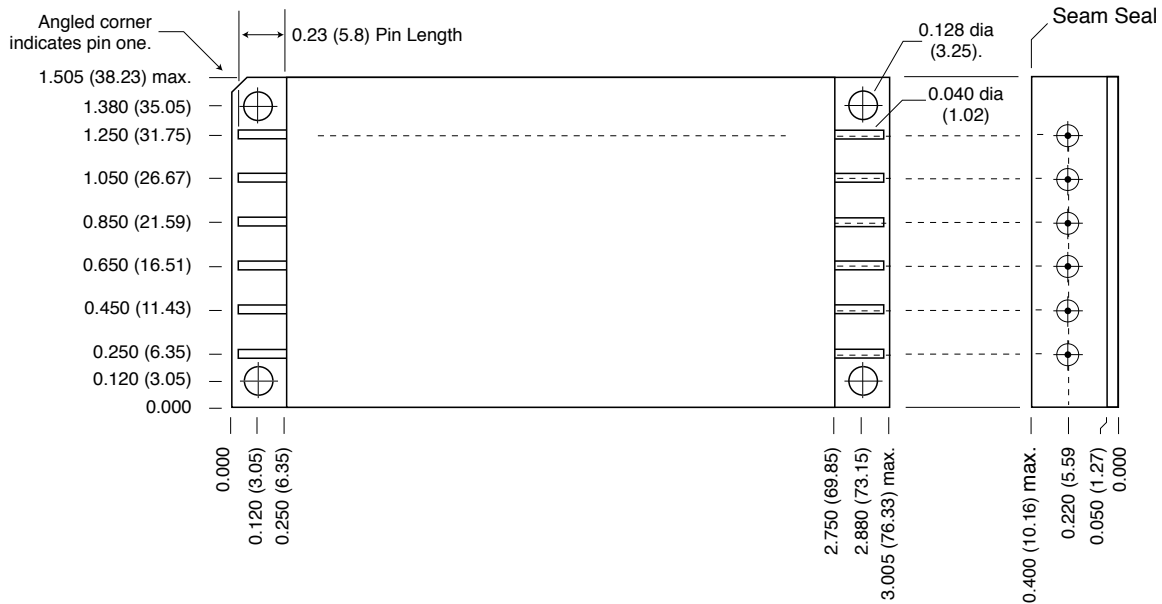

#### Case dimensions in inches (mm)

Tolerance  $\pm 0.005$  (0.13) for three decimal places  
 $\pm 0.01$  (0.3) for two decimal places  
 unless otherwise specified

#### CAUTION

Heat from reflow or wave soldering may damage the device. Solder pins individually with heat application not exceeding 300°C for 10 seconds per pin.

#### Materials

Header Cold Rolled Steel/Nickel/Gold  
 Cover Kovar/Nickel  
 Pins #52 alloy/Gold, compression glass seal  
 Seal Hole:  $0.100 \pm 0.002$  ( $2.54 \pm 0.05$ )

Case U, Rev F, 20100503

FIGURE 17: CASE U

# SMFLHP Single and Dual DC/DC Converter Cases

## 28 VOLT INPUT – 100 WATT

### TOP VIEW CASE V\* Flanged case, down leaded

\*Designator "V" required in Case Option position of model number.

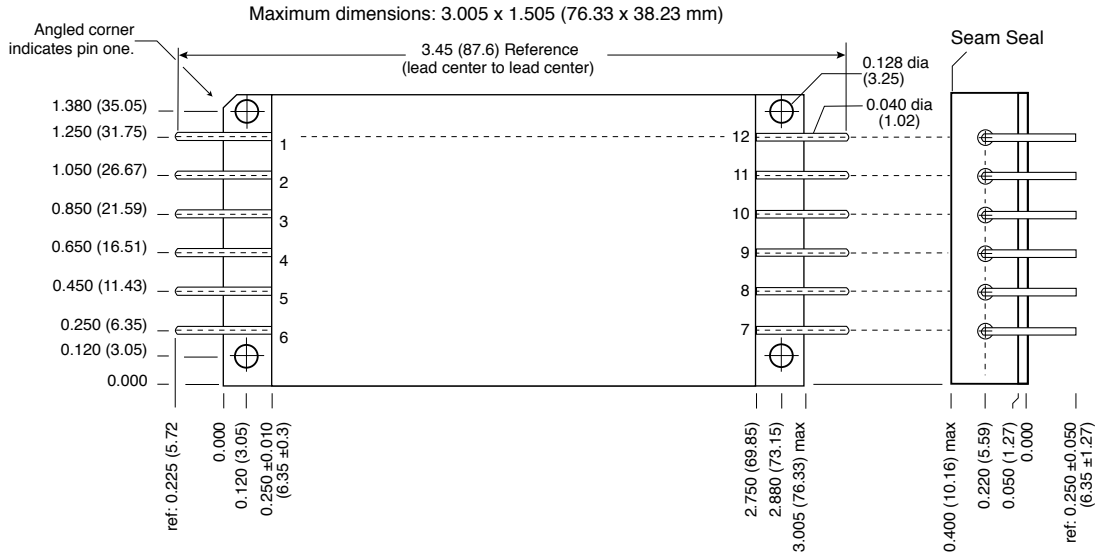

**Case dimensions in inches (mm)**

Tolerance ±0.005 (0.13) for three decimal places  
±0.01 (0.3) for two decimal places  
unless otherwise specified

**CAUTION**

Heat from reflow or wave soldering may damage the device. Solder pins individually with heat application not exceeding 300°C for 10 seconds per pin.

**Materials**

Header Cold Rolled Steel/Nickel/Gold  
Cover Kovar/Nickel  
Pins #52 alloy/Gold, compression glass seal  
Seal Hole: 0.120 ±0.002 (3.05 ±0.05)

Case V, Rev F, 2010624  
Please refer to the numerical dimensions for accuracy.

FIGURE 18: CASE V

# SMFLHP Single and Dual DC/DC Converters

## 28 VOLT INPUT – 100 WATT

### CLASS H AND K, MIL-PRF-38534 ELEMENT EVALUATION

COMPONENT-LEVEL TEST PERFORMED	SPACE PROTOTYPE (O) <sup>1</sup> NON-QML	/H CLASS H QML		/K CLASS K QML	
	M/S <sup>2</sup>	M/S <sup>2</sup>	P <sup>3</sup>	M/S <sup>2</sup>	P <sup>3</sup>
Element Electrical	■	■	■	■	■
Visual		■	■	■	■
Internal Visual		■		■	
Temperature Cycling				■	■
Constant Acceleration				■	■
Interim Electrical				■	
Burn-in				■	
Post Burn-in Electrical				■	
Steady State Life				■	
Voltage Conditioning Aging					■
Visual Inspection					■
Final Electrical		■	■	■	■
Wire Bond Evaluation		■	■	■	■
SEM				■	
C-SAM: Input capacitors only Add'l test, not req. by H or K			■		■

Notes:

1. Non-QML products may not meet all of the requirements of MIL-PRF-38534.
2. M/S = Active components (Microcircuit and Semiconductor Die)
3. P = Passive components, Class H and K element evaluation. Not applicable to Space Prototype ("O") element evaluation.

Definitions:

Element Evaluation: Component testing/screening per MIL-STD-883 as determined by MIL-PRF-38534

SEM: Scanning Electron Microscopy

C-SAM: C - Mode Scanning Acoustic Microscopy

SCREENING TABLE 1: ELEMENT EVALUATION

# SMFLHP Single and Dual DC/DC Converters

## 28 VOLT INPUT – 100 WATT

### CLASS H AND K, MIL-PRF-38534 ENVIRONMENTAL SCREENING AND RHA<sup>1</sup>

TEST PERFORMED	NON-QML <sup>2</sup>	QML <sup>3</sup>			
		CLASS H		CLASS K	
	/OO	/HP	/HR	/KP	/KR
Non-destruct bond pull, Method 2023		■ <sup>4</sup>	■ <sup>4</sup>	■	■
Pre-cap Inspection, Method 2017, 2032	■	■	■	■	■
Temperature Cycle (10 times) Method 1010, Cond. C, -65°C to +150°C, ambient	■	■	■	■	■
Constant Acceleration Method 2001, 3000 g (Qual 5000 g)	■	■	■	■	■
PIND, Test Method 2020, Cond. A		■ <sup>4</sup>	■ <sup>4</sup>	■	■
Pre burn-in test, Group A, Subgroups 1 and 4	■	■ <sup>4</sup>	■ <sup>4</sup>	■	■
Burn-in Method 1015, +125°C case, typical <sup>5</sup>					
96 hours	■				
160 hours		■	■		
2 x 160 hours (includes mid-BI test)				■	■
Final Electrical Test, MIL-PRF-38534, Group A, Subgroups 1 and 4: +25°C case	■				
Subgroups 1 through 6, -55°C, +25°C, +125°C case		■	■	■	■
Hermeticity Test					
Gross Leak, Method 1014	■	■	■	■	■
Fine Leak, Method 1014	■	■	■	■	■
Radiography, Method 2012				■	■
Post Radiography Electrical Test, +25°C case				■ <sup>4</sup>	■ <sup>4</sup>
Final visual inspection, Method 2009	■	■	■	■	■
RHA P: 30 kRad(Si) total dose <sup>6</sup>		■		■	
RHA R: 100 kRad(Si) total dose <sup>6</sup>			■		■
SEE LET 40 MeV-cm <sup>2</sup> /mg <sup>7</sup>		■	■	■	■

Test methods are referenced to MIL-STD-883 as determined by MIL-PRF-38534.

- Notes:
1. Redmond site, Interpoint brand, has a DSCC approved Radiation Hardness Assurance plan. Our SMD products with RHA "P" or "R" code met DSCC requirements.
  2. Space Prototypes are non-QML products and may not meet all of the requirements of MIL-PRF-38534. "O" in the RHA designator position in Interpoint model numbers indicates DSCC RHA "-" defined as no RHA.
  3. All processes are QML qualified and performed by certified operators.
  4. Not required by DSCC but performed to assure product quality.
  5. Burn-in temperature designed to bring the case temperature to +125°C minimum.
  6. Includes low dose rate to the rated total dose (TID)
  7. No upset at the pins.

SCREENING TABLE 2: ENVIRONMENTAL SCREENING AND RHA

SCREENING TABLE 2: ENVIRONMENTAL SCREENING AND RHA