

SPOC - BTS 5590GX

SPI Power Controller

for Advanced Light Control
with Integrated LED Mode and Watchdog

Automotive Power



Never stop thinking



Table of Contents	Page
Product Summary	5
1 Overview	8
1.1 Block Diagram	8
1.2 Terms	9
2 Pin Configuration	10
2.1 Pin Assignment SPOC - BTS 5590GX	10
2.2 Pin Definitions and Functions	10
3 Electrical Characteristics	12
3.1 Maximum Ratings	12
4 Block Description and Electrical Characteristics	14
4.1 Power Supply	14
4.1.1 Power Supply Modes	14
4.1.2 Reset	15
4.1.3 Electrical Characteristics	16
4.1.4 Command Description	18
4.2 Power Stages	19
4.2.1 Output ON-State Resistance	19
4.2.2 Input Circuit	19
4.2.3 Power Stage Output	20
4.2.4 Electrical Characteristics	22
4.2.5 Command Description	25
4.3 Protection Functions	27
4.3.1 Over Load Protection	27
4.3.2 Over Temperature Protection	28
4.3.3 Reverse Polarity Protection	28
4.3.4 Over Voltage Protection	29
4.3.5 Loss of Ground	29
4.3.6 Loss of V_{bb}	29
4.3.7 Electrical Characteristics	30
4.3.8 Command Description	32
4.4 Diagnosis	33
4.4.1 Diagnosis Word at SPI	34
4.4.2 Load Current Sense Diagnosis	35
4.4.3 Switch Bypass Diagnosis	38
4.4.4 Electrical Characteristics	39
4.4.5 Command Description	42
4.5 Limp Home	44
4.5.1 Watchdog	45

Table of Contents	Page
4.5.2 Trigger State Machine	46
4.5.3 Electrical Characteristics	47
4.5.4 Command Description	48
4.6 Serial Peripheral Interface (SPI)	50
4.6.1 SPI Signal Description	50
4.6.2 Daisy Chain Capability	51
4.6.3 Timing Diagrams	52
4.6.4 Electrical Characteristics	53
4.6.5 SPI Protocol	55
4.6.6 Register Overview	56
5 Application Description	57
6 Package Outlines SPOC - BTS 5590GX	58
7 Revision History	59

SPI Power Controller

SPOC - BTS 5590GX

for Advanced Light Control with Integrated LED Mode and Watchdog

The SPOC - BTS 5590GX is a five channel high-side smart power switch in P-DSO-36-20 package providing embedded protective functions. It is especially designed to control standard exterior lighting in automotive applications. In order to use the same hardware with bulbs and LEDs, the device can be configured to bulb or LED mode. As a result, both load types are handled optimized in switching and diagnosis accuracy.

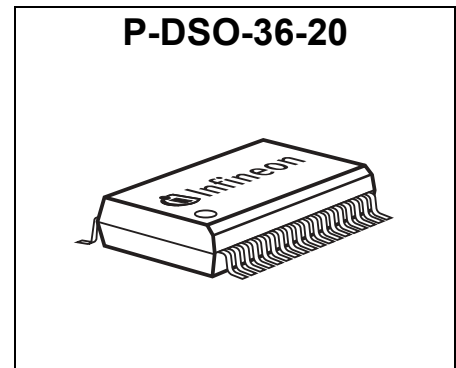

Configuration and status diagnosis is done via SPI. Additionally, there is a current sense signal available for each channel that is routed via a multiplexer to one diagnosis pin.

The SPOC - BTS 5590GX provides a fail-safe function with integrated watchdog. The watchdog is served via SPI by a sophisticated state machine providing secure limp home functionality.

Product Summary

Operating Voltage Power Switch	V_{bb}	4.5 ... 28 V
Logic Supply Voltage	V_{dd}	3.8 ... 5.5 V
Over Voltage Protection	$V_{bb(AZ,min)}$	41 V
Maximum Stand-By Current at 25 °C	$I_{bb(OFF)}$	3 μ A
On-State Resistance	$R_{DS(ON)}$	channel 0, 1 25 m Ω
		channel 2 40 m Ω
		channel 3, 4 100 m Ω
Nominal Loads (bulbs)	channel 0, 1, 2 channel 3, 4	27 W
		10 W
SPI Access Frequency	$f_{SCLK(max)}$	1 MHz

Type	Package	
SPOC - BTS 5590GX	P-DSO-36-20	

Basic Features

- 8 bit serial peripheral interface (daisy chain capable SPI) for control and diagnostics
- CMOS compatible parallel input pins for each channel provide straightforward PWM operation
- Selectable AND- / OR-combination for parallel inputs (PWM control)
- Very low stand-by current
- Optimized electromagnetic compatibility (EMC) for bulbs as well as LEDs
- Stable behavior at under voltage
- Device ground independent from load ground

Protective Functions

- Reverse battery protection with external components
- Short circuit protection
- Over load protection
- Multi step current limitation
- Thermal shutdown with latch
- Over voltage protection
- Loss of ground protection
- Electrostatic discharge protection (ESD)

Diagnostic Functions

- Multiplexed proportional load current sense signals (IS)
- Enable function for current sense signal configurable via SPI
- High accuracy of current sense signal at wide load current range
- Current sense ratio (k_{ILIS}) configurable for LEDs or bulbs
- Very fast diagnosis in LED mode (<2% duty cycle at 100 Hz)
- Feedback on over temperature and over load via SPI
- Multiplexed switch bypass monitor provides short circuit to V_{bb} detection

Application Specific Functions

- Integration of adjustable watchdog timer with external capacitor
- Sophisticated trigger state machine with two bit increment and lock, served via SPI
- Fail-safe configuration via input pins
- Load type configuration via SPI (bulbs or LEDs) for optimized load control

Applications

- High-side power switch for 12 V grounded loads in automotive application
- Especially designed for standard exterior lighting like tail light, stopping light, reverse light, parking light, license plate lighting, indicators and equivalent LEDs
- Replaces electromechanical relays, fuses and discrete circuits

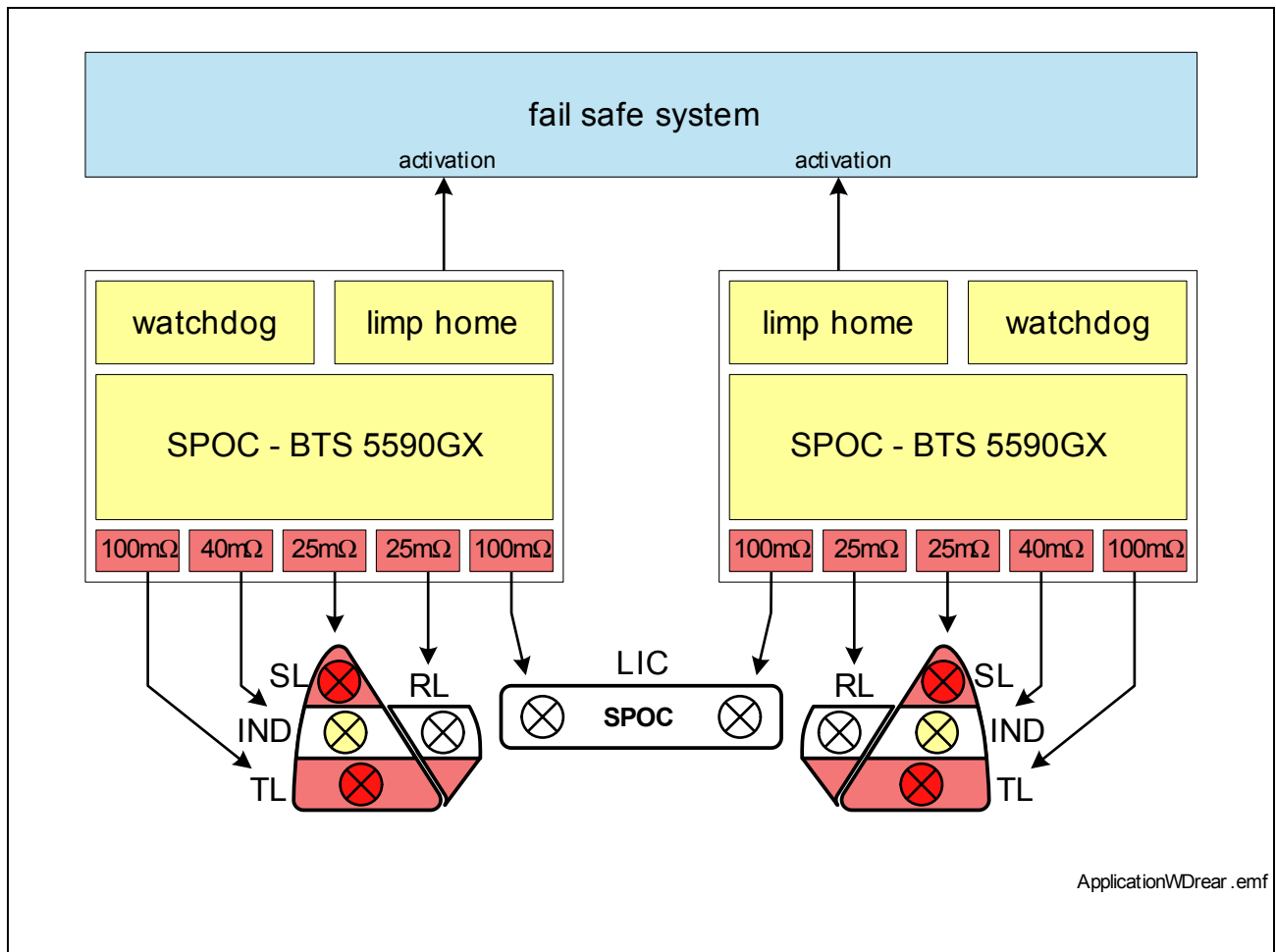

Figure 1 Application Example

Abbreviations:

- SL Stopping Light (21 W, 27 W)
- RL Reverse Light (21 W, 27 W)
- TL Tail Light (5 W, 7 W, 10 W)
- LIC License plate lighting (5 W, 10 W)
- IND Indicator / Flasher (21 W, 27 W)

1 Overview

The SPOC - BTS 5590GX is a five channel high-side power switch in P-DSO-36-20 package providing embedded protective functions. There is a watchdog integrated with two bit increment trigger. An 8 bit serial peripheral interface (SPI) is used for configuration and diagnosis. The SPI can be used in daisy chain configuration.

The sophisticated watchdog function provides secure limp home in combination with a limp home out signal. This signal can be individually connected to every input pin.

The device provides a current sense signal per channel that is multiplexed to the diagnosis pin IS. It can be enabled and disabled via SPI commands. An over load and over temperature flag is provided in the SPI diagnosis word. A multiplexed switch bypass monitor provides diagnosis at short-circuit to V_{bb} .

The power transistors are built by N-channel vertical power MOSFETs with charge pumps. The device is monolithically integrated in SMART SIPMOS technology.

1.1 Block Diagram

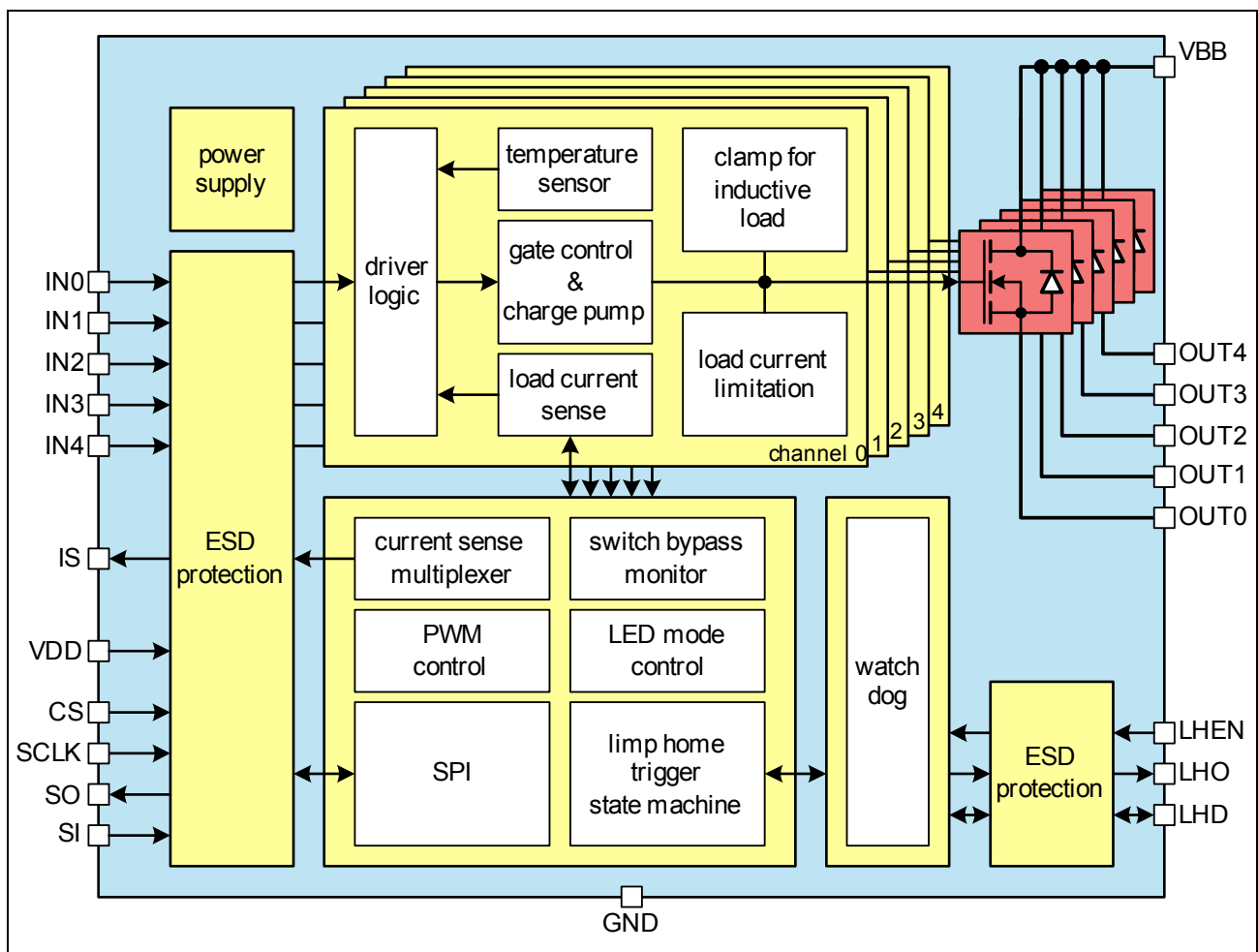
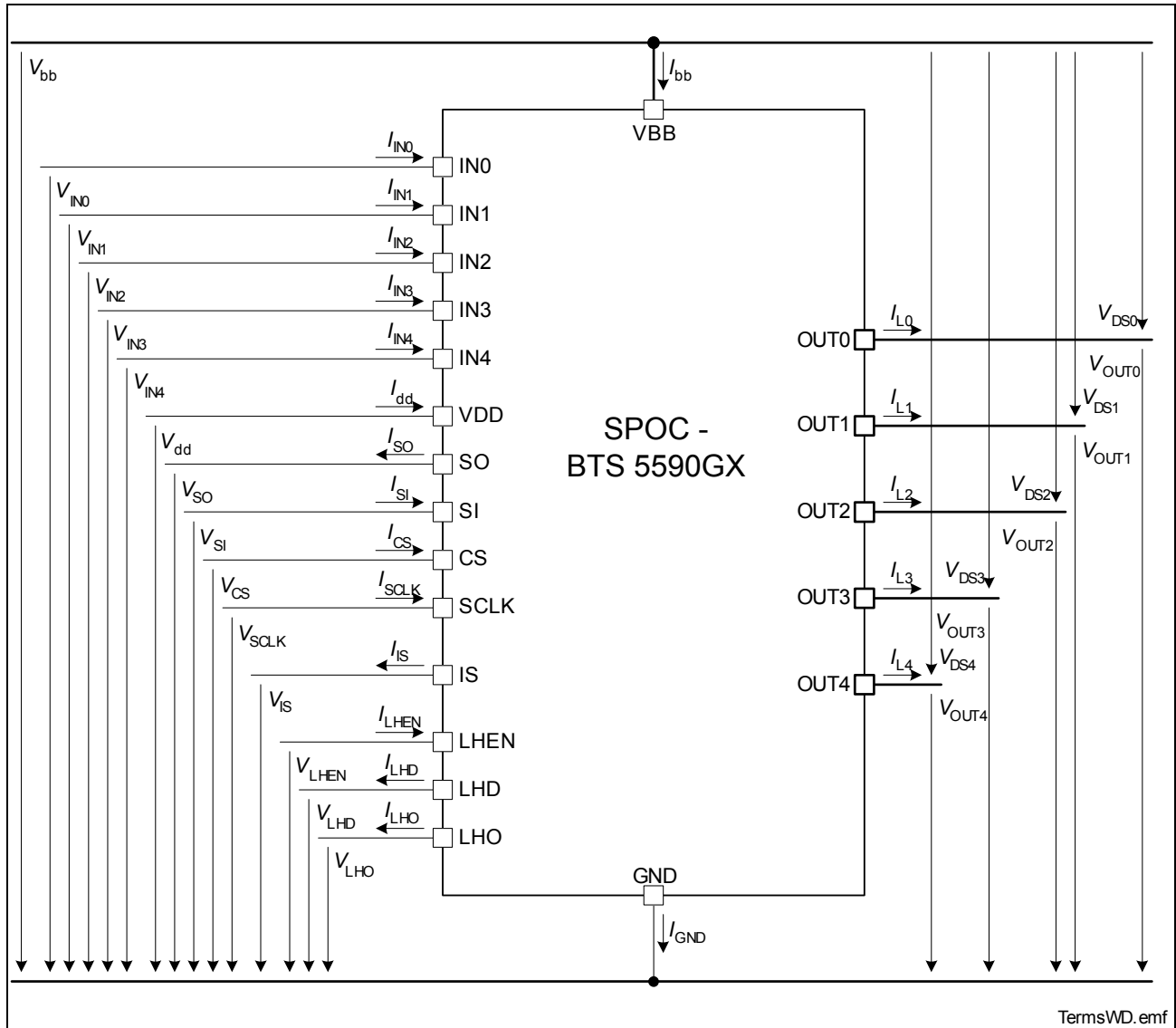

Figure 2 Block Diagram SPOC - BTS 5590GX

1.2 Terms

The following figure shows all terms used in this data sheet.



TermsWD.emf

Figure 3 Terms

In all tables of electrical characteristics is valid: Channel related symbols without channel number are valid for each channel separately (e.g. V_{DS} specification is valid for V_{DS0} ... V_{DS4}).

All SPI register bits are marked as follows: ADDR.PARAMETER (e.g. HWCR.CTL). In SPI register description, the values in bold letters (e.g. **0**) are default values.

2 Pin Configuration

2.1 Pin Assignment SPOC - BTS 5590GX

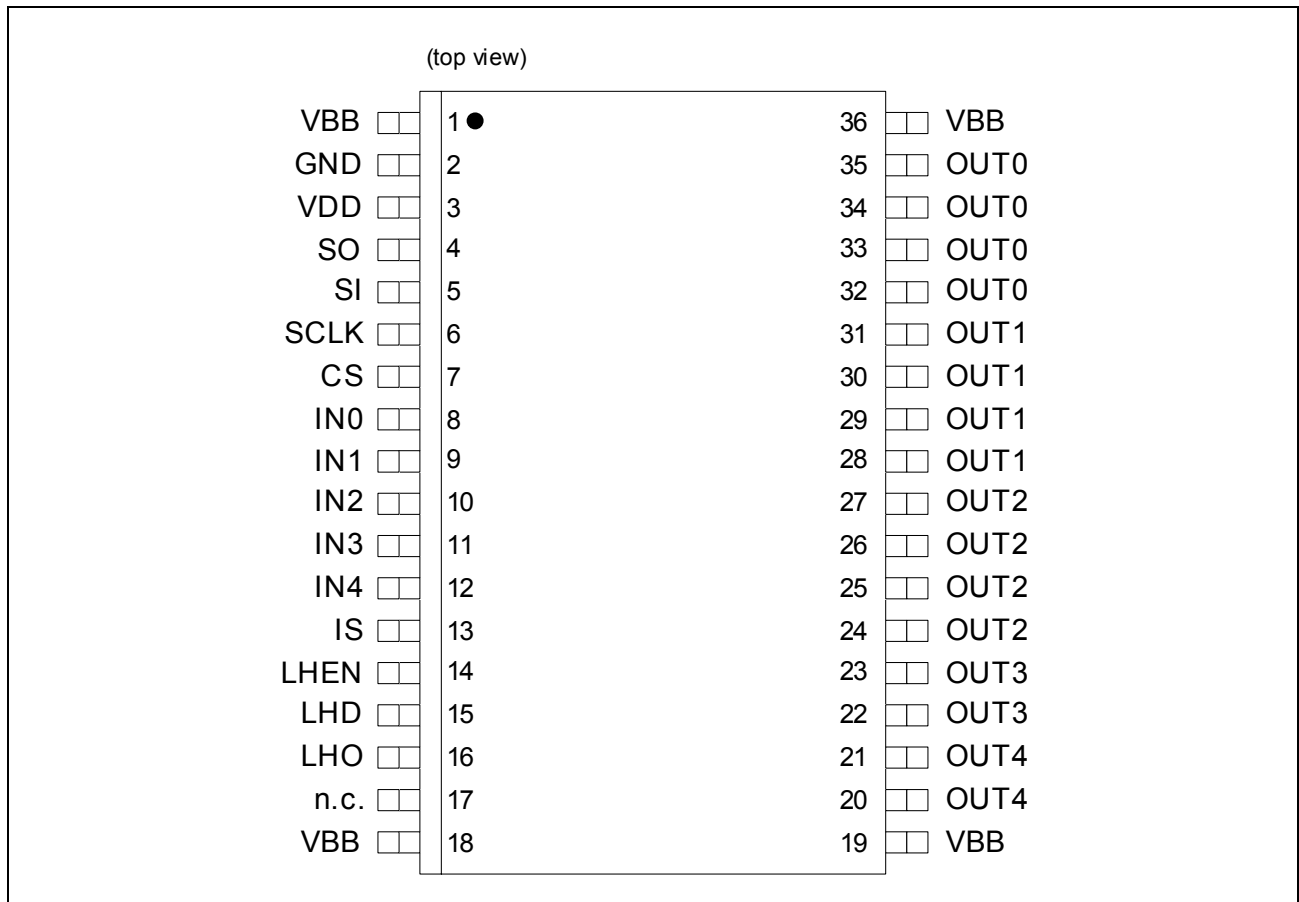

Figure 4 Pin Configuration P-DSO-36-20

2.2 Pin Definitions and Functions

Pin	Symbol	I/O	Function
Power Supply Pins			
1, 18, 19, 36 ¹⁾	VBB	–	Positive power supply for high-side power switch and limp home block
3	VDD	–	Logic supply (5 V)
2	GND	–	Ground connection
Parallel Input Pins			
8	IN0	I	Input signal of channel 0
9	IN1	I	Input signal of channel 1

Pin Configuration

Pin	Symbol	I/O	Function
10	IN2	I	Input signal of channel 2
11	IN3	I	Input signal of channel 3
12	IN4	I	Input signal of channel 4

Power Output Pins

32, 33, 34, 35 ²⁾	OUT0	O	Protected high-side power output of channel 0
28, 29, 30, 31 ²⁾	OUT1	O	Protected high-side power output of channel 1
24, 25, 26, 27 ²⁾	OUT2	O	Protected high-side power output of channel 2
22, 23 ²⁾	OUT3	O	Protected high-side power output of channel 3
20, 21 ²⁾	OUT4	O	Protected high-side power output of channel 4

SPI & Diagnosis Pins

7	CS	I	Chip select of SPI interface (low active)
6	SCLK	I	Serial clock of SPI interface
5	SI	I	Serial input of SPI interface
4	SO	O	Serial output of SPI interface
13	IS	O	Diagnosis output signal

Limp Home Pins

14	LHEN	I	WD and LH Enable signal
15	LHD	I/O	Connection for external time base of watchdog
16	LHO	O	Limp Home output

Other Pins

17	n.c.	–	not connected, floating
----	------	---	-------------------------

1) All VBB pins have to be connected.

2) All output pins of each channel have to be connected.

3 Electrical Characteristics

3.1 Maximum Ratings

Stresses above the ones listed here may affect device reliability or may cause permanent damage to the device.

Unless otherwise specified: $T_j = 25\text{ °C}$

Pos.	Parameter	Symbol	Limit Values		Unit	Conditions
			min.	max.		

Supply Voltage

3.1.1	Power supply voltage	V_{bb}	-0.3	28	V	
3.1.2	Logic supply voltage	V_{dd}	-0.3	5.5	V	
3.1.3	Reverse polarity voltage according Figure 26	$-V_{bat(rev)}$		16	V	$T_{jStart} = 25\text{ °C}$ $t \leq 2\text{ min}^1)$
3.1.4	Supply voltage for full short circuit protection (single pulse) ($T_{j(0)} = -40\text{ °C} \dots 150\text{ °C}$)	$V_{bb(SC)}$	0	20	V	$L_{SC} = 5\text{ }\mu\text{H}$, $R_{SC} = 0.1\text{ }\Omega$
3.1.5	Voltage at power transistor	V_{DS}		54	V	
3.1.6	Supply Voltage for Load Dump protection	$V_{bb(LD)}$		41	V	$R_l = 2\text{ }\Omega^2)$
3.1.7	Current through ground pin	I_{GND}	-100	25	mA	$t \leq 2\text{ min}$
3.1.8	Current through VDD pin	I_{dd}	-25	12	mA	$t \leq 2\text{ min}$

Power Stages

3.1.9	Load current	I_L	$-I_{L(LIM)}$	$I_{L(LIM)}$	A	³⁾
-------	--------------	-------	---------------	--------------	---	---------------

Diagnosis Pin

3.1.10	Current through sense pin IS	I_{IS}	-10	10	mA	$t \leq 2\text{ min}$
--------	------------------------------	----------	-----	----	----	-----------------------

Input Pins

3.1.11	Voltage at input pins	V_{IN}	-0.3	8.0	V	
3.1.12	Current through input pins	I_{IN}	0 -2.0	0.75 2.0	mA	$t \leq 2\text{ min}$

SPI Pins

3.1.13	Voltage at chip select pin	V_{CS}	-0.3	5.7	V	
3.1.14	Current through chip select pin	I_{CS}	-2.0	2.0	mA	$t \leq 2\text{ min}$
3.1.15	Voltage at serial input pin	V_{SI}	-0.3	5.7	V	

Electrical Characteristics

 Unless otherwise specified: $T_j = 25\text{ °C}$

Pos.	Parameter	Symbol	Limit Values		Unit	Conditions
			min.	max.		
3.1.16	Current through serial input pin	I_{SI}	-2.0	2.0	mA	$t \leq 2\text{ min}$
3.1.17	Voltage at serial clock pin	V_{SCLK}	-0.3	5.7	V	
3.1.18	Current through serial clock pin	I_{SCLK}	-2.0	2.0	mA	$t \leq 2\text{ min}$
3.1.19	Current through serial output pin SO	I_{SO}	-2.0	2.0	mA	$t \leq 2\text{ min}$

Limp Home Pins

3.1.20	Voltage at limp home enable pin	V_{LHEN}	-0.3	8.0	V	
3.1.21	Current through limp home enable pin	I_{LHEN}	0 -2.0	0.75 2.0	mA	$t \leq 2\text{ min}$
3.1.22	Current through limp home output pin	I_{LHO}	-2.0	2.0	mA	$t \leq 2\text{ min}$
3.1.23	Voltage at limp home delay pin	V_{LHD}	-0.3	5.7	V	
3.1.24	Current through limp home delay pin	I_{LHD}	-1.0	1.0	mA	$t \leq 2\text{ min}$

Temperatures

3.1.25	Junction temperature	T_j	-40	150	°C	
3.1.26	Dynamic temperature increase while switching	ΔT_j		60	°C	
3.1.27	Storage temperature	T_{stg}	-55	150	°C	

ESD Susceptibility

3.1.28	ESD susceptibility HBM	V_{ESD}			kV	according to EIA/JESD 22-A 114
	OUTpins		-4	4		
	other pins		-2	2		

- 1) Device mounted on PCB (40 mm × 40 mm × 1.5 mm epoxy, FR4) with maximum copper heatsinking area (two layer, 70 μm thick with vias) for V_{bb} connection. PCB is vertical without blown air.
- 2) R_i is the internal resistance of the load dump pulse generator.
- 3) Current limitation is a protection feature. Operation in current limitation is considered as “outside” normal operating range. Protection features are not designed for continuous repetitive operation.

4 Block Description and Electrical Characteristics

4.1 Power Supply

The SPOC - BTS 5590GX is supplied by two supply voltages V_{bb} and V_{dd} . The V_{bb} supply line is used by the power switches and by an internal power supply for the limp home function. The limp home power supply is enabled by pin LHEN. As a result, the stand-by current is minimized only when limp home function is disabled. The V_{dd} supply line is used by the SPI related circuitry and for driving the SO line. A capacitor between pins VDD and GND is recommended.

There is a power-on reset function implemented for the V_{dd} logic supply voltage. After start-up of the logic power supply, all SPI registers are reset to their default values. The SPI interface including daisy chain function is active as soon as V_{dd} is provided in the specified range independent of V_{bb} .

4.1.1 Power Supply Modes

The following table shows all possible power supply modes for V_{bb} , V_{dd} and the internal power supply that is enabled by pin LHEN.

Power Supply Modes

VBB	0 V	0 V	0 V	0 V	13.5 V	13.5 V	13.5 V	13.5 V
VDD	0 V	0 V	5 V	5 V	0 V	0 V	5 V	5 V
LHEN	0 V	5 V	0 V	5 V	0 V	5 V	0 V	5 V
PROFET operating	–	–	–	–	✓	✓	✓	✓
Watchdog active	–	–	–	–	–	✓ ¹⁾	–	✓ ¹⁾
SPI (logic)	reset	reset	✓	✓	reset	reset	✓	✓ ²⁾
Stand-by current					✓	–	–	–
Idle current					–	–	✓ ³⁾	–
Diagnosis					–	–	✓	✓ ⁴⁾

1) An active and unserved watchdog will cause limp home mode after overrun.

2) SPI reset in limp home mode.

3) When all channels are in OFF-state and all SPI registers are at default values.

4) Current sense diagnosis not available in limp home mode.

To achieve stand-by mode, the limp home block must be disabled (LHEN = 0 V), all channels must be switched off and the thermal latches have to be cleared. As a result the stand-by current $I_{bb(OFF)}$ is valid as listed. In case of active V_{dd} supply, the idle mode

parameters are valid only, when additionally all SPI registers are at default values (see [Section 4.6.6](#)) e.g. after a reset command.

4.1.2 Reset

There are several reset trigger implemented in the device. They reset the SPI registers to their default values. The power stages as well as the analog watchdog block are not affected by the reset signals.

The first SPI transmission after any kind of reset contains at pin SO the read information from register `OUT`, and the transmission error bit `TER` is set.

Power-On Reset. The power-on reset is released, when V_{dd} voltage level is higher than $V_{dd(PO)}$. The SPI interface can be accessed after wake up time $t_{WU(PO)}$.

Reset Command. There is a reset command available to reset all register bits of the register bank and the diagnosis registers. As soon as `HWCR.RST = 1`, a reset is triggered equivalent to power-on reset. The SPI interface can be accessed after transfer delay time $t_{SC(td)}$.

Limp Home Mode. In limp home mode, the SPI write-registers are reset. The SPI interface is operating normally, so the limp home register bits `LHO` and `LHEN` as well as the error flags can be read.

4.1.3 Electrical Characteristics

Unless otherwise specified: $V_{bb} = 9\text{ V to }16\text{ V}$, $V_{dd} = 3.8\text{ V to }5.5\text{ V}$, $T_j = -40\text{ °C to }+150\text{ °C}$
 typical values: $V_{bb} = 13.5\text{ V}$, $V_{dd} = 4.3\text{ V}$, $T_j = 25\text{ °C}$

Pos.	Parameter	Symbol	Limit Values			Unit	Test Conditions
			min.	typ.	max.		
4.1.1	Operating voltage power switch	V_{bb}	4.5		28	V	
4.1.2	Operating voltage watchdog	$V_{bb(WD)}$	9		28 ¹⁾	V	
4.1.3	Stand-by current for whole device with loads	$I_{bb(OFF)}$		1.2	3 3 50	μA	$V_{dd} = 0\text{ V}$ $V_{LHEN} = 0\text{ V}$ $V_{IN} = 0\text{ V}$ $T_j = 25\text{ °C}$ $T_j \leq 85\text{ °C }^1)$ $T_j = 150\text{ °C}$
	Idle current for whole device with loads	$I_{bb(idle)}$			3 3 50	μA	$V_{dd} = 5\text{ V}$ $V_{LHEN} = 0\text{ V}$ $V_{IN} = 0\text{ V}$ $T_j = 25\text{ °C}$ $T_j \leq 85\text{ °C }^1)$ $T_j = 150\text{ °C}$
4.1.4	Logic supply voltage	V_{dd}	3.8		5.5	V	
4.1.5	Logic supply current	I_{dd}		45	150	μA	$V_{CS} = 0\text{ V}$ $f_{SCLK} = 0\text{ Hz}$
4.1.6	Logic idle current	$I_{dd(idle)}$		15	35	μA	$V_{CS} = V_{dd}$ $f_{SCLK} = 0\text{ Hz}$
4.1.7	Operating current for whole device	I_{GND}		10	20	mA	$f_{SCLK} = 0\text{ Hz}$

Unless otherwise specified: $V_{bb} = 9\text{ V to }16\text{ V}$, $V_{dd} = 3.8\text{ V to }5.5\text{ V}$, $T_j = -40\text{ °C to }+150\text{ °C}$
 typical values: $V_{bb} = 13.5\text{ V}$, $V_{dd} = 4.3\text{ V}$, $T_j = 25\text{ °C}$

Pos.	Parameter	Symbol	Limit Values			Unit	Test Conditions
			min.	typ.	max.		
Reset							
4.1.8	Power-On reset threshold voltage	$V_{dd(PO)}$			3.8	V	
4.1.9	Power-On wake up time	$t_{WU(PO)}$			500	μs	

1) Not subject to production test, specified by design.

Note: Characteristics show the deviation of parameter at the given supply voltage and junction temperature. Typical values show the typical parameters expected from manufacturing at $V_{bb} = 13.5\text{ V}$, $V_{dd} = 4.3\text{ V}$ and $T_j = 25\text{ °C}$

4.1.4 Command Description

HWCR

Hardware Configuration Register

W/R	4	3	2	1	0
read	LHO	WDL	SBM	PWM	CTL
write	RST	WDL	0	PWM	CTL

Field	Bits	Type	Description
RST	4	r	Reset Command 0 Normal operation 1 Device in reset due to limp home mode
		w	Reset Command 0 Normal operation 1 Execute reset command

4.2 Power Stages

The high-side power stages are built by N-channel vertical power MOSFETs (DMOS) with charge pumps. There are five channels implemented in the device. Each channel can be switched on via an input pin or via SPI register `OUT`. Channels 0, 1 and 2 provide a load type configuration for bulbs or LEDs in register `WDLR`. The load type configuration is allowed to be changed in OFF-state only.

4.2.1 Output ON-State Resistance

The on-state resistance $R_{DS(ON)}$ depends on the supply voltage V_{bb} as well as on the junction temperature T_j . **Figure 5** shows those dependencies. The behavior in reverse polarity mode is described in **Section 4.3.3**.

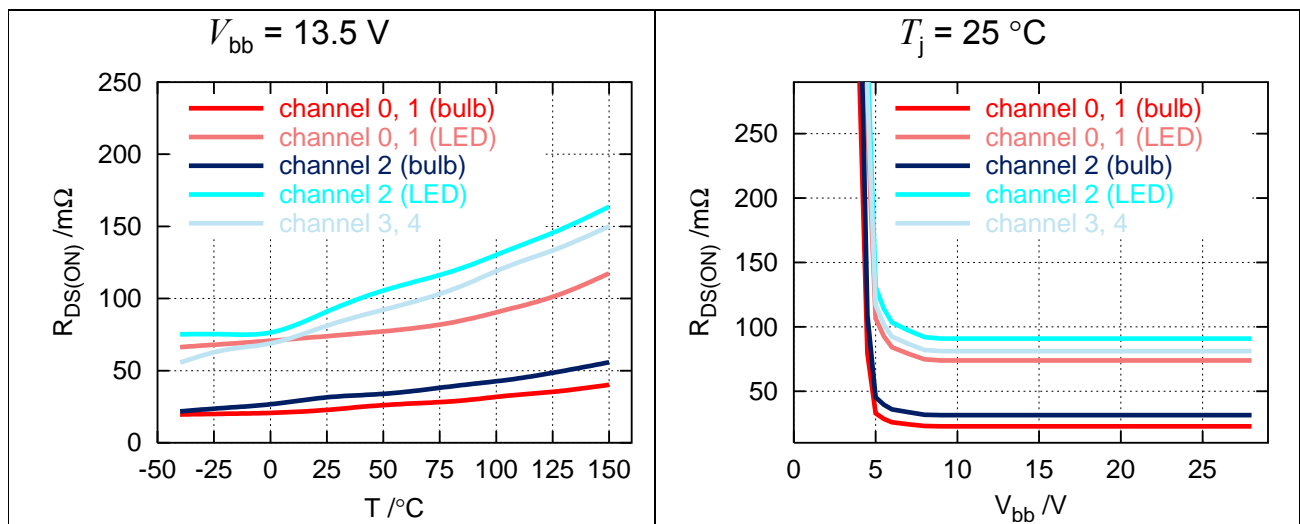

Figure 5 Typical On-State Resistance

4.2.2 Input Circuit

There are two ways of using the input pins in combination with the `OUT` register by programming the `HWCR.PWM` parameter.

- `HWCR.PWM = 0`: A channel is switched on either by the according `OUT` register bit or the input pin
- `HWCR.PWM = 1`: A channel is switched on by the according `OUT` register bit only, when the input pin is high. In this configuration, a PWM signal can be given to the input pin and the channel is activated by the SPI register `OUT`

Figure 6 shows the complete input switch matrix.

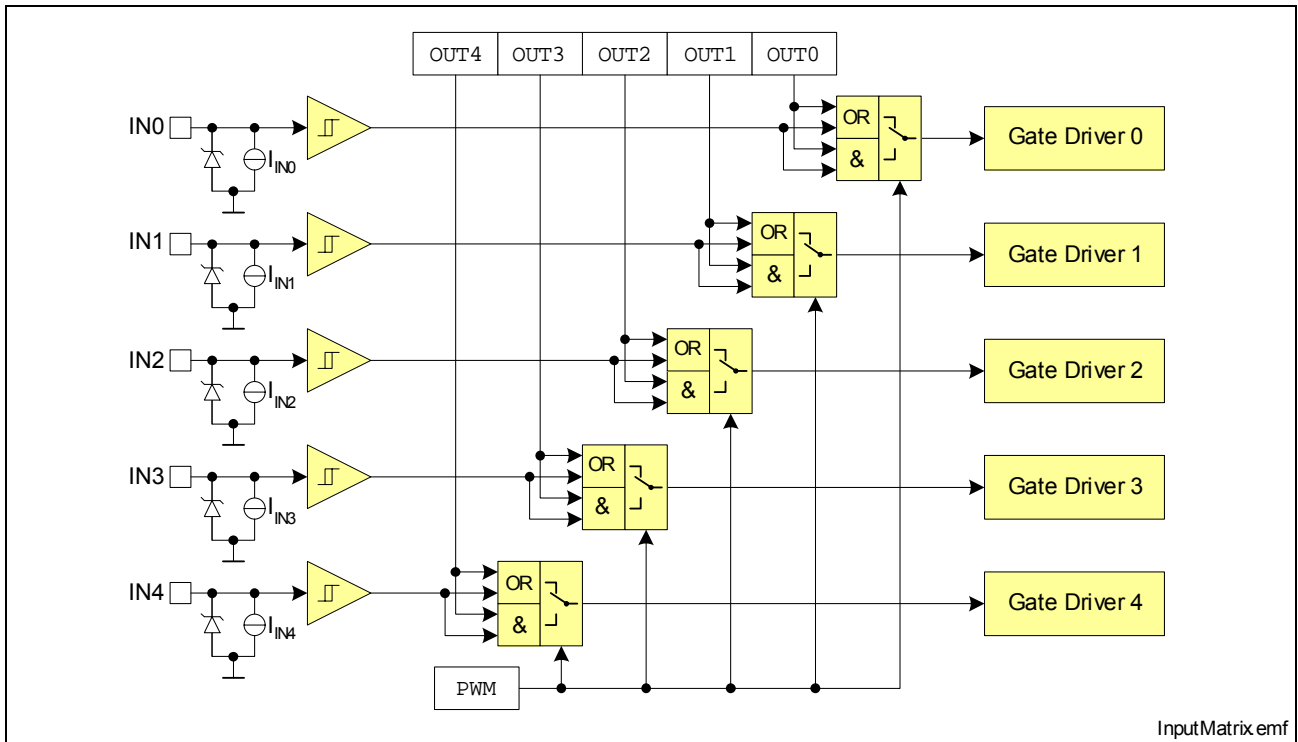

Figure 6 Input Switch Matrix

The current sink to ground at the input pins ensures that the input signal is low in case of an open input pin. The zener diode protects the input circuit against ESD pulses.

4.2.3 Power Stage Output

The power stages are built to be used in high side configuration ([Figure 7](#)).

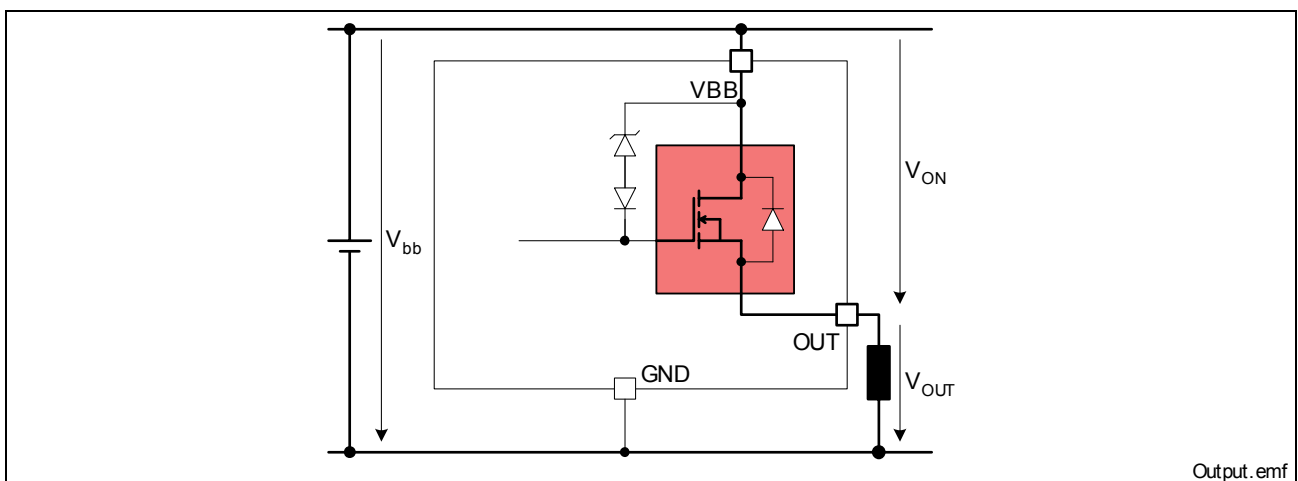

Figure 7 Power Stage Output

The power DMOS switches with a dedicated slope, which is optimized in terms of EMC emission.

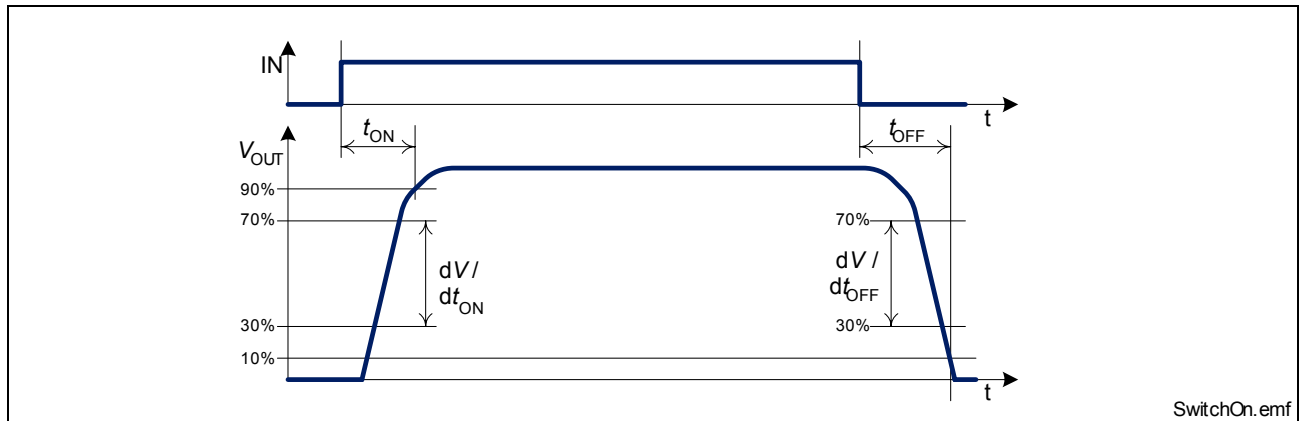

Figure 8 Switching a Load (resistive)

When switching off inductive loads with high-side switches, the voltage V_{OUT} drops below ground potential, because the inductance intends to continue driving the current. To prevent destruction of the device, there is a voltage clamp mechanism implemented that limits that negative output voltage to a certain level ($V_{ON(CL)}$ (4.2.3)). See [Figure 7](#) for details. The maximum allowed load inductance is limited.

4.2.4 Electrical Characteristics

Unless otherwise specified: $V_{bb} = 9\text{ V to }16\text{ V}$, $T_j = -40\text{ °C to }+150\text{ °C}$
 typical values: $V_{bb} = 13.5\text{ V}$, $T_j = 25\text{ °C}$

Pos.	Parameter	Symbol	Limit Values			Unit	Test Conditions
			min.	typ.	max.		
Output Characteristics							
4.2.1	On-State resistance channel 0, 1	$R_{DS(ON)}$		22.8	50	mΩ	WDLR.LEDn = 0 $I_L = 2.6\text{ A}$
				74	150		WDLR.LEDn = 1 $I_L = 700\text{ mA}$
	channel 2		31.5	80	mΩ	WDLR.LEDn = 0 $I_L = 2.6\text{ A}$	
			91	240		WDLR.LEDn = 1 $I_L = 700\text{ mA}$	
	channel 3, 4		81	200		$I_L = 1\text{ A}$	
4.2.2	Output voltage drop limitation at small load currents	$V_{DS(NL)}$		35		mV	$I_L = 35\text{ mA}$
				35			$I_L = 35\text{ mA}$
4.2.3	Output clamp	$V_{ON(CL)}$	41	47	54	V	$I_L = 20\text{ mA}$
4.2.4	Output leakage current per channel	$I_{L(OFF)}$		0.1	10	μA	$V_{IN} = 0\text{ V}$ OUT.OUTn = 0
					40		$V_{LHEN} = 0\text{ V}$
				0.1	10		$V_{LHEN} = 5\text{ V}$
					40		$V_{LHEN} = 0\text{ V}$
	channel 3, 4		0.1	8	$V_{LHEN} = 5\text{ V}$		
				40	$V_{LHEN} = 0\text{ V}$ $V_{LHEN} = 5\text{ V}$		
4.2.5	Inverse current capability per channel	$-I_{L(IC)}$		2.5		A	No influence on functionality of unaffected channels ¹⁾
				1.0			

Unless otherwise specified: $V_{bb} = 9\text{ V to }16\text{ V}$, $T_j = -40\text{ °C to }+150\text{ °C}$
 typical values: $V_{bb} = 13.5\text{ V}$, $T_j = 25\text{ °C}$

Pos.	Parameter	Symbol	Limit Values			Unit	Test Conditions
			min.	typ.	max.		

Thermal Resistance

4.2.6	Junction to case	R_{thjc}			20	K/W	1)
4.2.7	Junction to ambient, all channels active	R_{thja}		40		K/W	1) 2)

Input Characteristics

4.2.8	L-input level	$V_{IN(L)}$	-0.3		1.0	V	
4.2.9	H-input level	$V_{IN(H)}$	2.6		5.5	V	
4.2.10	L-input current	$I_{IN(L)}$	3	25	75	μA	$V_{IN} = 0.4\text{ V}$
4.2.11	H-input current	$I_{IN(H)}$	10	40	75	μA	$V_{IN} = 5\text{ V}$

Timings

4.2.12	Turn-on time to 90% V_{bb} channel 0, 1, 2	t_{ON}			250 100	μs	$V_{bb} = 13.5\text{ V}$ WDLR.LEDn = 0 $R_L = 6.8\ \Omega$ WDLR.LEDn = 1 $R_L = 33\ \Omega$			
	channel 3, 4							250 $R_L = 18\ \Omega$		
4.2.13	Turn-off time to 10% V_{bb} channel 0, 1, 2	t_{OFF}			290 120	μs	$V_{bb} = 13.5\text{ V}$ WDLR.LEDn = 0 $R_L = 6.8\ \Omega$ WDLR.LEDn = 1 $R_L = 33\ \Omega$			
	channel 3, 4							290 $R_L = 18\ \Omega$		
4.2.14	Turn-on slew rate 30% to 70% V_{bb} channel 0, 1, 2	dV/dt_{ON}			0.1 0.5	V/ μs	$V_{bb} = 13.5\text{ V}$ WDLR.LEDn = 0 $R_L = 6.8\ \Omega$ WDLR.LEDn = 1 $R_L = 33\ \Omega$			
								channel 3, 4	0.1 1.5	$R_L = 18\ \Omega$
									0.1 0.5	

Unless otherwise specified: $V_{bb} = 9\text{ V to }16\text{ V}$, $T_j = -40\text{ °C to }+150\text{ °C}$
 typical values: $V_{bb} = 13.5\text{ V}$, $T_j = 25\text{ °C}$

Pos.	Parameter	Symbol	Limit Values			Unit	Test Conditions
			min.	typ.	max.		
4.2.15	Turn-off slew rate 70% to 30% V_{bb} channel 0, 1, 2	$-dV/dt_{OFF}$	0.1		0.5	V/ μ s	$V_{bb} = 13.5\text{ V}$ WDLR.LEDn = 0 $R_L = 6.8\ \Omega$
	0.1			1.5	WDLR.LEDn = 1 $R_L = 33\ \Omega$		
	0.1			0.5	$R_L = 18\ \Omega$		

- 1) Not subject to production test, specified by design.
- 2) Device mounted on PCB (40 mm \times 40 mm \times 1.5 mm epoxy, FR4) with maximum copper heatsinking area (two layer, 70 μ m thick with vias) for V_{bb} connection. PCB is vertical without blown air.

4.2.5 Command Description

OUT Output Configuration Registers

4	3	2	1	0
OUT4	OUT3	OUT2	OUT1	OUT0

Field	Bits	Type	Description
OUTn n = 4 to 0	n	rw	Set Output Mode for Channel n 0 Channel n is switched off 1 Channel n is switched on

WDLR Watchdog and LED Mode Configuration Register

$\overline{W/R}$	4	3	2	1	0
read	WDC		LED2	LED1	LED0
write	WDTR		LED2	LED1	LED0

Field	Bits	Type	Description
LEDn n = 2 to 0	n	rw	Set LED Mode for Channel n 0 Channel n is in bulb mode 1 Channel n is in LED mode

HWCR
Hardware Configuration Register

W/\bar{R}	4	3	2	1	0
read	LHO	WDL	SBM	PWM	CTL
write	RST	WDL	0	PWM	CTL

Field	Bits	Type	Description
PWM	1	rw	PWM Configuration 0 Input signal OR-combined with according OUT register bit 1 Input signal AND-combined with according OUT register bit

4.3 Protection Functions

The device provides embedded protective functions, which are designed to prevent IC destruction under fault conditions described in this data sheet. Fault conditions are considered as “outside” normal operating range. Protective functions are neither designed for continuous nor for repetitive operation.

4.3.1 Over Load Protection

The load current I_L is limited by the device itself in case of over load or short circuit to ground. There are multiple steps of current limitation which are selected automatically depending on the voltage V_{DS} across the power DMOS. Please note that the voltage at the OUT pin is $V_{bb} - V_{DS}$. Please refer to following figures for details.

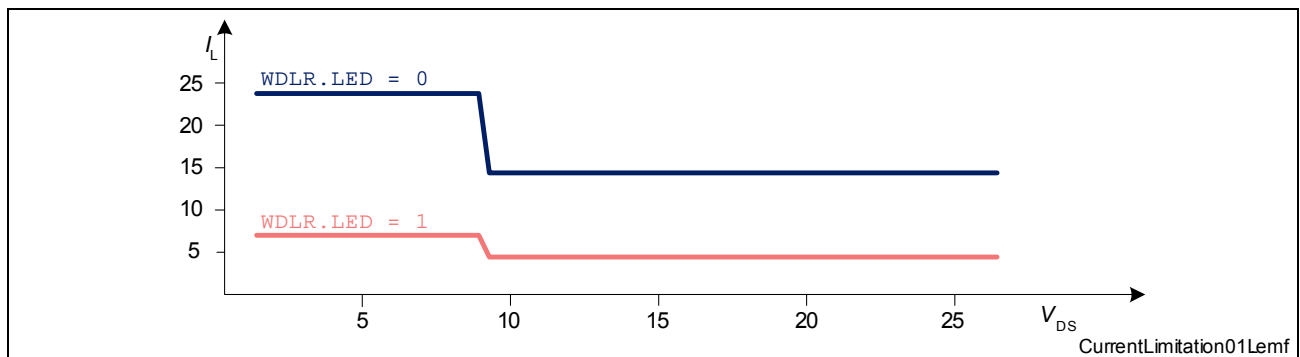

Figure 9 Current Limitation Channels 0, 1 (minimum values)

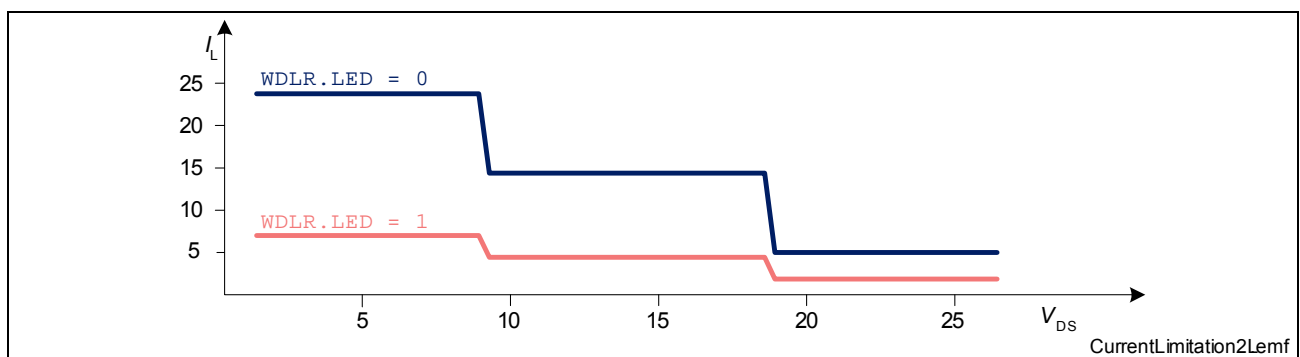

Figure 10 Current Limitation Channels 2 (minimum values)

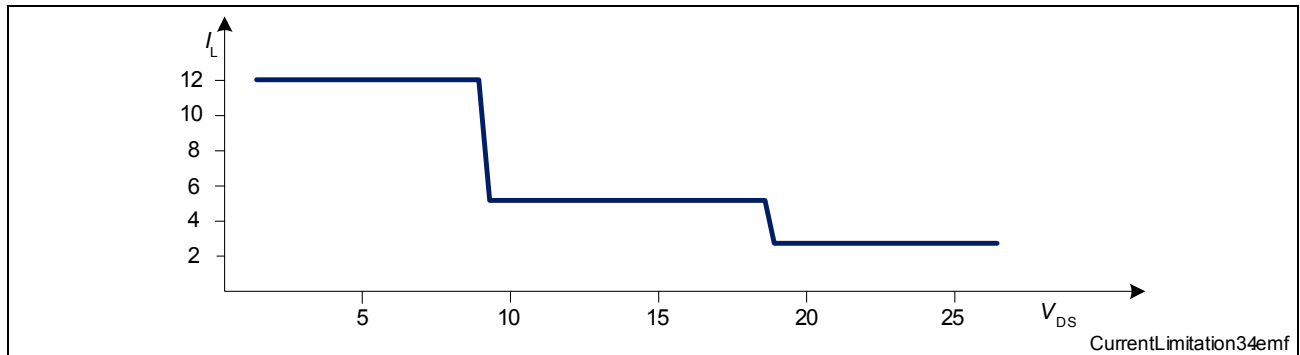

Figure 11 Current Limitation Channels 3, 4 (minimum values)

Current limitation to the value $I_{L(LIM)}$ is realized by increasing the resistance of the output channel, which leads to rapid temperature rise inside.

4.3.2 Over Temperature Protection

A temperature sensor for each channel causes an overheated channel to switch off latched to prevent destruction. All over temperature latches are cleared by SPI command $HWCR.CTL = 1$.

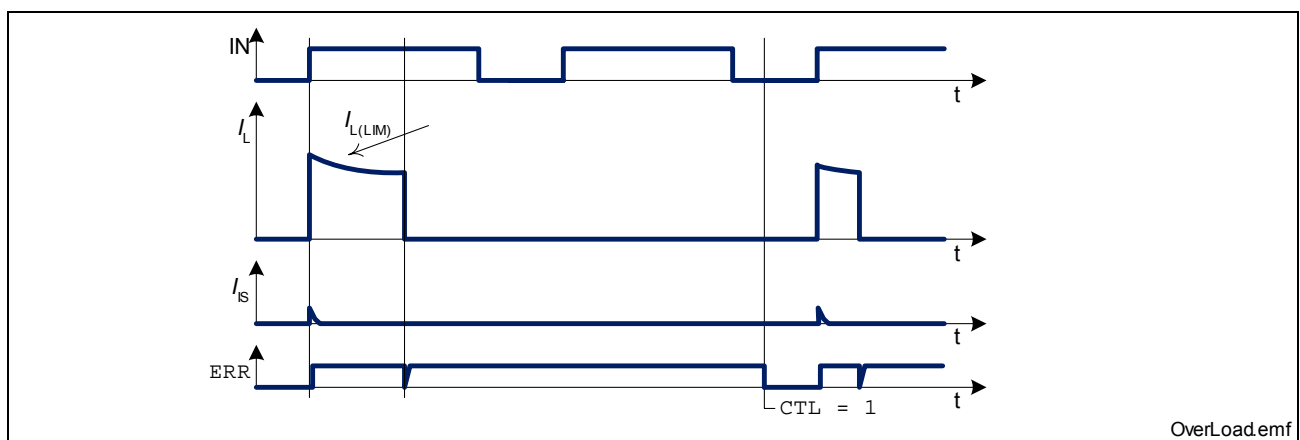

Figure 12 Shut Down by Over Temperature

4.3.3 Reverse Polarity Protection

In reverse polarity mode, power dissipation is caused by the intrinsic body diode of each DMOS channel as well as each ESD diode of the logic pins. The reverse current through the channels has to be limited by the connected loads. The current through the ground pin, sense pin IS , the logic power supply pin VDD , the SPI pins and the watchdog pins has to be limited as well (please refer to the maximum ratings listed on [Page 12](#)).

Note: No other protection mechanism like temperature protection or current limitation is active during reverse polarity.

4.3.4 Over Voltage Protection

In addition to the output clamp for inductive loads as described in [Section 4.2.3](#), there is a clamp mechanism available for over voltage protection. The current through the ground connection has to be limited during over voltage. Please note that in case of over voltage the pin GND might have a high voltage offset to the module ground.

4.3.5 Loss of Ground

In case of complete loss of the device ground connections, but connected load ground, the SPOC - BTS 5590GX securely changes to or stays in off-state.

4.3.6 Loss of V_{bb}

In case of loss of V_{bb} connection in on-state, all inductance of the loads has to be demagnetized through the ground connection or through an additional path from VBB to ground. When a diode is used in the ground path for reverse polarity reason, the ground connection is not available for demagnetization. Then for example, a resistor can be placed in parallel to the diode or a suppressor diode can be used between VBB and GND.

4.3.7 Electrical Characteristics

Unless otherwise specified: $V_{bb} = 9\text{ V to }16\text{ V}$, $T_j = -40\text{ °C to }+150\text{ °C}$
 typical values: $V_{bb} = 13.5\text{ V}$, $T_j = 25\text{ °C}$

Pos.	Parameter	Symbol	Limit Values			Unit	Test Conditions
			min.	typ.	max.		

Over Load Protection

4.3.1	Load current limitation	$I_{L(LIM)}$				A	$V_{DS} = 7\text{ V}$ WDLR.LEDn = 0 WDLR.LEDn = 1
	channel 0, 1		24 7		48 ¹⁾ 18		
	channel 2		24 7		48 ¹⁾ 18		
	channel 3, 4		12		27		
4.3.2	Initial short circuit shut down time	$t_{OFF(SC)}$				μS	$T_{jStart} = 25\text{ °C }^1)$ WDLR.LEDn = 0 WDLR.LEDn = 1
	channel 0, 1				550 500		
	channel 2				400 350		
	channel 3, 4				400		

Over Temperature Protection

4.3.3	Thermal shut down temperature	$T_{j(SC)}$	150	170 ¹⁾		°C	
4.3.4	Thermal hysteresis	ΔT_j		7		K	1)

Reverse Battery

4.3.5	Drain-Source diode voltage ($V_{OUT} > V_{bb}$)	$-V_{DS(rev)}$				mV	$T_j = 150\text{ °C}$ $I_L = -2.5\text{ A}$ $I_L = -2.5\text{ A}$ $I_L = -1\text{ A}$
	channel 0, 1				600		
	channel 2				620		
	channel 3, 4				600		

Over Voltage

4.3.6	Overvoltage protection	$V_{bb(AZ)}$	41	47	54	V	$I_{bb} = 4\text{ mA}$
-------	------------------------	--------------	----	----	----	---	------------------------

Protection Functions

Unless otherwise specified: $V_{bb} = 9\text{ V to }16\text{ V}$, $T_j = -40\text{ °C to }+150\text{ °C}$
 typical values: $V_{bb} = 13.5\text{ V}$, $T_j = 25\text{ °C}$

Pos.	Parameter	Symbol	Limit Values			Unit	Test Conditions
			min.	typ.	max.		
Loss of GND protection							
4.3.7	Output current while GND disconnected	$I_{L(GND)}$			1	mA	¹⁾

1) Not subject to production test, specified by design.

4.3.8 Command Description

HWCR

Hardware Configuration Register

W/R	4	3	2	1	0
read	LHO	WDL	SBM	PWM	CTL
write	RST	WDL	0	PWM	CTL

Field	Bits	Type	Description
CTL	0	rw	Clear Thermal Latch 0 Thermal latches are untouched 1 Command: Clear all thermal latches

4.4 Diagnosis

For diagnosis purpose, the SPOC - BTS 5590GX provides a current sense signal and the diagnosis word at SPI. There is a current sense multiplexer implemented that is controlled via SPI. The sense signal can also be disabled by SPI command. A switch bypass monitor allows to detect a short circuit between the output pin and the battery voltage.

Please refer to **Figure 13** for details.

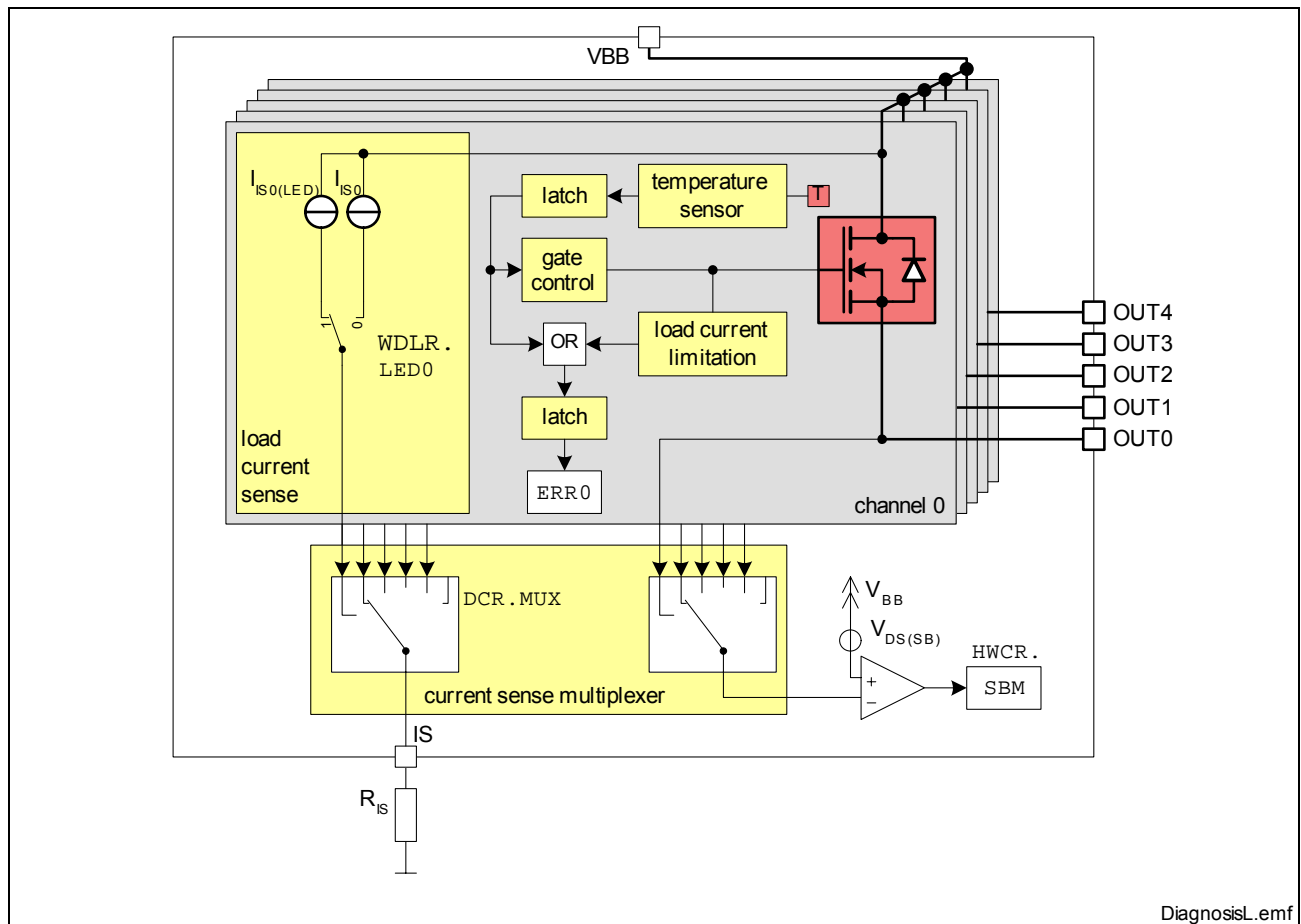

Figure 13 Block Diagram: Diagnosis

For diagnosis feedback at different operation modes, please see following table.

Table 1 Operation Modes ¹⁾

Operation Mode	Input Level OUT. OUTn	Output Level V_{OUT}	Current Sense I_{IS}	Error Flag ERRn ²⁾	HWCR. SBM
Normal Operation (OFF)	L / 0 (OFF-state)	GND	Z	0	1
Short Circuit to GND		GND	Z	0	1
Over Temperature		Z	Z	0	x
Short Circuit to V_{bb}		V_{bb}	Z	0	0
Open Load		Z	Z	0	x
Normal Operation (ON)	H / 1 (ON-state)	$\sim V_{bb}$	I_L / k_{ILIS}	0	0
Current Limitation		$< V_{bb}$	Z	1	x
Short Circuit to GND		\sim GND	Z	1	1
Over Temperature		Z	Z	1 ³⁾	x
Short Circuit to V_{bb}		V_{bb}	$< I_L / k_{ILIS}$	0	0
Open Load		V_{bb}	Z	0	0

1) L = low level, H = high level, Z = high impedance, potential depends on leakage currents and external circuit
x = undefined

2) The error flags are latched until they are transmitted in the standard diagnosis word via SPI

3) The over temperature flag is set latched and can be cleared by SPI command HWCR.CTL

4.4.1 Diagnosis Word at SPI

The standard diagnosis at the SPI interface provides information about each channel. The error flags, an OR combination of the over temperature flags and the over load monitoring signals are provided in the SPI standard diagnosis bits ERRn.

The over load monitoring signals are latched in the error flags and cleared each time the standard diagnosis is transmitted via SPI. In detail, they are cleared between the second and third raising edge of the SCLK signal.

The over temperature flags, which cause an overheated channel to stay switched off, are latched directly at the gate control block. The latches are cleared by SPI command HWCR.CTL.

Please note: The over temperature information is latched twice. When transmitting a clear thermal latch command (HWCR.CLT), the error flag is cleared during command transmission of the next SPI frame and ready for latching after the third raising edge of the SCLK signal. As a result, the first standard diagnosis information after a CTL command will indicate a failure mode at the previously affected channels although the

thermal latches have been cleared already. In case of continuous over load, the error flags are set again immediately because of the over load monitoring signal.

4.4.2 Load Current Sense Diagnosis

There is a current sense signal available at pin IS which provides a current proportional to the load current of one selected channel. The selection is done by a multiplexer which is configured via SPI.

Current Sense Signal

The current sense signal (ratio $k_{ILIS} = I_L / I_S$) is provided as long as no failure mode occurs. The ratio k_{ILIS} can be adjusted to the load type (LED or bulb) via SPI register WDLR for channels 0 to 2. Usually a resistor R_{IS} is connected to the current sense pin. It is recommended to use resistors $2.5 \text{ k}\Omega < R_{IS} < 7 \text{ k}\Omega$. A typical value is $3.3 \text{ k}\Omega$.

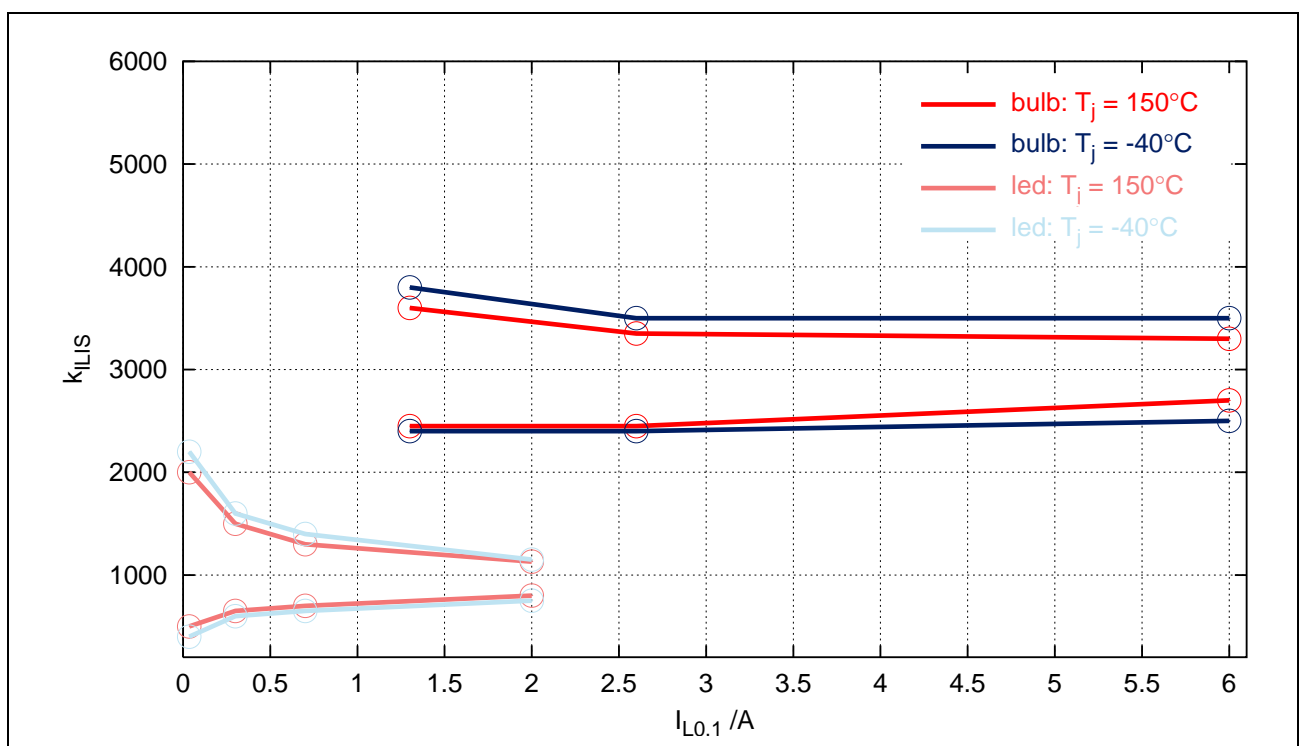

Figure 14 Current Sense Ratio k_{ILIS} Channel 0,1 ¹⁾

1) The curves show the behavior based on characterization data. The marked points are guaranteed in this Data Sheet in [Section 4.4.4](#) (Position [4.4.1](#)).

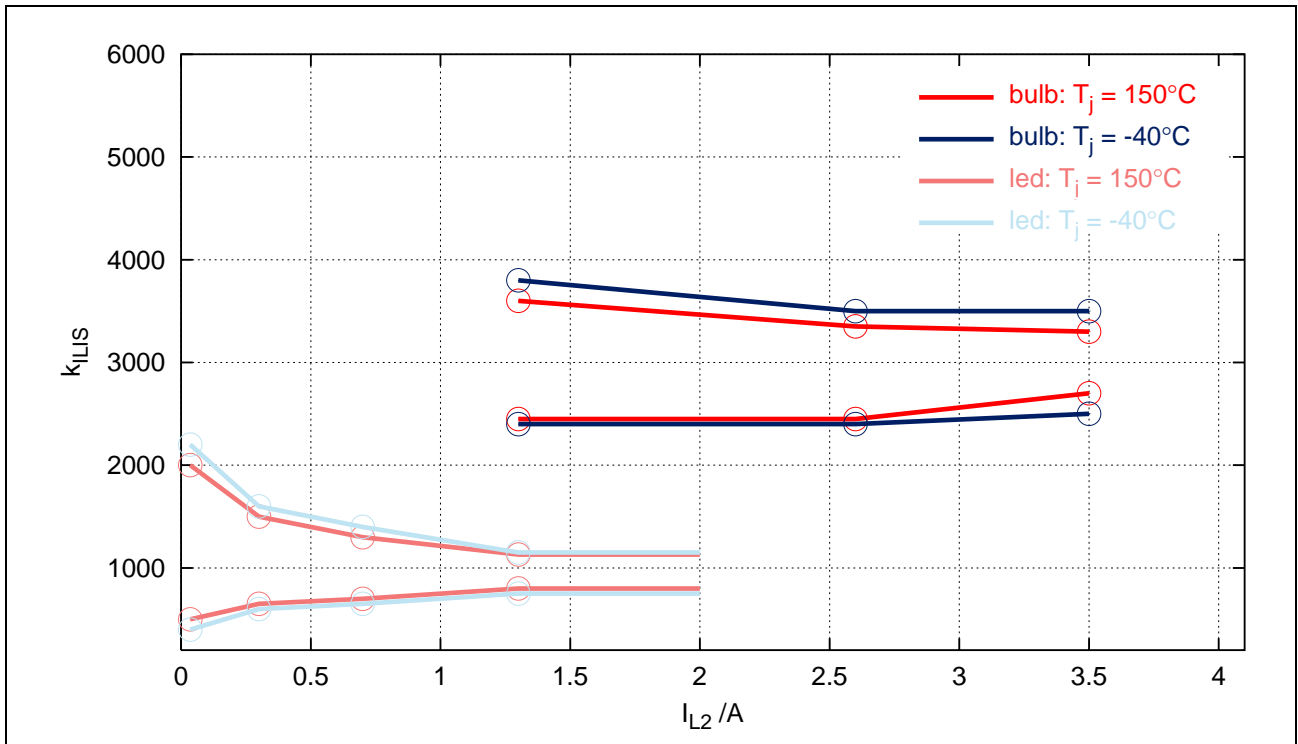

Figure 15 Current Sense Ratio k_{ILIS} Channel 2 ¹⁾

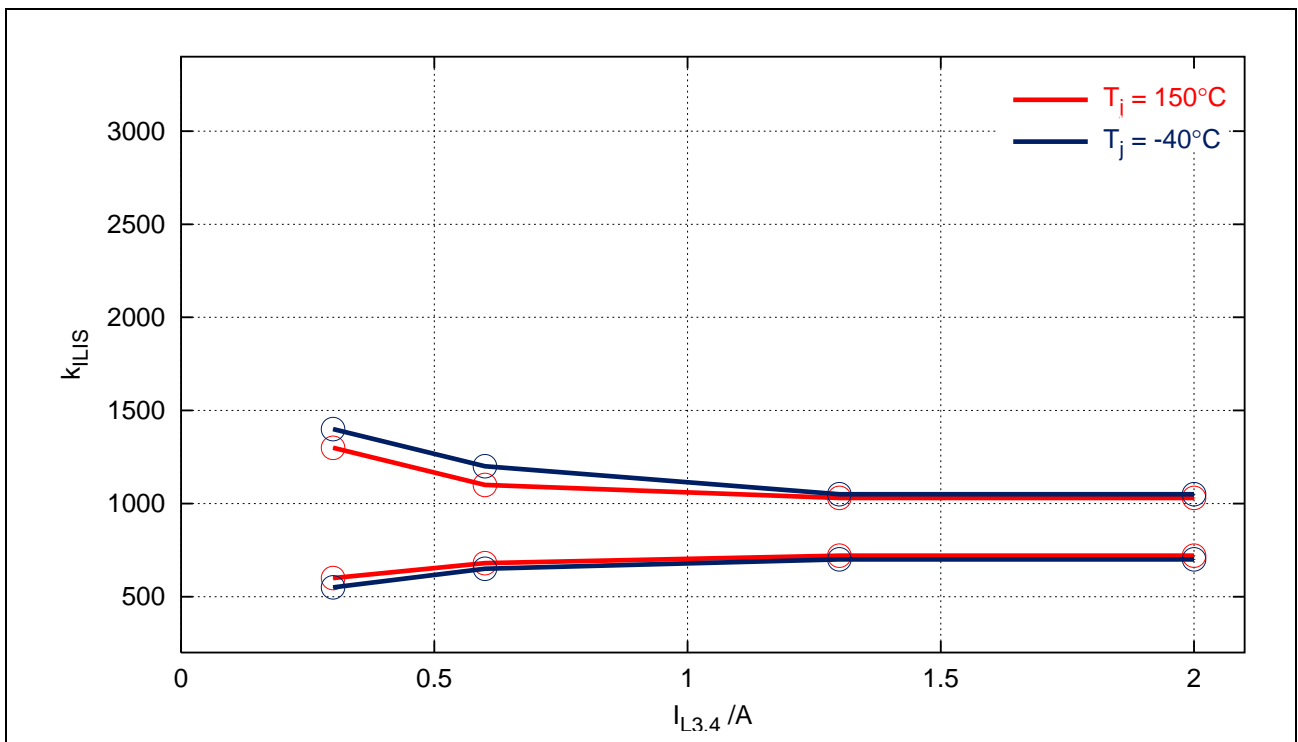

Figure 16 Current Sense Ratio k_{ILIS} Channel 3, 4 ¹⁾

1) The curves show the behavior based on characterization data. The marked points are guaranteed in this Data Sheet in [Section 4.4.4](#) (Position [4.4.1](#)).

In case of over current as well as over temperature, the current sense signal of the affected channel is switched off. To distinguish between over temperature and over load, the SPI diagnosis word can be used. Whereas the over load flag is cleared every time the diagnosis is transmitted, the over temperature flag is cleared by a dedicated SPI command (`HWCR.CTL`).

Details about timings between the current sense signal I_{IS} and the output voltage V_{OUT} and the load current I_L can be found in [Figure 17](#).

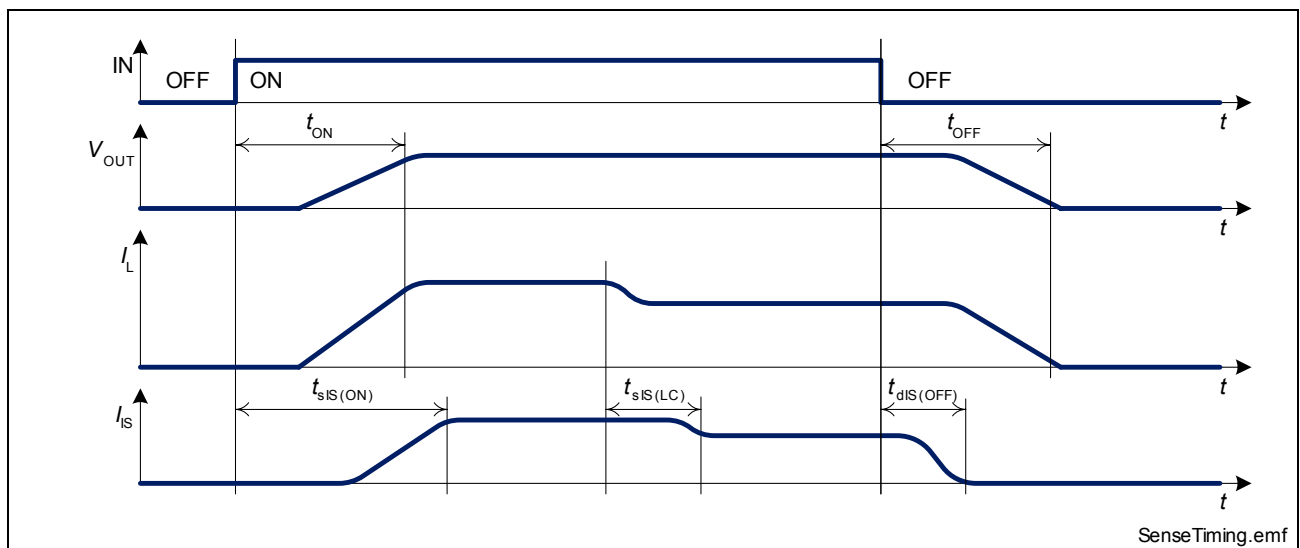

Figure 17 Timing of Current Sense Signal

Current Sense Multiplexer

There is a current sense multiplexer implemented in the SPOC - BTS 5590GX that routes the sense current of the selected channel to the diagnosis pin IS. The channel is selected via SPI register `DCR.MUX`. The sense current also can be disabled by SPI register `DCR.MUX`. For details on timing of the current sense multiplexer, please refer to [Figure 18](#).

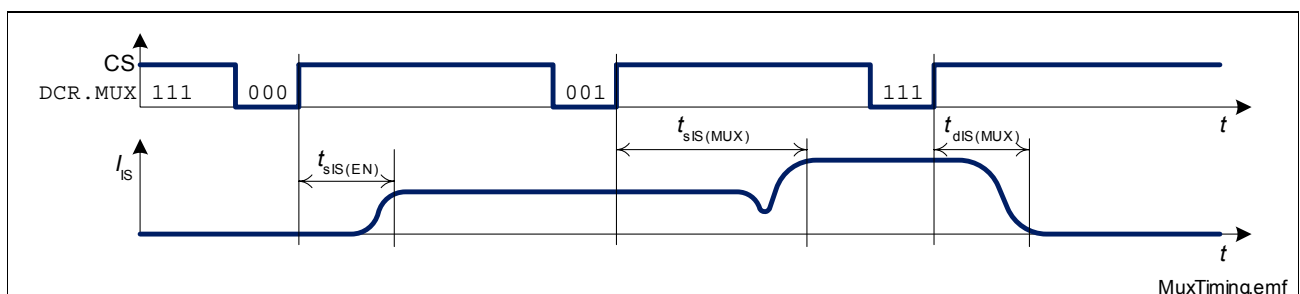

Figure 18 Timing of Current Sense Multiplexer

4.4.3 Switch Bypass Diagnosis

To detect short circuit to V_{bb} , there is a switch bypass monitor implemented. In case of short circuit between the output pin OUT and V_{bb} in ON-state, the current will flow through the power transistor as well as through the short circuit (bypass) with undefined ratio. As a result, the current sense signal will show lower values than expected by the load current. In OFF-state, the output voltage will stay close to V_{bb} potential which means a small V_{DS} .

The switch bypass monitor compares the voltage V_{DS} across the power transistor of that channel which is selected by the current sense multiplexer (DCR.MUX) with threshold $V_{DS(SB)}$. The result of comparison can be read in SPI register HWCR.SBM. The switch bypass monitor is active in ON- as well as in OFF-state.

4.4.4 Electrical Characteristics

Unless otherwise specified: $V_{bb} = 9\text{ V to }16\text{ V}$, $T_j = -40\text{ °C to }+150\text{ °C}$
 typical values: $V_{bb} = 13.5\text{ V}$, $T_j = 25\text{ °C}$

Pos.	Parameter	Symbol	Limit Values			Unit	Test Conditions
			min.	typ.	max.		
Load Current Sense							
4.4.1	Current sense ratio	k_{ILIS}					
	channel 0, 1 (bulb):						WDLR.LEDn = 0 $T_j = -40\text{ °C}$
	$I_L = 1.3\text{ A}$		2400		3800		
	$I_L = 2.6\text{ A}$		2400		3500		
	$I_L = 6.0\text{ A}$		2500		3500		
	$I_L = 1.3\text{ A}$		2450		3600		$T_j = 150\text{ °C}$
	$I_L = 2.6\text{ A}$		2450		3350		
	$I_L = 6.0\text{ A}$		2700		3300		
	channel 0,1 (LED):						WDLR.LEDn = 1 $T_j = -40\text{ °C}$
	$I_L = 35\text{ mA}$		400		2200		
	$I_L = 0.3\text{ A}$		600		1600		
	$I_L = 0.7\text{ A}$		650		1400		
	$I_L = 2.0\text{ A}$		750		1150		
	$I_L = 35\text{ mA}$		500		2000		$T_j = 150\text{ °C}$
	$I_L = 0.3\text{ A}$		650		1500		
$I_L = 0.7\text{ A}$	700		1300				
$I_L = 2.0\text{ A}$	800		1130				
channel 2 (bulb):					WDLR.LEDn = 0 $T_j = -40\text{ °C}$		
$I_L = 1.3\text{ A}$	2400		3800				
$I_L = 2.6\text{ A}$	2400		3500				
$I_L = 3.5\text{ A}$	2500		3500				
$I_L = 1.3\text{ A}$	2450		3600		$T_j = 150\text{ °C}$		
$I_L = 2.6\text{ A}$	2450		3350				
$I_L = 3.5\text{ A}$	2700		3300				

Unless otherwise specified: $V_{bb} = 9\text{ V to }16\text{ V}$, $T_j = -40\text{ °C to }+150\text{ °C}$
 typical values: $V_{bb} = 13.5\text{ V}$, $T_j = 25\text{ °C}$

Pos.	Parameter	Symbol	Limit Values			Unit	Test Conditions
			min.	typ.	max.		
	channel 2 (LED): $I_L = 35\text{ mA}$ $I_L = 0.3\text{ A}$ $I_L = 0.7\text{ A}$ $I_L = 1.3\text{ A}$ $I_L = 35\text{ mA}$ $I_L = 0.3\text{ A}$ $I_L = 0.7\text{ A}$ $I_L = 1.3\text{ A}$		400 600 650 750 500 650 700 800		2200 1600 1400 1150 2000 1500 1300 1130		WDLR.LEDn = 1 $T_j = -40\text{ °C}$ $T_j = 150\text{ °C}$
	channel 3, 4: $I_L = 0.3\text{ A}$ $I_L = 0.6\text{ A}$ $I_L = 1.3\text{ A}$ $I_L = 2.0\text{ A}$ $I_L = 0.3\text{ A}$ $I_L = 0.6\text{ A}$ $I_L = 1.3\text{ A}$ $I_L = 2.0\text{ A}$		550 650 700 700 600 680 720 720		1400 1200 1050 1050 1300 1100 1030 1030		$T_j = -40\text{ °C}$ $T_j = 150\text{ °C}$
4.4.2	Current sense voltage limitation	$V_{IS(LIM)}$	-8%	V_{dd}	8%	V	$I_{IS} = 1\text{ mA}$
4.4.3	Current sense leakage, while diagnosis disabled	$I_{IS(dis)}$			1	μA	$I_L = I_{L(nom)}$ DCR.MUX = 111 _B
4.4.4	Current sense settling time after channel activation	$t_{sIS(ON)}$			300 115	μs	$V_{bb} = 13.5\text{ V}$ $I_L = I_{L(nom)}$ $R_{IS} = 4.7\text{ k}\Omega$ WDLR.LEDn = 0 WDLR.LEDn = 1
4.4.5	Current sense desettling time after channel deactivation	$t_{dIS(OFF)}$			25 25	μs	$V_{bb} = 13.5\text{ V}^{1)}$ $I_L = I_{L(nom)}$ $R_{IS} = 4.7\text{ k}\Omega$ WDLR.LEDn = 0 WDLR.LEDn = 1

Unless otherwise specified: $V_{bb} = 9\text{ V to }16\text{ V}$, $T_j = -40\text{ °C to }+150\text{ °C}$
 typical values: $V_{bb} = 13.5\text{ V}$, $T_j = 25\text{ °C}$

Pos.	Parameter	Symbol	Limit Values			Unit	Test Conditions
			min.	typ.	max.		
4.4.6	Current sense settling time after change of load current channel 0, 1, 2 channel 3, 4	$t_{sIS(LC)}$			30 30	μs	$V_{bb} = 13.5\text{ V}$ ¹⁾ $R_{IS} = 4.7\text{ k}\Omega$ WDLR.LEDn = 0 $I_L = 1.3\text{ A to }2.6\text{ A}$ $I_L = 0.6\text{ A to }1.3\text{ A}$
4.4.7	Current sense settling time after current sense activation	$t_{sIS(EN)}$			25	μs	$R_{IS} = 4.7\text{ k}\Omega$ DCR.MUX: 111 _B -> 000 _B
4.4.8	Current sense settling time after multiplexer channel change	$t_{sIS(MUX)}$			30	μs	$R_{IS} = 4.7\text{ k}\Omega$ DCR.MUX: 000 _B -> 001 _B
4.4.9	Current sense deactivation time	$t_{dIS(MUX)}$			25	μs	$R_{IS} = 4.7\text{ k}\Omega$ DCR.MUX: ¹⁾ 001 _B -> 111 _B

Switch Bypass Monitor

4.4.10	Switch bypass monitor threshold	$V_{DS(SB)}$	0.7		2.5	V	
--------	---------------------------------	--------------	-----	--	-----	---	--

1) Not subject to production test, specified by design.

4.4.5 Command Description

DCR Diagnosis Control Registers

4	3	2	1	0
0	0	MUX		

Field	Bits	Type	Description
MUX	2:0	rw	Set Current Sense Multiplexer Configuration 000 current sense of channel 0 is routed to IS pin 001 current sense of channel 1 is routed to IS pin 010 current sense of channel 2 is routed to IS pin 011 current sense of channel 3 is routed to IS pin 100 current sense of channel 4 is routed to IS pin 101 IS pin is high impedance 110 IS pin is high impedance 111 IS pin is high impedance

HWCR Hardware Configuration Register

$\overline{W/R}$	4	3	2	1	0
read	LHO	WDL	SBM	PWM	CTL
write	RST	WDL	0	PWM	CTL

Field	Bits	Type	Description
SBM	2	r	Switch Bypass Monitor¹⁾ 0 $V_{DS} < V_{DS(SB)}$ 1 $V_{DS} > V_{DS(SB)}$

1) Invalid in stand-by mode

Standard Diagnosis

CS	7	6	5	4	3	2	1	0
TER	0	LHEN	WDL	ERR4	ERR4	ERR2	ERR1	ERR0

Field	Bits	Type	Description
ERRn n = 4 to 0	n	r	Error flag Channel n 0 normal operation 1 failure mode occurred

4.5 Limp Home

The SPOC - BTS 5590GX provides a sophisticated watchdog function with trigger state machine to build a secure limp home signalling. The fail safe block is supplied via V_{bb} and provides an output signal at pin LHO in case of watchdog overrun independently of V_{dd} . There is an enable pin LHEN available which is usually connected to the ignition signal of the car.

As soon as the limp home function is enabled, the watchdog is started and must be served. The timing can be adjusted in a wide range by choosing the appropriate capacitor. For calculation of the watchdog timing, please refer to [Section 4.5.1](#).

The watchdog is served via a trigger state machine, which starts at a defined state when limp home has been enabled. As a result, the state machine might also be reset to this startup state due to a voltage drop at pin LHEN.

A watchdog overrun causes the LHO pin to turn from tri-state to a high signal. This signal can be utilized to switch on dedicated channels by connecting LHO to the appropriate input pins and it is suitable to turn other hardware of the system into limp home mode as well. Once the watchdog has been overrun, it can be reset by a low signal at pin LHEN only. There is no software reset mechanism implemented for this function to make sure, a faulty software can not turn off the limp home mode.

The status of the watchdog as well as the trigger state machine can be read via SPI. As a result, the micro controller can perform a watchdog check via SPI.

Please see following [Figure 19](#) for details.

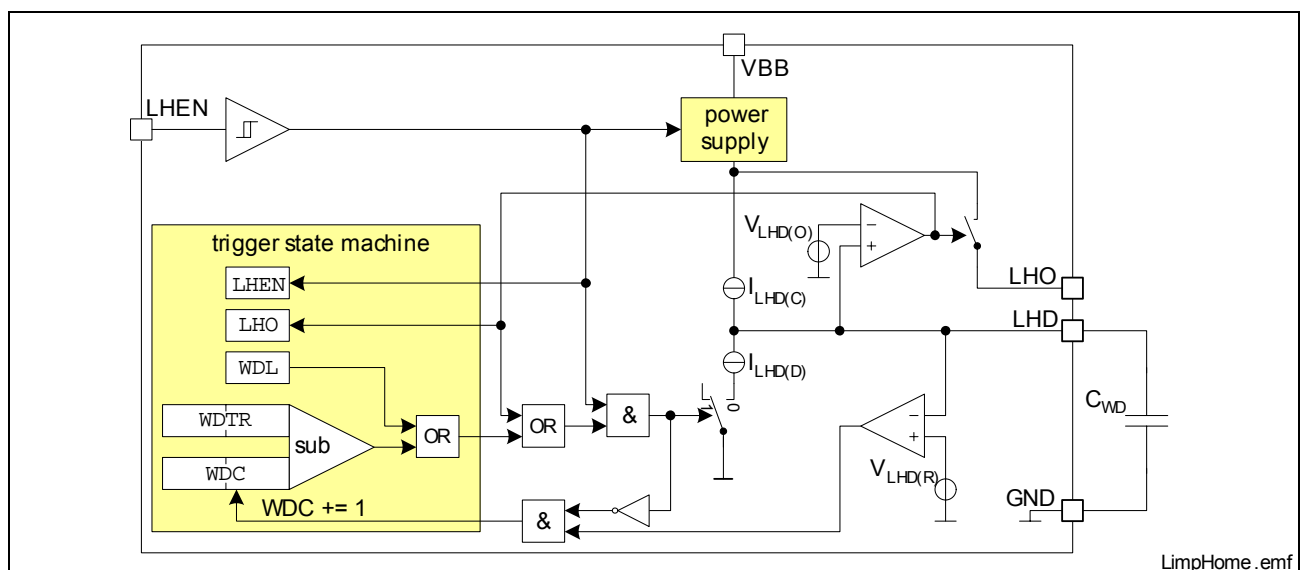

Figure 19 Block Diagram: Limp Home

4.5.1 Watchdog

The watchdog function is built as analog trigger watchdog with external capacitor C_{WD} as time base. A high signal at pin LHEN enables the watchdog. A constant current loads the external capacitor, so the voltage rise is linear. When the watchdog is served, the capacitor is discharged to level $V_{LHD(R)}$ and the cycle starts again. Please see following figure for details.

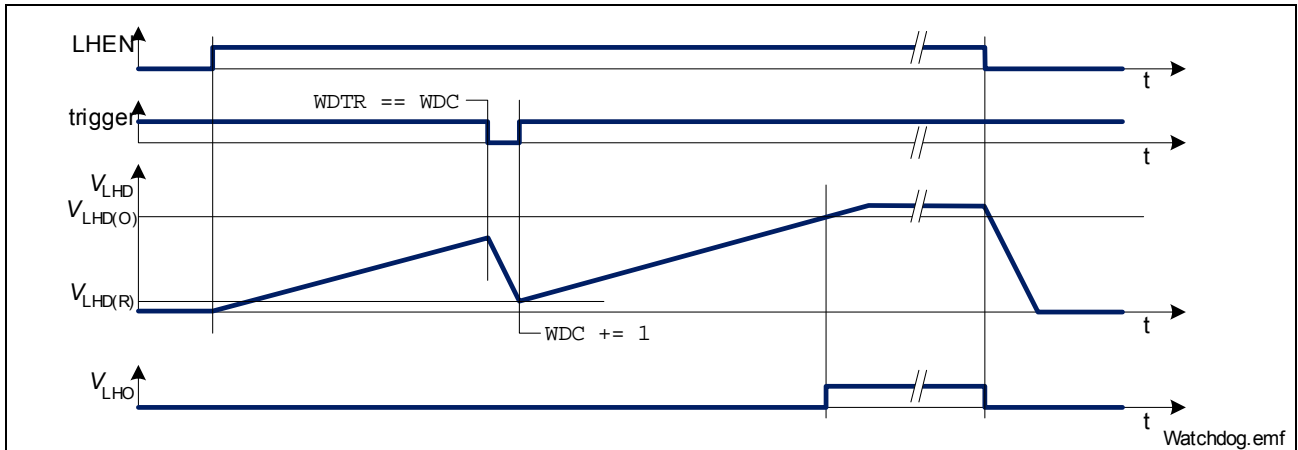

Figure 20 Watchdog Behavior

The limp home out signal (LHO) is generated, when the voltage at pin LHD exceeds threshold $V_{LHD(O)}$. In this case, all SPI registers are reset, but the read-only parameters (LHO , $ERRn$) are still available. The SPI interface including daisy chain capability is not affected by this reset signal. As a result it can be accessed normally.

The maximum watchdog serve time which is the minimum watchdog overrun time $t_{WD(O,min)}$ is calculated by following formula:

$$t_{WD(O,min)} = \frac{C_{WD(min)} \cdot (V_{LHD(O,min)} - V_{LHD(R,max)})}{I_{LHD(C,max)}} \quad (1)$$

The maximum watchdog overrun time $t_{WD(O,max)}$ is calculated by following formula:

$$t_{WD(O,max)} = \frac{C_{WD(max)} \cdot (V_{LHD(O,max)} - V_{LHD(R,min)})}{I_{LHD(C,min)}} \quad (2)$$

There is an under voltage reset implemented in the watchdog block. In case of V_{bb} lower than the operating voltage range of the watchdog (Position 4.1.2, $V_{bb(WD)}$), the LHO driver is deactivated and the external capacitor C_{WD} is discharged. As soon as the voltage rises above the under voltage threshold, the capacitor is charged again and the LHO driver is activated.

4.5.2 Trigger State Machine

A trigger state machine is implemented to ensure secure limp home signalling.

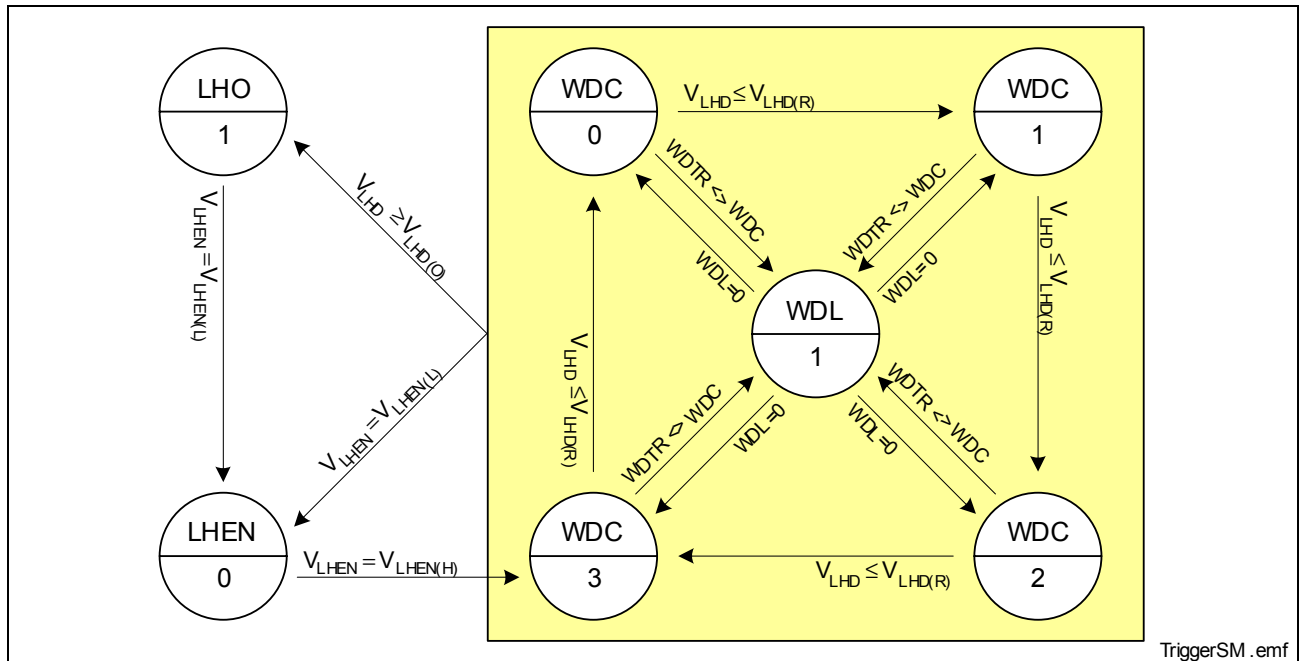

Figure 21 Trigger State Machine

There are two bits in the SPI register block ($DCR.WDTR$) that have to be subsequently increased to serve the watchdog. The $DWR.WDC$ parameter is increased by the device itself as soon as the capacitor is discharged below threshold $V_{LHD(R)}$.

The watchdog lock ($HWCR.WDL$) is set, when an incorrect $DCR.WDTR$ value ($DCR.WDTR \neq DCR.WDC$) has been written via SPI. To serve the watchdog then, the lock bit has to be cleared and the correct $DCR.WDTR$ value ($DCR.WDTR = DCR.WDC$) has to be written. The $HWCR.WDL$ bit is also part of the standard diagnosis (WDL) and can be monitored at each SPI access. The lock of the state machine trigger ensures that only correct handling will serve the watchdog. Any incorrect $DWR.WDTR$ value will lock the trigger for the watchdog, which will overrun after the specified timings.

The trigger state machine is reset to the default values (see [Section 4.6.6](#)) by the following events:

- Pin LHEN = low
- Pin LHO = 1 (limp home mode)
- The reset sources described in [Section 4.1.2](#)

4.5.3 Electrical Characteristics

Unless otherwise specified: $V_{bb} = 9\text{ V to }16\text{ V}$, $T_j = -40\text{ °C to }+150\text{ °C}$, $V_{LHEN} = 5\text{ V}$
 typical values: $V_{bb} = 13.5\text{ V}$, $T_j = 25\text{ °C}$

Pos.	Parameter	Symbol	Limit Values			Unit	Test Conditions
			min.	typ.	max.		

Limp Home

4.5.1	H-output voltage level of pin LHO	$V_{LHO(H)}$	5		9	V	$V_{LHD} = 5\text{ V}$ $I_{LHO} = 1\text{ mA}$
4.5.2	Current limitation of pin LHO	$I_{LHO(lim)}$	2			mA	$V_{LHD} = 5\text{ V}$

Watchdog

4.5.3	Charge current for C_{WD}	$I_{LHD(C)}$	15	22	30	μA	
4.5.4	Discharge current for C_{WD}	$-I_{LHD(D)}$	300			μA	
4.5.5	Overrun threshold voltage at pin LHD	$V_{LHD(O)}$	4.0	4.4	4.8	V	
4.5.6	Recharge threshold voltage at pin LHD	$V_{LHD(R)}$	0.4	0.5	0.6	V	

Input Characteristics

4.5.7	L-input level at pin LHEN	$V_{LHEN(L)}$	-0.3		1.0	V	
4.5.8	H-input level at pin LHEN	$V_{LHEN(H)}$	2.6		5.5	V	
4.5.9	L-input current through pin LHEN	$I_{LHEN(L)}$	3		85	μA	$V_{LHEN} = 0.4\text{ V}$
4.5.10	H-input current through pin LHEN	$I_{LHEN(H)}$	7	30	85	μA	$V_{LHEN} = 5\text{ V}$

4.5.4 Command Description

WDLR

Watchdog and LED Mode Configuration Register

W/R	4	3	2	1	0
read	WDC		LED2	LED1	LED0
write	WDTR		LED2	LED1	LED0

Field	Bits	Type	Description
WD	4:3		Watchdog Trigger State Machine
WDC		r	11 Watchdog trigger state machine counter (read only)
WDTR		w	00 Watchdog trigger register (write only)

HWCR

Hardware Configuration Register

W/R	4	3	2	1	0
read	LHO	WDL	SBM	PWM	CTL
write	RST	WDL	0	PWM	CTL

Field	Bits	Type	Description
LHO	4	r	Limp Home Out 0 Device is in normal operation mode 1 Device is in limp home mode
WDL	3	rw	Watchdog Lock 0 Watchdog can be served 1 Watchdog state machine trigger is locked

Standard Diagnosis

CS	7	6	5	4	3	2	1	0
TER	0	LHEN	WDL	ERR4	ERR4	ERR2	ERR1	ERR0

Field	Bits	Type	Description
LHEN	6		Limp Home Enable 0 L-input signal at pin LHEN 1 H-input signal at pin LHEN
WDL	5		Watchdog Lock 0 Watchdog can be served 1 Watchdog trigger state machine is locked

4.6 Serial Peripheral Interface (SPI)

The serial peripheral interface (SPI) is a full duplex synchronous serial slave interface, which uses four lines: SO, SI, SCLK and \overline{CS} . Data is transferred by the lines SI and SO at the rate given by SCLK. The falling edge of \overline{CS} indicates the beginning of an access. Data is sampled in on line SI at the falling edge of SCLK and shifted out on line SO at the rising edge of SCLK. Each access must be terminated by a rising edge of \overline{CS} . A modulo 8 counter ensures that data is taken only, when a multiple of 8 bit has been transferred. The interface provides daisy chain capability.

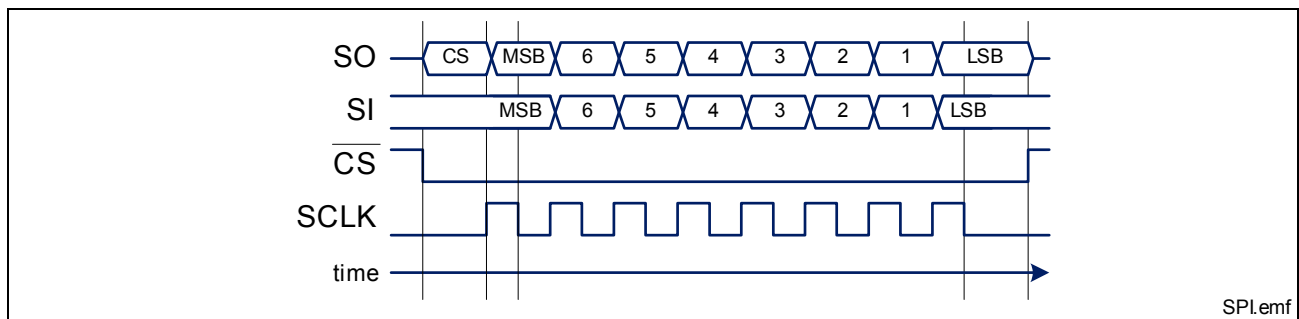

Figure 22 Serial Peripheral Interface

4.6.1 SPI Signal Description

\overline{CS} - Chip Select: The system micro controller selects the SPOC - BTS 5590GX by means of the \overline{CS} pin. Whenever the pin is in low state, data transfer can take place. When \overline{CS} is in high state, any signals at the SCLK and SI pins are ignored and SO is forced into a high impedance state.

\overline{CS} High to Low transition: 

- The requested information is transferred into the shift register.
- SO changes from high impedance state to high or low state depending on the logic OR combination between the transmission error flag (TER) and the signal level at pin SI. As a result, even in daisy chain configuration, a high signal indicates a faulty transmission. This information stays available to the first rising edge of SCLK.

\overline{CS} Low to High transition: 

- Command decoding is only done, when after the falling edge of \overline{CS} exactly a multiple (1, 2, 3, ...) of eight SCLK signals have been detected. In case of faulty transmission, the transmission error flag (TER) is set and the command is ignored.
- Data from shift register is transferred into the addressed register.

SCLK - Serial Clock: This input pin clocks the internal shift register. The serial input (SI) transfers data into the shift register on the falling edge of SCLK while the serial output

Serial Peripheral Interface (SPI)

(SO) shifts diagnostic information out on the rising edge of the serial clock. It is essential that the SCLK pin is in low state whenever chip select CS makes any transition.

SI - Serial Input: Serial input data bits are shift-in at this pin, the most significant bit first. SI information is read on the falling edge of SCLK. The input data consists of two parts, control bits followed by data bits. Please refer to [Section 4.6.5](#) for further information.

SO Serial Output: Data is shifted out serially at this pin, the most significant bit first. SO is in high impedance state until the CS pin goes to low state. New data will appear at the SO pin following the rising edge of SCLK. Please refer to [Section 4.6.5](#) for further information.

4.6.2 Daisy Chain Capability

The SPI of SPOC - BTS 5590GX provides daisy chain capability. In this configuration several devices are activated by the same CS signal MCS. The SI line of one device is connected with the SO line of another device (see [Figure 23](#)), in order to build a chain. The ends of the chain are connected with the output and input of the master device, MO and MI respectively. The master device provides the master clock MCLK which is connected to the SCLK line of each device in the chain.

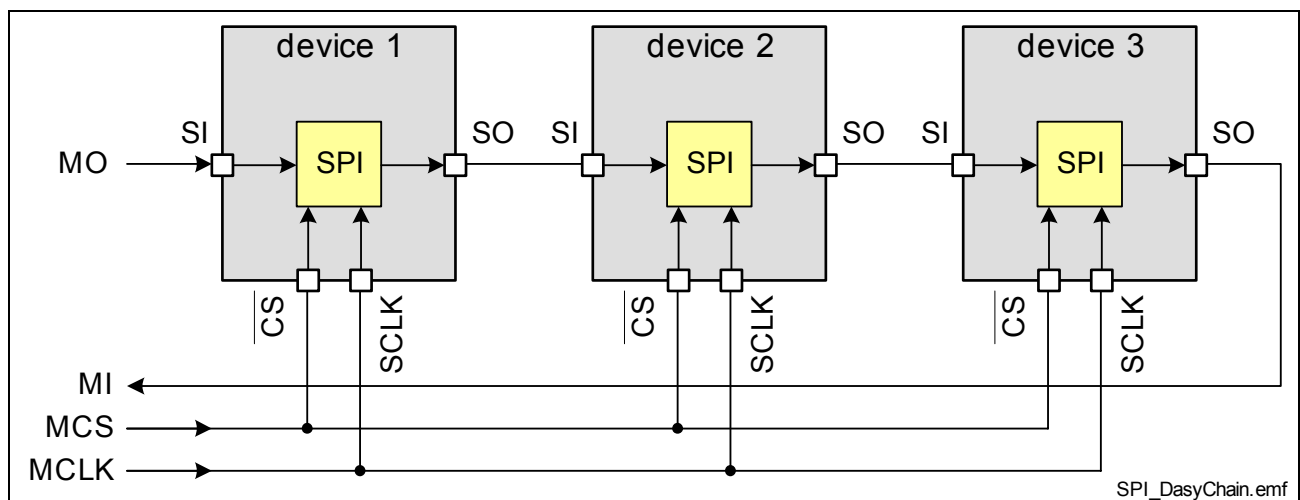

Figure 23 Daisy Chain Configuration

In the SPI block of each device, there is one shift register where one bit from SI line is shifted in each SCLK. The bit shifted out occurs at the SO pin. After eight SCLK cycles, the data transfer for one device has been finished. In single chip configuration, the CS line must turn high to make the device accept the transferred data. In daisy chain configuration, the data shifted out at device 1 has been shifted in to device 2. When using three devices in daisy chain, three times eight bits have to be shifted through the devices. After that, the MCS line must turn high (see [Figure 24](#)).

Serial Peripheral Interface (SPI)

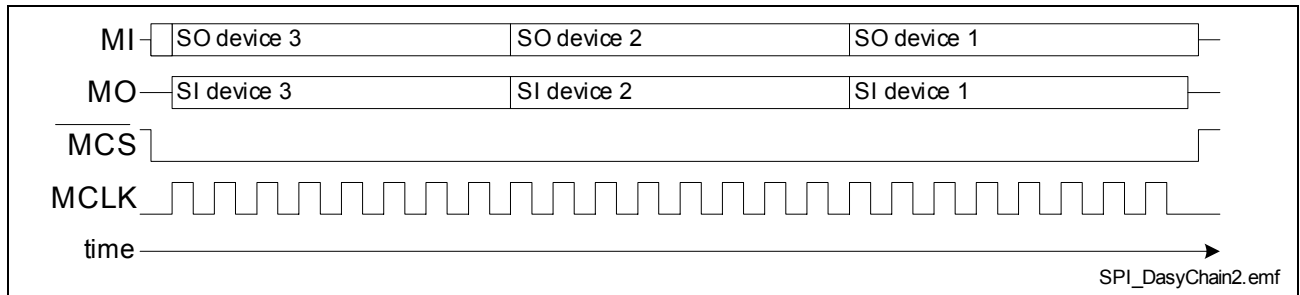

Figure 24 Data Transfer in Daisy Chain Configuration

4.6.3 Timing Diagrams

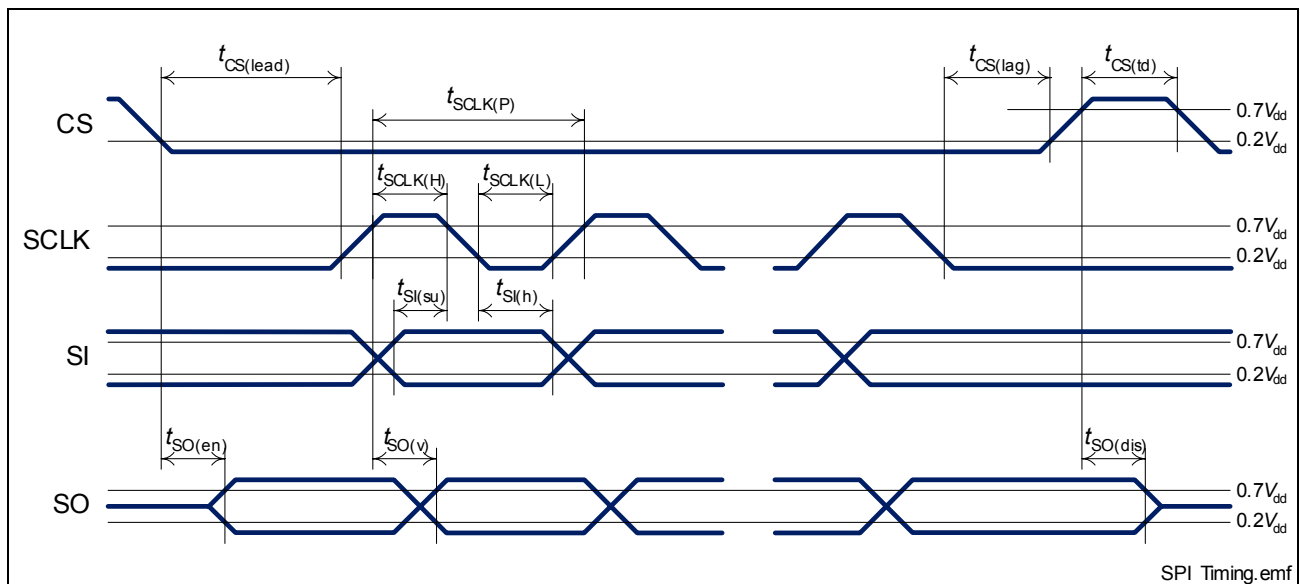

Figure 25 Timing Diagram SPI Access

4.6.4 Electrical Characteristics

Unless otherwise specified: $V_{bb} = 9\text{ V to }16\text{ V}$, $T_j = -40\text{ °C to }+150\text{ °C}$, $V_{dd} = 3.8\text{ V to }5.5\text{ V}$
 typical values: $V_{bb} = 13.5\text{ V}$, $T_j = 25\text{ °C}$, $V_{dd} = 4.3\text{ V}$

Pos.	Parameter	Symbol	Limit Values			Unit	Test Conditions
			min.	typ.	max.		

Input Characteristics (CS, SCLK, SI)

4.6.1	L level of pin $\overline{\text{CS}}$ SCLK SI	$V_{\text{CS(L)}}$ $V_{\text{SCLK(L)}}$ $V_{\text{SI(L)}}$	-0.3		1.0	V	$V_{\text{dd}} = 4.3\text{ V}$
4.6.2	H level of pin $\overline{\text{CS}}$ SCLK SI	$V_{\text{CS(H)}}$ $V_{\text{SCLK(H)}}$ $V_{\text{SI(H)}}$	2.6		5.5	V	$V_{\text{dd}} = 4.3\text{ V}$
4.6.3	L-input pull-up current at $\overline{\text{CS}}$ pin	$I_{\text{CS(L)}}$	10	30	85	μA	$V_{\text{dd}} = 4.3\text{ V}$ $V_{\text{CS}} = 0\text{ V}$
4.6.4	H-input pull-up current at $\overline{\text{CS}}$ pin	$I_{\text{CS(H)}}$	3		85	μA	$V_{\text{dd}} = 4.3\text{ V}$ $V_{\text{CS}} = 2.6\text{ V}$
4.6.5	L-input pull-down current at pin SCLK SI	$I_{\text{SCLK(L)}}$ $I_{\text{SI(L)}}$	3		75	μA	$V_{\text{dd}} = 4.3\text{ V}$ $V_{\text{SCLK}} = 0.4\text{ V}$ $V_{\text{SI}} = 0.4\text{ V}$
4.6.6	H-input pull-down current at pin SCLK SI	$I_{\text{SCLK(H)}}$ $I_{\text{SI(H)}}$	10	30	75	μA	$V_{\text{dd}} = 4.3\text{ V}$ $V_{\text{SCLK}} = 4.3\text{ V}$ $V_{\text{SI}} = 4.3\text{ V}$

Output Characteristics (SO)

4.6.7	L level output voltage	$V_{\text{SO(L)}}$	0		0.5	V	$I_{\text{SO}} = -0.5\text{ mA}$
4.6.8	H level output voltage	$V_{\text{SO(H)}}$	$V_{\text{dd}} - 0.5\text{ V}$		V_{dd}	V	$I_{\text{SO}} = 0.5\text{ mA}$ $V_{\text{dd}} = 4.3\text{ V}$
4.6.9	Output tristate leakage current	$I_{\text{SO(OFF)}}$	-10		10	μA	$V_{\text{CS}} = V_{\text{dd}}$

Timings

4.6.10	Serial clock frequency	f_{SCLK}	0		1	MHz	
4.6.11	Serial clock period	$t_{\text{SCLK(P)}}$	1			μs	
4.6.12	Serial clock high time	$t_{\text{SCLK(H)}}$	500			ns	

Serial Peripheral Interface (SPI)

Unless otherwise specified: $V_{bb} = 9\text{ V to }16\text{ V}$, $T_j = -40\text{ °C to }+150\text{ °C}$, $V_{dd} = 3.8\text{ V to }5.5\text{ V}$
 typical values: $V_{bb} = 13.5\text{ V}$, $T_j = 25\text{ °C}$, $V_{dd} = 4.3\text{ V}$

Pos.	Parameter	Symbol	Limit Values			Unit	Test Conditions
			min.	typ.	max.		
4.6.13	Serial clock low time	$t_{\text{SCLK(L)}}$	500			ns	
4.6.14	Enable lead time (falling $\overline{\text{CS}}$ to rising SCLK)	$t_{\text{CS(lead)}}$	1			μs	
4.6.15	Enable lag time (falling SCLK to rising $\overline{\text{CS}}$)	$t_{\text{CS(lag)}}$	1			μs	
4.6.16	Transfer delay time (rising $\overline{\text{CS}}$ to falling $\overline{\text{CS}}$)	$t_{\text{CS(td)}}$	2			μs	
4.6.17	Data setup time (required time SI to falling SCLK)	$t_{\text{SI(su)}}$	100			ns	
4.6.18	Data hold time (falling SCLK to SI)	$t_{\text{SI(h)}}$	100			ns	
4.6.19	Output enable time (falling $\overline{\text{CS}}$ to SO valid)	$t_{\text{SO(en)}}$			1	μs	$C_L = 20\text{ pF}^{1)}$
4.6.20	Output disable time (rising $\overline{\text{CS}}$ to SO tri-state)	$t_{\text{SO(dis)}}$			1	μs	$C_L = 20\text{ pF}^{1)}$
4.6.21	Output data valid time with capacitive load	$t_{\text{SO(v)}}$			500	ns	$C_L = 20\text{ pF}^{1)}$

1) Not subject to production test, specified by design.

4.6.5 SPI Protocol

CS ¹⁾	7	6	5	4	3	2	1	0
------------------	---	---	---	---	---	---	---	---

Write Register

SI	1	ADDR	DATA					
----	---	------	------	--	--	--	--	--

Read Register

SI	0	ADDR	x	x	x	x	0
----	---	------	---	---	---	---	---

Read Standard Diagnosis

SI	0	x	x	x	x	x	x	1
----	---	---	---	---	---	---	---	---

Standard Diagnosis

SO	TER	0	LHEN	WDL	ERR4	ERR3	ERR2	ERR1	ERR0
----	-----	---	------	-----	------	------	------	------	------

Second Frame of Read Command

SO	TER	1	ADDR	DATA					
----	-----	---	------	------	--	--	--	--	--

1) The SO pin shows this information between \overline{CS} hi -> lo and first SCLK lo -> hi transition.

Note: Reading a register needs two SPI frames. In the first frame the RD command is sent. In the second frame the output at SPI signal SO will contain the requested information. A new command can be executed in the second frame.

Field	Bits	Type	Description
TER	CS	r	Transmission Error 0 Previous transmission was successful (modulo 8 clocks received) 1 Previous transmission failed or first transmission after reset
ADDR	6:5	rw	Address Pointer to register for read and write command
DATA	4:0	rw	Data Data written to or read from register selected by address ADDR
LHEN	6	r	Limp Home Enable 0 L-input signal at pin LHEN 1 H-input signal at pin LHEN
WDL	5	r	Watchdog Lock 0 Watchdog can be served 1 Watchdog trigger state machine is locked

Serial Peripheral Interface (SPI)

Field	Bits	Type	Description
ERRx x = 4 to 0	x	r	Diagnosis of Channel x 0 No failure 1 Over temperature, over load or short circuit

4.6.6 Register Overview

Name	W/R	Addr	4	3	2	1	0	default ¹⁾
OUT	W/R	00 _B	OUT4	OUT3	OUT2	OUT1	OUT0	00 _H
WDLR	R	01 _B	WDC		LED2	LED1	LED0	18 _H
	W	01 _B	WDTR		LED2	LED1	LED0	00 _H
HWCR	R	10 _B	LHO	WDL	SBM	PWM	CTL	00 _H
	W	10 _B	RST	WDL ²⁾	0	PWM	CTL	00 _H
DCR	W/R	11 _B	0	0	MUX			07 _H

1) The default values are set after reset.

2) Can be cleared only via SPI. The bit is set by internal signals.

5 Application Description

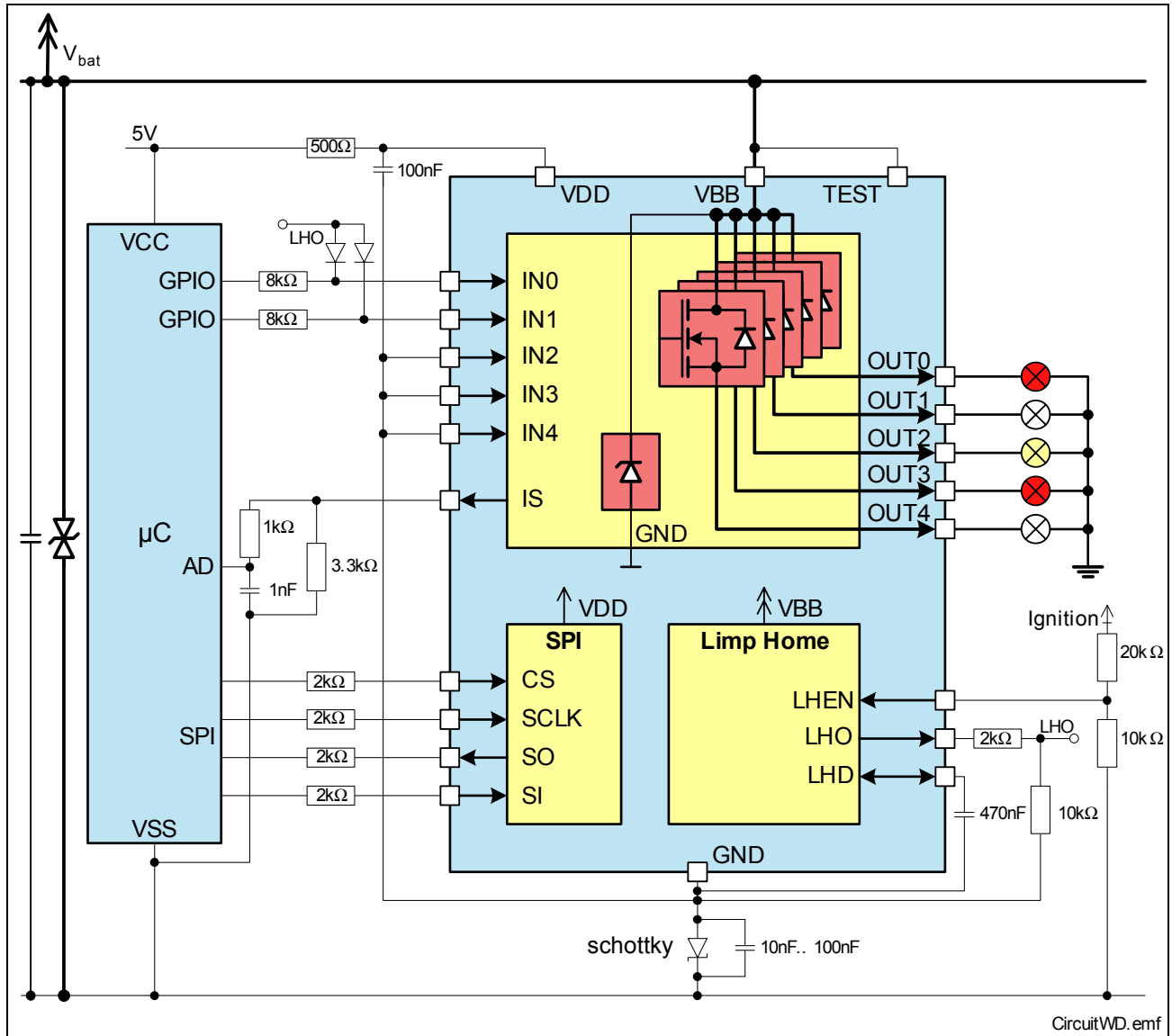

Figure 26 Application Circuit Example

6 Package Outlines SPOC - BTS 5590GX

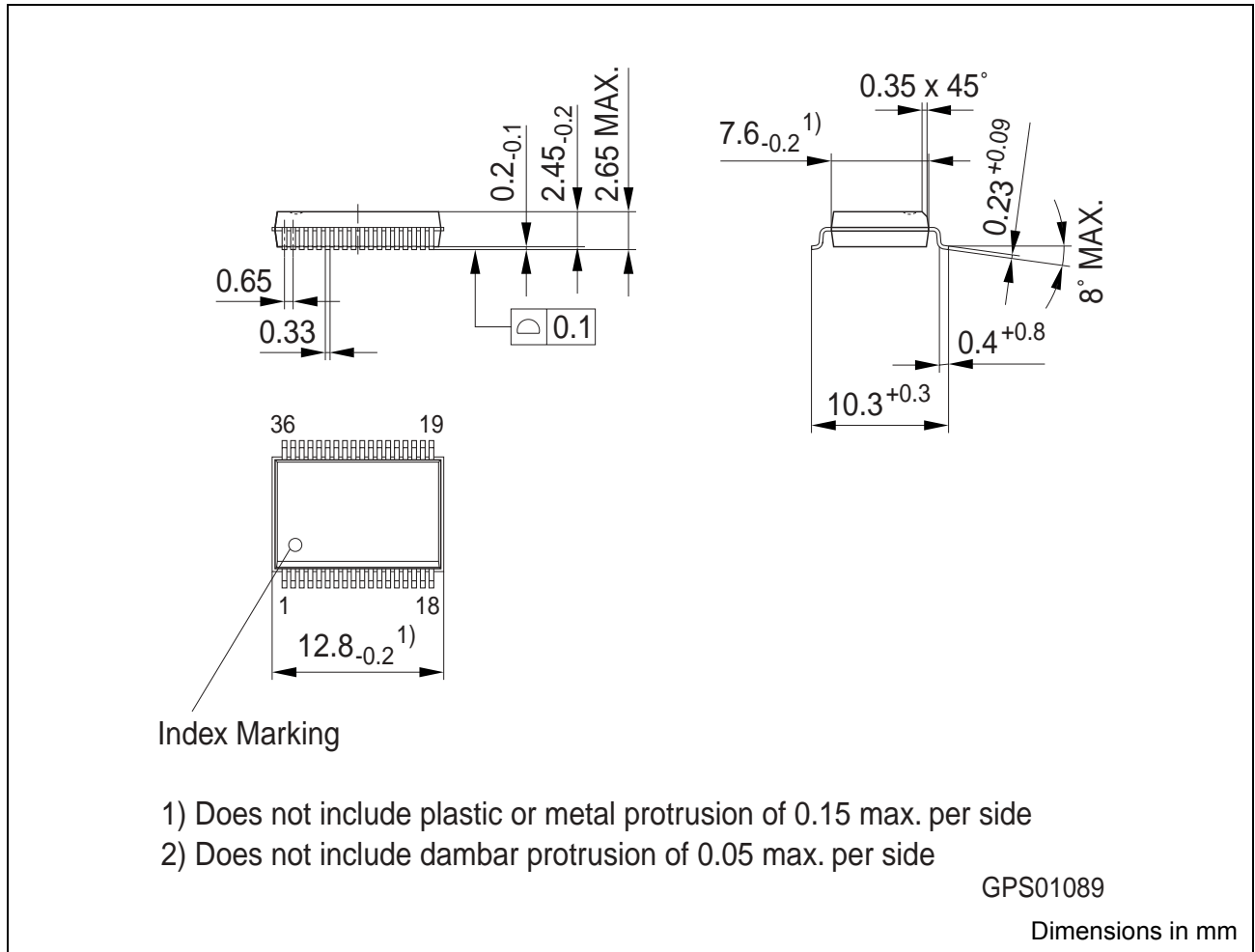

Figure 27 P-DSO-36-20 (Plastic Dual Small Outline Package)

You can find all of our packages, sorts of packing and others in our Infineon Internet Page "Products": <http://www.infineon.com/products>.

7 Revision History

Version	Date	Changes
V1.1	06-09-20	page 18: register read value added



Edition 2006-09-20

**Published by
Infineon Technologies AG
81726 München, Germany**

**© Infineon Technologies AG 2006.
All Rights Reserved.**

Legal Disclaimer

The information given in this document shall in no event be regarded as a guarantee of conditions or characteristics ("Beschaffenheitsgarantie"). With respect to any examples or hints given herein, any typical values stated herein and/or any information regarding the application of the device, Infineon Technologies hereby disclaims any and all warranties and liabilities of any kind, including without limitation warranties of non-infringement of intellectual property rights of any third party.

Information

For further information on technology, delivery terms and conditions and prices please contact your nearest Infineon Technologies Office (www.infineon.com).

Warnings

Due to technical requirements components may contain dangerous substances. For information on the types in question please contact your nearest Infineon Technologies Office.

Infineon Technologies Components may only be used in life-support devices or systems with the express written approval of Infineon Technologies, if a failure of such components can reasonably be expected to cause the failure of that life-support device or system, or to affect the safety or effectiveness of that device or system. Life support devices or systems are intended to be implanted in the human body, or to support and/or maintain and sustain and/or protect human life. If they fail, it is reasonable to assume that the health of the user or other persons may be endangered.

<http://www.infineon.com>

Published by Infineon Technologies AG