

Amphenol

PPS

Push Pull Series



The PPS is a miniature connector with push pull technology and RoHS compliant. It is designed for use on equipment that is not submersed or left exposed to the elements for prolonged periods, within Industrial and Ground Harsh Environment applications. To mate, the plug is pushed onto the receptacle. The connector is locked in its rest position and is released by pulling back the coupling nut.

The PPS has a small outside diameter and several inserts are available, including high-density insert arrangements. The plugs can be fitted with EMC grounding fingers for increased screening effectiveness. Amphenol Ltd offers full cable harness solutions with overmoulding capabilities or, where preferred, a heat shrink boot can be used.

The plug has a black silver body and backshell with a black coupling nut. Other plating finishes available are electroless nickel and both are chemical and NBC resistant. Receptacles are available in black silver plating as standard and electroless nickel. All metalwork is machined from brass for increased mating durability.

Amphenol

Visit our Website @
www.amphenol.co.uk

RECEPTACLES – SOCKET CONTACTS ONLY

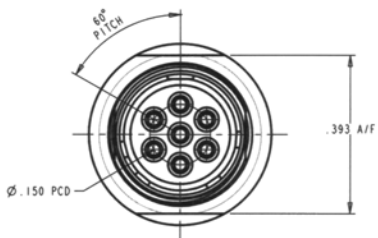

FRONT FACE VIEW
PPS 7 WAY

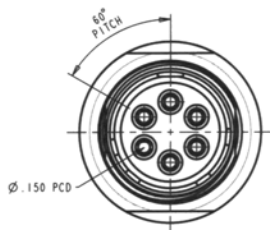

FRONT FACE VIEW
PPS 6 WAY

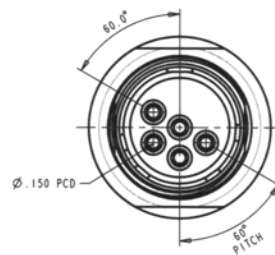

FRONT FACE VIEW
PPS 5 WAY

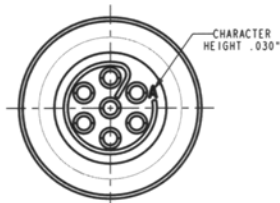

REAR FACE VIEW
PPS 7 WAY

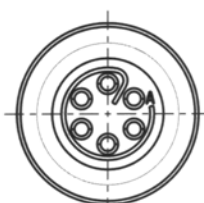

REAR FACE VIEW
PPS 6 WAY

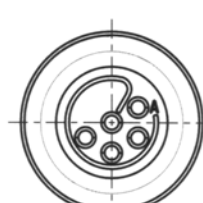

REAR FACE VIEW
PPS 5 WAY

PLUGS – PIN CONTACTS ONLY

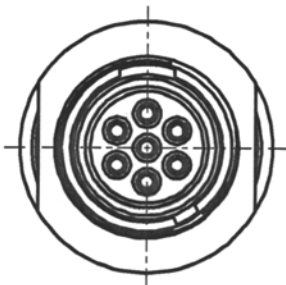

FRONT FACE VIEW
PPS 7 WAY

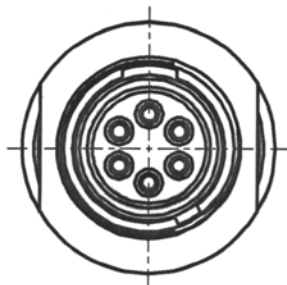

FRONT FACE VIEW
PPS 6 WAY

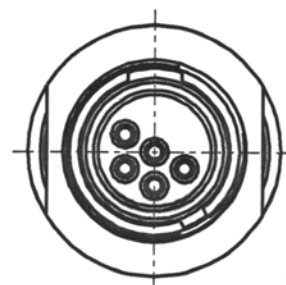

FRONT FACE VIEW
PPS 5 WAY

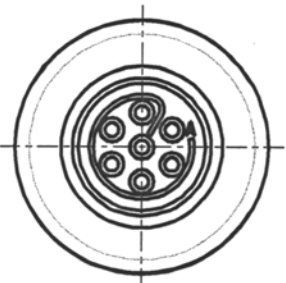

REAR FACE VIEW
PPS 7 WAY

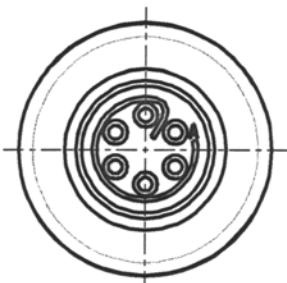

REAR FACE VIEW
PPS 6 WAY

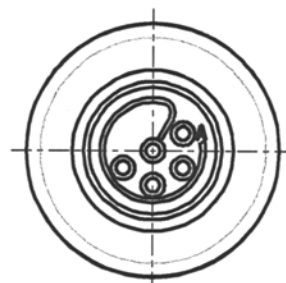

REAR FACE VIEW
PPS 5 WAY

Insert Availability / Specifications

INSERT AVAILABILITY	
05-05	5 # 22 AWG Contacts
05-06	6 # 22 AWG Contacts
05-07	7 # 22 AWG Contacts

CONTACT SPECIFICATIONS		
Contact Resistance	5 mΩ initially	Less than 10 mΩ
Shell to Shell Conductivity	5 mΩ initially	Less than 10 mΩ

INSERT SPECIFICATIONS	
Contact Arrangement	05-05 / 05-06 / 05-07
Working Voltage (Sea Level)	115 Vac
DWV (Sea Level)	500 Vac
Insulation Resistance (Sea Level)	1GΩ @ 500 Vdc
Current Rating (Individual Contact)	3A
Current Rating (all Contacts Simultaneously)	1A

ENVIRONMENTAL	
Temperature	-55°C / +85°C
Salt Spray	500 hours subject to selected plating finish
Fluids	As per MIL-C-26482 Series I
Vibration and Shock	MIL-C-26482 Series I
Sealing	IP67 Unmated Bulkhead Connectors
	IP64 Mated Pair Interface

MECHANICAL	
Durability	1000 Matings
Materials	Shell : Brass – See Part No. information for plating options
	Contacts : Turned, Gold Plated
	Inserts and Seal : Proprietary Thermoplastic Polyester Elastomer

Table of Styles - Receptacles

PPS-07A05-XXSX-001(970)

Jam Nut Receptacle
PCB Contacts

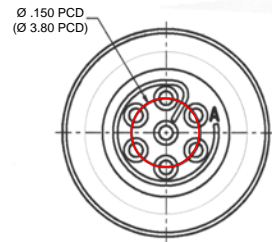
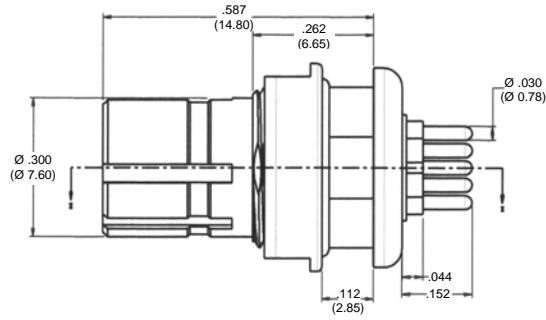
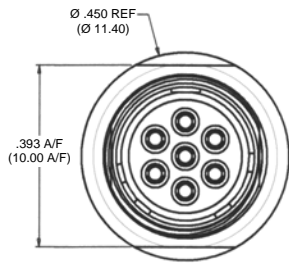
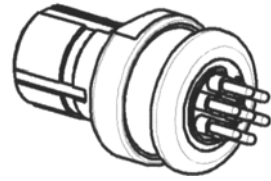

Panel Nut - Torque to 2.25Nm = 1.65 foot pounds force

All Dimensions are for reference only
(Dimensions in brackets are in mm)

PPS-07A05-XXSX-002(970)

Jam Nut Receptacle
Solder Bucket Contacts

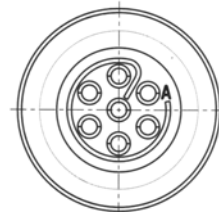
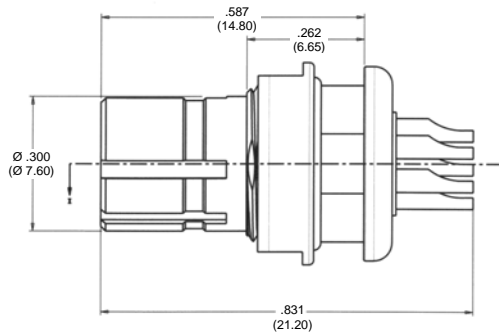
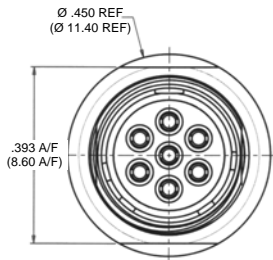
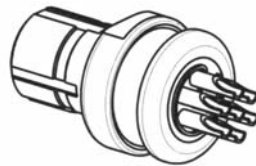

Panel Nut - Torque to 2.25Nm = 1.65 foot pounds force

All Dimensions are for reference only
(Dimensions in brackets are in mm)

Table of Styles - Receptacles

PPS-01T05-XXSX-002(970)

In Line Receptacle
Solder Bucket Contacts

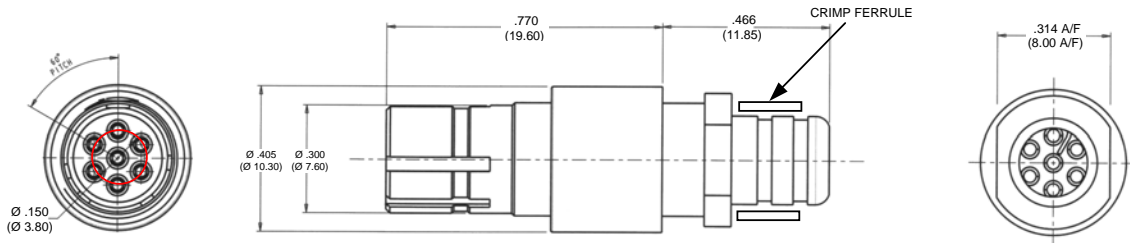

All Dimensions are for reference only
(Dimensions in brackets are in mm)

PPS-02T05-XXSX-002(970)

2 Hole Mounting Receptacle
Solder Bucket Contacts

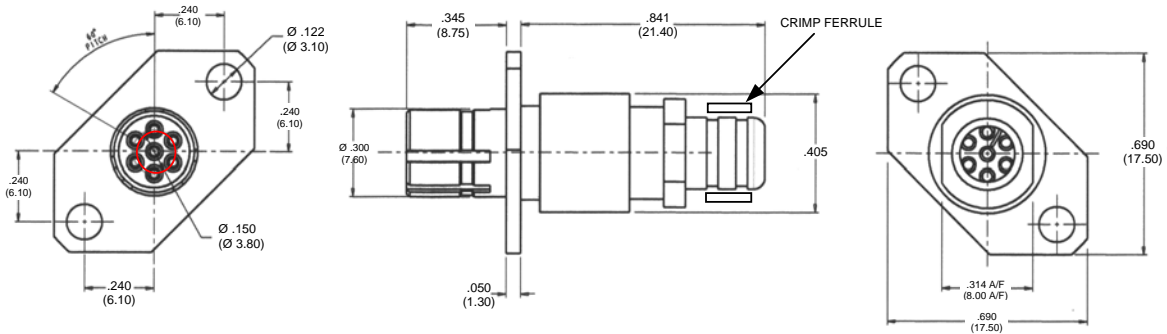
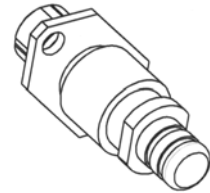

All Dimensions are for reference only
(Dimensions in brackets are in mm)

Table of styles - Receptacles

PPS-02A05-XXSX-001(970)

2 Hole Panel Mount Receptacle
Pin Tail Contacts

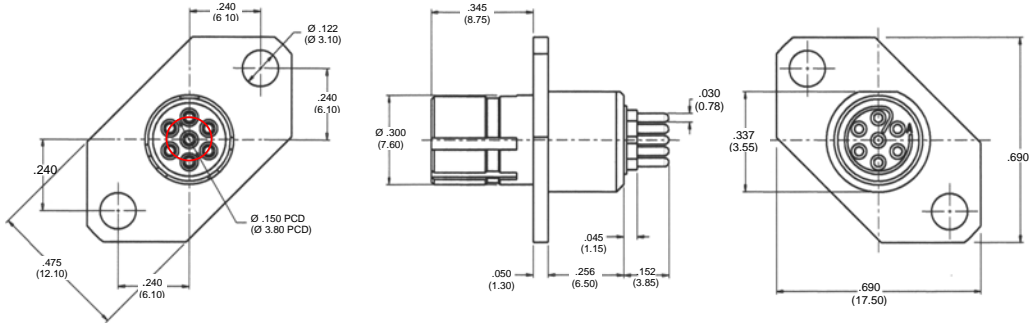
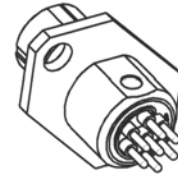
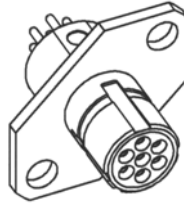

All Dimensions are for reference only
(Dimensions in brackets are in mm)

PPS-02A05-XXSX-002(970)

2 Hole Panel Mount Receptacle
Solder Bucket Contacts

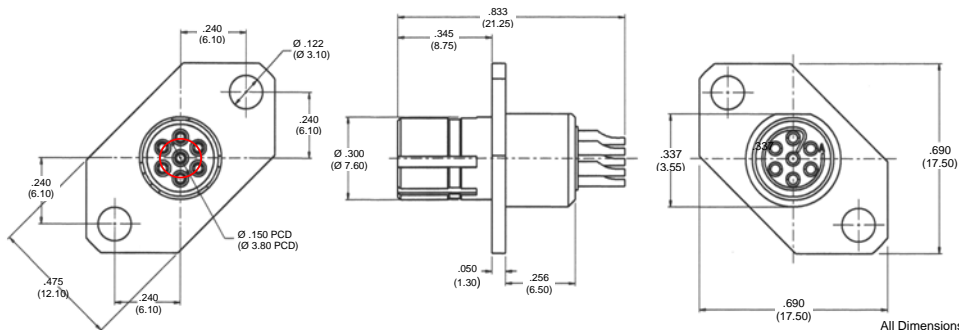
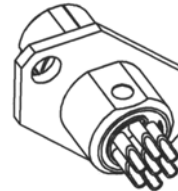

All Dimensions are for reference only
(Dimensions in brackets are in mm)

390-0122-01

2 Hole Panel Mount Receptacle Gasket

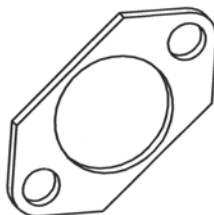

Used on PPS-02T and PPS-02A

All Dimensions are for reference only
(Dimensions in brackets are in mm)

Cut Out Details

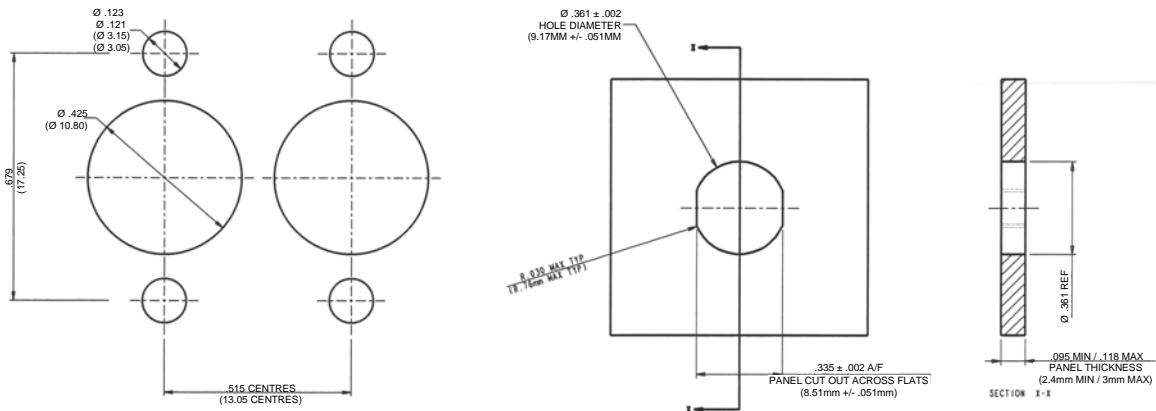

All Dimensions are for reference only
(Dimensions in brackets are in mm)

390-5013
Receptacle Dust Cap – Colour Black

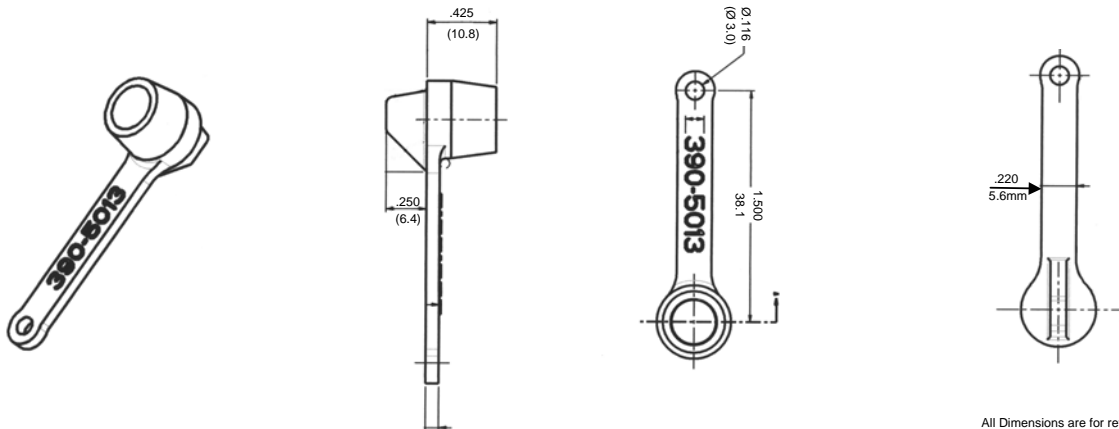

All Dimensions are for reference only
(Dimensions in brackets are in mm)

PPS-6XXX-XXX

Jam Nut Receptacle to Header Assembly

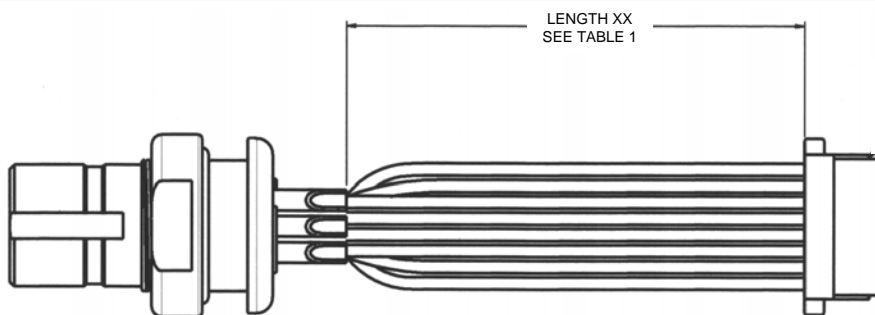

MATING HALF
CONNECTOR
RS-311-6546

VARIANT	LENGTH XXX
.025	25MM
.050	50MM
.075	75MM
.100	100MM
.125	125MM
.150	150MM

Panel Nut - Torque to 2.25Nm = 1.65 foot pounds force

Please contact Amphenol Ltd for full part numbering information

This is available with the following PPS Receptacle styles and in all Inserts: PPS-07A, PPS-01T, PPS-02A

PPS-06T05-XXPX-XXX

Non Grounded Plug complete with Backshell and optional Crimp Ferrule

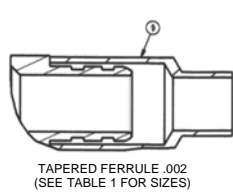
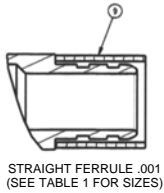
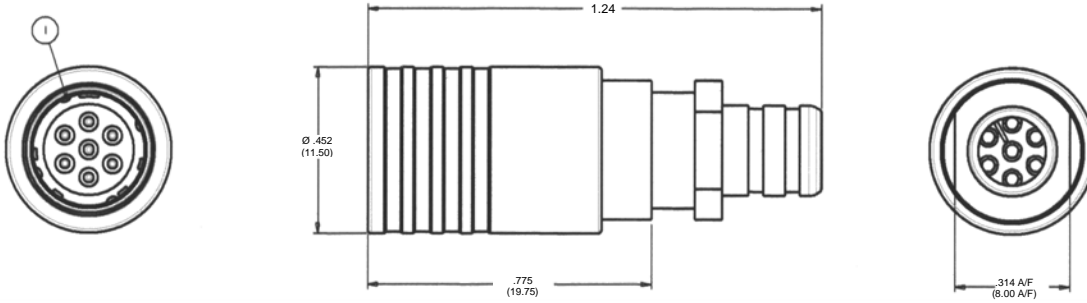
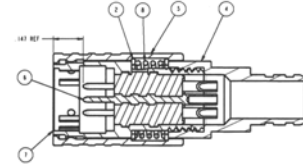
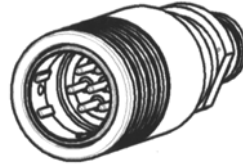

TABLE 1	
PART NUMBER	MAX. CABLE DIAMETER FOR FERRULE
PPS-06T05-XXPX-001	6.5MM
PPS-06T05-XXPX-002	4.3MM
PPS-06T05-XXPX-003	3.2MM

Torque backshells 15 inch lbs

All Dimensions are for reference only
(Dimensions in brackets are in mm)

Options for Black Zinc Cobalt Plated	Ferrule	Max. Cable Diameter
001	Parallel Ferrule	5.6mm O.D.
002	Taper Ferrule	4.3mm O.D.
003	Taper Ferrule	3.2mm O.D.

For Crimp Tool details, please refer to the back of this catalogue.

**390-5012
Plug Dust Cap – Colour Black**

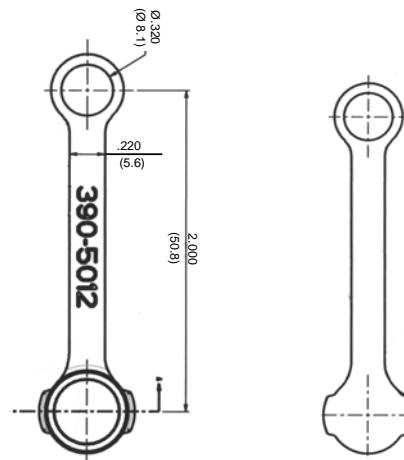
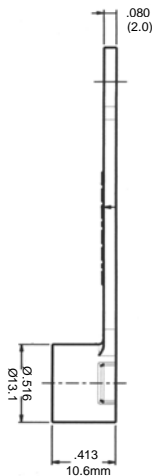

All Dimensions are for reference only
(Dimensions in brackets are in mm)

For use with PPS-06T and PPS-06TG Plugs and PPS-01T In Line Receptacles

We have selected Heatshrink Boots from Hellermann Tyton. Heatshrink Boots from other manufacturers may be used if appropriate.

100 Series – Bottle Shapes with Rib – MIL Style

This style is used in conjunction with the backshell (see page 8), providing strain relief and environmental sealing

Dimensions apply to all materials unless otherwise indicated and dimensions in brackets are in mm

Hellermann Part No	Expanded (Min)				Recovered (Max)		Recovered Dimensions Fully Shrunk					
	H	H -H matl	JØ	J -H matl	H	JØ	P ±10%	R ±10%	Jo ±10%	HW ±10%	JW ±10%	T ±10%
113-4-G-WM250	0.3976 (10.7)	0.3976 (10.7)	0.1811 (4.6)	0.1811 (4.6)	0.3110 (7.9)	(0.0787) (2.0)	1.0 (25.4)	0.5709 (14.5)	0.1811 (4.6)	0.0512 (1.3)	0.0512 (1.3)	0.0394 (1.0)

1100 Series – Right Angle Shapes with Rib – MIL Style

The style provides strain relief for harness systems when used in conjunction with the backshell (see page 8)

Dimensions apply to all materials unless otherwise indicated and dimensions in brackets are in mm

Hellermann Part No	Expanded (Min)		Recovered (Max)		Recovered Dimensions Fully Shrunk					
	H	JØ	H	JØ	P ±10%	R ±10%	S ±10%	Jo ±10%	W ±20%	T ±20%
1108-4-G-WM250	0.6496 (16.5)	0.6496 (16.5)	0.3110 (7.9)	0.1496 (3.8)	0.6875 (17.3)	0.7969 (20.1)	0.6005 (15.2)	0.1614 (4.1)	0.0394 (1.0)	0.0394 (1.0)

UP TO 7 WAY COILED SINGLE ENDED CABLE ASSEMBLY

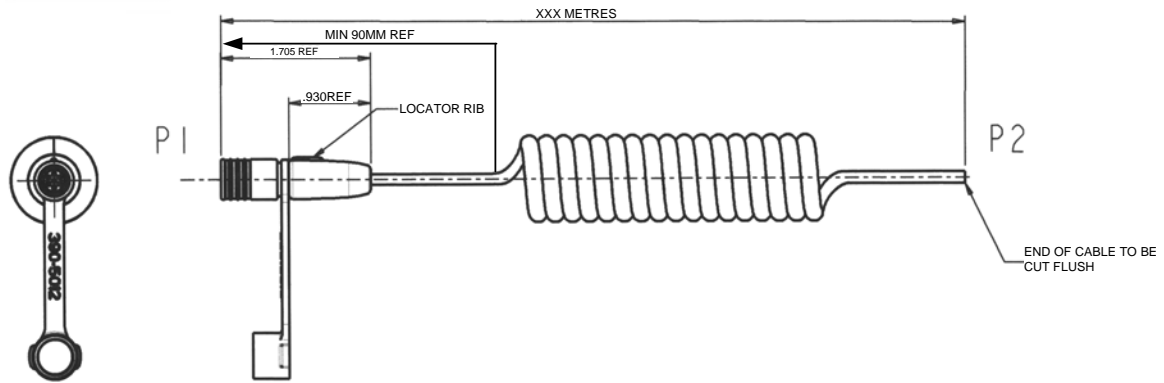

NOTES:

1. THE MAIN KEY OF THE CONNECTOR IS TO BE IN LINE WITH THE LOCATION RIB ON THE OVERMOULD
2. ALL DIMENSIONS ARE FOR REFERENCE ONLY
3. XXX IN PART NUMBER DENOTES CABLE LENGTH IN METRES

PPS - 5XXX - XXX
 CONNECTOR SERIES CABLE LENGTH
 TECHNICAL DESCRIPTION
 CONSULT PRODUCT SUPPORT
 PPS@AMPHENOL.CO.UK

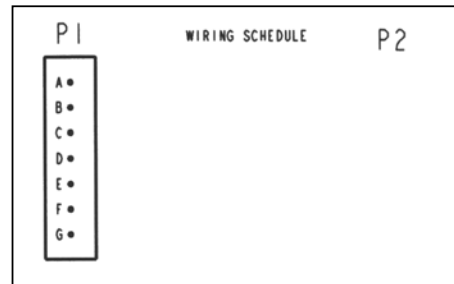

All Dimensions are for reference only
(Dimensions in brackets are in mm)

UP TO 7 WAY COILED DOUBLE ENDED CABLE ASSEMBLY

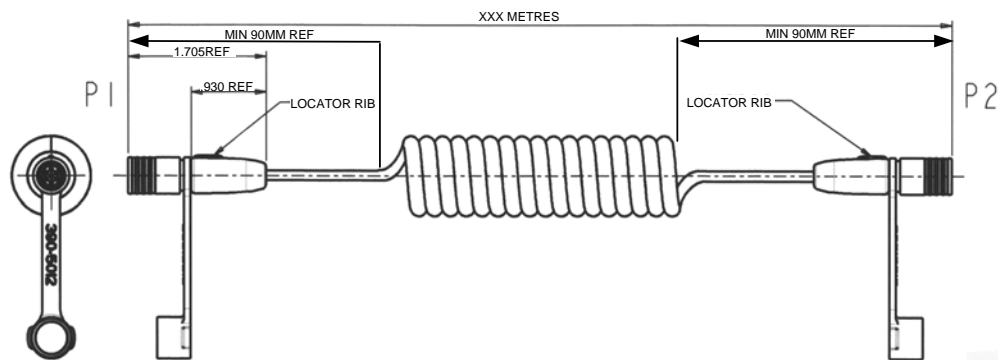

NOTES:

1. THE MAIN KEY OF THE CONNECTOR IS TO BE IN LINE WITH THE LOCATION RIB ON THE OVERMOULD
2. ALL DIMENSIONS ARE FOR REFERENCE ONLY
3. XXX IN PART NUMBER DENOTES CABLE LENGTH IN METRES

PPS - 5XXX - XXX
 CONNECTOR SERIES CABLE LENGTH
 TECHNICAL DESCRIPTION
 CONSULT PRODUCT SUPPORT
 PPS@AMPHENOL.CO.UK

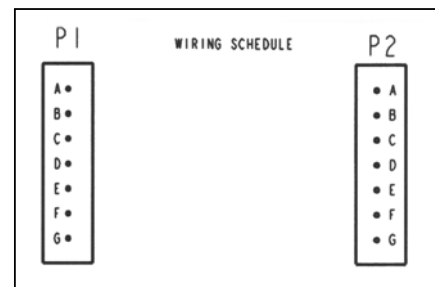

All Dimensions are for reference only
(Dimensions in brackets are in mm)

Any Cable Assembly Part Number will be issued at quotation or order placement stage by Amphenol Ltd only. For more details please consult the factory.

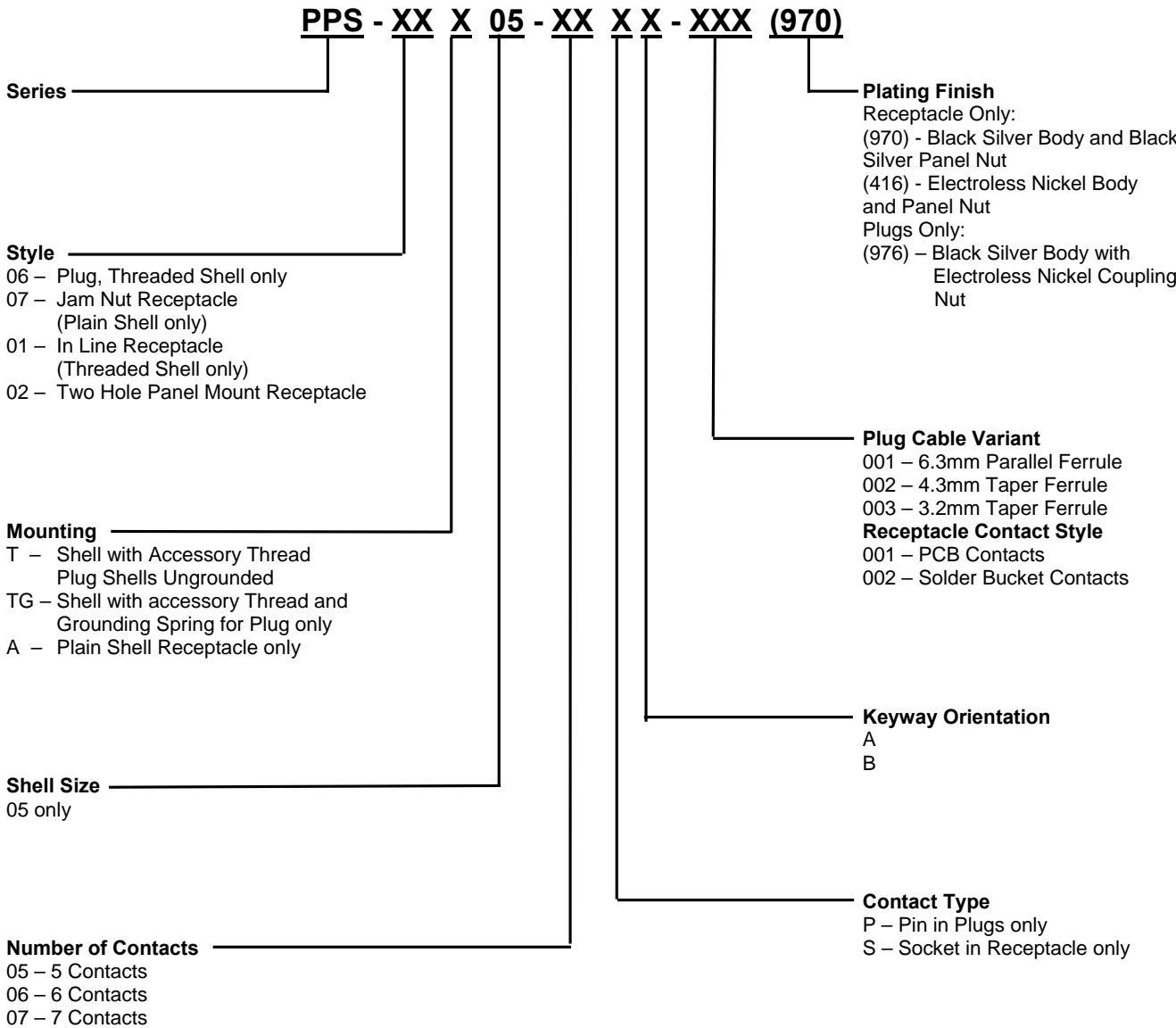

STANDARD PLATING

Plugs
 Omit Deviation – Black Silver Plated Body and Backshell with Black Coupling Nut

For Braid Termination Style 003

Crimp the Braid into place so that the ferrule butts up against the shoulder of the backshell. Use crimp tool Daniels HX4 M22520/5-01 handle, crimp die set Daniels Y530 CAGE 11851 at setting 180.



Notice: Products are sold subject to Amphenol's Standard Conditions of Sale. All specifications and statements contained herein are believed to be correct at the time of printing but no representation or warranty, express or implied, is given as to any specification or statement contained herein. Product specifications including performance characteristics are typical only and subject to deviation. Specifications are also subject to change without notice. Users should not assume that all safety measures are indicated or that other measures may not be required. No representation or warranty, express or implied, is given that any use of products (including any stated or suggested use) does not infringe any patent, registered design or other third party rights and no stated or suggested use of products can be taken to recommend any such infringement.

July 2006