

SynQor®

MCOTS-C-28-3R3-SM
Single Output
Sixteenth-brick

MILITARY COTS DC/DC CONVERTER

16-40V Continuous Input	16-50V Transient Input	3.3V Output	15A Output	83% @ 7.5A / 83% @ 15A Efficiency
-----------------------------------	----------------------------------	-----------------------	----------------------	---

Full Power Operation: -55°C to +100°C

The MilQor series of MIL-COTS DC/DC converters brings SynQor's field proven high-efficiency synchronous rectification technology to the Military/Aerospace industry. SynQor's ruggedized encased packaging approach ensures survivability in demanding environments. Compatible with the industry standard format, these converters operate at a fixed frequency, and follow conservative component derating guidelines. They are designed and manufactured to comply with a wide range of military standards.

Mil-COTS



Designed and Manufactured in the USA

Operational Features

- High efficiency, 83% at full rated load current
- Operating input voltage range: 16-40V
- Fixed frequency switching provides predictable EMI
- No minimum load requirement

Mechanical Features

- Industry standard sixteenth-brick pin-out configuration
- Size: 1.04" x 1.44" x 0.50"
(26.3 x 36.5 x 12.7 mm)
- Total weight: 1.14oz (32.3g)
- Flanged baseplate version available

Control Features

- On/Off control referenced to input return
- Remote sense for the output voltage
- Output voltage trim range of +10%, -10%

Safety Features

- 2250V, 30 MΩ input-to-output isolation
- Certified 60950-1 requirement for basic insulation (see Standards and Qualifications page)

Protection Features

- Input under-voltage lockout
- Output current limit and short circuit protection
- Active back bias limit
- Output over-voltage protection
- Thermal shutdown

Screening/Qualification

- AS9100 and ISO 9001:2000 certified facility
- Qualification consistent with MIL-STD-883
- Available with standard or military grade screening
- Pre-cap inspection per IPC-610, Class III
- Temperature cycling per MIL-STD-883, Method 1010, Condition B, 10 cycles
- Burn-In at 100C baseplate temperature
- Final visual inspection per MIL-STD-2008
- Full component traceability

BLOCK DIAGRAM

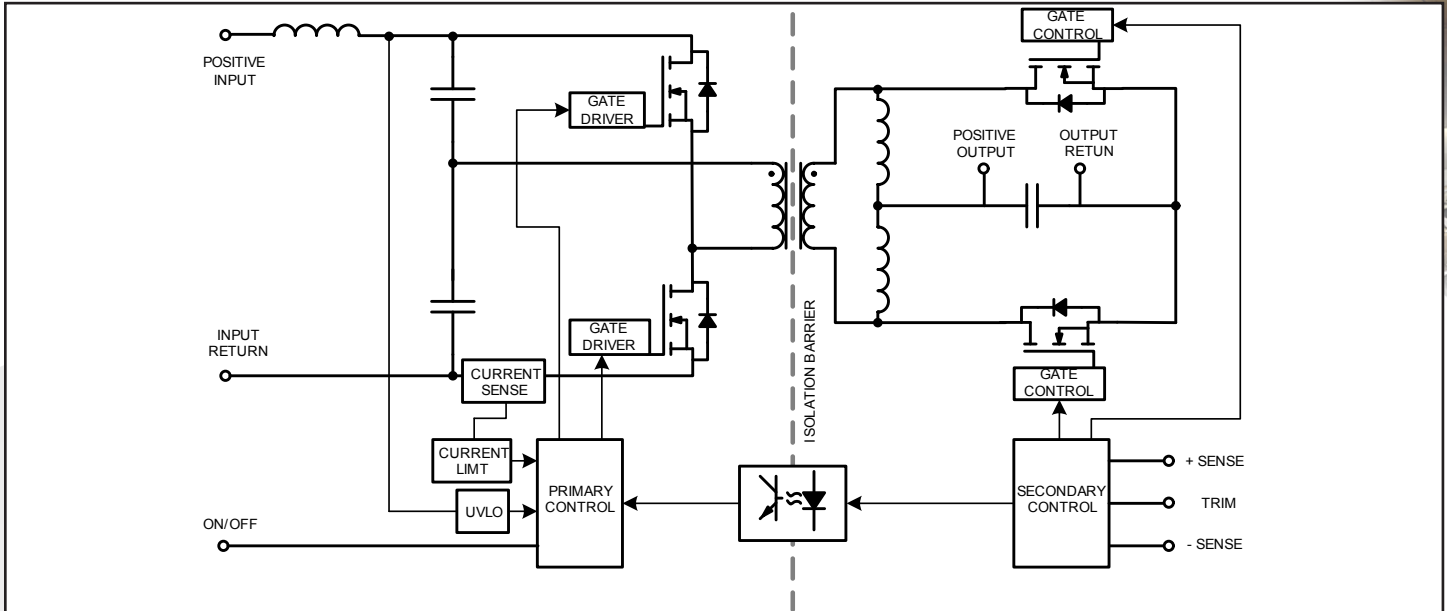

TYPICAL CONNECTION DIAGRAM

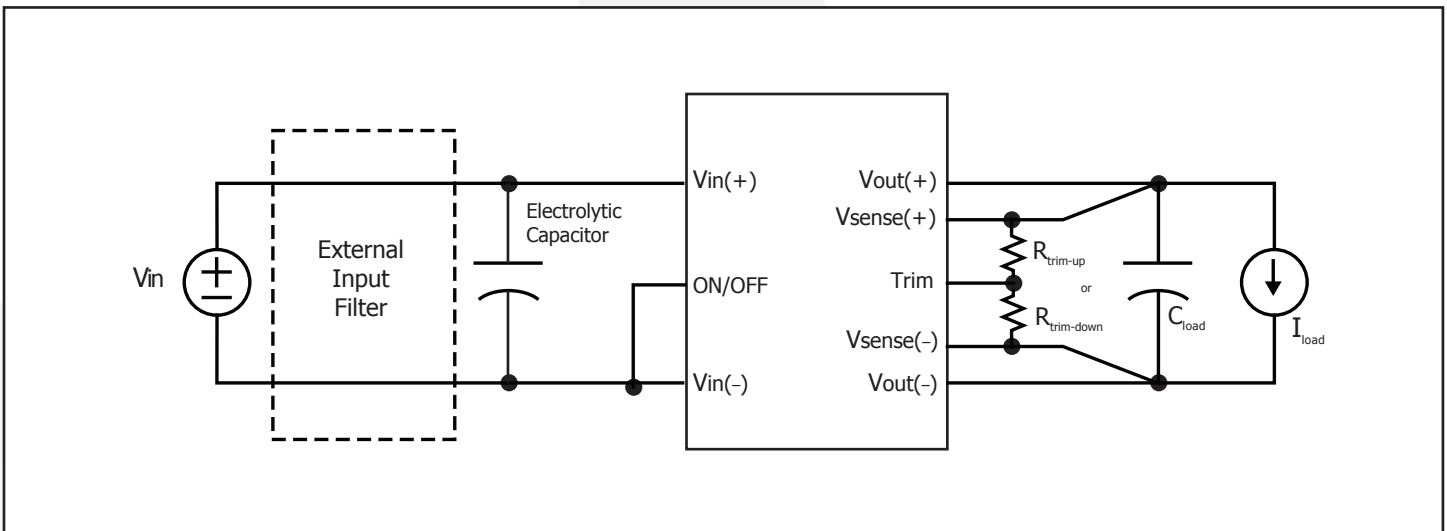



Technical Specification

MCOTS-C-28-3R3-SM

Output: 3.3V

Current: 15A

MCOTS-C-28-3R3-SM ELECTRICAL CHARACTERISTICS

Ta = 25 °C, Vin = 28 Vdc unless otherwise noted; full operating temperature range is -55 °C to +100 °C baseplate temperature with appropriate power derating. Specifications subject to change without notice.

Parameter	Min.	Typ.	Max.	Units	Notes & Conditions
ABSOLUTE MAXIMUM RATINGS					
Input Voltage					
Non-Operating			50	V	Continuous
Operating			40	V	Continuous
Operating Transient Protection			50	V	100 ms
Isolation Voltage					
Input to Output			2250	V dc	
Input to Base-Plate			2250	V dc	
Output to Base-Plate			2250	V dc	
Operating Temperature	-55		100	°C	Baseplate temperature
Storage Temperature	-65		135	°C	
Voltage at ON/OFF input pin	-2		8	V	
INPUT CHARACTERISTICS					
Operating Input Voltage Range	16	28	40	V	
Input Under-Voltage Lockout					
Turn-On Voltage Threshold	14.8	15.4	16.0	V	
Turn-Off Voltage Threshold	13.7	14.5	15.3	V	
Lockout Voltage Hysteresis		0.9		V	
Recommended External Input Capacitance		100		µF	Typical ESR 0.1-0.2 Ω
Input Filter Component Values (L\C)		0.47\5		µH\µF	Internal values; see Figure E
Maximum Input Current			5.5	A	Vin min; trim up; in current limit
No-Load Input Current		95	120	mA	
Disabled Input Current		10	14	mA	
Response to Input Transient		0.05		V	500 V/ms; see Figure 6
Input Terminal Ripple Current		135		mA	RMS
Recommended Input Fuse			20	A	Fast acting external fuse recommended
OUTPUT CHARACTERISTICS					
Output Voltage Set Point	3.267	3.3	3.333	V	
Output Voltage Regulation					
Over Line		±0.1	±0.3	%	
Over Load		±0.1	±0.3	%	
Over Temperature	-49.5		49.5	mV	
Total Output Voltage Range	3.218		3.383	V	Over sample, line, load, temperature & life
Output Voltage Ripple and Noise					20 MHz bandwidth; See Note 1
Peak-to-Peak	0	40	80	mV	Full load
RMS		10	20	mV	Full load
Operating Output Current Range	0		15	A	Subject to thermal derating
Output DC Current-Limit Inception	16.5	18	19.5	A	
Back-Drive Current Limit while Enabled		3		A	Negative current drawn from output
Back-Drive Current Limit while Disabled		2		mA	Negative current drawn from output
Maximum Output Capacitance			10000	µF	Vout nominal at full load (resistive); See Note 2
Output Voltage during Load Current Transient					
Step Change in Output Current (0.1 A/µs)		175		mV	50% to 75% to 50% Iout max
Settling Time		80		µs	To within 1% Vout nom
Output Voltage Trim Range	-10		10	%	Across Pins 8&4; Figure C; see Note 3
Output Voltage Remote Sense Range			10	%	Across Pins 8&4
Output Over-Voltage Protection	3.8	4.0	4.5	V	Over full temp range
EFFICIENCY					
100% Load		83		%	See Figure 1 for efficiency curve
50% Load		83		%	See Figure 1 for efficiency curve

Note 1: Output is terminated with 1 µF ceramic and 22 µF low-ESR tantalum capacitors. For applications requiring reduced output voltage ripple and noise, consult SynQor applications support (e-mail: mqnbofae@synqor.com)

Note 2: Recommended minimum output capacitance is 100 µF

Note 3: Trim-up range is limited below 10% at low line and full load. Contact SynQor applications support for more detail (e-mail: mqnbofae@synqor.com)



Technical Specification

MCOTS-C-28-3R3-SM

Output: 3.3V

Current: 15A

MCOTS-C-28-3R3-SM ELECTRICAL CHARACTERISTICS

Ta = 25 °C, Vin = 28 Vdc unless otherwise noted; full operating temperature range is -55 °C to +100 °C baseplate temperature with appropriate power derating. Specifications subject to change without notice.

Parameter	Min.	Typ.	Max.	Units	Notes & Conditions
DYNAMIC CHARACTERISTICS					
Turn-On Transient					
Turn-On Time		35		ms	Full load, Vout=90% nom.
Start-Up Inhibit Time	180	200	250	ms	Figure F; See Note 1
Power-up Inhibit Time		2		ms	Figure F
Output Voltage Overshoot		0		%	Maximum Output Capacitance
ISOLATION CHARACTERISTICS					
Isolation Voltage (dielectric strength)					See Absolute Maximum Ratings
Isolation Resistance		30		MΩ	
Isolation Capacitance (input to output)		1000		pF	See Note 2
TEMPERATURE LIMITS FOR POWER DERATING CURVES					
Semiconductor Junction Temperature			125	°C	Package rated to 150 °C
Board Temperature			125	°C	UL rated max operating temp 130 °C
Transformer Temperature			125	°C	
Maximum Baseplate Temperature, Tb			100	°C	
FEATURE CHARACTERISTICS					
Switching Frequency		350		kHz	Isolation stage switching freq. is half this
ON/OFF CONTROL					
Off-State Voltage	2.4		8	V	
On-State Voltage	-2		0.8		
ON/OFF CONTROL					
Pull-Up Voltage		5		V	Application notes Figures A & B
Pull-Up Resistance		10		kΩ	
Over-Temperature Shutdown OTP Trip Point		125		°C	Average PCB Temperature
Over-Temperature Shutdown Restart Hysteresis		10		°C	
RELIABILITY CHARACTERISTICS					
Calculated MTBF (Telcordia) TR-NWT-000332		TBD		10 ⁶ Hrs.	80% load, 200LFM, 40 °C Ta
Calculated MTBF (MIL-217) MIL-HDBK-217F		TBD		10 ⁶ Hrs.	80% load, 200LFM, 40 °C Ta
Field Demonstrated MTBF		TBD		10 ⁶ Hrs.	

Note 1: Maximum value is 400ms for DC current limit and short circuit fault conditions

Note 2: Higher values of isolation capacitance can be added external to the module

STANDARDS COMPLIANCE

Parameter	Notes & Conditions
STANDARDS COMPLIANCE	
UL 60950-1:2003	Basic Insulation
CAN/CSA-C22.2 No. 60950-1:2003	
EN60950-1:2001	

Note: An external input fuse must always be used to meet these safety requirements. Contact SynQor for official safety certificates on new releases or download from the SynQor website.

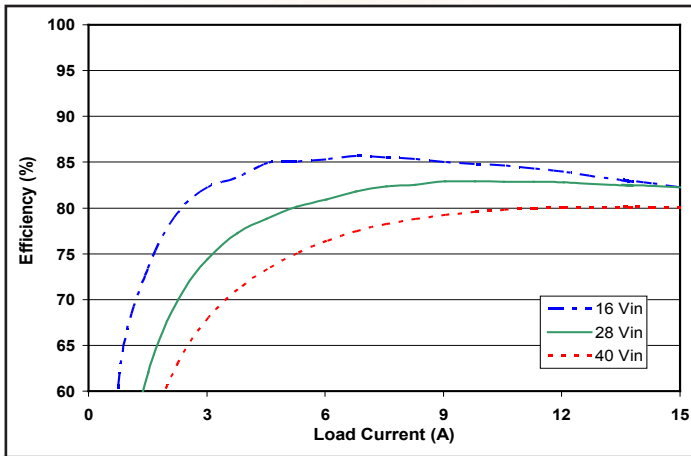

Figure 1: Efficiency at nominal output voltage vs. load current for minimum, nominal, and maximum input voltage at 25°C.

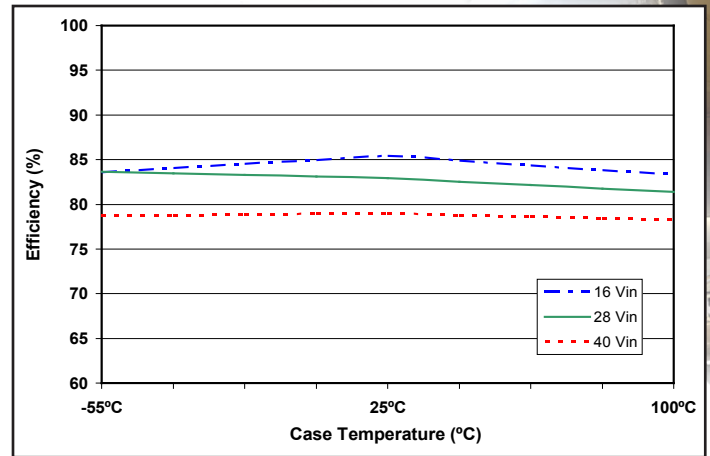

Figure 2: Efficiency at nominal output voltage and 60% rated power vs. case temperature for minimum, nominal, and maximum input voltage.

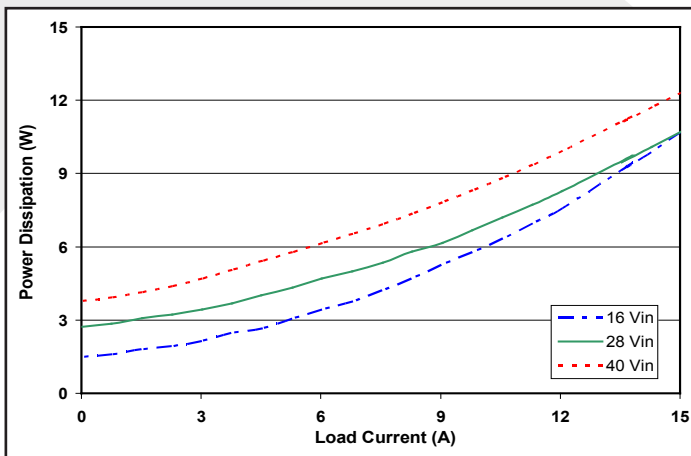

Figure 3: Power dissipation at nominal output voltage vs. load current for minimum, nominal, and maximum input voltage at $T_{CASE}=25^{\circ}C$.

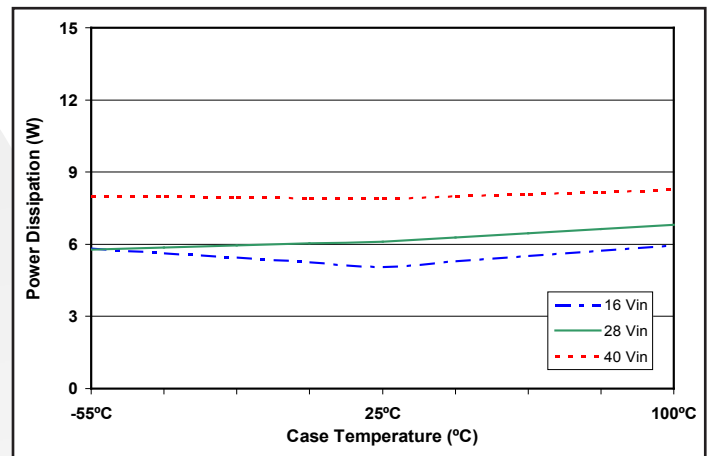

Figure 4: Power dissipation at nominal output voltage and 60% rated power vs. case temperature for minimum, nominal, and maximum input voltage.

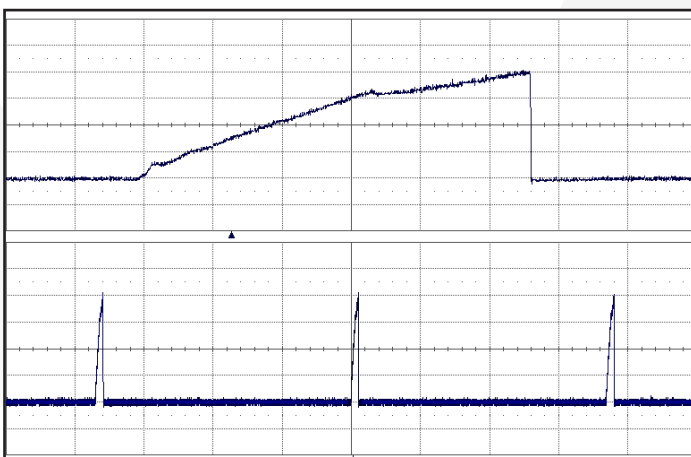

Figure 5: Load current (5A/div) as a function of time (2ms/div and 100ms/div) when the converter attempts to turn on into a 10 mΩ short circuit.

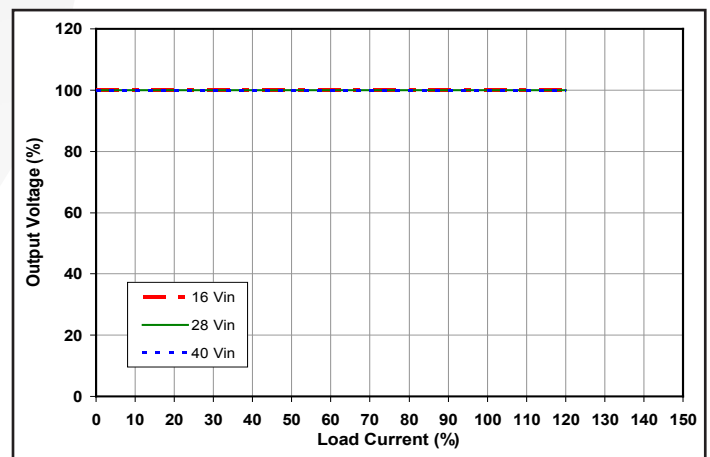

Figure 6: Output voltage vs. load current showing typical current limit curves. See Current Limit section in the Application Notes.

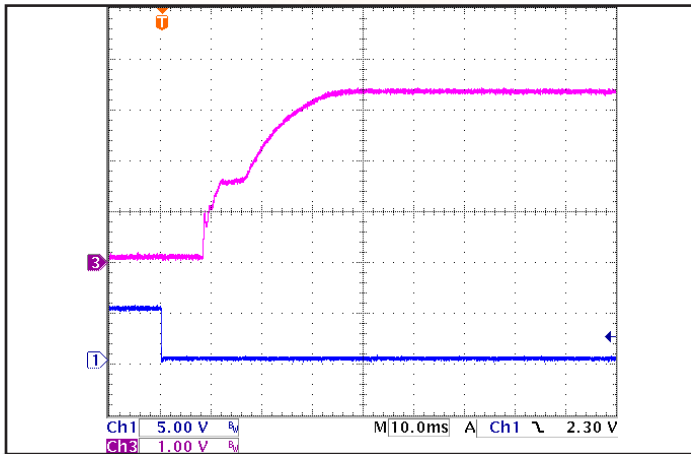

Figure 7: Typical startup waveform. Input voltage pre-applied, ON/OFF Pin on Ch 1.

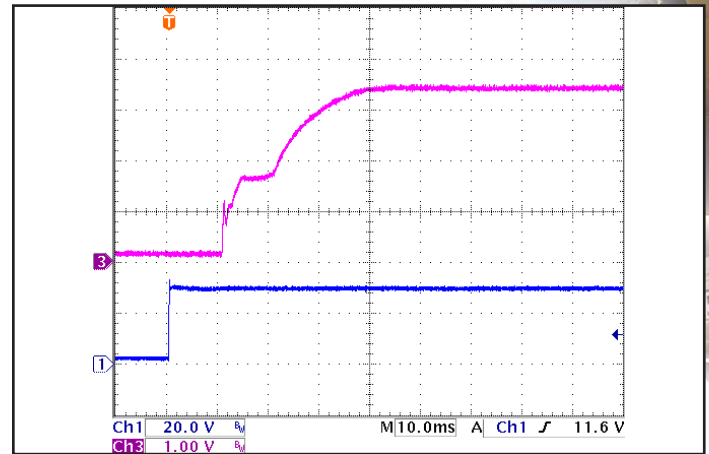

Figure 8: Turn-on transient at full resistive load and zero output capacitance initiated by Vin. ENA1 and ENA2 both previously high. Ch 1: Vout (20V/div). Ch 3: Vin (1V/div).

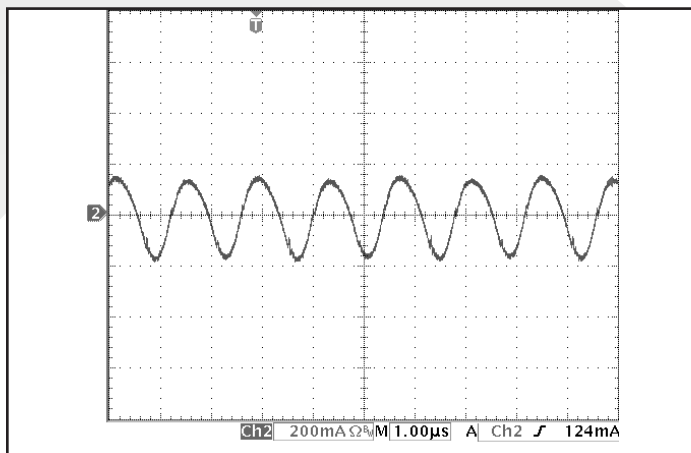

Figure 9: Input terminal current ripple, i_C , at full rated output current and nominal input voltage with SynQor MCOTS filter module (200 mA/div). Bandwidth: 20MHz. See Figure 17.

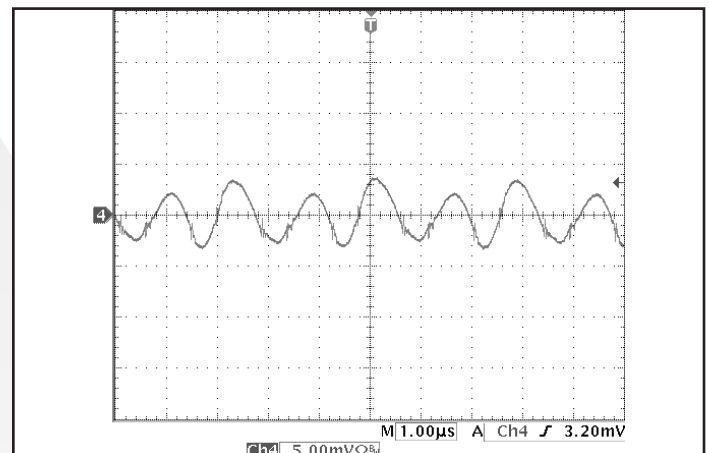

Figure 10: Output voltage ripple, Vout, at nominal input voltage and rated load current (5 mV/div). Load capacitance: 1µF ceramic capacitor and 10µF tantalum capacitor. Bandwidth: 10 MHz. See Figure 17.

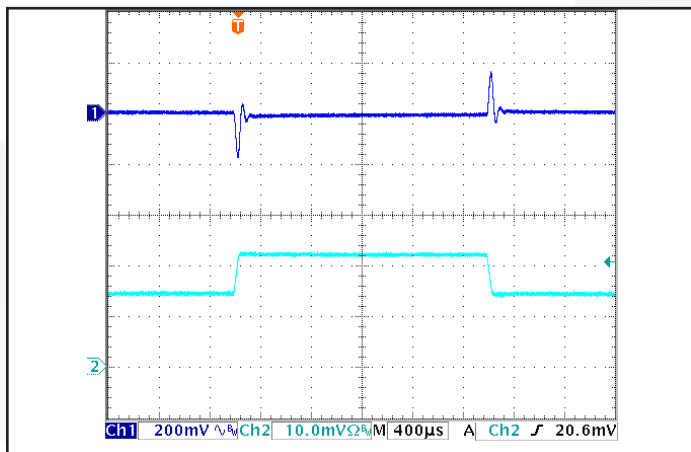

Figure 11: Output voltage response to step-change in load current (50%-75%-50% of $I_{out(max)}$; $dI/dt = 0.1 A/\mu s$). Load cap: 1 µF ceramic and 15 µF tantalum capacitors. Ch 1: Vout (200mV/div), Ch 2: Iout (5A/div).

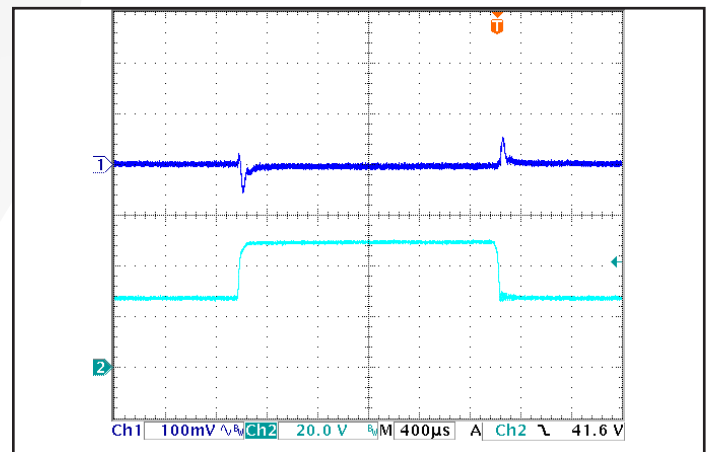

Figure 12: Output voltage response to step-change in input voltage (250V/ms). Load cap: 100 µF electrolytic output capacitance. Ch 1: Vout (100mV/div), Ch 2: Vin (20V/div).

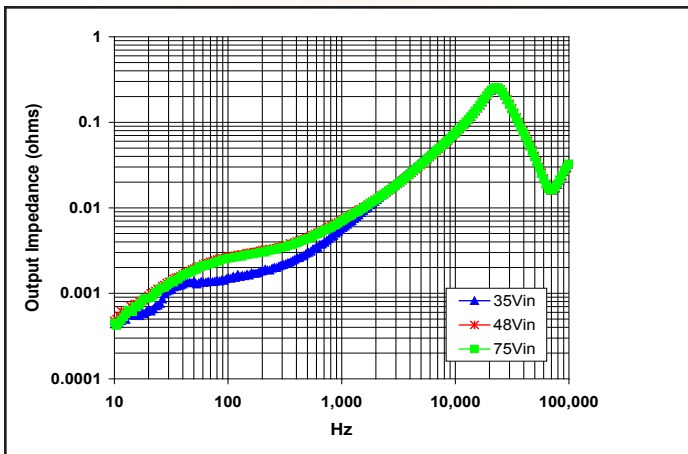

Figure 13: Magnitude of incremental output impedance ($Z_{out} = v_{out}/i_{out}$) for minimum, nominal, and maximum input voltage at full rated power.

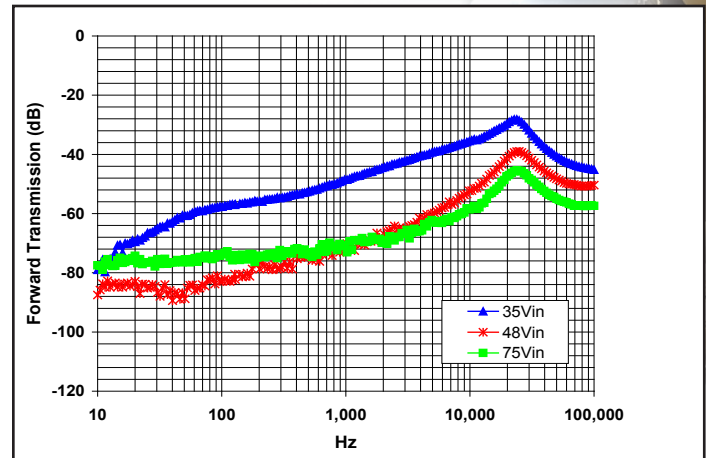

Figure 14: Magnitude of incremental forward transmission ($FT = v_{out}/v_{in}$) for minimum, nominal, and maximum input voltage at full rated power.

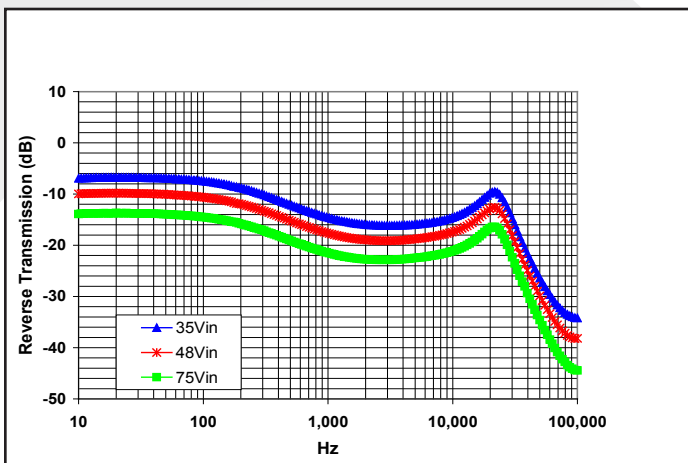

Figure 15: Magnitude of incremental reverse transmission ($RT = i_{in}/i_{out}$) for minimum, nominal, and maximum input voltage at full rated power.

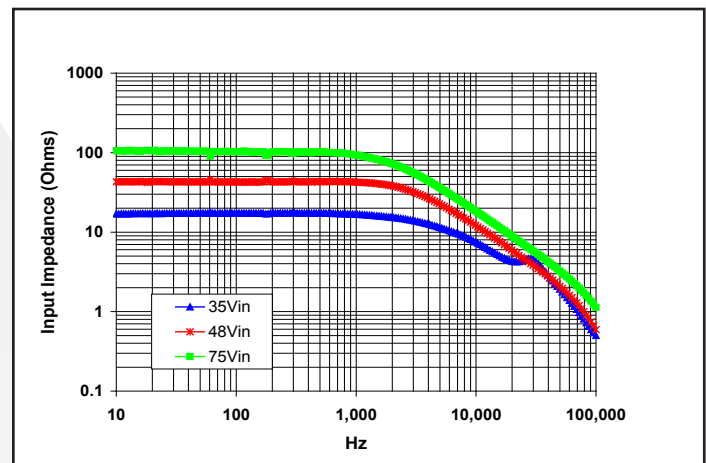

Figure 16: Magnitude of incremental input impedance ($Z_{in} = v_{in}/i_{in}$) for minimum, nominal, and maximum input voltage at full rated power.

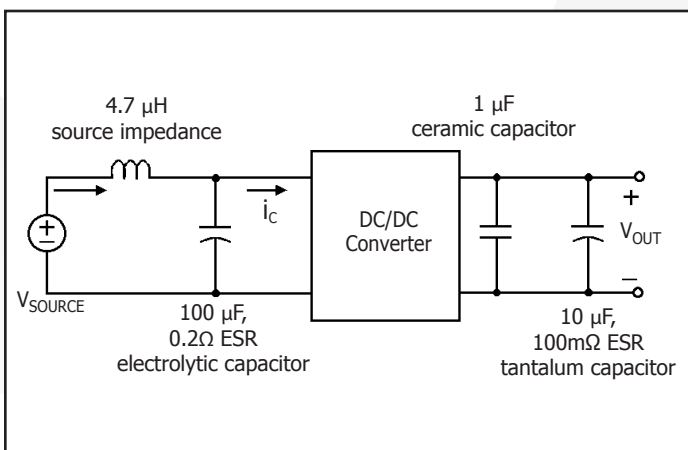

Figure 17: Test set-up diagram showing measurement points for Input Terminal Ripple Current (Figure 9) and Output Voltage Ripple (Figure 10).

BASIC OPERATION AND FEATURES

This converter switches at a fixed frequency for predictable EMI performance. Rectification of the transformer's output is accomplished with synchronous rectifiers. These devices, which are MOSFETs with a very low on-state resistance, dissipate far less energy than Schottky diodes. This is the primary reason that the converter has such high efficiency, even at very low output voltages and very high output currents.

These converters are offered totally encased to withstand harsh environments and thermally demanding applications. Dissipation throughout the converter is so low that it does not require a heatsink for operation in many applications; however, adding a heatsink provides improved thermal derating performance in extreme situations.

This series of converters use the industry standard footprint and pin-out configuration.

CONTROL FEATURES

REMOTE ON/OFF (Pin 2): The ON/OFF input, Pin 2, permits the user to control when the converter is on or off. This input is referenced to the return terminal of the input bus, Vin(-). The ON/OFF signal is active low (meaning that a low turns the converter on). Figure A details four possible circuits for driving the ON/OFF pin. Figure B is a detailed look of the internal ON/OFF circuitry.

REMOTE SENSE(±) (Pins 7 and 5): The SENSE(±) inputs correct for voltage drops along the conductors that connect the converter's output pins to the load.

Pin 7 should be connected to Vout(+) and Pin 5 should be connected to Vout(-) at the point on the board where regulation is desired. A remote connection at the load can adjust for a voltage drop only as large as that specified in this datasheet, that is

$$[V_{out(+)} - V_{out(-)}] - [V_{sense(+)} - V_{sense(-)}] \leq \text{Sense Range \%} \times V_{out}$$

Pins 7 and 5 must be connected for proper regulation of the output voltage. If these connections are not made, the converter will deliver an output voltage that is slightly higher than its specified value.

Note: the output over-voltage protection circuit senses the voltage across the output (pins 8 and 4) to determine when it should trigger, not the voltage across the converter's sense leads (pins 7 and 5). Therefore, the resistive drop on the board should be small enough so that output OVP does not trigger, even during load transients.

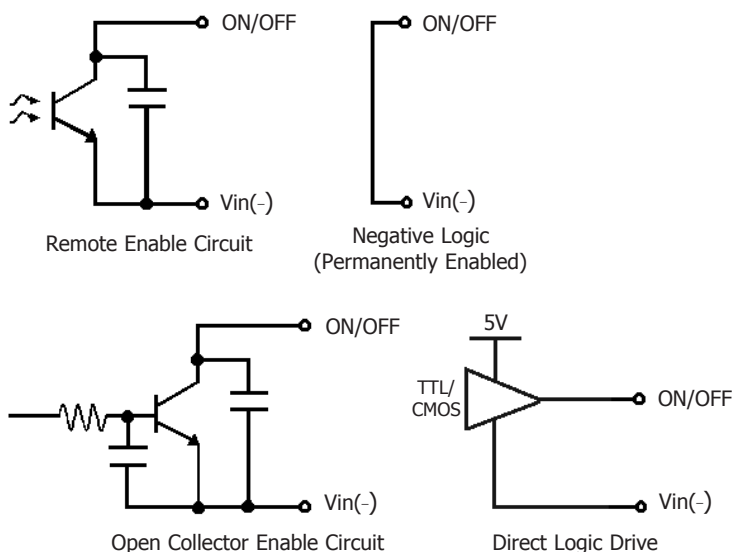

Figure A: Various circuits for driving the ON/OFF pin.

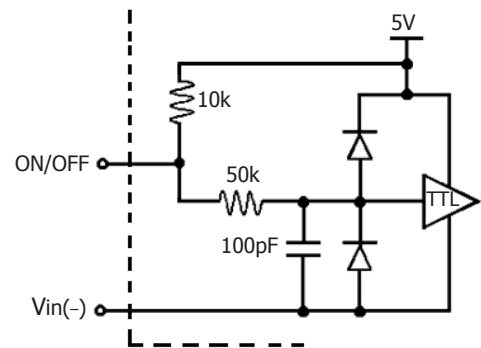

Figure B: Internal ON/OFF pin circuitry

OUTPUT VOLTAGE TRIM (Pin 6): The TRIM input permits the user to adjust the output voltage across the sense leads up or down according to the trim range specifications.

To decrease the output voltage, the user should connect a resistor between Pin 6 and Pin 5 (SENSE(-) input). For a desired decrease of the nominal output voltage, the value of the resistor should be

$$R_{\text{trim-down}} = \left(\frac{511}{\Delta\%} \right) - 10.22 \text{ (k}\Omega\text{)}$$

where

$$\Delta\% = \left| \frac{V_{\text{nominal}} - V_{\text{desired}}}{V_{\text{nominal}}} \right| \times 100\%$$

To increase the output voltage, the user should connect a resistor between Pin 6 and Pin 7 (SENSE(+) input). For a desired increase of the nominal output voltage, the value of the resistor should be

$$R_{\text{trim-up}} = \left(\frac{5.11V_{\text{out}} \times (100 + \Delta\%)}{1.225\Delta\%} - \frac{511}{\Delta\%} - 10.22 \right) \text{ (k}\Omega\text{)}$$

where V_{out} = Nominal Output Voltage

Trim graphs show the relationship between the trim resistor value and $R_{\text{trim-up}}$ and $R_{\text{trim-down}}$, showing the total range the output voltage can be trimmed up or down.

Note: the TRIM feature does not affect the voltage at which the output over-voltage protection circuit is triggered. Trimming the output voltage too high may cause the over-voltage protection circuit to engage, particularly during transients.

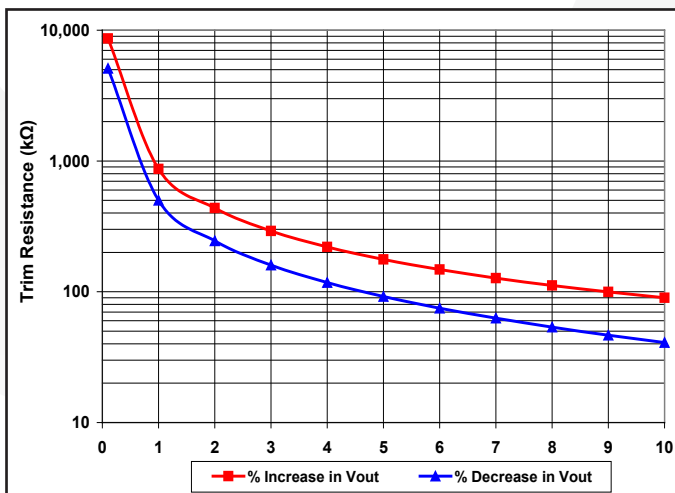

Figure C: Trim graph for trim-up, trim down.

It is not necessary for the user to add capacitance at the Trim pin. The node is internally bypassed to eliminate noise.

Total DC Variation of V_{out} : For the converter to meet its full specifications, the maximum variation of the dc value of V_{out} , due to both trimming and remote load voltage drops, should not be greater than that specified for the output voltage trim range.

PROTECTION FEATURES

Input Under-Voltage Lockout: The converter is designed to turn off when the input voltage is too low, helping avoid an input system instability problem, described in more detail in the application note titled "Input System Instability" on our website. The lockout circuitry is a comparator with dc hysteresis. When the input voltage is rising, it must exceed the typical Turn-On Voltage Threshold value (listed on the specifications page) before the converter will turn on. Once the converter is on, the input voltage must fall below the typical Turn-Off Voltage Threshold value before the converter will turn off.

Output Current Limit: If the output current exceeds the Output Current Limit threshold, the converter turns off. The converter then enters a 'hiccup mode' where it repeatedly turns on and off with a 350ms (typical) off time at small duty cycle until the short circuit condition is removed. This prevents excessive heating of the converter or the load board.

Output Over-Voltage Limit: If the voltage across the output pins exceeds the Output Over-Voltage Protection threshold, the converter will immediately stop switching. This prevents damage to the load circuit due to 1) excessive series resistance in output current path from converter output pins to sense point, 2) a release of a short-circuit condition, or 3) a release of a current limit condition. Load capacitance determines exactly how high the output voltage will rise in response to these conditions. After 200 ms the converter will automatically restart.

Over-Temperature Shutdown: A temperature sensor on the converter senses the average temperature of the module. The thermal shutdown circuit is designed to turn the converter off when the temperature at the sensed location reaches the Over-Temperature Shutdown value. It will allow the converter to turn on again when the temperature of the sensed location falls by the amount of the Over-Temperature Shutdown Restart Hysteresis value.

APPLICATION CONSIDERATIONS

Input System Instability: This condition can occur because any dc-dc converter appears incrementally as a negative resistance load. A detailed application note titled "Input System Instability" is available on the SynQor website which provides an understanding of why this instability arises, and shows the preferred solution for correcting it.

Application Circuits: Figure D provides a typical circuit diagram which details the input filtering and voltage trimming.

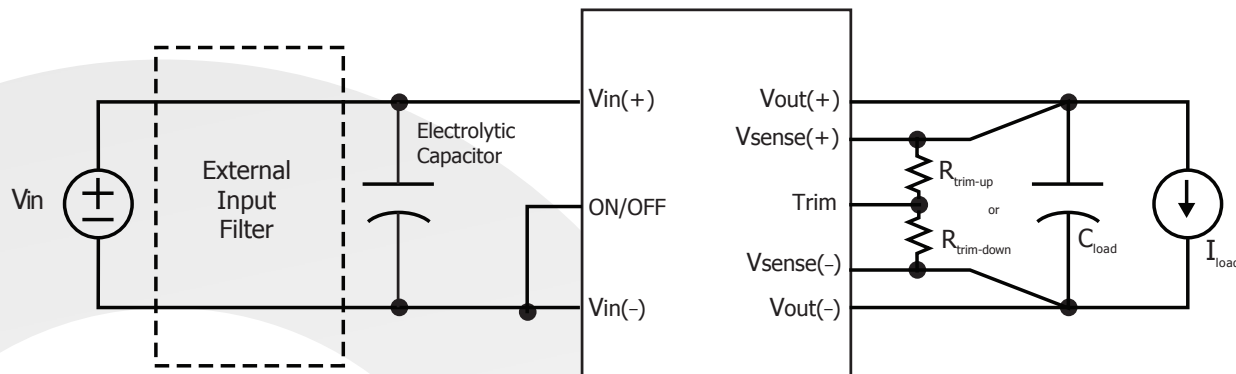

Figure D: Typical application circuit (negative logic unit, permanently enabled).

Input Filtering and External Capacitance: Figure E provides a diagram showing the internal input filter components. This filter dramatically reduces input terminal ripple current, which otherwise could exceed the rating of the converter's external electrolytic input capacitor. The recommended external input capacitance

is specified in the Input Characteristics section on the Electrical Characteristics page. More detailed information is available in the application note titled "EMI Characteristics" on the SynQor website.

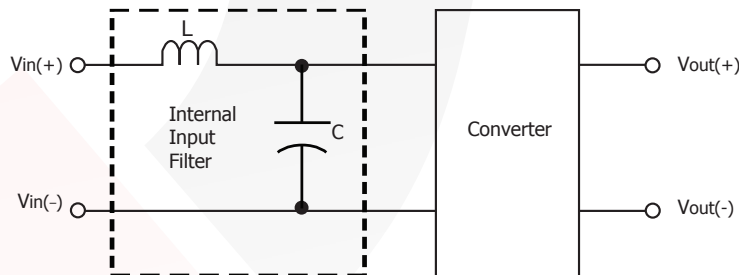

Figure E: Internal Input Filter Diagram

Startup Inhibit Period: The Startup Inhibit Period ensures that the converter will remain off for approximately 200 ms when it is shut down for any reason. When an output short is present, this generates a "hiccup mode," which prevents the converter from overheating. In all, there are six ways that the converter can be shut down, initiating a Startup Inhibit Period:

- Input Under-Voltage Lockout
- Output Over-Voltage Protection
- Over Temperature Shutdown
- Current Limit
- Short Circuit Protection
- Turned off by the ON/OFF input

Figure F shows three turn-on scenarios, where a Startup Inhibit Period is initiated at t_0 , t_1 , and t_2 :

Before time t_0 , when the input voltage is below the UVL threshold, the unit is disabled by the Input Under-Voltage Lockout feature. When the input voltage rises above the UVL threshold, the Input Under-Voltage Lockout is released, and a Startup Inhibit Period is initiated. At the end of this delay, the ON/OFF pin is evaluated, and since it is active, the unit turns on.

At time t_1 , the unit is disabled by the ON/OFF pin, and it cannot be enabled again until the Startup Inhibit Period has elapsed.

When the ON/OFF pin goes high after t_2 , the Startup Inhibit Period

has elapsed, and the output turns on within the typical Turn-On Time.

Thermal Considerations: The maximum operating base-plate temperature, T_{BP} , is 100 °C. As long as the user's thermal system keeps $T_B \leq 100$ °C, the converter can deliver its full rated power.

A power derating curve can be calculated for any heatsink that is attached to the base-plate of the converter. It is only necessary to determine the thermal resistance, $R_{TH_{BA}}$, of the chosen heatsink between the base-plate and the ambient air for a given airflow rate. This information is usually available from the heatsink vendor. The following formula can be used to determine the maximum power the converter can dissipate for a given thermal condition if its base-plate is to be no higher than 100 °C.

$$P_{diss}^{max} = \frac{100 \text{ }^\circ\text{C} - T_A}{R_{TH_{BA}}}$$

This value of power dissipation can then be used in conjunction with the data shown in Figure 2 to determine the maximum load current (and power) that the converter can deliver in the given thermal condition.

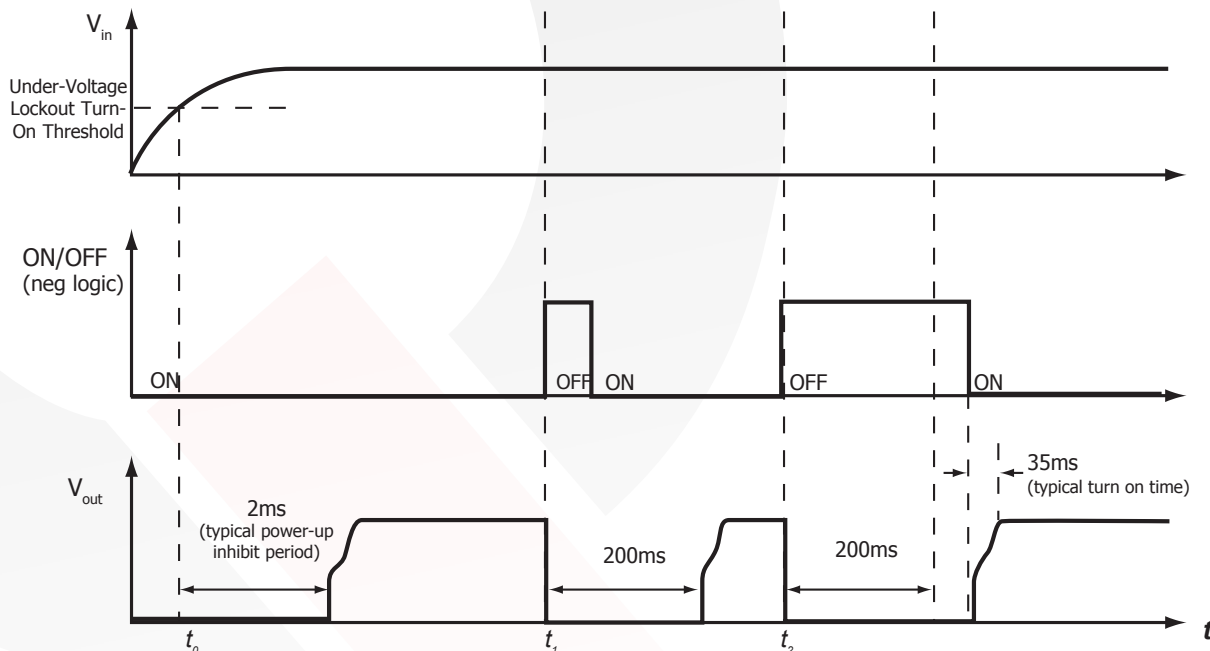
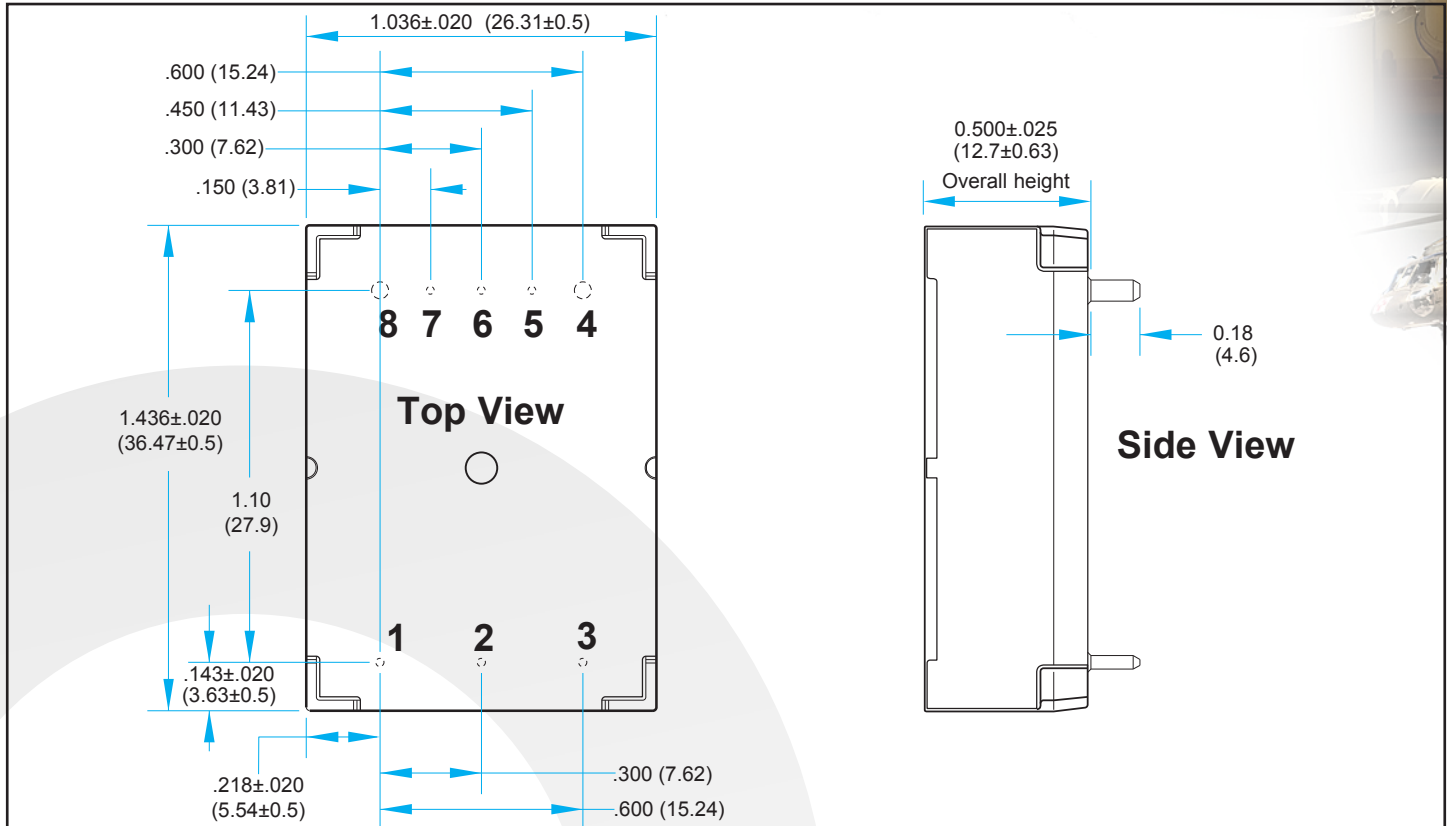

Figure F: Startup Inhibit Period (turn-on time not to scale)

Mechanical Drawing – Normal Heatsink Option



NOTES

- 1) Baseplate flatness tolerance is 0.004" (.10mm) TIR for surface.
- 2) Pins 1-3, 5-7 are 0.040" (1.02mm) diameter, with 0.080" (2.03mm) diameter standoff shoulders.
- 3) Pins 4 and 8 are 0.062" (1.57 mm) diameter with 0.100" (2.54 mm) diameter standoff shoulders.
- 4) All Pins: Material – Copper Alloy; Finish – Matte Tin over Nickel plate
- 5) Undimensioned components are shown for visual reference only.
- 6) Weight: 1.14oz (32.3g) typical
- 7) All dimensions in inches (mm)
Tolerances: x.xx +/-0.02 in. (x.x +/-0.5mm)
x.xxx +/-0.010 in. (x.xx +/-0.25mm)
- 8) Workmanship: Meets or exceeds IPC-A610 Class II
- 9) Recommended pin length is 0.03" (0.76mm) greater than the PCB thickness.

PIN DESIGNATIONS

Pin	Name	Function
1	Vin(+)	Positive input voltage
2	ON/OFF	TTL input to turn converter on and off, referenced to Vin(-), with internal pull up.
3	Vin(-)	Negative input voltage
4	Vout(-)	Negative output voltage
5	SENSE(-)	Negative remote sense ¹
6	TRIM	Output voltage trim ²
7	SENSE(+)	Positive remote sense ³
8	Vout(+)	Positive output voltage

Notes:

- 1) SENSE(-) should be connected to Vout(-) either remotely or at the converter.
- 2) Leave TRIM pin open for nominal output voltage.
- 3) SENSE(+) should be connected to Vout(+) either remotely or at the converter.

Mechanical Drawing – Flanged Heatsink Option

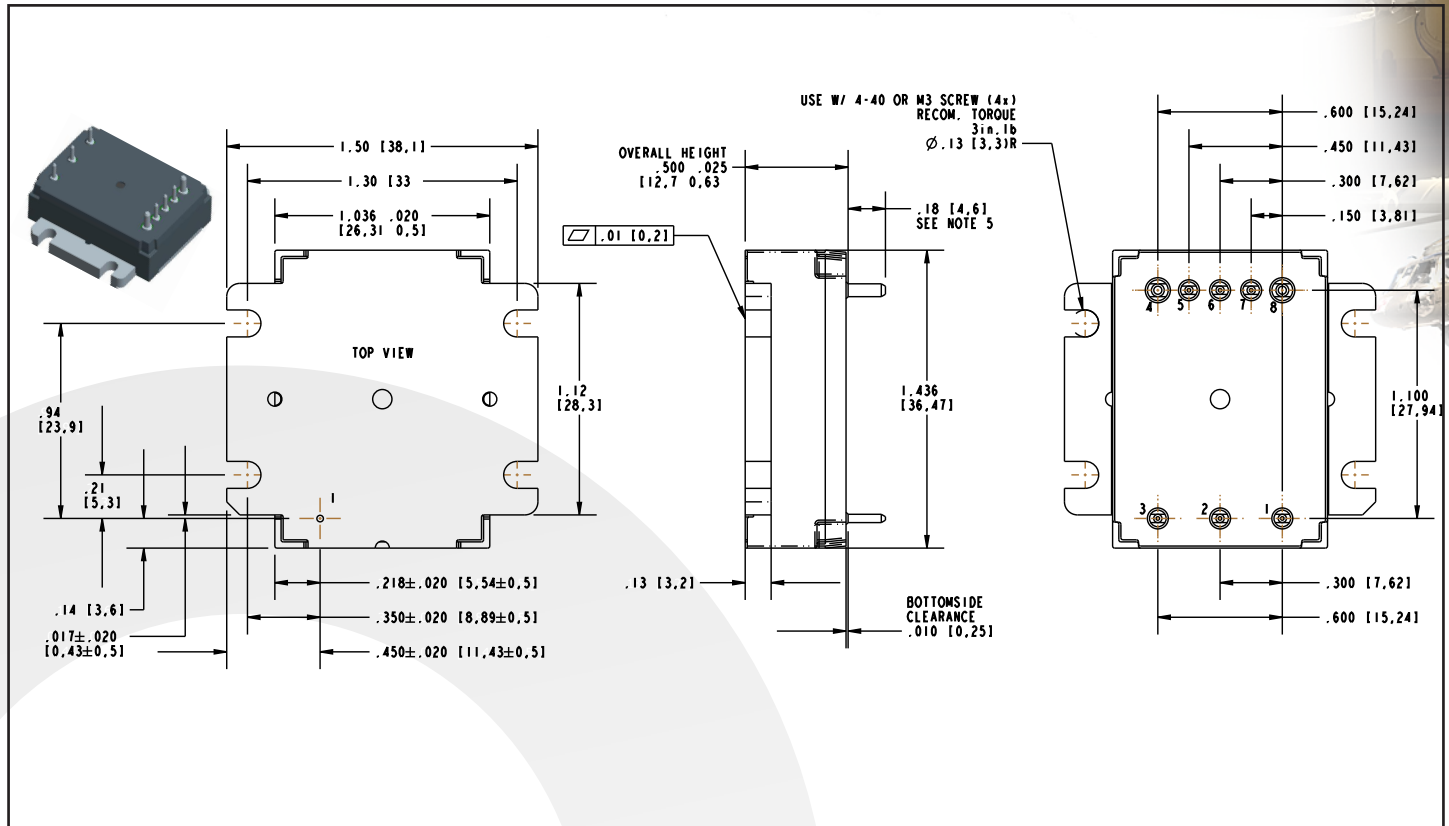

NOTES

- 1) Applied torque per screw should not exceed 5in-lb (3in-lb recommended).
- 2) Baseplate flatness tolerance is 0.01" (.25mm) TIR for surface.
- 3) Pins 1-3, 5-7 are 0.040" (1.02mm) diameter, with 0.080" (2.03mm) diameter standoff shoulders.
- 4) Pins 4 and 8 are 0.062" (1.57 mm) diameter with 0.100" (2.54 mm) diameter standoff shoulders.
- 5) All Pins: Material – Copper Alloy; Finish – Matte Tin over Nickel plate
- 6) Weight: 1.22 oz (34.6g) typical
- 7) Undimensioned components are shown for visual reference only.
- 8) All dimensions in inches (mm)
Tolerances: x.xx +/-0.02 in. (x.x +/-0.5mm)
x.xxx +/-0.010 in. (x.xx +/-0.25mm)
- 9) Workmanship: Meets or exceeds IPC-A610 Class II
- 10) Recommended pin length is 0.03" (0.76mm) greater than the PCB thickness.
- 11) A thermal interface material is required to assure proper heat transfer from the flanged baseplate to the cooling surface. Thermal grease, conductive pads, compounds, and other similar products are available from many heatsink manufacturers.

PIN DESIGNATIONS

Pin	Name	Function
1	Vin(+)	Positive input voltage
2	ON/OFF	TTL input to turn converter on and off, referenced to Vin(-), with internal pull up.
3	Vin(-)	Negative input voltage
4	Vout(-)	Negative output voltage
5	SENSE(-)	Negative remote sense ¹
6	TRIM	Output voltage trim ²
7	SENSE(+)	Positive remote sense ³
8	Vout(+)	Positive output voltage

Notes:

- 1) SENSE(-) should be connected to Vout(-) either remotely or at the converter.
- 2) Leave TRIM pin open for nominal output voltage.
- 3) SENSE(+) should be connected to Vout(+) either remotely or at the converter.

MIL-COTS Qualification

Test Name	Details	# Tested (# Failed)	Consistent with MIL-STD-883F Method	Consistent with MIL-STD-883F Method 5005
Life Testing	Visual, mechanical and electrical testing before, during and after 1000 hour burn-in @ full load	15 (0)	Method 1005.8	
Shock-Vibration	Visual, mechanical and electrical testing before, during and after shock and vibration tests	5 (0)		MIL-STD-202, Method 1
Humidity	+85°C, 85% RH, 1000 hours, 2 minutes on/6 hours off	8 (0)	Method 1004.7	
Temperature Cycling	500 cycles of -55°C to +100°C (30 minute dwell at each temperature)	10 (0)	Method 1010.8	Condition A
Solderability	15 pins	15 (0)	Method 2003	
DMT	-65°C to +110°C across full line and load specifications in 5°C steps	7 (0)		

MIL-COTS Screening

Screening	Process Description	Standard	Military (MIL Grade)
Baseplate Operating Temperature		-55°C to +100°C	-55°C to +100°C
Storage Temperature		-65°C to +135°C	-65°C to +135°C
Pre-Cap Inspection	IPC-610, Class III	●	●
Temperature Cycling	Method 1010, Condition B, 10 Cycles		●
Burn-In	100°C Baseplate	12 Hours	96 Hours
Final Electrical Test	100%	25°C	-55°C, +25°C, +100°C
Final Visual Inspection	MIL-STD-2008	●	●



Technical Specification

MCOTS-C-28-3R3-SM

Output: 3.3V

Current: 15A

Ordering Information/ Part Numbering

Family	Product	Input Voltage	Output Voltage	Package	Heatsink Option	Screening Level
MCOTS	C: Converter F: Filter	28: 16-40V 48: 34-75V 270: 155-425V	1R2: 1.2V 15: 15V 1R5: 1.5V 24: 24V 1R8: 1.8V 28: 28V 2R5: 2.5V 40: 40V 3R3: 3.3V 48: 48V 05: 5V 50: 50V 07: 7V P: Passive 12: 12V T: Active	FT: Full Brick HP: Half Brick Peta HZ: Half Brick Zeta QT: Quarter Brick EG: Eighth Brick SM: Sixteenth Brick	N: Normal F: Flanged	S: Standard M: M-Grade

Example MCOTS-C-28-3R3-SM-N-S

APPLICATION NOTES

A variety of application notes and technical white papers can be downloaded in pdf format from our [website](#).

PATENTS

SynQor holds the following U.S. patents, one or more of which apply to each product listed in this brochure. Additional patent applications may be pending or filed in the future.

5,999,417	6,222,742	6,545,890	6,577,109	6,594,159
6,731,520	6,894,468	6,896,526	6,927,987	7,050,309
7,072,190	7,085,146	7,119,524	7,269,034	7,272,021
7,272,023	7,558,083	7,564,702		

Contact SynQor for further information:

Phone: 978-849-0600
Toll Free: 888-567-9596
Fax: 978-849-0602
E-mail: mqnbofae@synqor.com
Web: www.synqor.com
Address: 155 Swanson Road
 Boxborough, MA 01719
 USA

Warranty

SynQor offers a two (2) year limited warranty. Complete warranty information is listed on our website or is available upon request from SynQor.

Information furnished by SynQor is believed to be accurate and reliable. However, no responsibility is assumed by SynQor for its use, nor for any infringements of patents or other rights of third parties which may result from its use. No license is granted by implication or otherwise under any patent or patent rights of SynQor.