

Features

- Resistance value as low as 0.001 ohm
- Power rating of 2 watts at 70 °C
- Inductance less than 5 nH
- RoHS compliant*

Applications

- Power supplies
- Stepper motor drives

CRF2512 - High Power Current Sense Chip Resistor

Electrical Characteristics

Power Rating @ 70 °C 0.001 to 0.010 ohms 0.015 to 0.040 ohms	2 W 1 W
Operating Temperature Range	-55 °C to +170 °C
Derated to Zero Load at	+170 °C
Maximum Working Voltage	(P x R) ^{1/2}
Insulation Resistance	> 100 megohms
Resistance Range	0.001 - 0.040 ohms
Resistance Tolerance	±1 %, ±5 %
Temperature Coefficient 0.001 to 0.002 ohms 0.003 to 0.010 ohms 0.015 to 0.040 ohms	±275 PPM/°C ±100 PPM/°C ±75 PPM/°C

Performance Characteristics

Test	Conditions	Specification
Thermal Shock	-55 °C to + 150 °C, 1000 Cycles, 15 minutes	ΔR ±(0.5 % + 0.0005 Ω)
Short Time Overload	5 X Rated Power for 5 seconds	ΔR ±(0.5 % + 0.0005 Ω)
Low Temperature Storage	-65°C for 24 hours	ΔR ±(0.5 % + 0.0005 Ω)
High Temperature Exposure	10000 hours @ + 170 °C	ΔR ±(1.0 % + 0.0005 Ω)
Bias Humidity	+ 85 °C, 85 % RH, 10 % Bias, 1000 hours	ΔR ±(0.5 % + 0.0005 Ω)
Mechanical Shock	100 g's for 6 milliseconds, 5 pulses	ΔR ±(0.5 % + 0.0005 Ω)
Vibration	Frequency varied 10 to 2000 KHz in one minute, 3 directions, 12 hours	ΔR ±(0.5% + 0.0005 Ω)
Load Life	1000 hours at rated power at +70 °C, 1.5 hours on, 0.5 hours off	ΔR ±(1.0% + 0.0005 Ω)
Resistance to Solder Heat	+260 °C Solder, 10-12 second dwell, 25 mm/second emergence	ΔR ±(0.5 % + 0.0005 Ω)
Moisture Resistance	MIL-STD-202 Method 106, 0 % power (7a and 7b not required)	ΔR ±(0.5% + 0.0005 Ω)

Recommended Solder Pad Layout

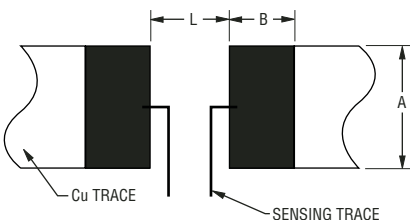

Resistance Range (Ω)	A	B	L
0.001-0.002	4.0 (0.157)	3.1 (0.122)	1.3 (0.051)
0.003-0.040	4.0 (0.157)	2.1 (0.083)	4.1 (0.161)

Product Dimensions

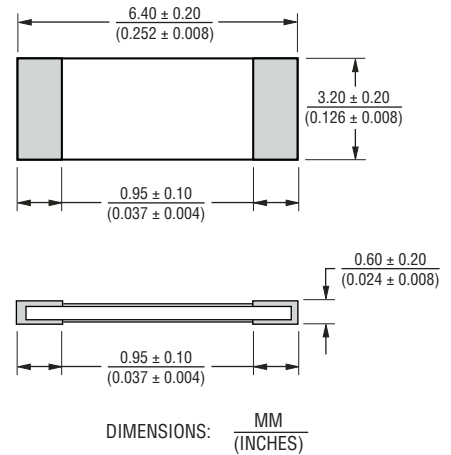

Construction

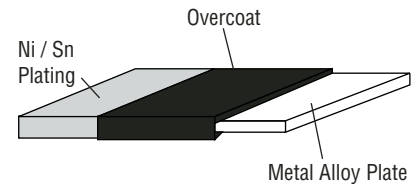

Derating Curve

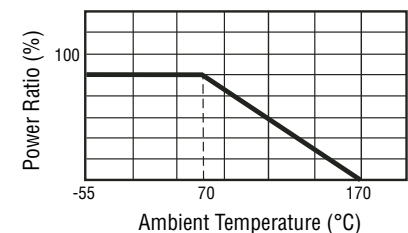

*RoHS Directive 2002/95/EC Jan 27 2003 including Annex.
Specifications are subject to change without notice.
Customers should verify actual device performance in their specific applications

CRF2512 - High Power Current Sense Chip Resistor

BOURNS®

Packaging Dimensions (Conforms to EIA RS-481A)

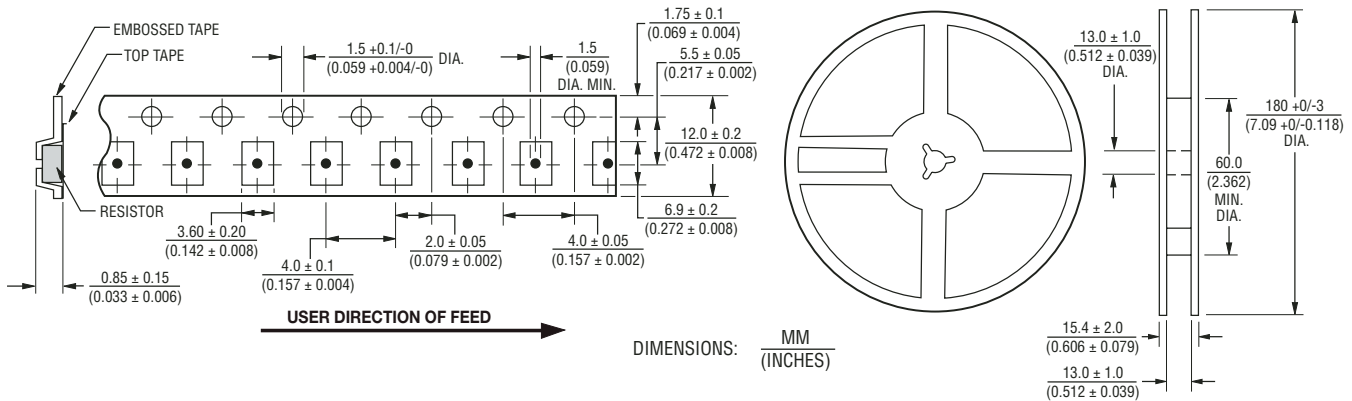

Resistance Value Table

Code	R Value
R001	0.001
R002	0.002
R003	0.003
R005	0.005
R007	0.007
R010	0.010
R015	0.015
R020	0.020
R025	0.025
R030	0.030
R035	0.035
R040	0.040

Soldering Profile

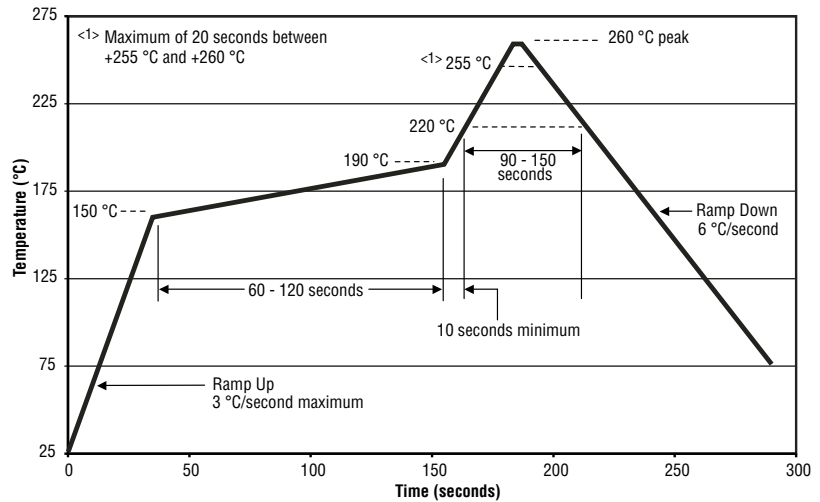

How to Order

CRF 2512 - F X - R003 E LF

Model _____
(CRF = Precision Chip Resistor)

Size _____
2512 = 2512 Size

Resistance Tolerance _____
• F = ±1 %
• J = ±5 %

TCR (PPM/°C) _____
• Z = ±75 PPM/°C, 0.015 ohm or greater
• X = ±100 PPM/°C, 0.003 ohm through 0.010 ohm
• V = ±275 PPM/°C, 0.001 ohm through 0.002 ohm

Resistance Value _____
"R" (decimal point) followed by three significant digits (example: R025 = 0.025 ohm)

Packaging _____
• E = 4,000 pieces on 180 mm (7 inch) reel

Termination _____
• LF = Tin-plated (RoHS compliant)

REV. 11/08

Specifications are subject to change without notice.
Customers should verify actual device performance in their specific applications