

**COIL FORMERS**

**General data for E42/21/15 coil former without pins**

PARAMETER	SPECIFICATION
Coil former material	polybutyleneterephthalate (PBT), glass reinforced, flame retardant in accordance with "UL 94V-0"; UL file number E45329(R)
Maximum operating temperature	155 C, "IEC 60085", class F

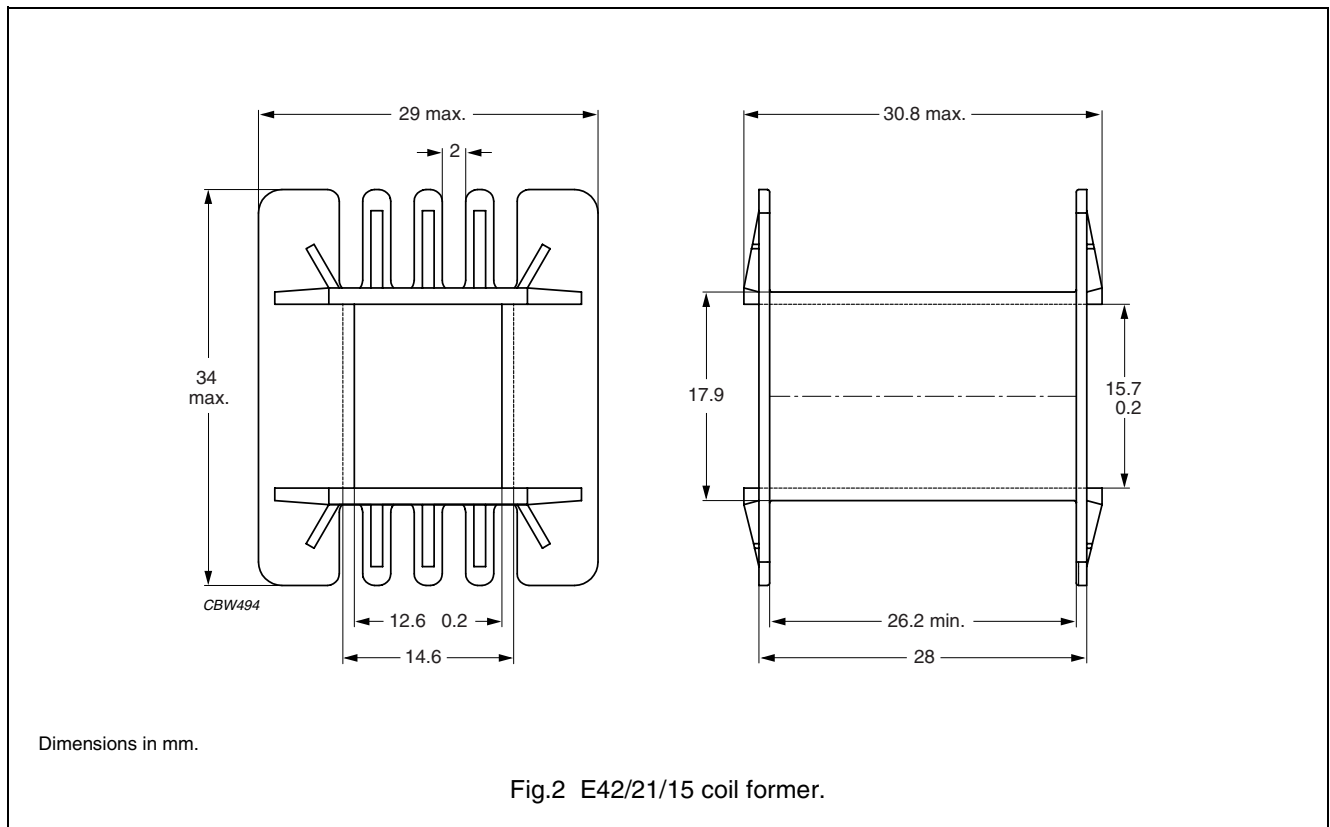

**Winding data for E42/21/15 coil former without pins**

NUMBER OF SECTIONS	WINDING AREA (mm <sup>2</sup> )	MINIMUM WINDING WIDTH (mm)	AVERAGE LENGTH OF TURN (mm)	TYPE NUMBER
1	178	26	93	CP-E42/21/15-1S