



# REALTEK

**ALC5611**

## **AC'97 AUDIO CODEC + TOUCH PANEL CONTROLLER**

### **DATASHEET**

**Rev. 1.3**  
**07 August 2009**  
**Track ID: JATR-1076-21**



**Realtek Semiconductor Corp.**

No. 2, Innovation Road II, Hsinchu Science Park, Hsinchu 300, Taiwan

Tel.: +886-3-578-0211. Fax: +886-3-577-6047

[www.realtek.com](http://www.realtek.com)

## COPYRIGHT

©2009 Realtek Semiconductor Corp. All rights reserved. No part of this document may be reproduced, transmitted, transcribed, stored in a retrieval system, or translated into any language in any form or by any means without the written permission of Realtek Semiconductor Corp.

## DISCLAIMER

Realtek provides this document “as is”, without warranty of any kind. Realtek may make improvements and/or changes in this document or in the product described in this document at any time. This document could include technical inaccuracies or typographical errors.

## TRADEMARKS

Realtek is a trademark of Realtek Semiconductor Corporation. Other names mentioned in this document are trademarks/registered trademarks of their respective owners.

## USING THIS DOCUMENT

This document is intended for the hardware and software engineer’s general information on the Realtek ALC5611 Audio Codec IC.

Though every effort has been made to ensure that this document is current and accurate, more information may have become available subsequent to the production of this guide.

## REVISION HISTORY

Revision	Release Date	Summary
1.0	2007/08/15	First release
1.1	2008/01/11	Revised section 1 General Description, page 1. Added note in Table 4, page 8. Revised section 7.5.5.1 Speaker Output, page 16. Revised section 7.6 Touch Panel Control, page 18. Revised Table 29, page 32. Revised Table 30, page 33. Revised Table 33, page 36. Added note in Table 81, page 56. Revised section 10 Application Circuits, page 66. Revised section 12 Ordering Information, page 69.
1.2	2008/07/23	Revised section 12 Ordering Information, page 69.
1.3	2009/08/07	Revised Figure 1 Block Diagram, page 4. Revised Table 3 Filter/Reference, page 8. Revised Table 4 Power/Ground, page 8. Revised Table 83 Analog Performance Characteristics, page 57. Added section 9.3.8 I <sup>2</sup> S/PCM Interface Master Mode, page 64. Added section 9.3.9 I <sup>2</sup> S/PCM Interface Slave Mode, page 65. Revised section 11 Mechanical Dimensions, page 67. Revised Table 93 Ordering Information, page 69.

## Table of Contents

<b>1. GENERAL DESCRIPTION .....</b>	<b>1</b>
<b>2. FEATURES .....</b>	<b>2</b>
<b>3. SYSTEM APPLICATIONS .....</b>	<b>3</b>
<b>4. FUNCTION BLOCK DIAGRAM.....</b>	<b>4</b>
4.1. FUNCTION BLOCK .....	4
4.2. AUDIO MIXER PATH .....	5
<b>5. PIN ASSIGNMENTS.....</b>	<b>6</b>
5.1. GREEN PACKAGE AND VERSION IDENTIFICATION .....	6
<b>6. PIN DESCRIPTIONS.....</b>	<b>7</b>
6.1. AC'97 DIGITAL I/O PINS.....	7
6.2. ANALOG I/O PINS .....	7
6.3. FILTER/REFERENCE.....	8
6.4. POWER/GROUND.....	8
<b>7. FUNCTIONAL DESCRIPTION .....</b>	<b>9</b>
7.1. POWER .....	9
7.2. RESET .....	9
7.2.1. <i>Power-On Reset (POR)</i> .....	9
7.3. CLOCKING.....	10
7.3.1. <i>Phase-Locked Loop</i> .....	10
7.3.2. <i>AC'97 Mode</i> .....	10
7.4. DIGITAL DATA INTERFACE.....	11
7.4.1. <i>AC-Link</i> .....	11
7.5. AUDIO DATA PATH.....	13
7.5.1. <i>Stereo ADC</i> .....	13
7.5.2. <i>Stereo DAC</i> .....	13
7.5.3. <i>Mixers</i> .....	13
7.5.4. <i>Analog Audio Input Path</i> .....	15
7.5.5. <i>Analog Audio Output Data Path</i> .....	16
7.6. TOUCH PANEL CONTROL .....	18
7.7. AVC CONTROL .....	19
7.8. HARDWARE SOUND EFFECTS .....	20
7.8.1. <i>Equalizer Block</i> .....	20
7.8.2. <i>Pseudo Stereo and Spatial 3D Sound</i> .....	20
7.9. ODD-ADDRESSED REGISTER ACCESS.....	20
7.10. POWER MANAGEMENT.....	21
7.10.1. <i>Sleep Mode</i> .....	21
7.11. GPIO AND INTERRUPT .....	22
<b>8. MIXER REGISTERS LIST.....</b>	<b>23</b>
8.1. REG-00H: RESET .....	23
8.2. REG-02H: SPEAKER OUTPUT VOLUME.....	23
8.3. REG-04H: HEADPHONE OUTPUT VOLUME.....	24
8.4. REG-08H: PHONE INPUT/MONO OUTPUT VOLUME.....	24
8.5. REG-0AH: LINE_IN VOLUME .....	25
8.6. REG-0CH: STEREO DAC VOLUME.....	25

8.7.	REG-0EH: MIC VOLUME .....	25
8.8.	REG-10H: MIC ROUTING CONTROL .....	26
8.9.	REG-12H: ADC RECORD GAIN.....	26
8.10.	REG-14H: ADC RECORD MIXER CONTROL.....	27
8.11.	REG-1CH: OUTPUT MIXER CONTROL .....	27
8.12.	REG-22H: MICROPHONE CONTROL .....	28
8.13.	REG-26H: POWER DOWN CONTROL/STATUS .....	29
8.14.	REG-2AH: TONE CONTROL .....	30
8.15.	REG-2CH: AC'97 STEREO DAC RATE/DPE RATE .....	30
8.16.	REG-32H: AC'97 STEREO ADC RATE .....	31
8.17.	REG-3AH: POWER MANAGEMENT ADDITION 1 .....	32
8.18.	REG-3CH: POWER MANAGEMENT ADDITION 2 .....	33
8.19.	REG-3EH: POWER MANAGEMENT ADDITION 3 .....	34
8.20.	REG-40H: GENERAL PURPOSE CONTROL REGISTER 1 .....	35
8.21.	REG-42H: GENERAL PURPOSE CONTROL REGISTER 2 .....	36
8.22.	REG-44H: PLL CONTROL .....	36
8.22.1.	AC-Link PLL Clock Setting Table (Unit: MHz) .....	37
8.23.	REG-4CH: GPIO PIN CONFIGURATION .....	37
8.24.	REG-4EH: GPIO PIN POLARITY .....	38
8.25.	REG-50H: GPIO PIN STICKY .....	38
8.26.	REG-52H: GPIO PIN WAKE-UP .....	39
8.27.	REG-54H: GPIO PIN STATUS .....	40
8.28.	REG-56H: PIN SHARING .....	40
8.29.	REG-58H: OVER-TEMP/CURRENT STATUS.....	42
8.30.	REG-5CH: GPIO_OUTPUT PIN CONTROL.....	42
8.31.	REG-5EH: MISC CONTROL.....	43
8.32.	REG-68H: PSEUDO STEREO AND SPATIAL EFFECT BLOCK CONTROL .....	44
8.33.	REG-6AH: INDEX ADDRESS.....	45
8.34.	REG-6CH: INDEX DATA .....	45
8.35.	REG-6EH: EQ STATUS .....	46
8.36.	INDEX-00H: EQ BAND-0 COEFFICIENT (LP0: A1) .....	46
8.37.	INDEX-01H: EQ BAND-0 GAIN (LP0: Ho).....	46
8.38.	INDEX-02H: EQ BAND-1 COEFFICIENT (BP1: A1) .....	47
8.39.	INDEX-03H: EQ BAND-1 COEFFICIENT (BP1: A2) .....	47
8.40.	INDEX-04H: EQ BAND-1 GAIN (BP1: Ho) .....	47
8.41.	INDEX-05H: EQ BAND-2 COEFFICIENT (BP2: A1) .....	47
8.42.	INDEX-06H: EQ BAND-2 COEFFICIENT (BP2: A2) .....	47
8.43.	INDEX-07H: EQ BAND-2 GAIN (BP2: Ho) .....	48
8.44.	INDEX-08H: EQ BAND-3 COEFFICIENT (BP3: A1) .....	48
8.45.	INDEX-09H: EQ BAND-3 COEFFICIENT (BP3: A2) .....	48
8.46.	INDEX-0AH: EQ BAND-3 GAIN (BP3: Ho).....	48
8.47.	INDEX-0BH: EQ BAND-4 COEFFICIENT (HPF: A1) .....	48
8.48.	INDEX-0CH: EQ BAND-4 GAIN (HPF: Ho) .....	49
8.49.	INDEX-10H: EQ CONTROL AND STATUS REGISTER .....	49
8.50.	INDEX-11H: EQ INPUT VOLUME CONTROL .....	49
8.51.	INDEX-12H: EQ OUTPUT VOLUME CONTROL.....	50
8.52.	INDEX-20H: AUTO VOLUME CONTROL REGISTER 0 .....	50
8.53.	INDEX-21H: AUTO VOLUME CONTROL REGISTER 1 .....	51
8.54.	INDEX-22H: AUTO VOLUME CONTROL REGISTER 2 .....	51
8.55.	INDEX-23H: AUTO VOLUME CONTROL REGISTER 3 .....	51
8.56.	INDEX-24H: AUTO VOLUME CONTROL REGISTER 4 .....	51
8.57.	INDEX-25H: AUTO VOLUME CONTROL REGISTER 5 .....	52
8.58.	INDEX-39H: DIGITAL INTERNAL REGISTER.....	52
8.59.	INDEX-4AH: CLASS-D TEMPERATURE SENSOR.....	52
8.60.	INDEX-54H: AD_DA_MIXER_INTERNAL REGISTER .....	53

---

8.61.	REG-74H: TOUCH PANEL CONTROL BYTE 1 .....	53
8.62.	REG-76H: TOUCH PANEL CONTROL BYTE 2 .....	54
8.63.	REG-78H: TOUCH PANEL INDICATION.....	55
8.64.	REG-7CH: VENDOR ID 1 .....	55
8.65.	REG-7EH: VENDOR ID 2.....	55
<b>9.</b>	<b>ELECTRICAL CHARACTERISTICS.....</b>	<b>56</b>
9.1.	DC CHARACTERISTICS.....	56
9.1.1.	<i>Absolute Maximum Ratings</i> .....	56
9.1.2.	<i>Recommended Operating Conditions</i> .....	56
9.1.3.	<i>Static Characteristics</i> .....	56
9.2.	ANALOG PERFORMANCE CHARACTERISTICS.....	57
9.3.	SIGNAL TIMING .....	60
9.3.1.	<i>Cold Reset</i> .....	60
9.3.2.	<i>Warm Reset</i> .....	60
9.3.3.	<i>AC-Link Clocks</i> .....	61
9.3.4.	<i>AC-Link Data Output and Input Timing</i> .....	61
9.3.5.	<i>AC-Link Signal Rise and Fall Timing</i> .....	62
9.3.6.	<i>AC-Link Low Power Mode Timing</i> .....	63
9.3.7.	<i>AC-Link IO Pin Capacitance and Loading</i> .....	63
9.3.8.	<i>I<sup>2</sup>S/PCM Interface Master Mode</i> .....	64
9.3.9.	<i>I<sup>2</sup>S/PCM Interface Slave Mode</i> .....	65
<b>10.</b>	<b>APPLICATION CIRCUITS .....</b>	<b>66</b>
<b>11.</b>	<b>MECHANICAL DIMENSIONS .....</b>	<b>67</b>
<b>12.</b>	<b>ORDERING INFORMATION .....</b>	<b>69</b>

---

## List of Tables

TABLE 1.	AC'97 DIGITAL I/O PINS .....	7
TABLE 2.	ANALOG I/O PINS .....	7
TABLE 3.	FILTER/REFERENCE .....	8
TABLE 4.	POWER/GROUND .....	8
TABLE 5.	POWER SETTING FOR BEST PERFORMANCE .....	9
TABLE 6.	RESET OPERATION .....	9
TABLE 7.	POWER ON RESET VOLTAGE .....	9
TABLE 8.	AC-LINK CLOCK SETTING TABLE (UNIT: MHZ) .....	10
TABLE 9.	PIN SHARING CONFIGURATION TABLE .....	16
TABLE 10.	REG-00H: RESET .....	23
TABLE 11.	REG-02H: SPEAKER OUTPUT VOLUME .....	23
TABLE 12.	REG-04H: HEADPHONE OUTPUT VOLUME .....	24
TABLE 13.	REG-08H: PHONE INPUT/MONO OUTPUT VOLUME .....	24
TABLE 14.	REG-0AH: LINE_IN VOLUME .....	25
TABLE 15.	REG-0CH: STEREO DAC VOLUME .....	25
TABLE 16.	REG-0EH: MIC VOLUME .....	25
TABLE 17.	REG-10H: MIC ROUTING CONTROL .....	26
TABLE 18.	REG-12H: ADC RECORD GAIN .....	26
TABLE 19.	REG-14H: ADC RECORD MIXER CONTROL .....	27
TABLE 20.	REG-1CH: OUTPUT MIXER CONTROL .....	27
TABLE 21.	REG-22H: MICROPHONE CONTROL .....	28
TABLE 22.	REG-26H: POWER DOWN CONTROL/STATUS .....	29
TABLE 23.	TRUTH TABLE FOR POWER DOWN MODE (PD=POWER DOWN) .....	30
TABLE 24.	REG-2AH: TONE CONTROL .....	30
TABLE 25.	REG-2CH: AC'97 STEREO DAC RATE/DPE RATE .....	30
TABLE 26.	PC99/PC2001 DESIGN GUIDE SAMPLING RATES .....	30
TABLE 27.	REG-32H: AC'97 STEREO ADC RATE .....	31
TABLE 28.	PC99/PC2001 DESIGN GUIDE SAMPLING RATES .....	31
TABLE 29.	REG-3AH: POWER MANAGEMENT ADDITION 1 .....	32
TABLE 30.	REG-3CH: POWER MANAGEMENT ADDITION 2 .....	33
TABLE 31.	REG-3EH: POWER MANAGEMENT ADDITION 3 .....	34
TABLE 32.	REG-40H: GENERAL PURPOSE CONTROL REGISTER 1 .....	35
TABLE 33.	REG-42H: GENERAL PURPOSE CONTROL REGISTER 2 .....	36
TABLE 34.	REG-44H: PLL CONTROL .....	36
TABLE 35.	AC-LINK PLL CLOCK SETTING TABLE (UNIT: MHZ) .....	37
TABLE 36.	REG-4CH: GPIO PIN CONFIGURATION .....	37
TABLE 37.	REG-4EH: GPIO PIN POLARITY .....	38
TABLE 38.	REG-50H: GPIO PIN STICKY .....	38
TABLE 39.	REG-52H: GPIO PIN WAKE-UP .....	39
TABLE 40.	REG-54H: GPIO PIN STATUS .....	40
TABLE 41.	REG-56H: PIN SHARING .....	40
TABLE 42.	GPIO AND IRQ LOGIC .....	41
TABLE 43.	REG-58H: OVER-TEMP/CURRENT STATUS .....	42
TABLE 44.	REG-5CH: GPIO_OUTPUT PIN CONTROL .....	42
TABLE 45.	REG-5EH: MISC CONTROL .....	43
TABLE 46.	REG-68H: PSEUDO STEREO AND SPATIAL EFFECT BLOCK CONTROL .....	44
TABLE 47.	REG-6AH: INDEX ADDRESS .....	45
TABLE 48.	REG-6CH: INDEX DATA .....	45
TABLE 49.	REG-6EH: EQ STATUS .....	46
TABLE 50.	INDEX-00H: EQ BAND-0 COEFFICIENT (LP0: A1) .....	46
TABLE 51.	INDEX-01H: EQ BAND-0 GAIN (LP0: Ho) .....	46
TABLE 52.	INDEX-02H: EQ BAND-1 COEFFICIENT (BP1: A1) .....	47

TABLE 53.	INDEX-03H: EQ BAND-1 COEFFICIENT (BP1: A2).....	47
TABLE 54.	INDEX-04H: EQ BAND-1 GAIN (BP1: Ho).....	47
TABLE 55.	INDEX-05H: EQ BAND-2 COEFFICIENT (BP2: A1).....	47
TABLE 56.	INDEX-06H: EQ BAND-2 COEFFICIENT (BP2: A2).....	47
TABLE 57.	INDEX-07H: EQ BAND-2 GAIN (BP2: Ho).....	48
TABLE 58.	INDEX-08H: EQ BAND-3 COEFFICIENT (BP3: A1).....	48
TABLE 59.	INDEX-09H: EQ BAND-3 COEFFICIENT (BP3: A2).....	48
TABLE 60.	INDEX-0AH: EQ BAND-3 GAIN (BP3: Ho).....	48
TABLE 61.	INDEX-0BH: EQ BAND-4 COEFFICIENT (HPF: A1).....	48
TABLE 62.	INDEX-0CH: EQ BAND-4 GAIN (HPF: Ho).....	49
TABLE 63.	INDEX-10H: EQ CONTROL AND STATUS REGISTER.....	49
TABLE 64.	INDEX-11H: EQ INPUT VOLUME CONTROL.....	49
TABLE 65.	INDEX-12H: EQ OUTPUT VOLUME CONTROL.....	50
TABLE 66.	INDEX-20H: AUTO VOLUME CONTROL REGISTER 0.....	50
TABLE 67.	INDEX-21H: AUTO VOLUME CONTROL REGISTER 1.....	51
TABLE 68.	INDEX-22H: AUTO VOLUME CONTROL REGISTER 2.....	51
TABLE 69.	INDEX-23H: AUTO VOLUME CONTROL REGISTER 3.....	51
TABLE 70.	INDEX-24H: AUTO VOLUME CONTROL REGISTER 4.....	51
TABLE 71.	INDEX-25H: AUTO VOLUME CONTROL REGISTER 5.....	52
TABLE 72.	INDEX-39H: DIGITAL INTERNAL REGISTER.....	52
TABLE 73.	INDEX-4AH: CLASS-D TEMPERATURE SENSOR.....	52
TABLE 74.	INDEX-54H: AD_DA_MIXER_INTERNAL REGISTER.....	53
TABLE 75.	REG-74H: TOUCH PANEL CONTROL BYTE 1.....	53
TABLE 76.	REG-76H: TOUCH PANEL CONTROL BYTE 2.....	54
TABLE 77.	REG-78H: TOUCH PANEL INDICATION.....	55
TABLE 78.	REG-7CH: VENDOR ID 1.....	55
TABLE 79.	REG-7EH: VENDOR ID 2.....	55
TABLE 80.	ABSOLUTE MAXIMUM RATINGS.....	56
TABLE 81.	RECOMMENDED OPERATING CONDITIONS.....	56
TABLE 82.	STATIC CHARACTERISTICS.....	56
TABLE 83.	ANALOG PERFORMANCE CHARACTERISTICS.....	57
TABLE 84.	COLD RESET TIMING PARAMETERS.....	60
TABLE 85.	WARM RESET TIMING PARAMETERS.....	60
TABLE 86.	AC-LINK CLOCK PARAMETERS.....	61
TABLE 87.	AC-LINK DATA TIMING PARAMETERS.....	61
TABLE 88.	AC-LINK SIGNAL RISE AND FALL TIMING PARAMETERS.....	62
TABLE 89.	AC-LINK LOW POWER MODE TIMING PARAMETERS.....	63
TABLE 90.	AC-LINK IO PIN CAPACITANCE PARAMETERS.....	63
TABLE 91.	TIMING OF I <sup>2</sup> S/PCM MASTER MODE.....	64
TABLE 92.	I <sup>2</sup> S/PCM SLAVE MODE TIMING.....	65
TABLE 93.	ORDERING INFORMATION.....	69

---

## List of Figures

---

FIGURE 1.	BLOCK DIAGRAM .....	4
FIGURE 2.	AUDIO MIXER PATH .....	5
FIGURE 3.	PIN ASSIGNMENTS .....	6
FIGURE 4.	AC-LINK WAKE UP TIMING .....	11
FIGURE 5.	DEFAULT ALC5611 SLOT ARRANGEMENT – CODEC ID ALWAYS 00 .....	12
FIGURE 6.	CONTROLLER AND CODEC CONNECTION .....	12
FIGURE 7.	4-WIRE RESISTIVE TOUCH PANEL CIRCUIT .....	18
FIGURE 8.	AUTO VOLUME CONTROL BLOCK DIAGRAM .....	19
FIGURE 9.	EXAMPLE OF ALC5611 POWER-DOWN/POWER-UP FLOW .....	21
FIGURE 10.	GPIO IMPLEMENTATION .....	22
FIGURE 11.	POWER CONTROL TO MIC INPUT .....	35
FIGURE 12.	GPIO AND IRQ LOGIC .....	41
FIGURE 13.	JACK-INSERT-DETECT PULL UP RESISTOR IMPLEMENTED VIA AN EXTERNAL CIRCUIT .....	44
FIGURE 14.	COLD RESET TIMING .....	60
FIGURE 15.	WARM RESET TIMING .....	60
FIGURE 16.	DATA OUTPUT AND INPUT TIMING .....	61
FIGURE 17.	SIGNAL RISE AND FALL TIMING .....	62
FIGURE 18.	AC-LINK LOW POWER MODE TIMING .....	63
FIGURE 19.	TIMING OF I <sup>2</sup> S/PCM MASTER MODE .....	64
FIGURE 20.	I <sup>2</sup> S/PCM SLAVE MODE TIMING .....	65

---



# 1. General Description

The ALC5611 is a highly-integrated AC'97 interface audio codec with multiple input/output ports and a 4-wire touch panel controller.

The ALC5611 is designed for mobile computing and communications.

Stereo audio is supported via the AC'97 interface. To reduce component count, the device can connect directly to:

- A 4-wire touch panel
- MONO or stereo differential analog inputs
- Stereo headphone
- Single-ended or BTL MONO output
- MONO or Stereo Bridge-Tied Load (BTL) speaker

Multiple analog input and output pins are provided for seamless integration with analog connected wireless communication devices. Differential input/output connections efficiently reduce noise interference, providing better sound quality. Class-AB or Class-D amplifiers are easily swapped via simple register configuration, and the 1.7 Watt speaker removes the need for an additional amplifier, further cutting both cost and required board area. Additionally, a flexible hardware 5-band equalizer with configurable gain, bandwidth, and center frequency, and enriches the sound experience.

ALC5611 Digital power operates at supply voltages from 1.8V to 3.6V. Analog power operates from 2.3V to 3.6V, and Speaker power operates from 2.3V to 5V. To extend battery life, each section of the device can be powered down individually under software control. Leakage current in maximum power saving state is less than 10 $\mu$ A.

The ALC5611 is available in a 7x7mm 'Green' QFN package, making it ideal for use in handheld portable systems.

## 2. Features

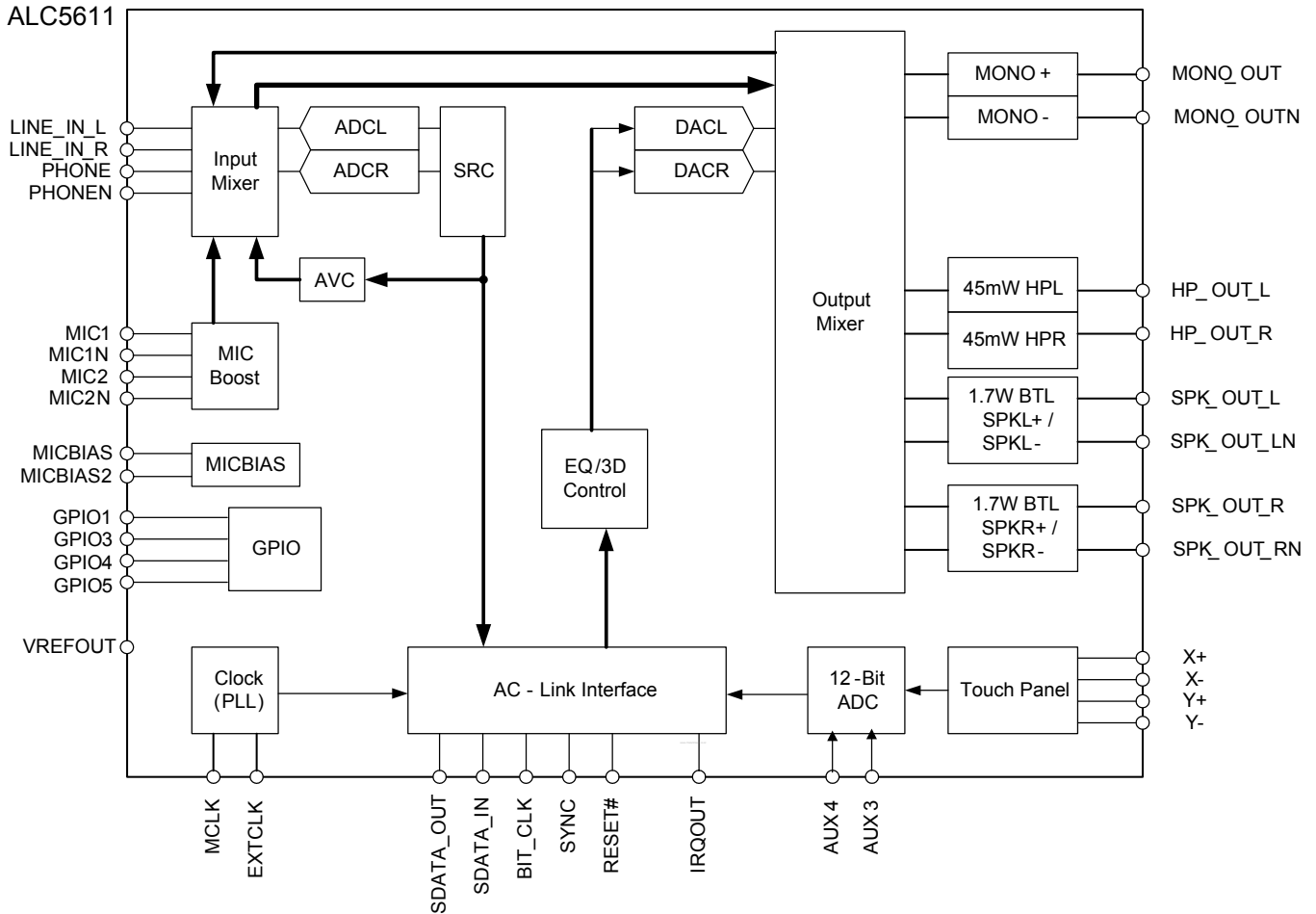
- Single-chip AC'97 Rev 2.2 compatible codec
  - ◆ 16-bit DAC SNR 90dB, THD+N -85dB
  - ◆ 16-bit ADC SNR 85dB, THD+N -80dB
  - ◆ Supports all WinCE variable rates (8kHz, 11.025kHz, 16kHz, 22.05kHz, 24kHz, 32kHz, 44.1kHz, 48kHz)
- One analog stereo input (LINE-IN)
- One analog MONO single-ended or differential input (PHONE and PHONEN input)
- Stereo, single-ended MONO, or differential analog microphone inputs, with boost pre-amplifiers (+20/+30/+40dB)
- BTL (Bridge-Tied Load) Max. output with on-chip 1.7W speaker driver (SPKVDD=5V, 8Ω load, 10% THD+N)
- Stereo headphone output with on-chip 45mW headphone driver (HPVDD=3.3V, 16Ω load)
- 25mW SE or 75mW BTL MONO output support (AVDD=3.3V, 32Ω load)
- Microphone switch detection
- Power management and enhanced power saving
- Supports digital 5-band equalizer (EQ)
- Supports digital spatial sound and pseudo stereo effect
- Supports pop noise suppression
- Internal PLL can receive wide range of clock input (Digital IO power > 1.8V)
- Digital power supplies from 1.8V to 3.6V, speaker amplifier power supplies from 2.3V to 5V
- Analog power, headphone power, and touch panel power supplies from 2.3V to 3.6V
- Resistive touch panel interface
  - ◆ Supports 4-wire panel
  - ◆ X, Y axis and pressure measurement
  - ◆ 12-bit resolution AUX\_ADC for battery measurement, DNL<±1 LSB, INL<±2 LSBs
  - ◆ Supports pen-down detection in power down mode
- 48-pin QFN package

### **3. System Applications**

- Tablet PC system/Ultra-Mobile PC (UMPC)
- GPS/Personal Navigation Device (PND) or Multi-Media phone
- PDA Phone/Smartphone
- Personal Media Player (PMP)

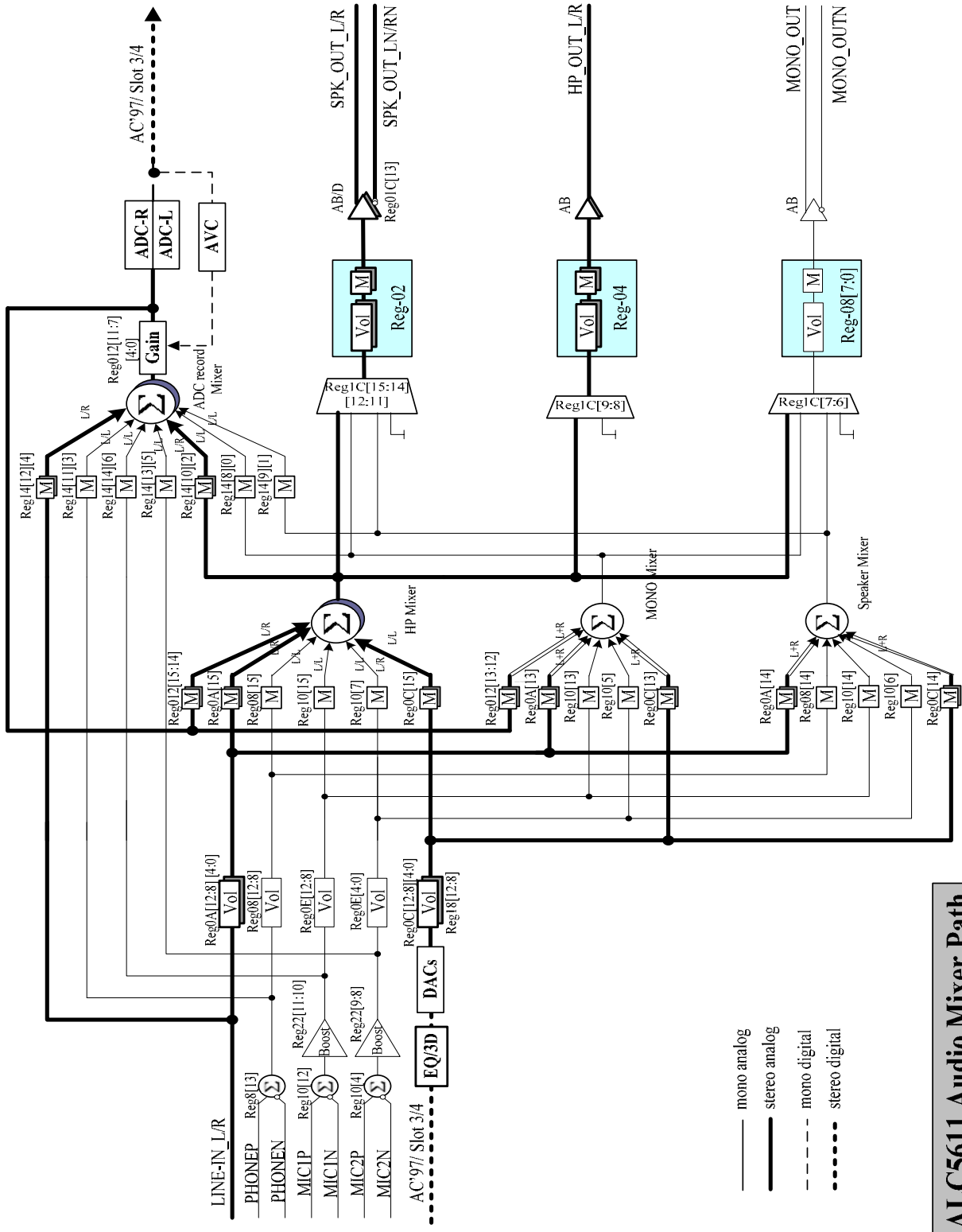
## 4. Function Block Diagram

### 4.1. Function Block



**Figure 1. Block Diagram**

## 4.2. Audio Mixer Path



**ALC5611 Audio Mixer Path**

**Figure 2. Audio Mixer Path**

## 5. Pin Assignments

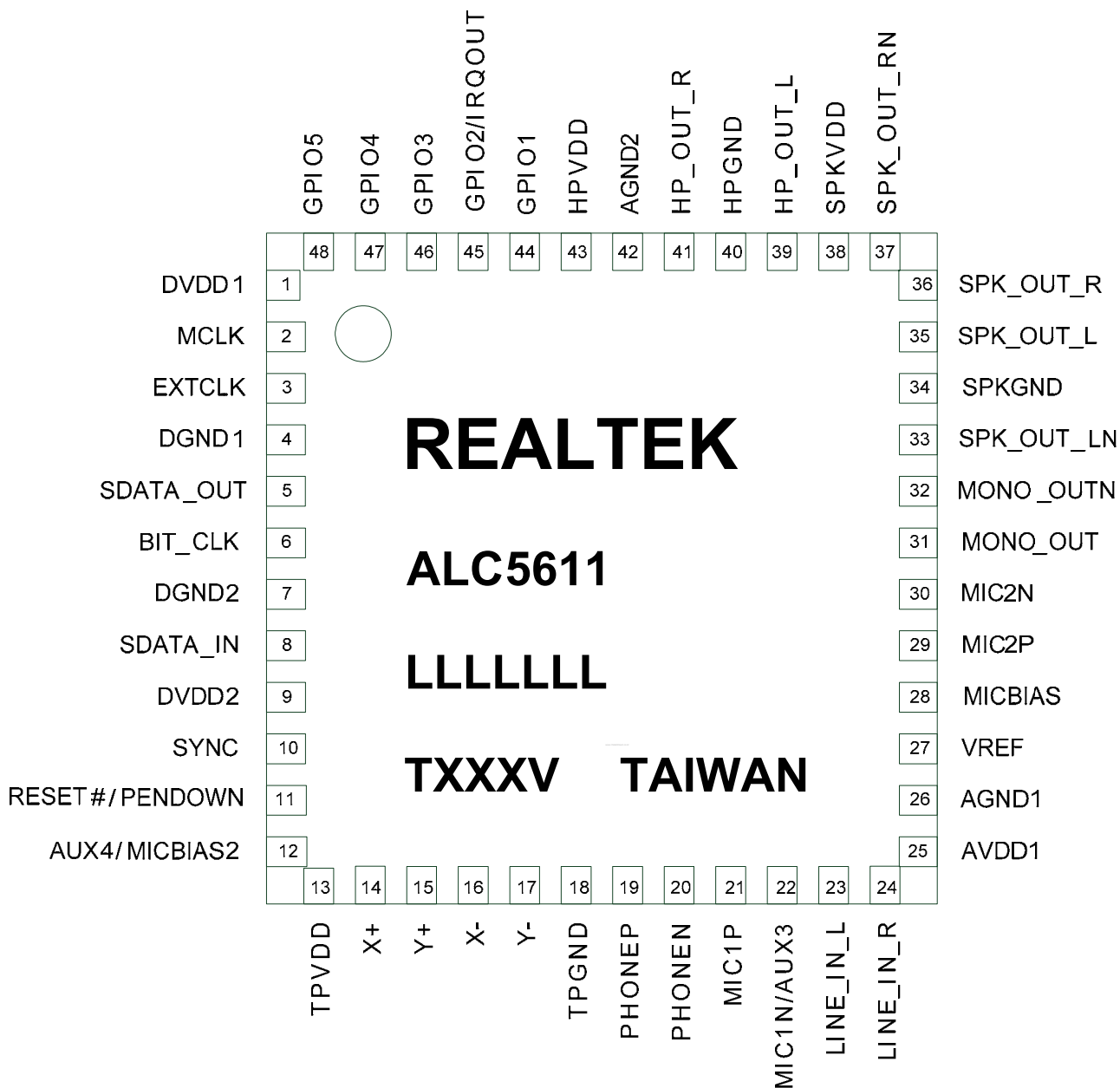


Figure 3. Pin Assignments

### 5.1. Package and Version Identification

‘Green’ package is indicated by a ‘G’ in the location marked ‘T’ in Figure 3.

## 6. Pin Descriptions

### 6.1. AC'97 Digital I/O Pins

**Table 1. AC'97 Digital I/O Pins**

Name	Type	Pin	Description	Characteristic Definition
MCLK	I	2	Master Clock Input	Schmitt trigger
EXTCLK	IO	3	External Reference Clock Input/Output	Output: $V_{OL}=0.1*DVDD$ , $V_{OH}=0.9*DVDD$ Input: Schmitt trigger
SDATA_OUT	I	5	Serial TDM Data Input	Schmitt trigger
BIT_CLK	O	6	Bit Clock Output	$V_{OL}=0.1*DVDD$ , $V_{OH}=0.9*DVDD$
SDATA_IN	O	8	Serial TDM Data Output	$V_{OL}=0.1*DVDD$ , $V_{OH}=0.9*DVDD$
SYNC	I	10	48khz Synchronous Input Signal	Schmitt trigger
RESET#/ PENDOWN	I/O	11	H/W Reset Input Pen-down Output	Schmitt trigger
GPIO1	IO	44	General Purpose Input And Output 1	GPIO: Input/Output
GPIO2/ IRQOUT	IO	45	General Purpose Input And Output 2/ Interrupt Output	GPIO: Input/Output IRQOUT: Output
GPIO3	IO	46	General Purpose Input And Output 3	GPIO: Input/Output
GPIO4	IO	47	General Purpose Input And Output 4	GPIO: Input/Output
GPIO5	IO	48	General Purpose Input And Output 5	GPIO: Input/Output
				Total: 12 Pins

### 6.2. Analog I/O Pins

**Table 2. Analog I/O Pins**

Name	Type	Pin	Description	Characteristic Definition
AUX4/ MICBIAS2	IO	12	Auxiliary Input 4/ MIC BIAS Voltage Output 2	Analog input (1Vrms) / Programmable Analog DC Output with 3mA drive
X+	IO	14	Touch Panel Connect Input/Output	X+ for 4-wire panel
Y+	IO	15	Touch Panel Connect Input/Output	Y+ for 4-wire panel
X-	IO	16	Touch Panel Connect Input/Output	X- for 4-wire panel
Y-	IO	17	Touch Panel Connect Input/Output	Y- for 4-wire panel
PHONEP	I	19	Phone Positive Input	Analog Input (1Vrms)
PHONEN	I	20	Phone Negative Input	Analog Input (1Vrms)
MIC1P	I	21	First Mic Positive Input	Analog Input (1Vrms)
MIC1N/AUX3	I	22	First Mic Negative Input/ Auxiliary Input 3	Analog Input (1Vrms)
MIC2P	I	29	Second Mic Positive Input	Analog Input (1Vrms)
MIC2N	I	30	Second Mic Negative Input	Analog Input (1Vrms)
LINE_IN_L	I	23	Line Input Left Channel	Analog Input (1Vrms)
LINE_IN_R	I	24	Line Input Right Channel	Analog Input (1Vrms)
MONO_OUT	O	31	Positive MONO Output	Analog Output (1Vrms)

Name	Type	Pin	Description	Characteristic Definition
MONO_OUTN	O	32	Negative MONO Output	Analog Output (1Vrms)
HP_OUT_L	O	39	Headphone Output Left Channel	Analog Output (1Vrms)
HP_OUT_R	O	41	Headphone Output Right Channel	Analog Output (1Vrms)
SPK_OUT_L	O	35	Speaker Output Left Channel	Analog Output (1.3Vrms, SPKVDD=4.2V)
SPK_OUT_LN	O	33	Negative Speaker Output Left Channel	Analog Output (1.3Vrms, SPKVDD=4.2V)
SPK_OUT_R	O	36	Speaker Output Right Channel	Analog Output (1.3Vrms, SPKVDD=4.2V)
SPK_OUT_RN	O	37	Negative Speaker Output Right Channel	Analog Output (1.3Vrms, SPKVDD=4.2V)
				Total: 21 Pins

### 6.3. Filter/Reference

**Table 3. Filter/Reference**

Name	Type	Pin	Description	Characteristic Definition
MICBIAS	O	28	MIC BIAS Voltage Output	Programmable Analog DC Output with 3mA drive
VREF	O	27	Internal Reference Voltage	4.7 $\mu$ F capacitor to analog ground
				Total: 2 Pins

### 6.4. Power/Ground

**Table 4. Power/Ground**

Name	Type	Pin	Description	Characteristic Definition
DVDD1	P	1	Digital VDD	1.8V~3.6V (IO)
DGND1	P	4	Digital GND	-
DGND2	P	7	Digital GND	-
DVDD2	P	9	Digital VDD	1.8V~3.6V (Core)
TPVDD	P	13	Analog VDD for Touch Panel	2.3V~3.6V
TPGND	P	18	Analog GND for Touch Panel	-
AVDD1	P	25	Analog VDD	2.3V~3.6V
AGND1	P	26	Analog GND	-
SPKGND	P	34	Analog GND for Speaker Amps	-
SPKVDD	P	38	Analog VDD for Speaker Amps	3.0V~5V (for ohm loading) 2.3V~5V (for ohm loading)
HPGND	P	40	Analog GND for Headphone Amps	-
AGND2	P	42	Analog GND	-
HPVDD	P	43	Analog VDD for Headphone Amps	2.3V~3.6V
Exposed_GND	P	49	Thermal Pad Must be Connected to System GND	-
				Total: 14 Pins

Note1: DVDD1  $\geq$  DVDD2, SPKVDD  $\geq$  AVDD1, HPVDD  $\geq$  AVDD1  $\geq$  DVDD2, TPVDD  $\geq$  DVDD2.

Note2: SPDVDD connect 10 $\mu$ F Capacitor to SPKGND is required.

Note3: The Thermal pad must be connected to system ground.



## 7. Functional Description

### 7.1. Power

The ALC5611 has many power blocks. SPKVDD operates between 2.3V and 5V. HPVDD, TPVDD and AVDD1 operate between 2.3V and 3.6V. DVDD1 and DVDD2 operate between 1.8V and 3.6V. The power supply limit conditions are  $DVDD1 \geq DVDD2$ ,  $SPKVDD \geq AVDD1$ ,  $HPVDD \geq AVDD1 \geq DVDD2$ ,  $TPVDD \geq DVDD2$ , and  $AVDD1 = TPVDD$ .

**Table 5. Power Setting for Best Performance**

Power Setting	DVDD1	DVDD2	HPVDD	TPVDD	AVDD1	SPKVDD
	3.3V	1.8V	3.3V	3.3V	3.3V	4.2V

### 7.2. Reset

There are 4 types of reset operation: Power-On Reset (POR), Cold, Warm, and Register reset.

**Table 6. Reset Operation**

Reset Type	Trigger Condition	CODEC Response
POR	Power-On Reset. Monitor digital power supply voltage reaches $V_{POR}$	Resets all hardware logic and all registers to default values.
Cold Reset	Asserts RESET# for a specified period	Resets all hardware logic and all registers to default values except some PLL related control registers and logic.
Register Reset	Write Reg-00h	Resets all registers to default values except some PLL related control registers and logic.
Warm Reset	Drives SYNC high for specified period without BIT_CLK	Reactivates AC-Link. No change to register values.

#### 7.2.1. Power-On Reset (POR)

When powered on, DVDD2 passes through the  $V_{POR}$  band of the ALC5611 ( $V_{POR\_ON} \sim V_{POR\_OFF}$ ), the Power On Reset (POR) will generate an internal reset signal (POR reset 'LOW') to reset the whole chip.

**Table 7. Power On Reset Voltage**

Symbol	Min	Typical	Max	Unit
$V_{POR\_ON}$	1.0	-	1.6	V
$V_{POR\_OFF}$	-	1.3	-	V

Note:  $V_{POR\_OFF}$  must be below  $V_{POR\_ON}$ .

## 7.3. Clocking

The Stereo\_SYSCLK can be selected from MCLK or PLL. This means MCLK is always provided externally, and the driver should arrange the clock of each block and setup each divider.

### 7.3.1. Phase-Locked Loop

A Phase-Locked Loop (PLL) is used to provide a flexible input clock from 2.048MHz to 40MHz. Typical choices are 2.048MHz, 4.096MHz, and 13MHz. The source of the PLL can be set to MCLK or MCLK/2 by setting PLL\_pre\_div.

The ALC5611 SYSCLK frequency is 24.576MHz. If the system cannot provide 24.576MHz to the ALC5611, the PLL of the ALC5611 can be used to generate a frequency near 24.576MHz. As the PLL parameter is configured through the AC link, the input clock to the MCLK pin must be between 2.048MHz and 80MHz. After the AC link is connected, the driver must configure the PLL in order to output a frequency close to the SYSCLK (24.576MHz). The accuracy of audio output frequency will depend on the accuracy of PLL output.

The PLL transmit formula is:

$$F_{OUT} = (MCLK * (N+2)) / ((M+2) * (K+2)) \text{ \{Typical K=2\}}$$

**Table 8. AC-Link Clock Setting Table (Unit: MHz)**

MCLK	N	M	F <sub>VCO</sub>	K	F <sub>OUT</sub>
13	66	7	98.222	2	24.555
3.6864	78	1	98.304	2	24.576
2.048	94	0	— 98.304	2	24.576
4.096	70	1	98.304	2	24.576

After a Cold Reset, PLL related Registers are reset to default values, however, they are not reset to default values after a soft-reset (write Reg00). Firmware should not power down the PLL when the PLL output is used as Stereo\_SYSCLK.

*Note: The ALC5611 will only be enabled after an AC-Link Warm Reset.*

### 7.3.2. AC'97 Mode

For the AC-Link controller, the BIT\_CLK driven by PLL will only be enabled after a warm reset.

The sampling rate of the stereo ADC and stereo DAC can be configured separately and is controlled by Reg2C (stereo DAC) and Reg32 (stereo ADC).

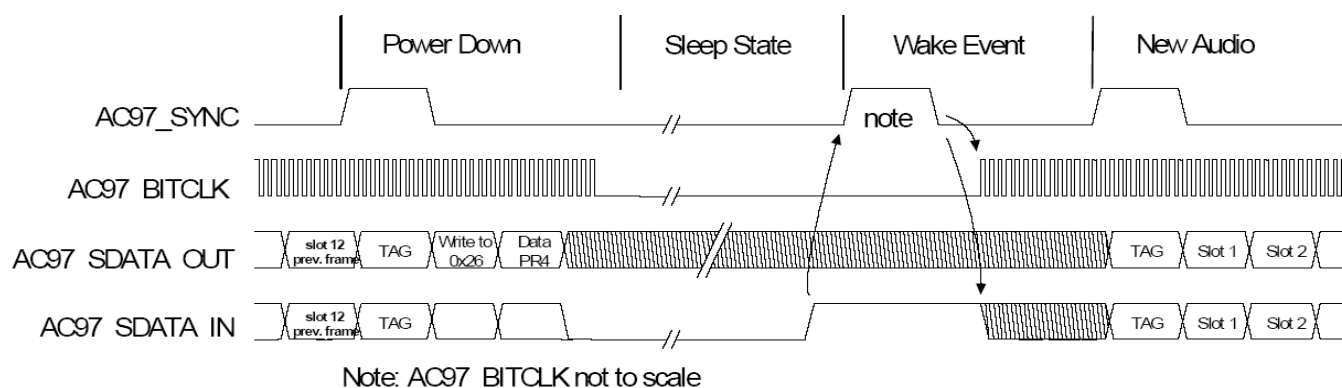
## 7.4. Digital Data Interface

### 7.4.1. AC-Link

When the ALC5611 takes serial data from the AC'97 controller, it samples SDATA\_OUT on the falling edge of BIT\_CLK. When the ALC5611 sends serial data to the AC'97 controller, it starts to drive SDATA\_IN on the rising edge of BIT\_CLK.

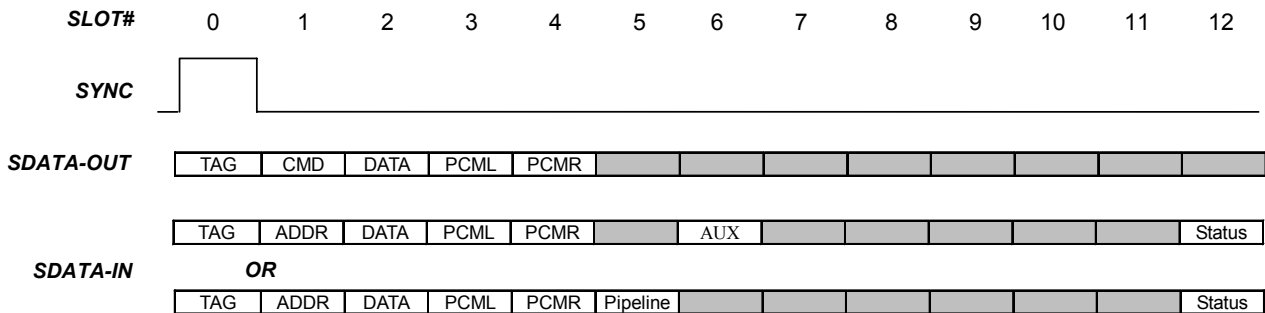
The ALC5611 will return any uninstalled bit or register read operations with 0. The ALC5611 also stuffs an unimplemented slot or bit with 0 in SDATA-IN. Note that AC-Link is MSB-justified.

See the 'Audio CODEC '97 Component Specification Revision 2.2' for detailed information.

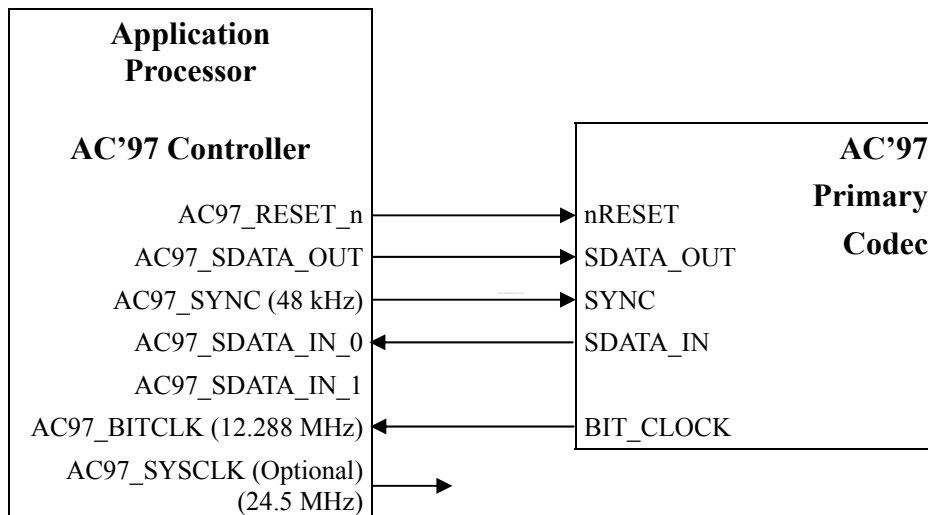


**Figure 4. AC-Link Wake Up Timing**

If wakeup control (Reg52 & Reg5E[1]) is enabled during Sleep state, the ALC5611 will assert SDATA\_IN and IRQOUT when interrupted.



**Figure 5. Default ALC5611 Slot Arrangement – CODEC ID Always 00**



**Figure 6. Controller and Codec Connection**

## **7.5. Audio Data Path**

### **7.5.1. Stereo ADC**

The stereo ADC is used for recording stereo sound.

The sample rate of the stereo ADC is independent of the stereo DAC sample rate.

In order to save power, the left and right ADC can be powered down separately by setting Reg3C [6], [7]. PR0=1 will disable both channels of the ADC.

The volume control of the stereo ADC is set via Reg12[11:7][4:0].

### **7.5.2. Stereo DAC**

The sample rate of the stereo DAC is controlled by Reg2C.

Reg0C[12:8][4:0] can be used to control the volume of DAC output.

### **7.5.3. Mixers**

The ALC5611 supports four mixers for all audio function requirements:

- Headphone mixer for 2 channels
- MONO mixer
- Speaker mixer
- ADC record mixer

#### **7.5.3.1 Headphone Mixer**

The headphone mixer is used to drive stereo output, including HP\_OUT\_L/R, SPK\_OUT\_L/R (SPK\_OUT\_LN/RN) and MONO\_OUT (MONO\_OUTN). The output of the headphone mixer can be input to the ADC record mixer.

The following signals can be mixed into the headphone mixer:

- LINE-IN\_L/R (Controlled by Reg0A)
- PHONEP/N (Controlled by Reg08)
- MIC1P/N and MIC2P/N (Controlled by Reg22 & Reg10)
- Stereo DAC output (Controlled by Reg0C)
- ADC record mixer output (Controlled by Reg12 & Reg14).

*Note: The headphone mixer can be powered down by setting Reg3C[5][4].*

### 7.5.3.2 *MONO Mixer*

The MONO mixer is used to drive MONO\_OUT (MONO\_OUTN) and SPK\_OUT\_L/R (SPK\_OUT\_LN/RN). The output of the MONO mixer can be input to the ADC record mixer. The output of the MONO mixer is two channels with the same signal.

The following signals can be mixed into the MONO mixer:

- LINE-IN\_L/R (Controlled by Reg0A)
- MIC1P/N and MIC2P/N (Controlled by Reg22 & Reg10)
- Stereo DAC output (Controlled by Reg0C)
- ADC record mixer output (Controlled by Reg12 & Reg14).

*Note: The MONO mixer can be powered down by setting Reg3C[2].*

### 7.5.3.3 *Speaker Mixer*

The speaker mixer is the same as the MONO mixer and is used to drive MONO\_OUT (MONO\_OUTN) and SPK\_OUT\_L/R (SPK\_OUT\_LN/RN). The output of the speaker mixer can be input to the ADC record mixer. The output of the speaker mixer is two channels with the same signal.

The following signals can be mixed into the speaker mixer:

- LINE-IN\_L/R (Controlled by Reg0A)
- PHONEP/N (Controlled by Reg08)
- MIC1P/N and MIC2P/N (Controlled by Reg22 & Reg10)
- Stereo DAC output (Controlled by Reg0C)

*Note: The speaker mixer can be powered down by setting Reg3C[3].*

### 7.5.3.4 *ADC Record Mixer*

The ADC record mixer is used to mix analog signals as input to the Stereo ADC for recording. Output of the ADC record mixer can be input to the headphone mixer, MONO mixer, and speaker mixer.

The following signals can be mixed into the ADC record mixer:

- LINE-IN\_L/R (Controlled by Reg0A)
- PHONEP/N (Controlled by Reg08)
- MIC1P/N and MIC2P/N (Controlled by Reg22 & Reg10)
- Headphone mixer output
- MONO mixer output
- Speaker mixer output

*Note: The ADC record mixer can be powered down by setting Reg3C[1][0].*

## 7.5.4. Analog Audio Input Path

The ALC5611 supports four Analog Audio Input paths:

- Line\_IN\_L/R
- PHONEP/N
- MIC1
- MIC2

### 7.5.4.1 Line Input

Line\_In\_L and Line\_In\_R provide 2-channel stereo single-ended input that can be mixed into the MONO mixer, Headphone mixer, Speaker mixer, or the ADC record mixer.

The Line\_In\_L/R volume and mute are controlled by Reg0A. Reg3E[7:6] can be used to power down Line\_In volume control.

### 7.5.4.2 Phone Input

PHONEP/N provides one-channel MONO differential or single-ended input configured by Reg08[13] that can be mixed into the ADC record mixer, or any analog output mixer except for the MONO mixer. PHONEP is main input when differential mode is disabled.

The PHONEP/N volume and mute are controlled by Reg08. Reg3E[5:4] can be used to power down the PHONEP/N volume control and mixer.

### 7.5.4.3 Microphone Input

MIC1P/N and MIC2P/N provide two-channel stereo differential or single-ended input via Reg10[12], [4], that can be mixed into the ADC record mixer, or any analog output mixer. MIC1P and MIC2P are main inputs when differential mode is disabled. MIC1N is pin-shared to AUX3 input.

The ALC5611 Microphone input boost provides 20/30/40dB boost, set by Reg22[11:10] (for MIC1), and by Reg22[9:8] (for MIC2). The MIC1/2 volume and mute are controlled by Reg0E.

For detailed power management of MIC1/2, Reg3E[3][2] can be used to power down the MIC1/2 volume control. Reg3E[1][0] can be used to power down MIC1/2 boost.

#### 7.5.4.4 *MIC1N/AUX3 and MICBIAS2/AUX4 Pin Sharing*

MIC1N is pin-shared with AUX3 input of AUX\_ADC. MICBIAS2 is pin-shared with AUX4 input of AUX\_ADC. The driver must set the related register as shown in Table 9.

**Table 9. Pin Sharing Configuration Table**

AUX3_mic1n_sharing	AUX4_micbias2_sharing	Reg76[0]: Aux_measure_sel	Reg76[7]: AUX_measure_en	Reg10[12]: micl_diff_ctrl	Reg3A[2]: pow_mic2_bias
MIC1N	AUX4	AUX4 (0'b)	-	-	Disable (0'b)
MIC1N	MICBIAS2	-	0'b	-	-
AUX3	AUX4	AUX3/AUX4 (1'b/0'b)	-	Disable (0'b)	Disable (0'b)
AUX3	MICBIAS2	AUX3 (1'b)	-	Disable (0'b)	-

### 7.5.5. Analog Audio Output Data Path

The ALC5611 supports three Analog Audio output paths:

- SPK\_OUT\_L/R
- HP\_OUT\_L/R
- MONO\_OUT

#### 7.5.5.1 *Speaker Output*

SPK\_OUT\_L/R provides two-channel differential output.

The SPK\_OUT\_L source is set in Reg1C[15:14]. Sources are shown below:

- Vmid
- Headphone left mixer
- Speaker mixer
- MONO mixer

The SPK\_OUT\_R source is set in Reg1C[12:11]. Sources are shown below:

- Vmid
- Headphone right mixer
- Speaker mixer
- MONO mixer



The ALC5611 speaker supports Class-AB and Class-D type amplifiers (set in Reg1C[13]:spk\_out\_sel). As the voltage of SPKVDD is usually higher than AVDD, the driver should set the Class-AB Vmid ratio in Reg40[5:3], and the Class-D Vmid ratio in Reg40[7:6] in order to extend the output level.

In Class-AB mode, for single stereo speaker solutions, SPK\_OUT\_R can select a different signal source (SPKR Volume output or SPKL Volume output by Reg1C[14]) but SPK\_OUT\_RN only outputs SPKR Volume Negative Output.

The SPK\_OUT\_L/R volume and mute are controlled by Reg02.

Reg3E[13:12]and Reg3E[9:8] can be used to power down SPK output.

Reg3C[14]: pow\_clsab is used to power down Class-AB output.

SPK\_OUT\_L/R supports the zero-cross detect function (enabled at Reg02[6][14]: sp\_l\_dezero/sp\_r\_dezero).

### 7.5.5.2 *Headphone Output*

HP\_OUT\_L/R provides two-channel single-ended output. The HP\_OUT\_L/R source is set in Reg1C[9][8]. Sources are shown below:

- Vmid
- Headphone mixer

The HP\_OUT\_L/R volume and mute are controlled by Reg04.

Reg3E[11]: pow\_hp\_l\_vol and Reg3E[10]: pow\_hp\_r\_vol can be used to power down the volume of HP output.

HP\_OUT supports the zero-cross detect function (enabled at Reg04[14][6]:hp\_l\_dezero/ hp\_r\_dezero).

### 7.5.5.3 *MONO Output*

MONO\_OUT provide one-channel differential or single-ended output configured by Reg08[15]. The MONO\_OUT source is set in Reg1C[7:6]. Sources are shown below:

- Vmid
- Headphone mixer (L+R)
- Speaker mixer
- MONO mixer

The MONO\_OUT volume and mute are controlled by Reg08.

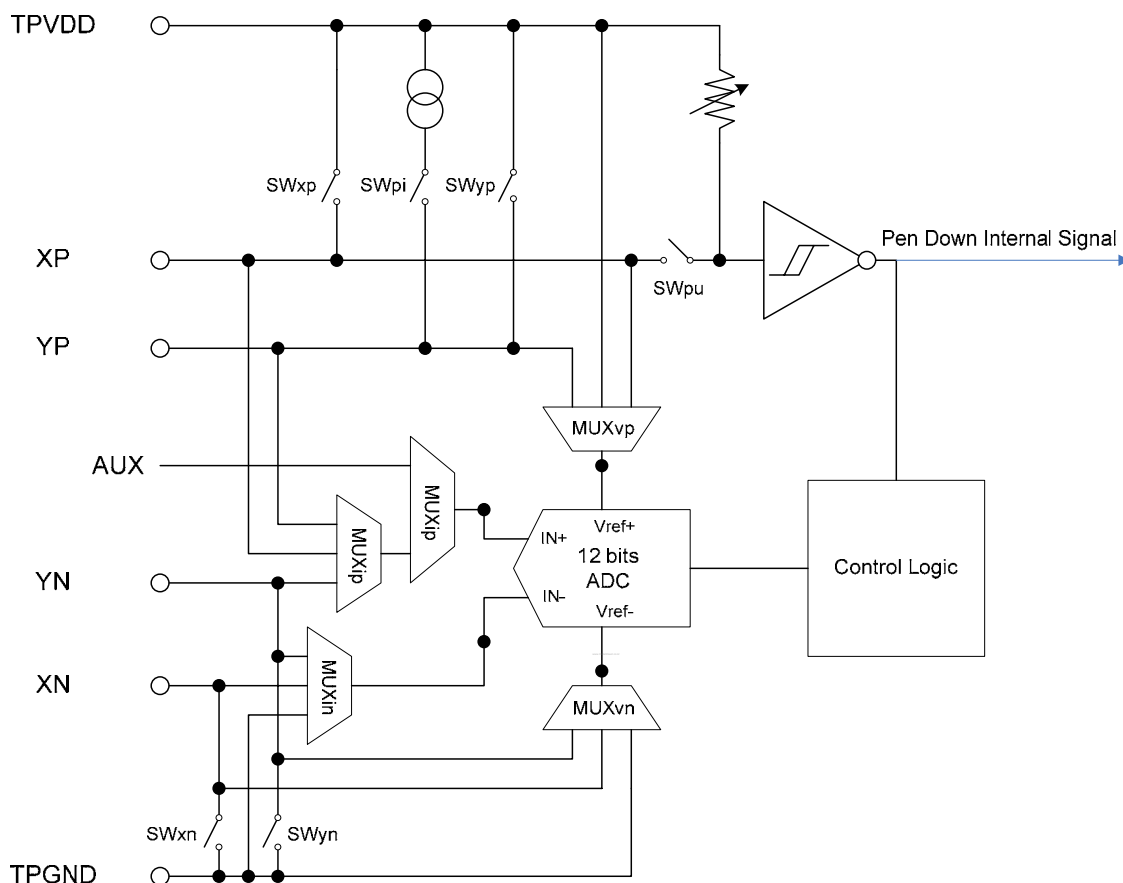
Reg3E[14]: pow\_MONO\_out\_vol can be used to power down the volume of MONO\_OUT.

MONO\_OUT supports the zero-cross detect function (enabled at Reg08[6]:MONO\_dezero).

## 7.6. Touch Panel Control

The ALC5611 provides 4-wire resistive touch panel control. X-position, Y-position, Pen-down detection, touch pressure, and AUX measurement are supported by using AUX\_ADC.

There are 2 modes within the touch panel measurement: Continuous mode (Reg76[14]=1), and polling mode (Reg76[14]=0).



**Figure 7. 4-Wire Resistive Touch Panel Circuit**

### Continuous Mode

The ALC5611 automatically initializes the measurement at the rate set in Reg74[1:0], and sends the measured data back to the AC'97 Controller. It is strongly recommended that the total measure time of one measure cycle (Delay time + measure time) not be longer than the measurement frame period (1/measurement rate).

### Polling Mode

In polling mode the AC'97 Controller starts each measurement by setting the measure item and writing Reg76[15]=1. The ALC5611 will clear the Reg76[15] after measurement is complete.

## 7.7. AVC Control

The Automatic Volume Control (AVC) function dynamically adjusts the input signal quantized by the ADC to an expected sound level by setting THmax and THmin.

When the average level of input signal is higher than THmax, the AVC will decrease the selected analog gain to attenuate the quantized Pulse Code Modulation (PCM) signal to a lower amplitude than THmax.

When the average level of input signal is lower than THmin, the AVC will increase the selected analog gain to amplify the input signal. The quantized Pulse Code Modulation (PCM) signal is then set higher than THmin. The quantized PCM has an average level between THmin and THmax.

The AVC reference source channel and target channel can be individually set by Index20[0] and Reg5E[13:12].

The AVC architecture is shown in Figure 8 below:

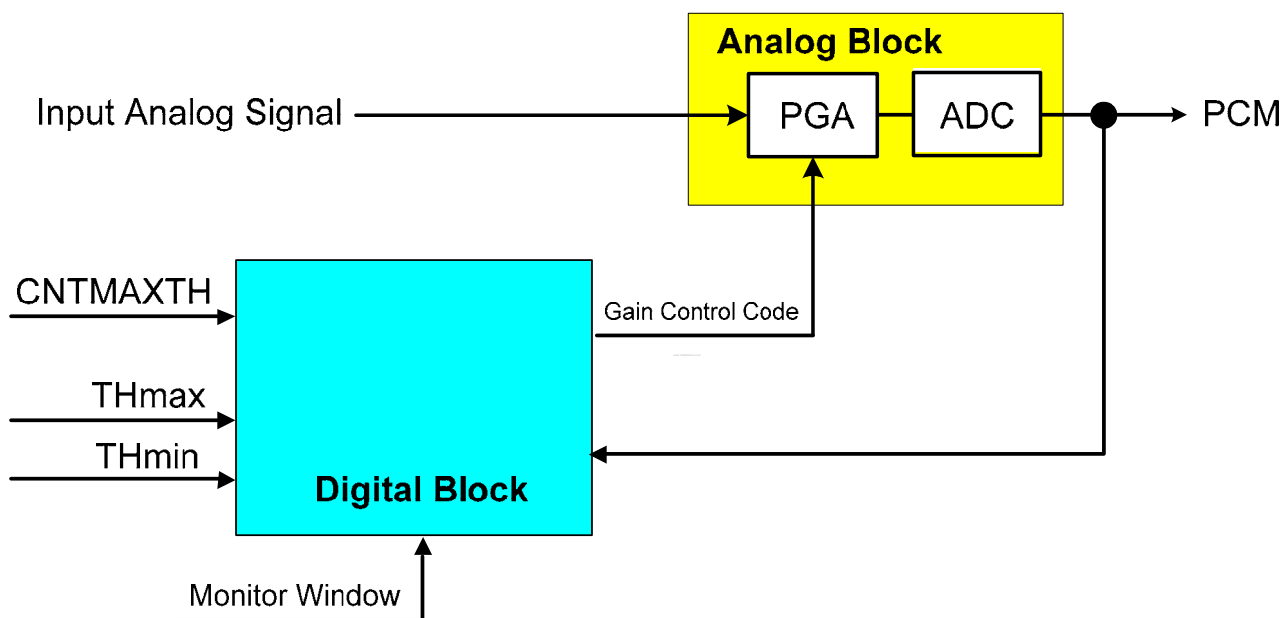


Figure 8. Auto Volume Control Block Diagram

## ***7.8. Hardware Sound Effects***

The Sound Effect block is composed of Pseudo Stereo, Spatial 3D and Equalizer blocks. The Pseudo Stereo block is used to convert a MONO source into virtualized stereo output. The Spatial 3D block is a surround sound generator with adjustable amplitude (Gain) and surround depth (Ratio). The Equalizer block can be used to compensate for speaker response, or to make environment sound effects, e.g., ‘Pub’, ‘Live’, ‘Rock’,... etc..

### **7.8.1. Equalizer Block**

The Equalizer block cascades 5 bands of equalizer to compensate for speaker response and to emulate environment sound. One high-pass filter cascaded in the front end is used to drop low frequency tone, which has a larger amplitude and may damage a mini speaker.

The high-pass filter can also be used to adjust Treble strength with gain control. A low-pass filter with gain control can adjust the Bass strength. Three bands of bi-quad bandpass filters are used to emulate environment sounds.

To avoid internal PCM data sample saturation, the digital volume control has up to 18dB of attenuation before the equalizer. A 0~+18dB digital gain after the equalizer is used to correct internal PCM data output to a suitable level.

### **7.8.2. Pseudo Stereo and Spatial 3D Sound**

There are two spatial effects in post-processing; the Pseudo-Stereo Effect + Spatial Effect, and the Stereo Expansion Effect. The Pseudo-Stereo Effect + Spatial Effect converts a MONO signal to a stereo signal by changing the phase and amplitude of the original signal followed by enhancing the spatial effect. The Stereo Expansion Effect enhances the spatial effect when the input signal is Stereo.

## ***7.9. Odd-Addressed Register Access***

The ALC5611 will return ‘0000h’ when odd-addressed and unimplemented registers are read.

## 7.10. Power Management

The ALC5611 supports a standard power down control register as defined in AC'97 (Reg26). More detailed Power Management control is supported in Reg 3C & 3E. Each particular block will only be active when both Reg26 and Reg3C/3E are set to 'Enable'.

### 7.10.1. Sleep Mode

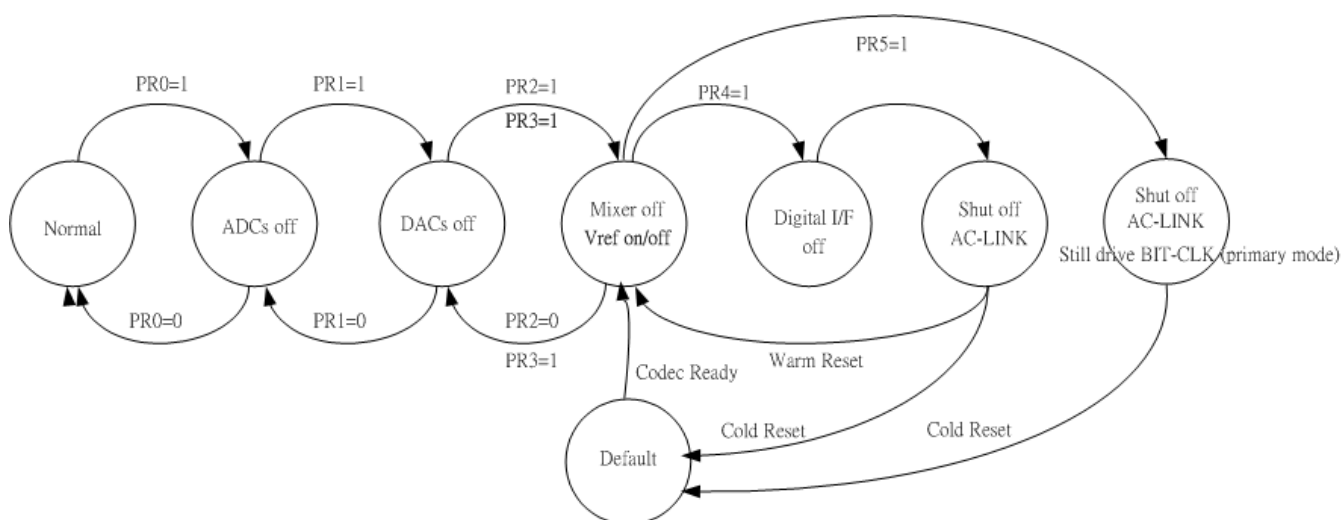
When PR4 (Reg26) is set, the ALC5611 will enter Sleep Mode. Before entering sleep mode, the driver can set other control bits to save power according to system requirements.

The following functions should be kept operating during sleep mode:

- Pen-down Detection
- GPIO and Interrupts
- Analog to analog path when control registers Reg 3C & 3E are enabled

There are two methods to wake the ALC5611 from Sleep mode

- Warm Reset and Cold Reset from AC Link
- Wake-up from GPIO (configured as Input) and Internal event signal (pen-down, over-temperature) when the wake-up bit is set at Reg52.



**Figure 9. Example of ALC5611 Power-Down/Power-Up Flow**

## 7.11. GPIO and Interrupt

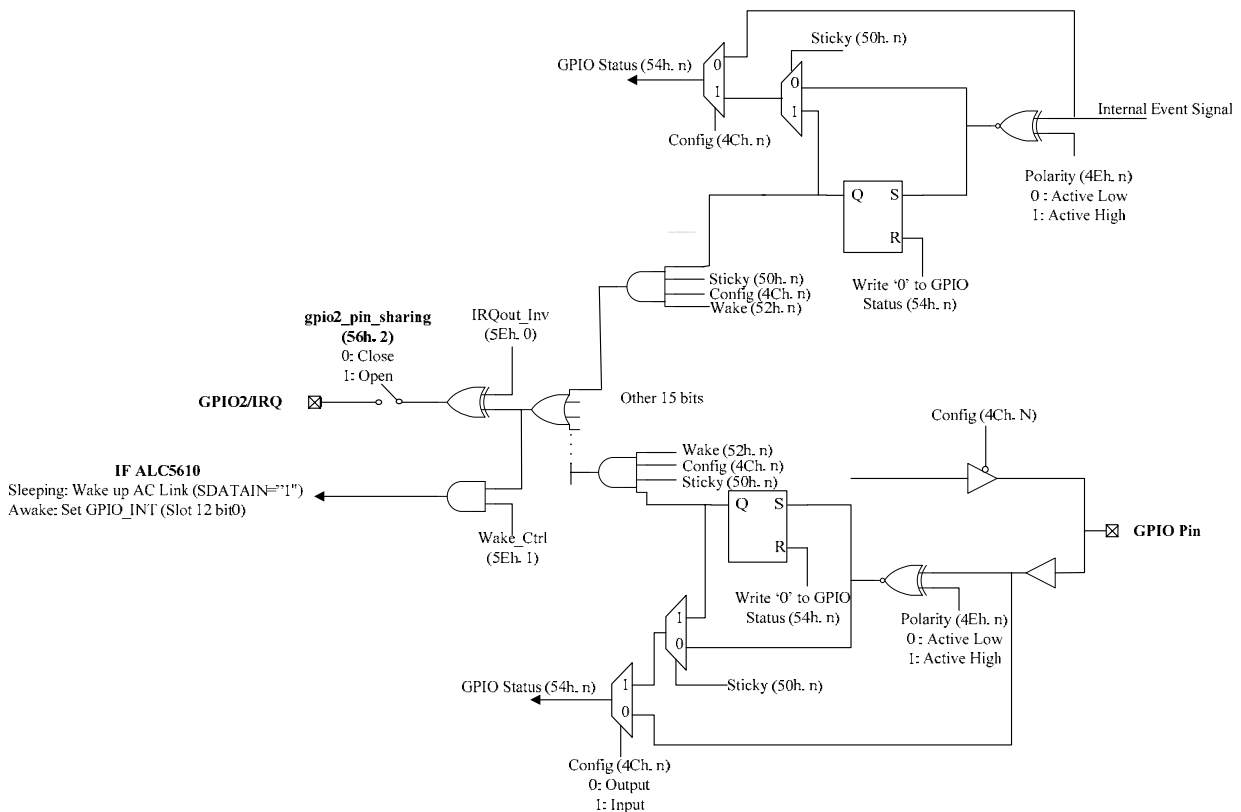
The ALC5611 supports up to five GPIOs. Each GPIO can be configured as Input/Output by Reg4C. When GPIOs are configured as Input, the status will be indicated in Reg54 and Slot 12. When GPIOs are configured as Output, Reg5C is used to drive GPIOs to High (1b) or Low (0b). The status can be read in Reg54.

Interrupt request (IRQ) function can be configured as:

- Sticky by setting Reg50
- Changed polarity by setting Reg4E
- Wake-up by setting Reg52

The wake-up function will drive SDATA\_In 'high' when the AC-Link is in sleep mode, and set GPIO\_INT (Slot12 bit0) when the AC-Link is awake. The wake up function can only be enabled when Wake-up control (Reg5E[1])=1. The driver can write each bit of Reg54=1 to clear each IRQ status flag.

GPIO pin2 can be configured and pin-shared with IRQ\_Output by setting Reg56.



**Figure 10. GPIO Implementation**

There are some internal events (pen-down, over-temperature, MICBIAS short detect) where GPIOs can be an interrupt source. GPIO Internal event application is located in Reg4C, Reg4E, Reg50, Reg52, and Reg54.

## 8. Mixer Registers List

Accessing odd numbered registers, or reading unimplemented registers, will return a 0.

### 8.1. Reg-00h: Reset

Default: 59B4h

**Table 10. Reg-00h: Reset**

Name	Bits	Read/Write	Reset State	Description
Reserved	15	R	0'h	Reserved. Read as 0
REG-00_b14_b10	14:10	R	16'h	SE[4:0]=10110b
REG-00_b9	9	R	0'h	No Support for 20-Bit ADC
REG-00_b8	8	R	1'h	Supports 16-Bit ADC
REG-00_b7	7	R	1'h	Supports 16-Bit DAC
REG-00_b6	6	R	0'h	No Support for 18-Bit DAC
REG-00_b5	5	R	1'h	Support for Loudness
REG-00_b4	4	R	1'h	Headphone Output Support
Reserved	3	R	0'h	Reserved
REG-00_b2	2	R	1'h	Supports EQ Control
Reserved	1	R	0'h	Reserved. Read as 0
REG-00_b0	0	R	0'h	Dedicated MIC PCM input is not supported. Can be for touch panel ADC use

*Note: Writes to this register will reset all registers to their default values except PLL related Register. The written data will be ignored.*

### 8.2. Reg-02h: Speaker Output Volume

Default: 8080h

**Table 11. Reg-02h: Speaker Output Volume**

Name	Bits	Read/Write	Reset State	Description
sp_l_mute	15	RW	1'h	Mute Left Control 0: On                    1: Mute Left Channel (-∞dB)
sp_l_dezero	14	RW	0'h	Left Zero-Cross Detector Control 0: Disable            1: Enable
Reserved	13	R	0'h	Reserved. Read as 0
sp_l_vol	12:8	RW	0'h	Speaker Output Left Volume (SPKL[4:0]) in 1.5dB Steps
sp_r_mute	7	RW	1'h	Mute Right Control 0: On                    1: Mute Right Channel (-∞dB)
sp_r_dezero	6	RW	0'h	Right Zero-Cross Detector Control 0: Disable            1: Enable
Reserved	5	R	0'h	Reserved. Read as 0
sp_r_vol	4:0	RW	0'h	Speaker Output Right Volume (SPKR[4:0]) in 1.5dB Steps

*Note: For SPKR/SPKL, 00h: 0dB attenuation                    1Fh: 46.5dB attenuation*

### 8.3. Reg-04h: Headphone Output Volume

Default: 8080h

**Table 12. Reg-04h: Headphone Output Volume**

Name	Bits	Read/Write	Reset State	Description
hp_l_mute	15	RW	1'h	Mute Left Control 0: On                           1: Mute Left Channel (-∞dB)
hp_l_dezero	14	RW	0'h	Left Zero-Cross Detector Control 0: Disable                   1: Enable
Reserved	13	R	0'h	Reserved. Read as 0
hp_l_vol	12:8	RW	0'h	Headphone Output Left Volume (HPL[4:0]) in 1.5dB Steps
hp_r_mute	7	RW	1'h	Mute Right Control 0: On                           1: Mute Right Channel (-∞dB)
hp_r_dezero	6	RW	0'h	Right Zero-Cross Detector Control 0: Disable                   1: Enable
Reserved	5	R	0'h	Reserved. Read as 0
hp_r_vol	4:0	RW	0'h	Headphone Output Right Volume (HPR[4:0]) in 1.5dB Steps

Note: For HPR/HPL, 00h: 0dB attenuation

1Fh: 46.5dB attenuation

### 8.4. Reg-08h: Phone Input/MONO Output Volume

Default: C880h

**Table 13. Reg-08h: Phone Input/MONO Output Volume**

Name	Bits	Read/Write	Reset State	Description
phone2hp_mute	15	RW	1'h	Mute Phone Input to Headphone Mixer Control 0: On                           1: Mute (-∞dB)
phone2spk_mute	14	RW	1'h	Mute Phone Input to Speaker Mixer Control 0: On                           1: Mute (-∞dB)
phone_diff_ctrl	13	RW	0'h	Phone Differential Input Control 0: Disable                   1: Enable
phone_vol	12:8	RW	8'h	Phone Input Volume (PV[4:0]) in 1.5dB Steps (not to ADC)
MONO_mute	7	RW	1'h	Mute MONO Output Control 0: On                           1: Mute (-∞dB)
MONO_dezero	6	RW	0'h	Zero-Cross Detector Control 0: Disable                   1: Enable
MONO_diff_ctrl	5	RW	0'h	MONO Output Differential Control 0: Disable (SE)         1: Enable (BTL)
MONO_vol	4:0	RW	0'h	MONO Output Master Volume (MOV[4:0]) in 1.5dB Steps

Note: For MOV, 00h: 0dB attenuation

1Fh: 46.5dB attenuation

For PV, 00h: +12dB gain

08h: 0dB attenuation

1Fh: 34.5dB attenuation



## 8.5. Reg-0Ah: LINE\_IN Volume

Default: E808h

**Table 14. Reg-0Ah: LINE\_IN Volume**

Name	Bits	Read/Write	Reset State	Description
li2hp_mute	15	RW	1'h	Mute Volume Output to Headphone Mixer Control 0: On                                   1: Mute
li2spk_mute	14	RW	1'h	Mute Volume Output to Speaker Mixer Control 0: On                                   1: Mute
li2MONO_mute	13	RW	1'h	Mute Volume Output to MONO Mixer Control 0: On                                   1: Mute
li_l_vol	12:8	RW	08'h	LINE_IN Left Volume (NLV[4:0]) in 1.5dB Steps
Reserved	7:5	R	0'h	Reserved
li_r_vol	4:0	RW	8'h	LINE_IN Right Volume (NRV[4:0]) in 1.5dB Steps

*Note: For NRV/NLV, 00h: +12dB gain                                   08h: 0dB attenuation                                   1Fh: 34.5dB attenuation*

## 8.6. Reg-0Ch: STEREO DAC Volume

Default: E808h

**Table 15. Reg-0Ch: STEREO DAC Volume**

Name	Bits	Read/Write	Reset State	Description
dac2hp_mute	15	RW	1'h	Mute Volume Output to Headphone Mixer Control 0: On                                   1: Mute (-∞dB)
dac2spk_mute	14	RW	1'h	Mute Volume Output to Speaker Mixer Control 0: On                                   1: Mute (-∞dB)
dac2mono_mute	13	RW	1'h	Mute Volume Output to MONO Mixer Control 0: On                                   1: Mute (-∞dB)
dac_l_vol	12:8	RW	08'h	Left DAC Volume (PLV[4:0]) in 1.5dB Steps
Reserved	7:5	R	0'h	Reserved
dac_r_vol	4:0	RW	8'h	Right DAC Volume (PRV[4:0]) in 1.5dB Steps

*Note: For PRV/PLV, 00h: +12dB gain                                   08h: 0dB attenuation                                   1Fh: 34.5dB attenuation*

## 8.7. Reg-0Eh: MIC Volume

Default: 0808h

**Table 16. Reg-0Eh: MIC Volume**

Name	Bits	Read/Write	Reset State	Description
Reserved	15:13	R	0'h	Reserved
mic1_vol	12:8	RW	08'h	MIC1 Volume (M1V[4:0]) in 1.5dB Steps
Reserved	7:5	R	0'h	Reserved
mic2_vol	4:0	RW	8'h	MIC2 Volume (M2V[4:0]) in 1.5dB Steps

*Note: For M2V/M1V, 00h: +12dB gain                                   08h: 0dB attenuation                                   1Fh: 34.5dB attenuation*

## 8.8. Reg-10h: MIC Routing Control

Default: E0E0h

**Table 17. Reg-10h: MIC Routing Control**

Name	Bits	Read/Write	Reset State	Description
mic12hp_mute	15	RW	1'h	Mute MIC1 Volume Output to Headphone Mixer 0: On                   1: Mute
mic12spk_mute	14	RW	1'h	Mute MIC1 Volume Output to Speaker Mixer 0: On                   1: Mute
mic12MONO_mute	13	RW	1'h	Mute MIC1 Volume Output to MONO Mixer 0: On                   1: Mute
mic1_diff_ctrl	12	RW	0'h	MIC1 Differential Input Control 0: Disable            1: Enable
Reserved	11:8	R	0'h	Reserved
mic22hp_mute	7	RW	1'h	Mute MIC2 Volume Output to Headphone Mixer 0: On                   1: Mute
mic22spk_mute	6	RW	1'h	Mute MIC2 Volume Output to Speaker Mixer 0: On                   1: Mute
mic22MONO_mute	5	RW	1'h	Mute MIC2 Volume Output to MONO Mixer 0: On                   1: Mute
mic2_diff_ctrl	4	RW	0'h	MIC2 Differential Input Control 0: Disable            1: Enable
Reserved	3:0	R	0'h	Reserved

## 8.9. Reg-12h: ADC Record Gain

Default: F58Bh

**Table 18. Reg-12h: ADC Record Gain**

Name	Bits	Read/Write	Reset State	Description
adc2hp_l_mute	15	RW	1'h	Mute Left Gain Output to Headphone Mixer Control 0: On                   1: Mute (-∞dB)
adc2hp_r_mute	14	RW	1'h	Mute Right Gain Output to Headphone Mixer Control 0: On                   1: Mute (-∞dB)
adc2MONO_l_mute	13	RW	1'h	Mute Left Gain Output to MONO Mixer Control 0: On                   1: Mute (-∞dB)
adc2MONO_r_mute	12	RW	1'h	Mute Right Gain Output to MONO Mixer Control 0: On                   1: Mute (-∞dB)
adc_l_vol	11:7	RW	0B'h	ADC Record Gain Left Channel (LRG[4:0]) in 1.5dB Steps 00h: -16.5dB attenuation 0Bh: 0dB gain        1Fh: 30dB gain
adc_l_dezero	6	RW	0'h	ADC_L Zero-Cross Detector Control 0: Disable            1: Enable
adc_r_dezero	5	RW	0'h	ADC_R Zero-Cross Detector Control 0: Disable            1: Enable
adc_r_vol	4:0	RW	0B'h	ADC Record Gain Right Channel (RRG[4:0]) in 1.5dB Steps 00h: -16.5dB attenuation 0Bh: 0dB gain        1Fh: 30dB gain

## 8.10. Reg-14h: ADC Record Mixer Control

Default: 7F7Fh

**Table 19. Reg-14h: ADC Record Mixer Control**

Name	Bits	Read/Write	Reset State	Description
Reserved	15	R	0'h	Reserved
adrec_l_mute	14:8	RW	7F'h	Left Mixer Mute Control 0: On 1: Mute (-∞dB) Bit 14: MIC1 Bit 13: MIC2 Bit 12: LINE_IN_L Bit 11: PHONE Bit 10: Headphone Mixer Left Channel Bit 9: Speaker Mixer Bit 8: MONO Mixer
Reserved	7	R	0'h	Reserved
adrec_r_mute	6:0	RW	7F'h	Right Mixer Mute Control 0: On 1: Mute (-∞dB) Bit 6: MIC1 Bit 5: MIC2 Bit 4: LINE_IN_R Bit 3: PHONE Bit 2: Headphone Mixer Right Channel Bit 1: Speaker Mixer Bit 0: MONO Mixer

## 8.11. Reg-1Ch: Output Mixer Control

Default: 0000h

**Table 20. Reg-1Ch: Output Mixer Control**

Name	Bits	Read/Write	Reset State	Description
spk_l_vol_in_sel	15:14	RW	0'h	SPKL Volume Input Select 00: VMID (No input)      01: HP Left Mixer 10: Speaker mixer        11: MONO
spk_l_out_sel	13	RW	0'h	SPKL and SPKR Output Select 0: Class-AB                1: Class-D
spk_r_vol_in_sel	12:11	RW	0'h	SPKR Volume Input Select 00: VMID (No input)      01: HP Right Mixer 10: Speaker Mixer        11: MONO
Reserved	10	R	0'h	Reserved

Name	Bits	Read/Write	Reset State	Description
hp_l_in_sel	9	RW	0'h	HPL Volume Input Select 0: VMID (No input)      1: HP Left Mixer
hp_r_in_sel	8	RW	0'h	HPR Volume Input Select 0: VMID (No input)      1: HP Right Mixer
MONO_in_sel	7:6	RW	0'h	MONO Volume Input Select 00: VMID (No input)    01: HP Left + Right Mixer 10: Speaker Mixer      11: MONO Mixer
Reserved	5	R	0'h	Reserved
clab_amp_source_sel	4	RW	0'h	In Class-AB Mode SPK_OUT_R Output Amplifier Source Select 0: SPKR Volume Output 1: SPKL Volume Output <i>Note: SPK_OUT_RN: SPKR Volume Negative Output.</i>
Reserved	3:0	R	0'h	Reserved

## 8.12. Reg-22h: Microphone Control

Default: 0000h

**Table 21. Reg-22h: Microphone Control**

Name	Bits	Read/Write	Reset State	Description
Reserved	15:12	R	0'h	Reserved
mic1_boost_ctrl	11:10	RW	0'h	MIC1 Boost Control 00: Bypass              01: +20dB 10: +30dB              11: +40dB
mic2_boost_ctrl	9:8	RW	0'h	MIC2 Boost Control 00: Bypass              01: +20dB 10: +30dB              11: +40dB
Reserved	7:6	R	0'h	Reserved. Read as 0
mic1_bias_voltage_ctrl	5	RW	0'h	MICBIAS1 Output Voltage Control 0: 0.9*AVDD            1: 0.75*AVDD
mic2_bias_voltage_ctrl	4	RW	0'h	MICBIAS2 Output Voltage Control 0: 0.9*AVDD            1: 0.75*AVDD
Reserved	2:3	R	0'h	Reserved. Read as 0
mic_bias_threshold	1:0	RW	0'h	MICBIAS1/2 Short Current Detector Threshold 00: 600μA              01: 1200μA 1x: 1800μA

### 8.13. Reg-26h: Power Down Control/Status

Default: EF00h

**Table 22. Reg-26h: Power Down Control/Status**

Name	Bits	Read/Write	Reset State	Description
ac_pr7	15	RW	1'h	PR7 0: Normal 1: Power down Speaker Amplifier
ac_pr6	14	RW	1'h	PR6 0: Normal 1: Power down Headphone Out and MONO Out
ac_pr5	13	RW	1'h	PR5 0: Normal 1: Disable internal clock of AC'97 (Without PLL)
ac_pr4	12	RW	0'h	PR4 0: Normal 1: Power down AC-Link <i>Note: Though this bit is read as 1, write 1 to power down the AC-Link.</i>
ac_pr3	11	RW	1'h	PR3 0: Normal 1: Power down Mixer (Vref/Vrefout off)
ac_pr2	10	RW	1'h	PR2 0: Normal 1: Power down Mixer (Vref/Vrefout are still on)
ac_pr1	9	RW	1'h	PR1 0: Normal 1: Power down STEREO DAC
ac_pr0	8	RW	1'h	PR0 0: Normal 1: Power down STEREO ADC, and input MUX
Reserved	7:4	R	0'h	Reserved. Read as 0
vref_status	3	R	0'h	Vref Status 1: Vref is up to normal level 0: Not yet up to normal level
analog_mixer_status	2	R	0'h	Analog Mixer Status 1: Ready 0: Not yet ready
dac_status	1	R	0'h	DAC Status 1: Ready 0: Not yet ready (Inverse of PR1)
adc_status	0	R	0'h	ADC Status 1: Ready 0: Not yet ready (Inverse of PR0)

**Table 23. Truth Table for Power Down Mode (PD=Power Down)**

	ADC	DAC	Mixer	Vref	ACLINK	Int CLK	HP-OUT	MONO-OUT	SPK-OUT
PR0=1	PD	-	-	-	-	-	-	-	-
PR1=1	-	PD	-	-	-	-	-	-	-
PR2=1	-	-	PD	-	-	-	PD	-	-
PR3=1	PD	PD	PD	PD	-	-	PD	-	-
PR4=1	PD	PD	-	-	PD	-	-	-	-
PR5=1	PD	PD	-	-	PD	PD	-	-	-
PR6=1	-	-	-	-	-	-	PD	PD	-
PR7=1	-	-	-	-	-	-	-	-	PD

## 8.14. Reg-2Ah: Tone Control

Default: 0000h

**Table 24. Reg-2Ah: Tone Control**

Name	Bits	Read/Write	Reset State	Description
Reserved	15:1	R	0'h	Reserved
ac_src_en	0	RW	0'h	Enable Variable Rate Audio Control 0: Off                      1: On

## 8.15. Reg-2Ch: AC'97 Stereo DAC Rate/DPE Rate

Default: BB80h

**Table 25. Reg-2Ch: AC'97 Stereo DAC Rate/DPE Rate**

Name	Bits	Read/Write	Reset State	Description
dac_sample_rate	15:0	RW	BB80'h	FOSR[15:0] Output Sampling Rate

The ALC5611 supports the following PC99/PC2001 design guide sampling rates.

**Table 26. PC99/PC2001 Design Guide Sampling Rates**

Sampling Rate	FOSR[15:0]
8000	1F40h
11025	2B11h
12000	2EE0
16000	3E80h
22050	5622h
24000	5DC0
32000	7D00h
44100	AC44h
48000	BB80h

When ac\_src\_en=0 (VRA is disabled), any non-zero value in this register will be forced to BB80h.

## 8.16. Reg-32h: AC'97 Stereo ADC Rate

Default: BB80h

**Table 27. Reg-32h: AC'97 Stereo ADC Rate**

Name	Bits	Read/Write	Reset State	Description
adc_sample_rate	15:0	RW	BB80'h	IISR[15:0] Output Sampling Rate.

The ALC5611 supports the following PC99/PC2001 design guide sampling rates.

**Table 28. PC99/PC2001 Design Guide Sampling Rates**

Sampling Rate	IISR[15:0]
8000	1F40h
11025	2B11h
12000	2EE0
16000	3E80h
22050	5622h
24000	5DC0
32000	7D00h
44100	AC44h
48000	BB80h

## 8.17. Reg-3Ah: Power Management Addition 1

Default: 0000h

**Table 29. Reg-3Ah: Power Management Addition 1**

Name	Bits	Read/Write	Reset State	Description
depop_MONOoutb	15	RW	0'h	Depop of MONO Out 0: Enable (De-pop Enable) 1: Disable (De-pop Disable)
depop_hp_outb	14	RW	0'h	Depop of HP Out 0: Enable (De-pop Enable) 1: Disable (De-pop Disable)
pow_zcd	13	RW	0'h	All Zero-Cross Detect Power down 0: Disable 1: Enable
ip_en	12	RW	0'h	Pressure Measurement Source Current Enable 0: Disable 1: Enable
Pow_zcd_timo_out_en	11	RW	0'h	Zero Cross Time Out Enable 0: Disable 1: Enable
Reserved	10:6	RW	0'h	Reserved
pow_mic1_bias_det_ctrl	5	RW	0'h	MICBIAS1 Short Current Detector Control 0: Disable 1: Enable
pow_mic2_bias_det_ctrl	4	RW	0'h	MICBIAS2 Short Current Detector Control 0: Disable 1: Enable
pow_mic1_bias	3	RW	0'h	0: Disable 1: Enable microphone1 bias
pow_mic2_bias	2	RW	0'h	0: Disable 1: Enable microphone2 bias
pow_main_bias	1	RW	0'h	0: Disable 1: Enable Main bias of the ALC5611
pow_dac_ref	0	RW	0'h	0: Disable 1: Enable ALL DAC reference of the ALC5611



## 8.18. Reg-3Ch: Power Management Addition 2

Default: 0000h

**Table 30. Reg-3Ch: Power Management Addition 2**

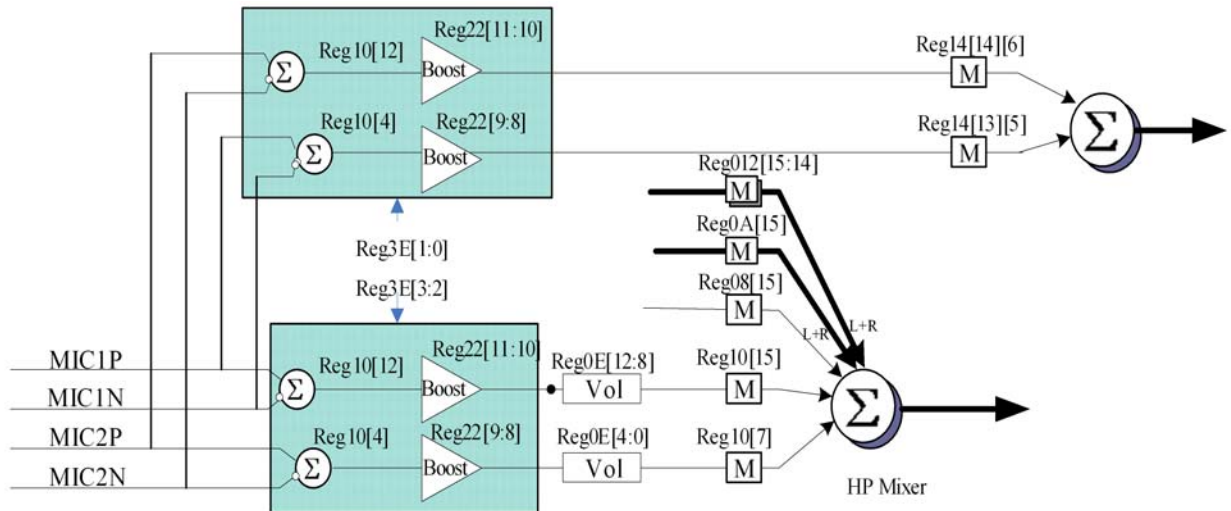
Name	Bits	Read/Write	Reset State	Description
pow_thermal	15	RW	0'h	Thermal Detect (Temp Sensor) 0: Disable            1: Enable
pow_clsab	14	RW	0'h	Class_AB Power (All) 0: Disable            1: Enable
pow_vref	13	RW	0'h	VREF of All Analog Circuits 0: Disable            1: Enable
pow_pll	12	RW	0'h	PLL 0: Disable            1: Enable PLL
pow_tp_adc	11	RW	0'h	Touch Panel and AUX_ADC 0: Disable            1: Enable
Reserved	10	RW	0'h	Reserved
pow_dac_l	9	RW	0'h	Left Stereo DAC Filter Clock 0: Disable            1: Enable
pow_dac_r	8	RW	0'h	Right Stereo DAC Filter Clock 0: Disable            1: Enable
pow_adc_l	7	RW	0'h	Left Stereo ADC Filter Clock and Input Gain 0: Disable            1: Enable
pow_adc_r	6	RW	0'h	Right Stereo ADC Filter Clock and Input Gain 0: Disable            1: Enable
pow_hp_l	5	RW	0'h	Left Headphone Mixer 0: Disable            1: Enable
pow_hp_r	4	RW	0'h	Right Headphone Mixer 0: Disable            1: Enable
pow_spk_mixer	3	RW	0'h	Speaker Mixer 0: Disable            1: Enable
pow_MONO_mixer	2	RW	0'h	MONO Mixer 0: Disable            1: Enable
pow_adc_rec_l_mixer	1	RW	0'h	Left ADC Record Mixer 0: Disable            1: Enable
pow_adc_rec_r_mixer	0	RW	0'h	Right ADC Record Mixer 0: Disable            1: Enable

## 8.19. Reg-3Eh: Power Management Addition 3

Default: 0000h

**Table 31. Reg-3Eh: Power Management Addition 3**

Name	Bits	Read/Write	Reset State	Description
Reserved	15	R	0'h	Reserved
pow_MONO_out_vol	14	RW	0'h	MONO_OUT Volume Control (Amp) 0: Disable      1: Enable
pow_spk_outln	13	RW	0'h	SPK_OUTLN Output (Enable Class-AB & Class-D) 0: Disable      1: Enable
pow_spk_outrn	12	RW	0'h	SPK_OUTRN Output (Enable Class-AB & Class-D) 0: Disable      1: Enable
pow_hp_l_vol	11	RW	0'h	HP_OUT_L Volume Control (Amp) 0: Disable      1: Enable
pow_hp_r_vol	10	RW	0'h	HP_OUT_R Volume Control (Amp) 0: Disable      1: Enable
pow_spk_l	9	RW	0'h	SPK_OUT_L Output (Enable Class-AB & Class-D) 0: Disable      1: Enable
pow_spk_r	8	RW	0'h	SPK_OUT_R Output (Enable Class-AB & Class-D) 0: Disable      1: Enable
pow_li_l_vol	7	RW	0'h	LINE_IN Left Volume Control 0: Disable      1: Enable
pow_li_r_vol	6	RW	0'h	LINE_IN Right Volume Control 0: Disable      1: Enable
pow_phone_vol	5	RW	0'h	PHONE Volume Control 0: Disable      1: Enable
pow_phone_admixer	4	RW	0'h	PHONE AD Mixer 0: Disable      1: Enable
pow_mic1_vol	3	RW	0'h	MIC1 Volume Control 0: Disable      1: Enable
pow_mic2_vol	2	RW	0'h	MIC2 Volume Control 0: Disable      1: Enable
pow_mic1_admixer	1	RW	0'h	MIC1 AD Mixer and Boost 0: Disable      1: Enable
pow_mic2_admixer	0	RW	0'h	MIC2 AD Mixer and Boost 0: Disable      1: Enable



**Figure 11. Power Control to MIC Input**

## 8.20. Reg-40h: General Purpose Control Register 1

Default: 0428h

**Table 32. Reg-40h: General Purpose Control Register 1**

Name	Bits	Read/Write	Reset State	Description
sel_sysclk	15	RW	0'h	Clock Source MUX Control 0: MCLK 1: PLL Output
Reserved	14:10	RW	1'h	Reserved
hp_amp_ctrl	9:8	RW	0'h	Headphone Amplifier $V_{MID}$ Ratio Control (Output Gain Control) 00: 1 01: 1.25 1x: 1.5
spk_ampD_ctrl	7:6	RW	0'h	Speaker Class-D Amplifier $V_{MID}$ Ratio Control (Output Gain Control) 00: 1.75 Vdd 01: 1.5 Vdd 10: 1.25 Vdd 11: 1.0 Vdd
spk_ampAB_ctrl	5:3	RW	5'h	Speaker Class-AB Amplifier $V_{MID}$ Ratio Control (Output Gain Control) 000: 2.25 Vdd 001: 2.00 Vdd 010: 1.75 Vdd 011: 1.5 Vdd 100: 1.25 Vdd 101: 1 Vdd Others: Not allowed
Reserved	2:0	RW	0'h	Reserved

## 8.21. Reg-42h: General Purpose Control Register 2

Default: 0000h

**Table 33. Reg-42h: General Purpose Control Register 2**

Name	Bits	Read/Write	Reset State	Description
Reserved	15:14	RW	0'h	Reserved
se_btl_clsab	13	RW	0'b	Single-Ended & BTL of SPK_Class-AB Selection 0: Differential Mode 1: Single-ended Mode
Reserved	12:1	RW	0'h	Reserved
pll_pre_div	0	RW	0'b	PLL Pre-Divider 0b: ÷1 1b: ÷2

## 8.22. Reg-44h: PLL Control

Default: 0000h

**Table 34. Reg-44h: PLL Control**

Name	Bits	Read/Write	Reset State	Description
pll_n_code	15:8	RW	00'h	N[7:0] Code for Analog PLL 00000000: Div 2 00000001: Div 3 ..... 11111111: Div 257
pll_m_bypass	7	RW	0'h	Bypass PLL M 0b: No bypass 1b: Bypass
pll_k_code	6:4	RW	0'h	K[2:0] Code for Analog PLL 000: Div 2 001: Div 3 ..... 111: Div 9
pll_m_code	3:0	RW	0'h	M[3:0] Code for Analog PLL 0000: Div 2 0001: Div 3 ..... 1111: Div 17

Note: The PLL transmit formula is  $F_{OUT} = (MCLK * (N+2)) / ((M+2) * (K+2))$  {Typical K=2}.

### 8.22.1. AC-Link PLL Clock Setting Table (Unit: MHz)

**Table 35. AC-Link PLL Clock Setting Table (Unit: MHz)**

MCLK	N	M	F <sub>VCO</sub>	K	F <sub>OUT</sub>
13	66	7	98.222	2	24.555
3.6864	78	1	98.304	2	24.576
2.048	94	0	98.304	2	24.576
4.096	70	1	98.304	2	24.576

Note: PLL will only be enabled after a warm reset of the AC-Link.

### 8.23. Reg-4Ch: GPIO Pin Configuration

Default: 2E3Eh

**Table 36. Reg-4Ch: GPIO Pin Configuration**

Name	Bits	Read/Write	Reset State	Description
Reserved	15:14	R	00'b	Reserved
pendown_conf	13	RW	1'h	Pen-down Detect Status Source Configuration 0: Bypass                      1: Normal
Reserved	12	R	0'b	Reserved
over_temp_conf	11	RW	1'h	Over-Temperature Status Source Configuration 0: Bypass                      1: Normal
mic1_short_det_conf	10	RW	1'h	MICBIAS1 Short Current Status Source Configuration 0: Bypass                      1: Normal
mic2_short_det_conf	9	RW	1'h	MICBIAS2 Short Current Status Source Configuration 0: Bypass                      1: Normal
Reserved	8:6	R	0'h	Reserved
gpio5_conf	5	RW	1'h	GPIO5 Pin Configuration 0: Output                      1: Input
gpio4_conf	4	RW	1'h	GPIO4 Pin Configuration 0: Output                      1: Input
gpio3_conf	3	RW	1'h	GPIO3 Pin Configuration 0: Output                      1: Input
gpio2_conf	2	RW	1'h	GPIO2 Pin Configuration 0: Output                      1: Input
gpio1_conf	1	RW	1'h	GPIO1 Pin Configuration 0: Output                      1: Input
Reserved	0	R	0'h	Reserved. Read as 0

## 8.24. Reg-4Eh: GPIO Pin Polarity

Default: 2E3Eh

**Table 37. Reg-4Eh: GPIO Pin Polarity**

Name	Bits	Read/Write	Reset State	Description
Reserved	15:14	R	00'b	Reserved
pendown_polarity	13	RW	1'h	Pen-Down Detect Polarity 0: Low Active            1: High Active
Reserved	12	R	0'b	Reserved
over_temp_polarity	11	RW	1'h	Over-Temperature Polarity 0: Low Active            1: High Active
mic1_short_det_polarity	10	RW	1'h	MICBIAS1 Short Current Detect Polarity 0: Low Active            1: High Active
mic2_short_det_polarity	9	RW	1'h	MICBIAS2 Short Current Detect Polarity 0: Low Active            1: High Active
Reserved	8:6	R	0'h	Reserved. Read as 0
gpio5_polarity	5	RW	1'h	GPIO Pin Polarity 0: Low Active            1: High Active
gpio4_polarity	4	RW	1'h	GPIO Pin Polarity 0: Low Active            1: High Active
gpio3_polarity	3	RW	1'h	GPIO Pin Polarity 0: Low Active            1: High Active
gpio2_polarity	2	RW	1'h	GPIO Pin Polarity 0: Low Active            1: High Active
gpio1_polarity	1	RW	1'h	GPIO Pin Polarity 0: Low Active            1: High Active
Reserved	0	R	0'h	Reserved. Read as 0

## 8.25. Reg-50h: GPIO Pin Sticky

Default: 0000h

**Table 38. Reg-50h: GPIO Pin Sticky**

Name	Bits	Read/Write	Reset State	Description
Reserved	15:14	R	00'b	Reserved
pendown_sticky_En	13	RW	0'h	Pen-Down Detect Sticky Enable 0: Not sticky            1: Sticky
Reserved	12	R	0'b	Reserved
over_temp_sticky_En	11	RW	0'h	Over-Temperature Sticky Enable 0: Not sticky            1: Sticky
mic1_short_det_sticky_En	10	RW	0'h	MICBIAS1 Short Current Detect Sticky Enable 0: Not sticky            1: Sticky
mic2_short_det_sticky_En	9	RW	0'h	MICBIAS2 Short Current Detect Sticky Enable 0: Not sticky            1: Sticky

Name	Bits	Read/Write	Reset State	Description
Reserved	8:6	R	0'h	Reserved. Read as 0
gpio5_sticky_En	5	RW	0'h	GPIO5 Pin Sticky Enable 0: Not sticky                   1: Sticky
gpio4_sticky_En	4	RW	0'h	GPIO4 Pin Sticky Enable 0: Not sticky                   1: Sticky
gpio3_sticky_En	3	RW	0'h	GPIO3 Pin Sticky Enable 0: Not sticky                   1: Sticky
gpio2_sticky_En	2	RW	0'h	GPIO2 Pin Sticky Enable 0: Not sticky                   1: Sticky
gpio1_sticky_En	1	RW	0'h	GPIO1 Pin Sticky Enable 0: Not sticky                   1: Sticky
Reserved	0	R	0'h	Reserved. Read as 0

## 8.26. Reg-52h: GPIO Pin Wake-Up

Default: 0000h

**Table 39. Reg-52h: GPIO Pin Wake-Up**

Name	Bits	Read/Write	Reset State	Description
Reserved	15:14	R	00'b	Reserved
pendown_wakeup_en	13	RW	0'h	Pen-Down Detect Wake-Up Enable 0: No wake-up                   1: Wake Up
Reserved	12	R	0'b	Reserved
over_temp_wakeup_en	11	RW	0'h	Over-Temperature Wake-Up Enable 0: No wake-up                   1: Wake Up
mic1_short_det_wakeup_en	10	RW	0'h	MICBIAS1 Short Current Detect Wake-Up Enable 0: No wake-up                   1: Wake Up
mic2_short_det_wakeup_en	9	RW	0'h	MICBIAS2 Short Current Detect Wake-Up Enable 0: No wake-up                   1: Wake Up
Reserved	8:6	R	0'h	Reserved. Read as 0
gpio5_wakeup_en	5	RW	0'h	GPIO5 Pin Wake-Up Enable 0: No wake-up                   1: Wake Up
gpio4_wakeup_en	4	RW	0'h	GPIO4 Pin Wake-Up Enable 0: No wake-up                   1: Wake Up
gpio3_wakeup_en	3	RW	0'h	GPIO3 Pin Wake-Up Enable 0: No wake-up                   1: Wake Up
gpio2_wakeup_en	2	RW	0'h	GPIO2 Pin Wake-Up Enable 0: No wake-up                   1: Wake Up
gpio1_wakeup_en	1	RW	0'h	GPIO1 Pin Wake-Up Enable 0: No wake-up                   1: Wake Up
Reserved	0	R	0'h	Reserved. Read as 0

## 8.27. Reg-54h: GPIO Pin Status

Default: 003Ah

**Table 40. Reg-54h: GPIO Pin Status**

Name	Bits	Read/Write	Reset State	Description
Reserved	15:14	R	00'b	Reserved
pendown_status	13	R	0'h	Pen-Down Detect Status Read: Return status Write: Writing '0' clears the sticky bit
Reserved	12	R	0'b	Reserved
over_temp_status	11	R	0'h	Over-Temperature Status Read: Return status Write: Writing '0' clears the sticky bit
mic1_short_det_status	10	R	0'h	MICBIAS1 Short Current Detect Status Read: Return status Write: Writing '0' clears the sticky bit
mic2_short_det_status	9	R	0'h	MICBIAS2 Short Current Detect Status Read: Return status Write: Writing '0' clears the sticky bit
Reserved	8:6	R	0'h	Reserved. Read as 0
gpio5_status	5	R	1'h	GPIO5 Pin Status Read: Return status of each GPIO pin Write: Writing '0' clears the sticky bit
gpio4_status	4	R	1'h	GPIO4 Pin Status Read: Return status of each GPIO pin Write: Writing '0' clears the sticky bit
gpio3_status	3	R	1'h	GPIO3 Pin Status Read: Return status of each GPIO pin Write: Writing '0' clears the sticky bit
gpio2_status	2	R	1'h	GPIO2 Pin Status Read: Return status of each GPIO pin Write: Writing '0' clears the sticky bit
gpio1_status	1	R	1'h	GPIO1 Pin Status Read: Return status of each GPIO pin Write: Writing '0' clears the sticky bit
Reserved	0	R	0'h	Reserved. Read as 0

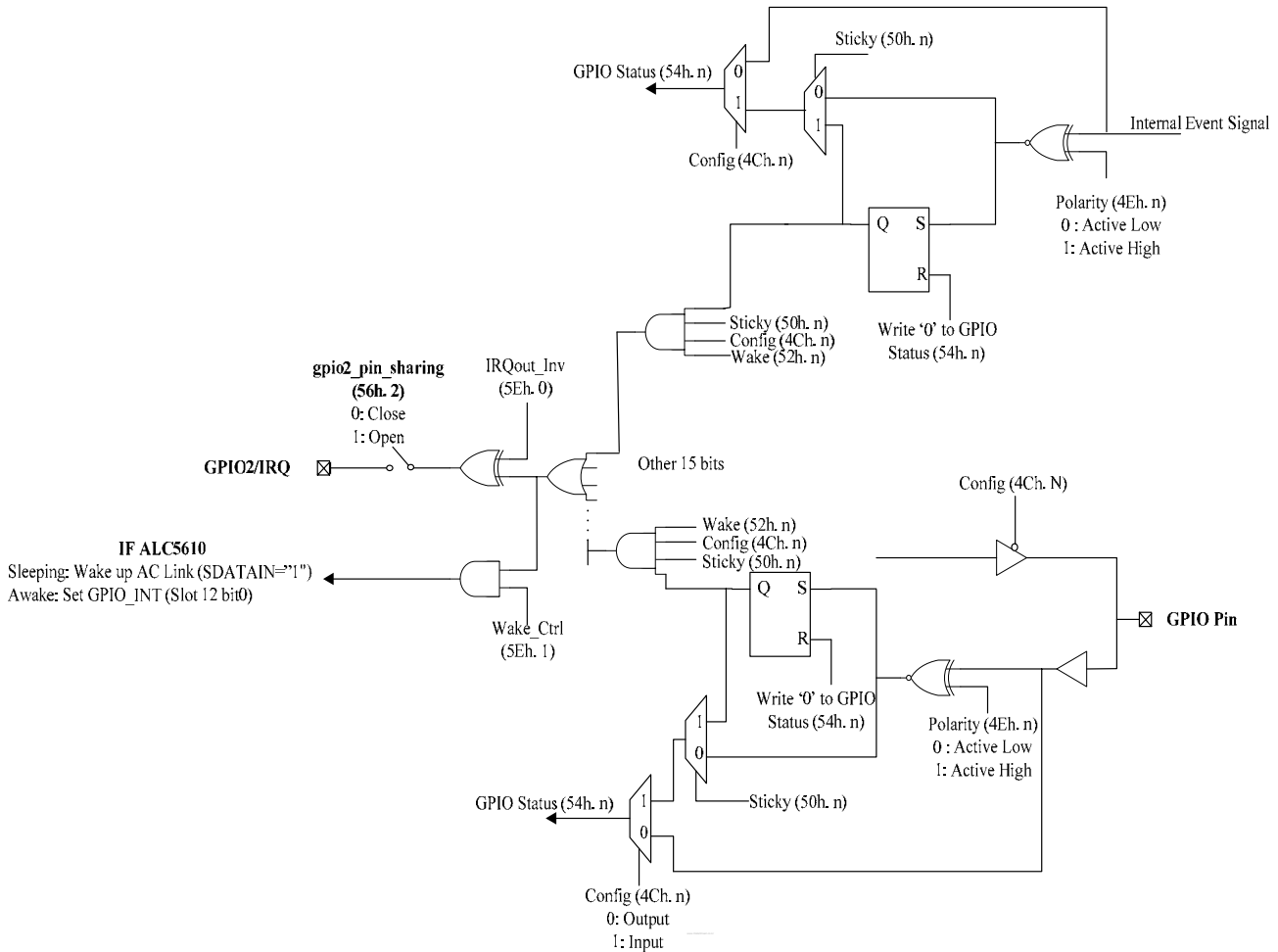
## 8.28. Reg-56h: Pin Sharing

Default: 0000h

**Table 41. Reg-56h: Pin Sharing**

Name	Bits	Read/Write	Reset State	Description
Reserved	15:3	R	0'h	Reserved
gpio2_pin_sharing	2	RW	0'h	GPIO2 Pin Sharing 0: IRQ_Out                      1: GPIO enable
Reserved	1:0	R	0'h	Reserved




**Figure 12. GPIO and IRQ Logic**
**Table 42. GPIO and IRQ Logic**

GPIO Bit Reg54[15:1]	SLOT 12 Bit	Source	Description
1	5	GPIO Pin	GPIO1 Input Status
2	6	GPIO Pin	GPIO2
3	7	GPIO Pin	GPIO3
4	8	GPIO Pin	GPIO4
5	9	GPIO Pin	GPIO5
6	10	-	Unused
7	11	-	Unused
8	12	-	Unused
9	13	VGPIO	MICBIAS2 Short Current Detect
10	14	VGPIO	MICBIAS1 Short Current Detect
11	15	VGPIO	Over-Temperature
12	16	-	Unused
13	17	VGPIO	Pen-Down Detect
14	18	-	Unused
15	19	-	Unused

## 8.29. Reg-58h: Over-Temp/Current Status

Default: 0CFFh

**Table 43. Reg-58h: Over-Temp/Current Status**

Name	Bits	Read/Write	Reset State	Description
Reserved	15:12	R	0000'h	Reserved
ovt_hp_status	11	R	1'h	Headphone Amp Over-Temperature 0: Normal                      1: Over-temperature
ovt_MONO_status	10	R	1'h	MONO Amp Over-Temperature 0: Normal                      1: Over-temperature
ovc_micbias1_status	9	R	0'h	MICBIAS1 Over-Current 0: Normal                      1: Over-current
ovc_micbias2_status	8	R	0'h	MICBIAS2 Over-Current 0: Normal                      1: Over-current
rp_depoc_status	7	R	1'h	RP Channel Depoc Status 0: Depoc ready                1: Depoc finished
rn_depoc_status	6	R	1'h	RN Channel Depoc Status 0: Depoc ready                1: Depoc finished
lp_depoc_status	5	R	1'h	LP Channel Depoc Status 0: Depoc ready                1: Depoc finished
ln_depoc_status	4	R	1'h	LN Channel Depoc Status 0: Depoc ready                1: Depoc finished
ovt_rp_status	3	R	1'h	RP Channel Temperature Sensor Status 0: Normal                      1: Over-temperature
ovt_rn_status	2	R	1'h	RN Channel Temperature Sensor Status 0: Normal                      1: Over-temperature
ovt_lp_status	1	R	1'h	LP Channel Temperature Sensor Status 0: Normal                      1: Over-temperature
ovt_ln_status	0	R	1'h	LN Channel Temperature Sensor Status 0: Normal                      1: Over-temperature

## 8.30. Reg-5Ch: GPIO\_Output Pin Control

Default: 0000h

**Table 44. Reg-5Ch: GPIO\_Output Pin Control**

Name	Bits	Read/Write	Reset State	Description
Reserved	15:6	R	0000'h	Reserved
gpio5_out_status	5	RW	0'h	GPIO5 Output Pin Control 0b: Drive Low                1b: Drive High
gpio4_out_status	4	RW	0'h	GPIO4 Output Pin Control 0b: Drive Low                1b: Drive High
gpio3_out_status	3	RW	0'h	GPIO3 Output Pin Control 0b: Drive Low                1b: Drive High
gpio2_out_status	2	RW	0'h	GPIO2 Output Pin Control 0b: Drive Low                1b: Drive High
gpio1_out_status	1	RW	0'h	GPIO1 Output Pin Control 0b: Drive Low                1b: Drive High
Reserved	0	R	0'h	Reserved. Read as 0

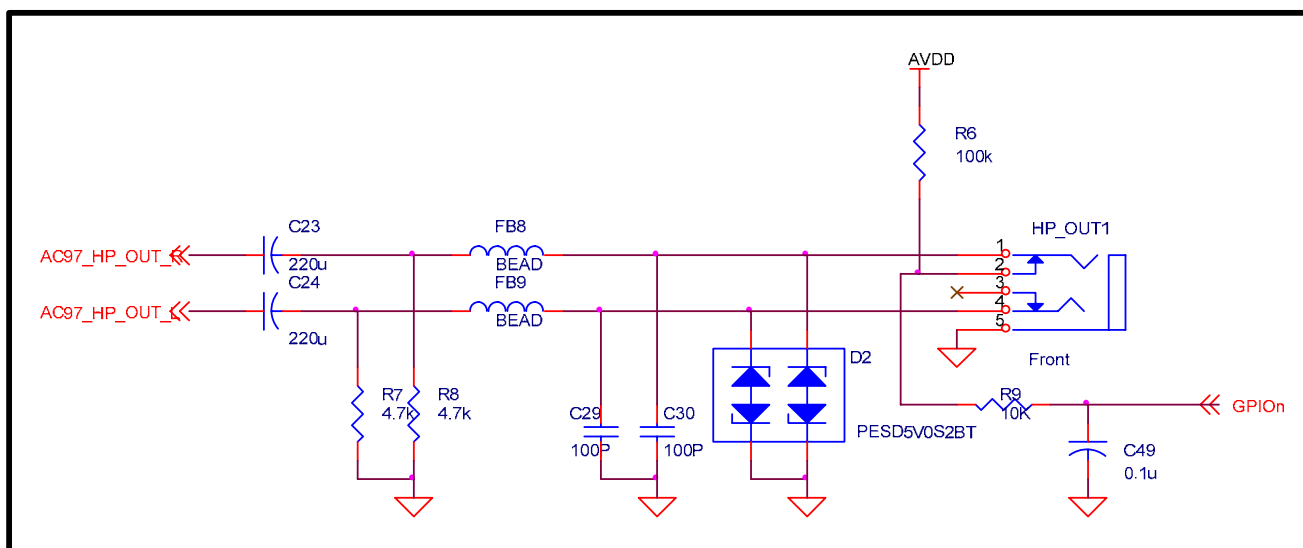
### 8.31. Reg-5Eh: MISC Control

Default: 0000h

**Table 45. Reg-5Eh: MISC Control**

Name	Bits	Read/Write	Reset State	Description
en_vref_fast	15	RW	0'b	Enable Fast Vref 0: Enable fast Vref 1: Disable fast Vref <i>Note: To improve PSRR, en_vref_fast should be disabled before playback/record.</i>
clsab_amp_sel	14	RW	0'b	Class-AB Output Amplifier Select 0: Strong Amp 1: Weak Amp <i>Note: Strong Amp, SPKVDD: 3.0V~5V and Set index44[8:6]=100'b. Weak Amp, SPKVDD: 2.3V~5V and set index44[8:6]=000'b.</i>
AVC_target_sel	13:12	RW	0'b	AVC Target Select 00: Reserved (No AVC)      01: R Channel 10: L Channel                11: Both channel
thermal_shutdown_en	11	RW	0'b	Thermal Shutdown Enable 0: Disable                      1: Enable
reset_pendown_sel	10	RW	0'b	Reset/Pen-Down Selection 0: Reset Input 1: Pen-down Output <i>Note: Output Reg78[15] status as pen-down signal when Reset_Pendown_sel=1. Sequence: 1. Set the GPIO of the controller as output and set the ALC5611 as Reset_Input. 2. After Reset, Set the GPIO of the controller as Input and set the ALC5611 as Pendown_Output. 3. Enable the GPIO of the controller to receive INT. 4. After the controller Received INT, the controller disables INT and starts to check AUXADC. 5. Pen-up will be reported by Reg78[15].</i>
Reserved	9:7	RW	0'h	Reserved
main_dac_l_mute	6	RW	0'h	Mute Main DAC Left Input 0: On                              1: Mute (-∞dB)
main_dac_r_mute	5	RW	0'h	Mute Main DAC Right Input 0: On                              1: Mute (-∞dB)
Reserved	4:2	RW	0'h	Reserved
gpio_wakeup_ctrl	1	RW	0'h	GPIO wakeup Control 0: Disable                      1: Enable
irqout_inv_ctrl	0	RW	0'h	IRQOUT Inverter Control 0: Normal                      1: Invert

The Jack-insert-detect pull up resistor is implemented via an external circuit (see Figure 13, below).



**Figure 13. Jack-Insert-Detect Pull Up Resistor Implemented via an External Circuit**

## 8.32. Reg-68h: Pseudo Stereo and Spatial Effect Block Control

Default: 0053h

**Table 46. Reg-68h: Pseudo Stereo and Spatial Effect Block Control**

Name	Bits	Read/Write	Reset State	Description
spatial_ctrl_enable	15	RW	0'b	Spatial Enable 0b: Disable (Clear internal state) 1b: Enable
apf_en	14	RW	0'h	Enable All Pass Filter APF(z) (EN-APF) 0: Disable (Bypass) and reset. 1: Enable all pass filters. The coefficient a1 is loaded from apf_parm_a1[7:0]
pseudo_stereo_en	13	RW	0'h	Enable Pseudo Stereo Block (EN-PSB) 0: Disabled 1: Enabled
en_3d	12	RW	0'h	Enable Stereo Expansion Block (EN-SEB) 0: Disable 1: Enabled. Load 3D Ratio from ratio_parm_3d and 3D Gain from gain_parm_3d
Reserved	11:8	-	0'h	Reserved
gain_parm_3d	7:6	RW	1'h	3D Gain Parameter (SEGn) 00: Gain=1.0                      01: Gain=1.5 10: Gain=2.0                      11: Reserved

Name	Bits	Read/Write	Reset State	Description
ratio_parm_3d	5:4	RW	1'h	3D Ratio Parameter (DPn) 00: Ratio=0.0            01: Ratio=0.66 10: Ratio=1.0           11: Reserved
Reserved	3:2	-	0'h	Reserved
apf_parm_a1	1:0	RW	3'h	All Pass Filter Parameter 00: Disable 01: Enable for 32kHz sample rate or lower 10: Enable for 44.1kHz sample rate 11: Enable for 48kHz sample rate

*Note: Writes to SEGn and DPn will be ignored when the Spatial effect control bit is enabled. This means individual Spatial coefficients cannot be modified when Spatial is enabled.*

### 8.33. Reg-6Ah: Index Address

Default: 0000h

**Table 47. Reg-6Ah: Index Address**

Name	Bits	Read/Write	Reset State	Description
Reserved	15:7	R	0'h	Reserved
index_addr	6:0	RW	0'h	Index Address

### 8.34. Reg-6Ch: Index Data

Default: 0000h

**Table 48. Reg-6Ch: Index Data**

Name	Bits	Read/Write	Reset State	Description
index_data	15:0	RW	0'h	Index Data

### 8.35. Reg-6Eh: EQ Status

Default: 0000h

**Table 49. Reg-6Eh: EQ Status**

Name	Bits	Read/Write	Reset State	Description
Reserved	15:5	R	0'h	Reserved
eq_hpf_status	4	R	0'h	EQ High-Pass Filter (HPF) Status 0: Normal 1: Overflow. This bit is set if overflow has occurred. Write 1 to clear.
eq_bpf3_status	3	R	0'h	EQ Band-3 (BP3) Status 0: Normal 1: Overflow. This bit is set if overflow has occurred. Write 1 to clear.
eq_bpf2_status	2	R	0'h	EQ Band-2 (BP2) Status 0: Normal 1: Overflow. This bit is set if overflow has occurred. Write 1 to clear.
eq_bpf1_status	1	R	0'h	EQ Band-1 (BP1) Status 0: Normal 1: Overflow. This bit is set if overflow has occurred. Write 1 to clear.
eq_lpf_status	0	R	0'h	EQ Low-Pass Filter (LPF) Status 0: Normal 1: Overflow. This bit is set if overflow has occurred. Write 1 to clear.

### 8.36. Index-00h: EQ Band-0 Coefficient (LP0: a1)

Default: 0000h

**Table 50. Index-00h: EQ Band-0 Coefficient (LP0: a1)**

Bit	Type	Function
15:0	RW	2's complement in 3.13 formats (The range is from -4~3.99, the a1 should be in -2 ~ 1.99)

Note: For low pass filter for Bass control – LP0 has filter coefficient a1 and gain Ho must be set (see Table 51).

### 8.37. Index-01h: EQ Band-0 Gain (LP0: Ho)

Default: 0000h

**Table 51. Index-01h: EQ Band-0 Gain (LP0: Ho)**

Bit	Type	Function
15:0	RW	2's complement in 3.13 format (The range is from -4~3.99, the Ho should be in -4 ~ 3.99)

### ***8.38. Index-02h: EQ Band-1 Coefficient (BP1: a1)***

Default: 0000h

**Table 52. Index-02h: EQ Band-1 Coefficient (BP1: a1)**

Bit	Type	Function
15:0	RW	2's complement in 3.13 format (The range is from -4~3.99, the a1 should be in -2 ~ 1.99)

### ***8.39. Index-03h: EQ Band-1 Coefficient (BP1: a2)***

Default: 0000h

**Table 53. Index-03h: EQ Band-1 Coefficient (BP1: a2)**

Bit	Type	Function
15:0	RW	2's complement in 3.13 format (The range is from -4~3.99, the a1 should be in -2 ~ 1.99)

### ***8.40. Index-04h: EQ Band-1 Gain (BP1: Ho)***

Default: 0000h

**Table 54. Index-04h: EQ Band-1 Gain (BP1: Ho)**

Bit	Type	Function
15:0	RW	2's complement in 3.13 format (The range is from -4~3.99, the Ho should be in -4 ~ 3.99)

### ***8.41. Index-05h: EQ Band-2 Coefficient (BP2: a1)***

Default: 0000h

**Table 55. Index-05h: EQ Band-2 Coefficient (BP2: a1)**

Bit	Type	Function
15:0	RW	2's complement in 3.13 format (The range is from -4~3.99, the a1 should be in -2 ~ 1.99)

### ***8.42. Index-06h: EQ Band-2 Coefficient (BP2: a2)***

Default: 0000h

**Table 56. Index-06h: EQ Band-2 Coefficient (BP2: a2)**

Bit	Type	Function
15:0	RW	2's complement in 3.13 format (The range is from -4~3.99, the a2 should be in -2 ~ 1.99)

### ***8.43. Index-07h: EQ Band-2 Gain (BP2: Ho)***

Default: 0000h

**Table 57. Index-07h: EQ Band-2 Gain (BP2: Ho)**

Bit	Type	Function
15:0	RW	2's complement in 3.13 format (The range is from -4~3.99, the Ho should be in -4 ~ 3.99)

### ***8.44. Index-08h: EQ Band-3 Coefficient (BP3: a1)***

Default: 0000h

**Table 58. Index-08h: EQ Band-3 Coefficient (BP3: a1)**

Bit	Type	Function
15:0	RW	2's complement in 3.13 format (The range is from -4~3.99, the a1 should be in -2 ~ 1.99)

### ***8.45. Index-09h: EQ Band-3 Coefficient (BP3: a2)***

Default: 0000h

**Table 59. Index-09h: EQ Band-3 Coefficient (BP3: a2)**

Bit	Type	Function
15:0	RW	2's complement in 3.13 format (The range is from -4~3.99, the a2 should be in -2 ~ 1.99)

### ***8.46. Index-0Ah: EQ Band-3 Gain (BP3: Ho)***

Default: 0000h

**Table 60. Index-0Ah: EQ Band-3 Gain (BP3: Ho)**

Bit	Type	Function
15:0	RW	2's complement in 3.13 format (The range is from -4~3.99, the Ho should be in -4 ~ 3.99)

### ***8.47. Index-0Bh: EQ Band-4 Coefficient (HPF: a1)***

Default: 0000h

**Table 61. Index-0Bh: EQ Band-4 Coefficient (HPF: a1)**

Bit	Type	Function
15:0	RW	2's complement in 3.13 format (The range is from -4~3.99, the a1 should be in -2 ~ 1.99)



### 8.48. Index-0Ch: EQ Band-4 Gain (HPF: Ho)

Default: 0000h

**Table 62. Index-0Ch: EQ Band-4 Gain (HPF: Ho)**

Bit	Type	Function
15:0	RW	2's complement in 3.13 format (The range is from -4~3.99, the Ho should be in -2 ~ 1.99)

### 8.49. Index-10h: EQ Control and Status Register

Default: 0000h

**Table 63. Index-10h: EQ Control and Status Register**

Bit	Type	Function
15	RW	EQ Block Control 0: Disable 1: Enable
14:5	-	Reserved
4	RW	EQ High-Pass Filter (HPF) Control 0: Disabled (bypass) and reset 1: Enabled
3	RW	EQ Band-3 (BP3) Control 0: Disabled and reset 1: Enabled
2	RW	EQ Band-2 (BP2) Control 0: Disabled and reset 1: Enabled
1	RW	EQ Band-1 (BP1) Control 0: Disabled and reset 1: Enabled
0	RW	EQ Low-Pass Filter (LPF) Control 0: Disabled and reset 1: Enabled

*Note: Individual EQ coefficients cannot be modified when EQ is enabled.*

### 8.50. Index-11h: EQ Input Volume Control

Default: 0000h

**Table 64. Index-11h: EQ Input Volume Control**

Bit	Type	Function
15:2	-	Reserved
1:0	RW	7-Bit Volume Unsigned Ratio EQIn-VOL-LR 00b: 0dB 01b: -6dB 10b: -12dB 11b: -18dB

## 8.51. Index-12h: EQ Output Volume Control

Default: 0001h

**Table 65. Index-12h: EQ Output Volume Control**

Bit	Type	Function
15:3	-	Reserved
2:0	RW	7-Bit Volume Unsigned Ratio EQOut-VOL-LR 000b: -3dB                      001b: 0dB 010b: 3dB                      011b: 6dB 100b: 9dB                      101b: 12dB 110b: 15dB                    111b: 18dB

## 8.52. Index-20h: Auto Volume Control Register 0

Default: 0050h

**Table 66. Index-20h: Auto Volume Control Register 0**

Bit	Type	Function
15	RW	Select the Controlled Gain Block for AVC (Default: 00b) 0: Disable AVC 1: Enable AVC to control ADC gain
14:8	-	Reserved
7:3	RW	Monitor Window Control (Unit: 2 <sup>(n+1)</sup> samples) (Default: 01010b) 00000b: 2 <sup>(1)</sup> sample 00001b: 2 <sup>(2)</sup> samples 00010b: 2 <sup>(3)</sup> samples ... 10000b: 2 <sup>(17)</sup> samples ... Others: Reserved. Maximum n=16 <i>Note: The Monitor Window can only be changed after soft-reset when AVC is enabled.</i>
2:1	-	Reserved
0	RW	AVC Reference Channel Selection (Default: 0b) 0: Left Channel 1: Right Channel

### 8.53. Index-21h: Auto Volume Control Register 1

Default: 2710h

**Table 67. Index-21h: Auto Volume Control Register 1**

Bit	Type	Function
15	-	Reserved
14:0	RW	The Maximum internal PCM data absolute level after AVC, Thmax (=0 ~ 2 <sup>15</sup> -1)

### 8.54. Index-22h: Auto Volume Control Register 2

Default: 0BB8h

**Table 68. Index-22h: Auto Volume Control Register 2**

Bit	Type	Function
15	-	Reserved
14:0	RW	The Minimum internal PCM data absolute level after AVC, Thmin (=0 ~ 2 <sup>15</sup> -1)

### 8.55. Index-23h: Auto Volume Control Register 3

Default: 01F4h

**Table 69. Index-23h: Auto Volume Control Register 3**

Bit	Type	Function
15	-	Reserved
14:0	RW	The Non-active internal PCM data absolute level AVC will keep analog unit gain, Thnonact (=0 ~ 2 <sup>15</sup> -1)

*Note: Initial Index23=0001'h.*

### 8.56. Index-24h: Auto Volume Control Register 4

Default: 0190h

**Table 70. Index-24h: Auto Volume Control Register 4**

Bit	Type	Function
15:0	RW	The CNTMAXTH1 to control the sensitivity to increase Gain (Unit:2 <sup>1</sup> ) This value should be less than CNTMAXTH2 (Max:2 <sup>17</sup> )

## 8.57. Index-25h: Auto Volume Control Register 5

Default: 0200h

**Table 71. Index-25h: Auto Volume Control Register 5**

Bit	Type	Function
15:0	RW	The CNTMAXTH2 to control the sensitivity to decrease Gain (Unit:2 <sup>1</sup> ) This value should be less than Monitor Window (Optimized: 1/2 Monitor Window) (Max:2 <sup>17</sup> )

Note: CNTMAXTH1 < CNTMAXTH2.

## 8.58. Index-39h: Digital Internal Register

Default: 9000h

**Table 72. Index-39h: Digital Internal Register**

Bit	Type	Function
15	RW	Pad Drive Capability 0b: Weak drive 1b: Strong drive
14:0	RW	Reserved

## 8.59. Index-4Ah: Class-D Temperature Sensor

Default: 4444h

**Table 73. Index-4Ah: Class-D Temperature Sensor**

Bit	Type	Function
15	RW	Reserved
14:12	RW	RP Channel Temp. Sensor Threshold Setting 001: 35°C      011: 65°C      101: 95°C      111: 125°C
11	RW	Reserved
10:8	RW	RN Channel Temp. Sensor Threshold Setting 001: 35°C      011: 65°C      101: 95°C      111: 125°C
7	RW	Reserved
6:4	RW	LP Channel Temp. Sensor Threshold Setting 001: 35°C      011: 65°C      101: 95°C      111: 125°C
3	RW	Reserved
2:0	RW	LN Channel Temp. Sensor Threshold Setting 001: 35°C      011: 65°C      101: 95°C      111: 125°C

Note: Tolerance: ± 15°C.

## 8.60. Index-54h: AD\_DA\_Mixer\_Internal Register

Default: E184h

**Table 74. Index-54h: AD\_DA\_Mixer\_Internal Register**

Bit	Type	Function
15	RW	Reserved
14:13	RW	DAC Reference Source 01: Internal DAC reference (AVDD1 & DAC reference cannot be bonded together) 11: External DAC reference (AVDD/AGND as DAC reference) Others: Forbidden
12:3	RW	Reserved
2:0	RW	Temp. Sensor for Threshold Setting 001: 35°C                                      011: 65°C 101: 95°C                                      111: 125°C <i>Note: Tolerance: ± 15°C.</i>

*Note: To reduce DAC power consumption, we suggest that Index54=E184'h be initialized.*

## 8.61. Reg-74h: Touch Panel Control Byte 1

Default: 008Ch

**Table 75. Reg-74h: Touch Panel Control Byte 1**

Name	Bits	Read/Write	Reset State	Description
pow_tp_ctrl	15:14	RW	0'h	Touch Panel Power Control 00: All OFF 01: AUX_ADC is OFF, pen-down is ON, and AUX_ADC will be turned ON once pen-down is detected. 10: AUX_ADC is OFF, pen-down is ON, but AUX_ADC will not be turned ON even if pen-down is detected. 11: AUX_ADC ON
pressure_source_current	13:10	RW	0'h	Pressure Measurement Source Current 0000b: OFF 0001b: 25µA 0010b: 50µA ..... 1111b: 375µA
Reserved	9	RW	0'h	Reserved
tp_adc_delay_sel	8:7	RW	1'h	Touch Panel ADC Measure Delay After Switch Matrix Setting Change (1 Frame =20.8us) 00: 4 frame                                      01: 8 frame (Default) 10: 16 frame                                      11: 32 frame
slot_readback_En	6	RW	0'b	Slot Readback Enable (Control for continuous and polling mode) 0b: Disable                                      1b: Enable



### 8.63. Reg-78h: Touch Panel Indication

Default: 0000h

**Table 77. Reg-78h: Touch Panel Indication**

Name	Bits	Read/Write	Reset State	Description
pen_status	15	R	0'h	Indicates Pen Status after AUX_ADC Measured 0: Pen-up 1: Pen-down
pipe_adc_source	14:12	R	0'h	AUX ADC Source 000: No Data (AUX_ADC Busy) 001: X co-ordinate measurement 010: Y co-ordinate measurement 011: Pressure measurement 100: Reserved 101: Reserved 110: Reserved 111: AUX
pipe_adc_rpt	11:0	R	0'h	AUX ADC Data Report

### 8.64. Reg-7Ch: VENDOR ID 1

Default: 10ECh

**Table 78. Reg-7Ch: VENDOR ID 1**

Name	Bits	Read/Write	Reset State	Description
vender_id1	15:0	R	10EC'h	Vendor ID=10EC

### 8.65. Reg-7Eh: VENDOR ID 2

Default: 1003h

**Table 79. Reg-7Eh: VENDOR ID 2**

Name	Bits	Read/Write	Reset State	Description
vender_id	15:8	R	10'h	Device ID=10
device_id2	7:0	R	03'h	Version ID=03

## 9. Electrical Characteristics

### 9.1. DC Characteristics

#### 9.1.1. Absolute Maximum Ratings

**Table 80. Absolute Maximum Ratings**

Parameter	Symbol	Min	Typ	Max	Units
Power Supplies					
Digital IO Buffer	DVDD1	-0.3	-	3.63	V
Digital Core	DVDD2	-0.3	-	3.63	V
Analog	AVDD	-0.3	-	3.63	V
Touch Panel	TPVDD	-0.3	-	3.63	V
Headphone	HPVDD	-0.3	-	3.63	V
Speaker	SPKVDD	-0.3	-	7 <sup>1</sup>	V
Operating Ambient Temperature	T <sub>a</sub>	-25	-	+85	°C
Storage Temperature	T <sub>s</sub>	-55	-	+125	°C

Note 1: SPKVDD=5V with 3.5% duty cycle Power bouncing up to SPKVDD=8V is acceptable.

#### 9.1.2. Recommended Operating Conditions

**Table 81. Recommended Operating Conditions**

Parameter	Symbol	Min	Typ	Max	Units
Digital IO Buffer	DVDD1	1.8	3.3	3.6	V
Digital Core	DVDD2	1.8	3.3	3.6	V
Analog	AVDD	2.3	3.3	3.6	V
Touch Panel	TPVDD	2.3	3.3	3.6	V
Headphone	HPVDD	2.3	3.3	3.6	V
Speaker	SPKVDD <sup>1</sup>	2.3	3.3	5	V

Note 1: A 10 $\mu$ F Capacitor must be connected from SPKVDD to SPKGND, and should be placed as close as possible to the SPKVDD pin of the ALC5611.

#### 9.1.3. Static Characteristics

**Table 82. Static Characteristics**

Parameter	Symbol	Min	Typ	Max	Units
Input Voltage Range	V <sub>IN</sub>	-0.30	-	DVDD+0.30	V
Low Level Input Voltage	V <sub>IL</sub>	-	-	0.35DVDD	V
High Level Input Voltage	V <sub>IH</sub>	0.65DVDD	-	-	V
High Level Output Voltage	V <sub>OH</sub>	0.9DVDD	-	-	V
Low Level Output Voltage	V <sub>OL</sub>	-	-	0.1DVDD	V
Input Leakage Current	-	-1	-	1	$\mu$ A
Output Leakage Current (Hi-Z)	-	-1	-	1	$\mu$ A
Output Buffer High Drive Current	-	-	22	-	mA
Output Buffer Low Drive Current	-	-	10	-	mA
V <sub>MID</sub> Internal Serial Resistor	-	25	50	75	K $\Omega$
V <sub>MID</sub> Internal Serial Resistor Ratio	-	95	100	105	%

Note: DVDD=3.3V, T<sub>ambient</sub>=25°C, with 50pF external load.



## 9.2. Analog Performance Characteristics

**Table 83. Analog Performance Characteristics**

Parameter	Min	Typ	Max	Units
Full Scale Input Voltage				
Line Inputs	-	1.0	-	Vrms
MIC Inputs (Non-Boost)	-	1.0	-	Vrms
MIC Inputs (Boost 20dB)	-	0.1	-	Vrms
ADC	-	0.7	-	Vrms
Full Scale Output Voltage				
MONO Outputs	-	1.0	-	Vrms
Headphone Amplifiers Outputs	-	1.0	-	Vrms
Speaker Amplifiers Outputs	-	1.3	-	Vrms
S/N Ratio (A-weighted, HPL/R or MONO with 10K $\Omega$ /50pF Load)				
STEREO DAC	-	90	-	dB
STEREO ADC	-	85	-	dB
Total Harmonic Distortion + Noise (HPL/R or MONO with 10K $\Omega$ /50pF Load)				
STEREO DAC	-	-85	-	dB
STEREO ADC	-	-80	-	dB
MIC Boost Amplifier				
Gain=20dB	18	20	22	dB
Gain=30dB	-	30	-	dB
Gain=40dB	-	40	-	dB
Input Impedance (Gain=0dB, ADC Mixer=On/Off)				
PHONEN (Differential Mode)	-	16	-	K $\Omega$
MIC1N, MIC2N (Differential Mode)	-	16	-	K $\Omega$
MIC1P, MIC2P	-	16	-	K $\Omega$
PHONEP	-	16	-	K $\Omega$
Input Impedance (Gain=0dB, ADC Mixer=On)				
LINE_IN	12.8	16	19.2	K $\Omega$
Input Impedance (Gain=0dB, ADC Mixer=Off)				
LINE_IN	25.6	32	38.4	K $\Omega$
Output Impedance				
MONO_OUT	-	2	-	$\Omega$
HP_OUT	-	2	-	$\Omega$
SPK_OUT (Class-AB)	-	1	-	$\Omega$
SPK_OUT (Class-D)	-	0.3	0.4	$\Omega$
MONO_OUT Amplifier Output Power (32 $\Omega$ Load)				
Single-Ended Mode	25	-	-	mW
BTL Mode	75	-	-	mW
MONO_OUT Amplifier Quiescent Current (32 $\Omega$ load)/CH	-	700	-	$\mu$ A
MONO_OUT Amplifier Efficiency ( $f_N=1$ kHz, 32 $\Omega$ Load)				
Single-Ended Mode (Output Power=25mW)	50	-	-	%
BTL Mode (Output Power=75mW)	50	-	-	%

Parameter	Min	Typ	Max	Units
MONO_OUT Amplifier THD+N Single-Ended Mode (10K $\Omega$ Load) Output Power=0.1mW	-	0.01	-	%
BTL Mode (10K $\Omega$ Load) Output Power=0.1mW	-	0.01	-	%
MONO_OUT Amplifier PSRR	-	60	-	dB
Headphone Amplifier Output Power (32 $\Omega$ Load)	-	-	31.25	mW
Headphone Amplifier Quiescent Current (32 $\Omega$ Load)	-	700	-	$\mu$ A
Headphone Amplifier Efficiency ( $f_{IN}$ =1kHz, 32 $\Omega$ Load, Output Power=25mW)	50	-	-	%
Headphone Amplifier THD+N (32 $\Omega$ Load) Output Power=20mW	-	-70	-	dB
Output Power=25mW	-	-70	-	dB
Headphone Amplifier PSRR	-	68	-	dB
Class-D BTL Speaker Amplifier Output Power (SPKVDD=5V with 8 $\Omega$ Load, 1% THD+N)	-	1	-	W
(SPKVDD=5V with 8 $\Omega$ Load, 10% THD+N)	-	1.2	-	W
(SPKVDD=5V with 4 $\Omega$ Load, 1% THD+N)	-	1.4	-	W
(SPKVDD=5V with 4 $\Omega$ Load, 10% THD+N)	-	1.7	-	W
Class-D BTL Speaker Amplifier Output Power (SPKVDD=4.2V with 8 $\Omega$ Load, 1% THD+N)	-	0.7	-	W
(SPKVDD=4.2V with 8 $\Omega$ Load, 10% THD+N)	-	0.9	-	W
(SPKVDD=4.2V with 4 $\Omega$ Load, 1% THD+N)	-	1	-	W
(SPKVDD=4.2V with 4 $\Omega$ Load, 10% THD+N)	-	1.2	-	W
BTL Speaker Amplifier Quiescent Current (8 $\Omega$ Load, SPKVDD=3.7V)				
Class-AB_Strong	-	7	-	mA
Class-D	-	4	-	mA
BTL Speaker Amplifier Efficiency ( $f_{IN}$ =1kHz, 8 $\Omega$ Load, Output Power=700mW)				
Class-AB	50	-	-	%
Class-D	-	82	-	%
BTL Speaker Amplifier THD+N (8 $\Omega$ Load, SPKVDD=5V)				
Class-AB_Strong				
Output Power=350mW	-	-70	-	dB
Output Power=600mW	-	-70	-	dB
Class-D				
Output Power=350mW	-	-70	-	dB
Output Power=600mW	-	-60	-	dB
BTL Speaker Amplifier THD+N Class-AB_Weak (10K $\Omega$ /50pF Load)	-	-85	-	dB
BTL Speaker Amplifier SNR (A-Weighted) Class-AB_Weak (10K $\Omega$ /50pF Load)	-	90	-	dB
BTL Speaker Amplifier PSRR	-	65	-	dB

Parameter	Min	Typ	Max	Units
Quiescent Playback Current (DAC to HP_OUT with 16Ω Load)	-	7.4	-	mA
Quiescent Record Current (LINE_IN to ADC)	-	11.3	-	mA
Power Down Current				
I <sub>DDA</sub> (Analog Block)	-	-	10	μA
I <sub>DDD</sub> (Digital Block)	-	-	1	μA
MICBIAS1 Output Voltage				
0.75*AVDD Setting	-	2.475	-	V
0.9*AVDD Setting	-	2.97	-	V
MICBIAS1 and MICBIAS2 Drive Current	-	16	-	mA
MICBIAS2 Output Voltage				
0.75*AVDD Setting	-	2.475	-	V
0.9*AVDD Setting	-	2.97	-	V
Verf Pull Up Resistor	-	50	-	KΩ

Note: Standard test conditions:

$T_{ambient} = 25\text{ }^{\circ}\text{C}$ ,  $DVDD = AVDD = HPVDD = 3.3\text{V}$ ,  $SPKVDD = 4.2\text{V}$ .

1kHz input sine wave; internal PCM data Sampling frequency=48kHz; 0dB=1Vrms, Test bench Characterization BW: 10Hz~22kHz, 0dB attenuation; EQ and 3D disabled.

### 9.3. Signal Timing

#### 9.3.1. Cold Reset

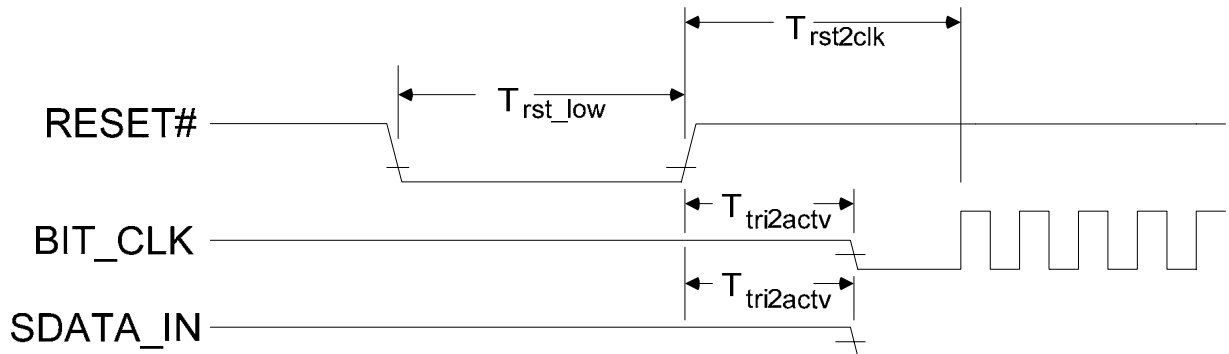


Figure 14. Cold Reset Timing

Table 84. Cold Reset Timing Parameters

Parameter	Symbol	Min	Typ	Max	Units
RESET# Active Low Pulse Width	$T_{rst\_low}$	1.0	-	-	$\mu$ s
RESET# Inactive to SDATA-IN or BITCLK Active Delay	$T_{tri2actv}$	-	-	25	ns
RESET# Inactive to BIT_CLK Startup Delay	$T_{rst2clk}$	162.8	-	-	ns

#### 9.3.2. Warm Reset

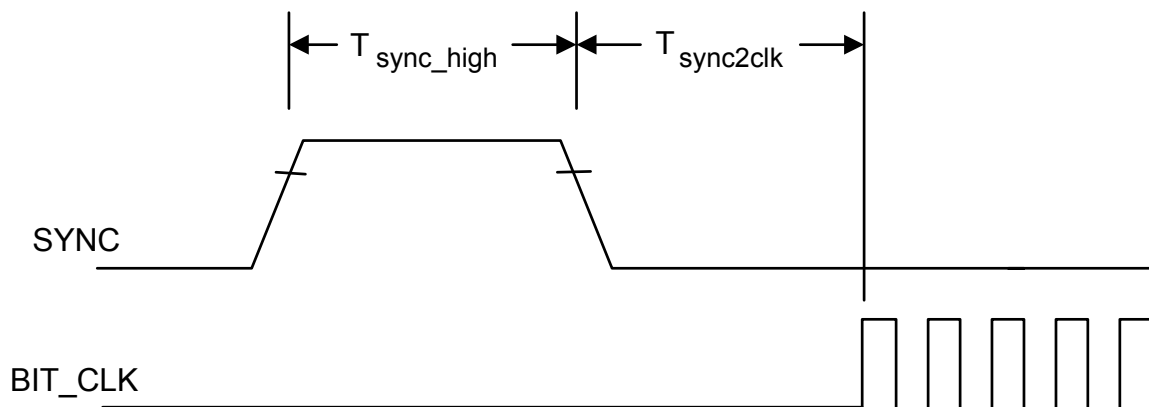


Figure 15. Warm Reset Timing

Table 85. Warm Reset Timing Parameters

Parameter	Symbol	Min	Typ (Design)	Max	Units
SYNC Active High Pulse Width	$T_{sync\_high}$	1.0	1.3 (16 BCLK)	-	$\mu$ s
SYNC Inactive to BIT_CLK Startup Delay	$T_{sync2clk}$	0.1628	-	400	$\mu$ s

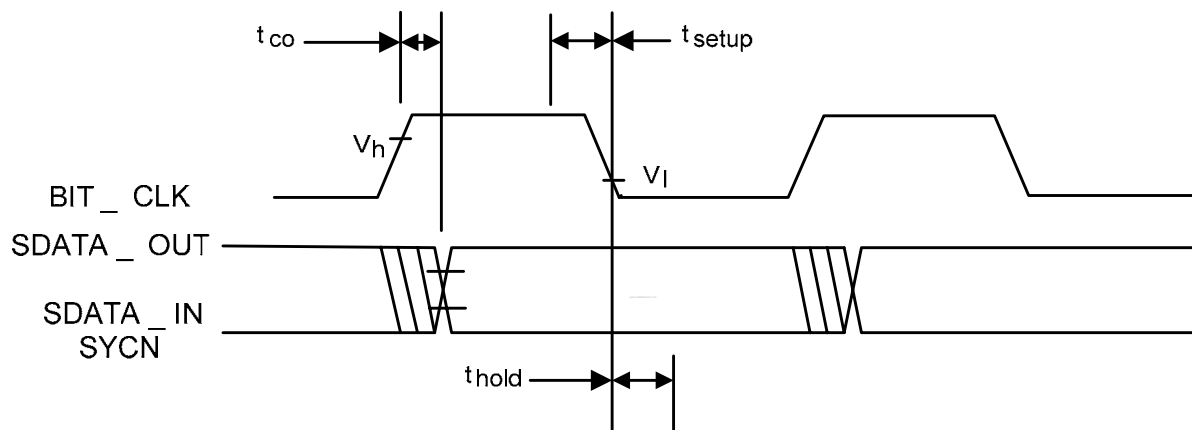
### 9.3.3. AC-Link Clocks

**Table 86. AC-Link Clock Parameters**

Parameter	Symbol	Min	Typ	Max	Units
BIT_CLK Frequency	-	-	12.288	-	MHz
BIT_CLK Period	$T_{clk\_period}$	-	81.4	-	ns
BIT_CLK Output Jitter	-	-	-	750	ps
BIT_CLK High Pulse Width*	$T_{clk\_high}$	36	40.7	45	ns
BIT_CLK Low Pulse Width*	$T_{clk\_low}$	36	40.7	45	ns
SYNC Frequency	-	-	48.0	-	kHz
SYNC Period	$T_{sync\_period}$	-	20.8	-	$\mu$ s
SYNC High Pulse Width	$T_{sync\_high}$	-	1.3	-	$\mu$ s
SYNC Low Pulse Width	$T_{sync\_low}$	-	19.5	-	$\mu$ s

Note: Worse case duty cycle restricted to 45/55.

### 9.3.4. AC-Link Data Output and Input Timing


**Figure 16. Data Output and Input Timing**
**Table 87. AC-Link Data Timing Parameters**

Parameter	Symbol	Min	Typ	Max	Units
Output Valid Delay from Rising Edge of BIT_CLK	$t_{co}$	-	-	15	ns

Note 1: Timing is for SDATA and SYNC outputs with respect to BIT\_CLK at the device driving the output.

Note 2: 50pF external load.

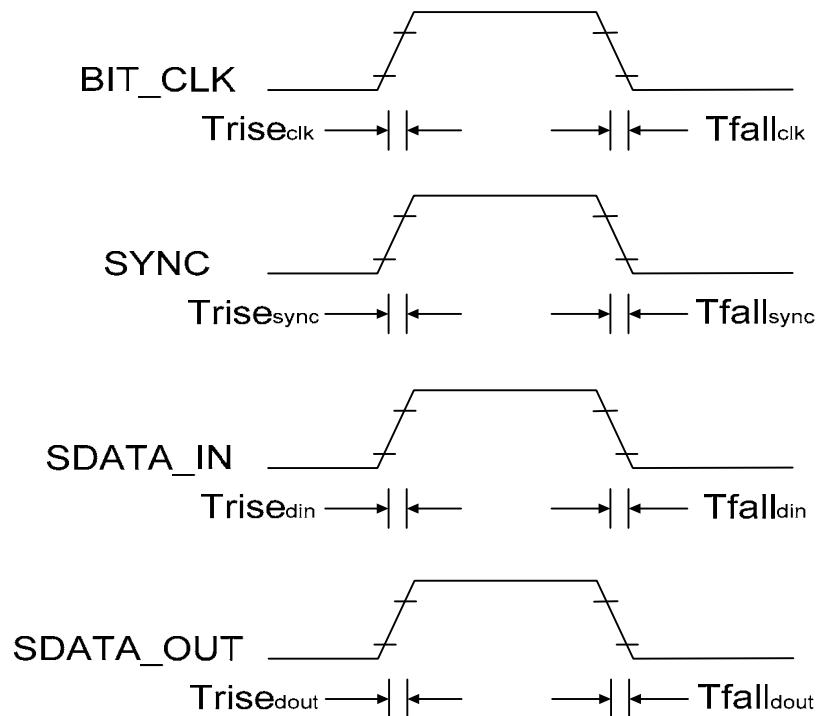
Parameter	Symbol	Min	Typ	Max	Units
Input Setup to Falling Edge of BIT_CLK	$t_{setup}$	10	-	-	ns
Input Hold from Falling Edge of BIT_CLK	$t_{hold}$	10	-	-	ns

Note: Timing is for SDATA and SYNC outputs with respect to BIT\_CLK at the device driving the output.

Parameter	Symbol	Min	Typ	Max	Units
BIT_CLK Combined Rise or Fall Plus Flight Time	-	-	-	7	ns
SDATA Combined Rise or Fall Plus Flight Time	-	-	-	7	ns

Note: Combined rise or fall plus flight times are provided for worst case scenario modeling purposes.

### 9.3.5. AC-Link Signal Rise and Fall Timing



**Figure 17. Signal Rise and Fall Timing**

**Table 88. AC-Link Signal Rise and Fall Timing Parameters**

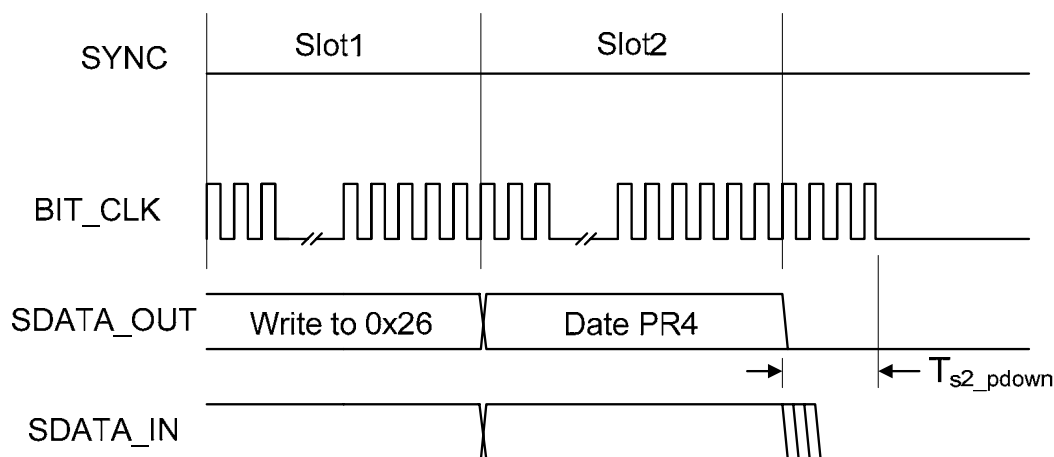
Parameter	Symbol	Min	Typ	Max	Units
BIT_CLK Rise Time	$T_{rise_{clk}}$	-	-	6	ns
BIT_CLK Fall Time	$T_{fall_{clk}}$	-	-	6	ns
SYNC Rise Time	$T_{rise_{sync}}$	-	-	6	ns
SYNC Fall Time	$T_{fall_{sync}}$	-	-	6	ns
SDATA_IN Rise Time	$T_{rise_{din}}$	-	-	6	ns
SDATA_IN Fall Time	$T_{fall_{din}}$	-	-	6	ns
SDATA_OUT Rise Time	$T_{rise_{dout}}$	-	-	6	ns
SDATA_OUT Fall Time	$T_{fall_{dout}}$	-	-	6	ns

Note 1: 55pF external load (50pF in AC'97 rev2.1), only for PC system verify case.

Note 2: Rise is from 10% to 90% of  $V_{dd}$  ( $V_{ol}$  to  $V_{oh}$ ).

Note 3: Fall is from 90% to 10% of  $V_{dd}$  ( $V_{oh}$  to  $V_{ol}$ ).

### 9.3.6. AC-Link Low Power Mode Timing



**Figure 18. AC-Link Low Power Mode Timing**

**Table 89. AC-Link Low Power Mode Timing Parameters**

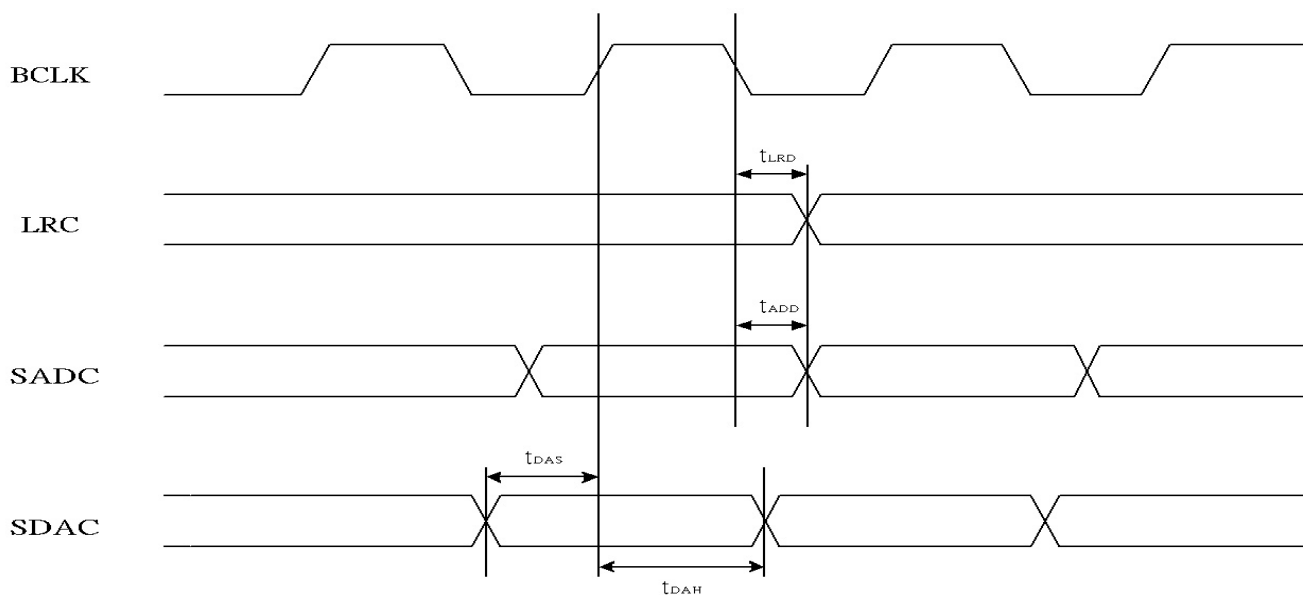
Parameter	Symbol	Min	Typ	Max	Units
End of Slot 2 to BIT_CLK, SDATA_IN Low	$T_{s2\_pdown}$	-	-	1.0	$\mu s$

### 9.3.7. AC-Link IO Pin Capacitance and Loading

**Table 90. AC-Link IO Pin Capacitance Parameters**

Output Pin	For PC	For PDA	Units
RESET#, SYNC & SDATA_OUT	47.5	25	pF
BIT_CLK	47.5	25	pF
SDATA_IN	47.5	25	pF

### 9.3.8. I<sup>2</sup>S/PCM Interface Master Mode



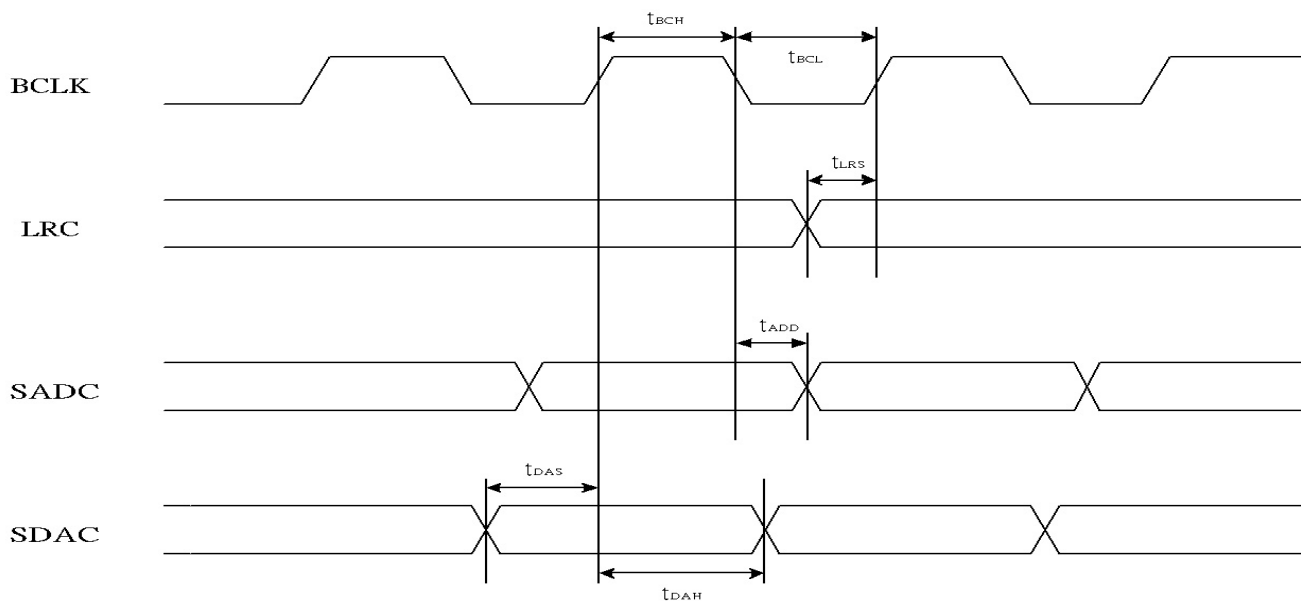
**Figure 19. Timing of I<sup>2</sup>S/PCM Master Mode**

**Table 91. Timing of I<sup>2</sup>S/PCM Master Mode**

Parameter	Symbol	Min	Typ	Max	Units
LRCK Output to BCLK Delay	$t_{LRD}$	-	-	30	ns
Data Output to BCLK Delay	$t_{ADD}$	-	-	30	ns
Data Input Setup Time	$t_{DAS}$	10	-	-	ns
Data Input Hold Time	$t_{DAH}$	10	-	-	ns



### 9.3.9. I<sup>2</sup>S/PCM Interface Slave Mode

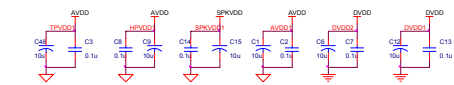


**Figure 20. I<sup>2</sup>S/PCM Slave Mode Timing**

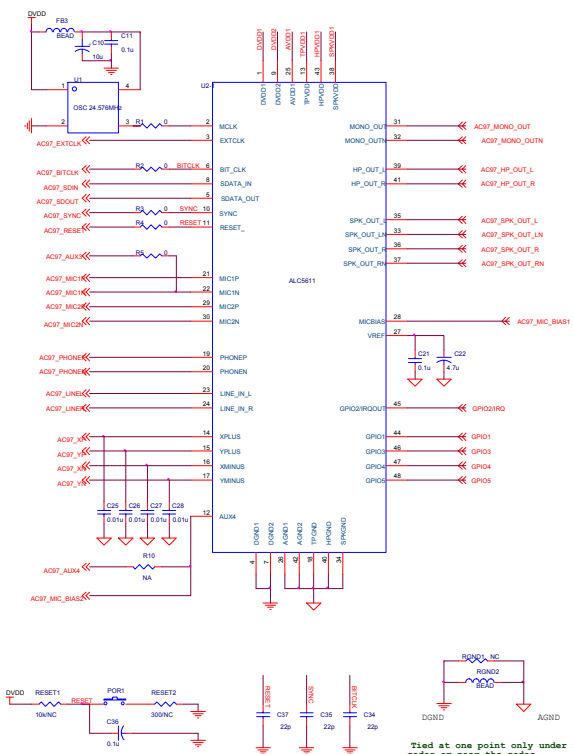
**Table 92. I<sup>2</sup>S/PCM Slave Mode Timing**

Parameter	Symbol	Min	Typ	Max	Units
BCLK High Pulse Width	$t_{BCH}$	20	-	-	ns
BCLK Low Pulse Width	$t_{BCL}$	20	-	-	ns
LRCK Input Setup Time	$t_{LRS}$	30	-	-	ns
Data Output to BCLK Delay	$t_{ADD}$	-	-	30	ns
Data Input Setup Time	$t_{DAS}$	10	-	-	ns
Data Input Hold Time	$t_{DAH}$	10	-	-	ns

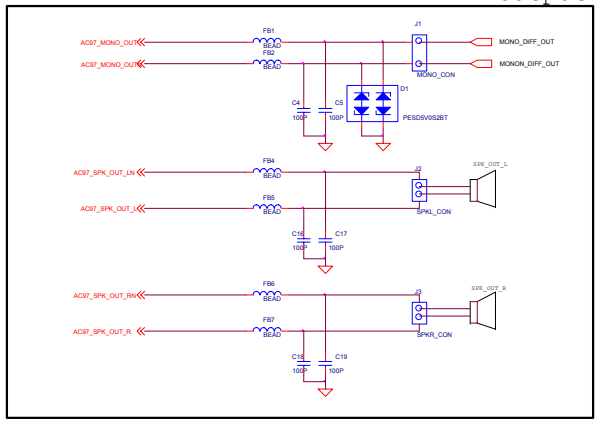
# 10. Application Circuits



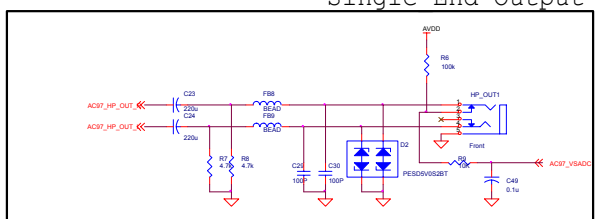
\*NOTE: For SPK\_VDD by pass cap, C15= 10u is necessary



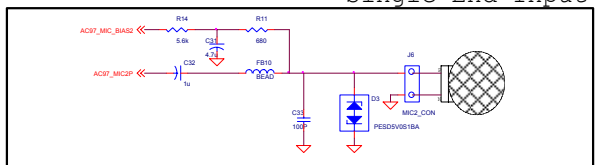
BTL Output



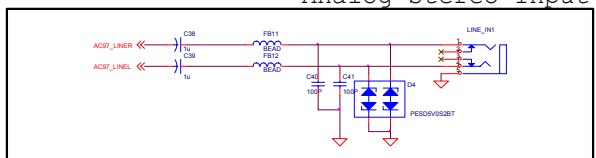
Single End Output



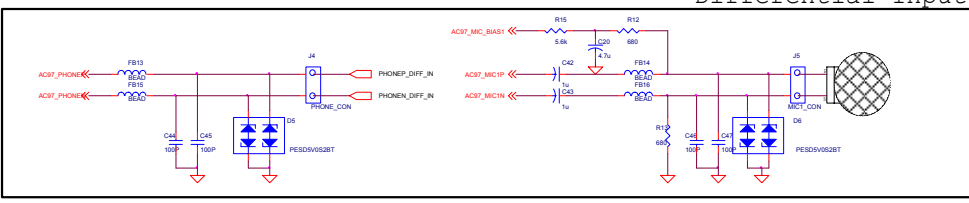
Single End Input



Analog Stereo Input

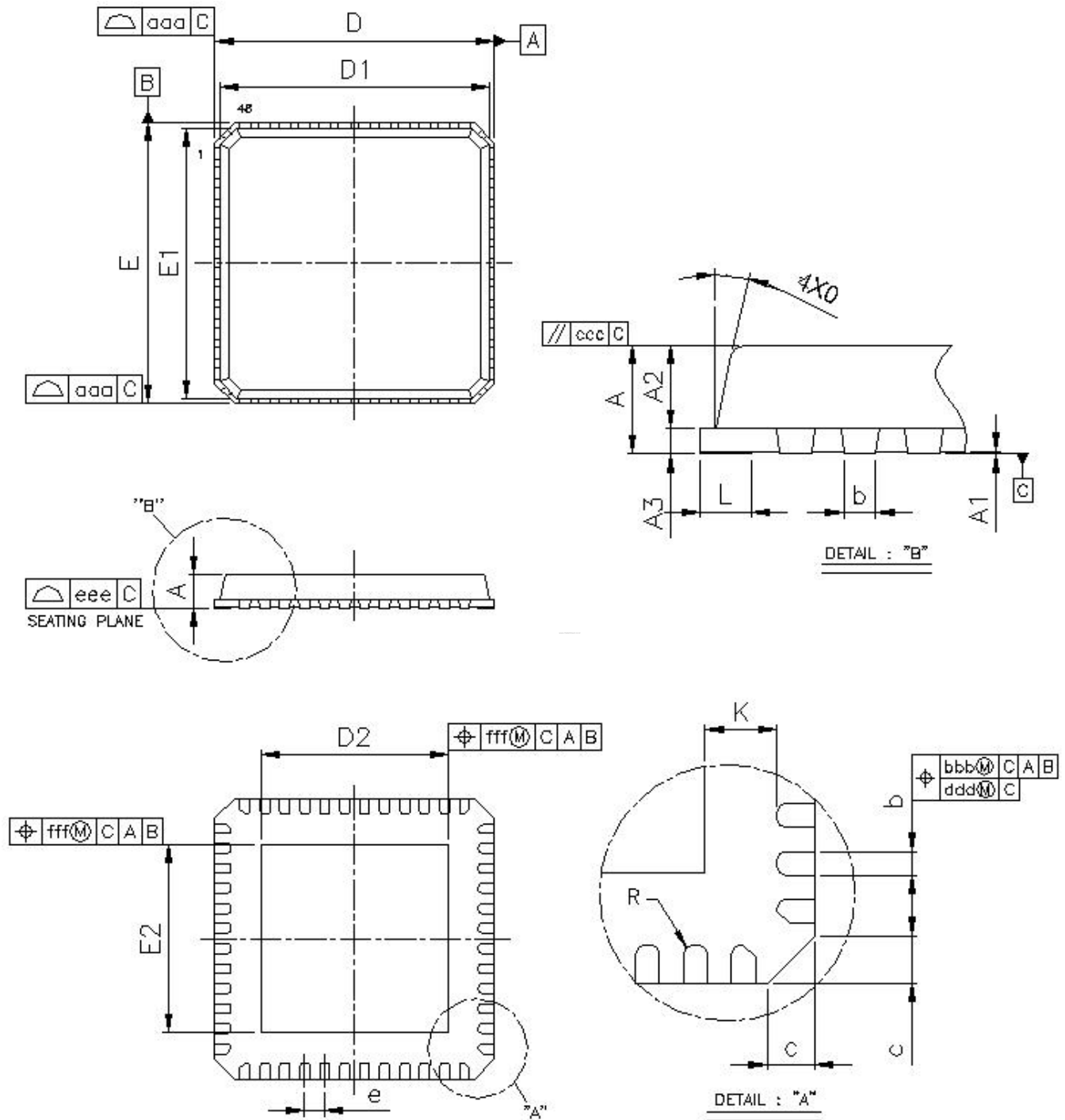


Differential Input



# 11. Mechanical Dimensions

## Plastic Quad Flat No-Lead Package 48 Leads 7x7mm Outline



Symbol	Dimension in mm			Dimension in inch		
	Min	Nom	Max	Min	Nom	Max
A	0.75	0.85	1.00	0.030	0.034	0.039
A <sub>1</sub>	0.00	0.02	0.05	0.000	0.001	0.002
A <sub>2</sub>	0.55	0.65	0.80	0.022	0.026	0.032
A <sub>3</sub>	0.20REF			0.008REF		
b	0.18	0.25	0.30	0.007	0.010	0.012
c	-	-	0.6	-	-	0.024
D/E	7.00BSC			0.276BSC		
D <sub>1</sub> /E <sub>1</sub>	6.75BSC			0.266BSC		
D <sub>2</sub> /E <sub>2</sub>	4.80	5.05	5.30	0.189	0.199	0.209
e	0.50BSC			0.020BSC		
L	0.30	0.40	0.50	0.012	0.016	0.020
K	0.2	-	-	0.008	-	-
θ	0°	-	14°	0°	-	14°
aaa	-	-	0.15	-	-	0.006
bbb	-	-	0.10	-	-	0.004
ccc	-	-	0.10	-	-	0.004
ddd	-	-	0.05	-	-	0.002
eee	-	-	0.08	-	-	0.003
fff	-	-	0.10	-	-	0.004

Note 1: CONTROLLING DIMENSION: MILLIMETER (mm).

Note 2: REFERENCE DOCUMENT: JEDEC MO-220.

## 12. Ordering Information

**Table 93. Ordering Information**

<b>Part Number</b>	<b>Package</b>	<b>Status</b>
ALC5611-GR	QFN-48 in 'Green' Package (Tray)	MP
ALC5611-GRT	QFN-48 in 'Green' Package (Tape & Reel)	MP

*Note 1: See page 6 for Green package and version identification.*

*Note 2: Above parts are tested under AVDD=3.3V.*

---

**Realtek Semiconductor Corp.****Headquarters**

No. 2, Innovation Road II

Hsinchu Science Park, Hsinchu 300, Taiwan

Tel.: +886-3-578-0211. Fax: +886-3-577-6047

[www.realtek.com](http://www.realtek.com)