

FEATURES

- Synchronization
- 6 sided Continuous Shielding
- 9.38W/In³ Power Density
- Efficiency to 82%
- VDE / EN 60950 Approved
- >1,000,000 Hours MTBF

DESCRIPTIONS

The 800 series is family of miniature, high performance and high reliability DC/DC converters. The 800 series operates over 2:1 input voltage ranges of 9 to 18, 18 to 36 or 36 to 72VDC; providing single, dual and triple output combinations of 5, 12, 15, ± 5 , ± 12 , ± 15 , $5/\pm 12$ and $5/\pm 15$ VDC. Standard features include 500VDC input/output isolation, efficiency as high as 82%, tight line/load regulation and low output ripple and noise. All 24 models are packaged in compact, low profile 1" X 2" X 0.4" metal cases.

OUTPUT CHARACTERISTICS

	Min	Typ	Max	Unit/Comments
Output Voltage Accuracy				
Single & Dual Outputs			± 1.0	% ¹
Triple Outputs - Primary			± 1.0	% ¹
- Auxiliaries			± 6.0	% ¹
Voltage Balance:				
Dual Outputs			± 1.0	%; Equal Output Loads
Triple Outputs (Auxiliaries)			± 1.0	%; Equal Output Loads
Minimum Load	10%			Full Load
Line Regulation				
Single & Dual Outputs			± 0.5	% ²
Triple Outputs - Primary			± 0.5	% ²
- Auxiliaries			5.0	% ²
Load Regulation				
Single Outputs			± 0.5	% ³
Dual Outputs			± 1.0	% ³ ; Equal Loads
Triple Outputs - Primary			± 0.5	% ³
- Auxiliaries			± 6.0	% ³ ; Equal Loads
Ripple/Noise			2	% of Vout (20 MHz B.W.)
Short Circuit Protection				Continuous, Auto- matic Recovery
Transient Recovery Time		200		μ S to within 1% error band for 50% step load change
Temperature Coefficient			± 0.01	% per °C
Over Voltage Protection				See Model Selection Guide

INPUT CHARACTERISTICS

	Min	Typ	Max	Unit/Comments
Input Voltage Range				
12 VDC Input Models	9	12	18	VDC
24 VDC Input Models	18	24	36	VDC
48 VDC Input Models	36	48	72	VDC
Remote On / OFF Control				
Supply ON				0 VDC to 0.6 VDC
Supply OFF				1 VDC to 5 VDC
Logic Referenced to Negative Input				
Input Filter				LC Type
Input Fuse Rating				See Model Selection Guide

GENERAL CHARACTERISTICS

	Min	Typ	Max	Unit/Comments
Switching Frequency	100			kHz
Isolation Voltage	500			VDC, 1 minute
Isolation Resistance	1000			Mohm, 500VDC
MTBF (MIL-HBK-217F)	1			Million Hours, +25°C, Ground Benign

¹ = Output voltage at nominal line & FL

² = % Output voltage measured from min. input line to maximum

³ = Output voltage measured from FL to 10% Load

ENVIRONMENTAL SPECIFICATIONS

	Min	Typ	Max	Unit/Comments
Operating Temp. Range	-30		+75	°C; Ambient
Storage Temp. Range	-40		+125	°C
Relative Humidity			95	% Humidity; non-condensing
Cooling				Free-Air Convection

PHYSICAL CHARACTERISTICS

	Unit/Comments
Case Size	1.0 X 2.0 X 0.4 inches (25.5 X 51.0 X 10.2 mm)
Case Material	Coated Metal
Shield Connection	
12V and 24V Input Models	Negative Input, Pin 3
48V Input Models	Positive Input, Pin 4
Flammability	UL94V-0
Weight	42.5 Grams

OUTLINE DRAWING

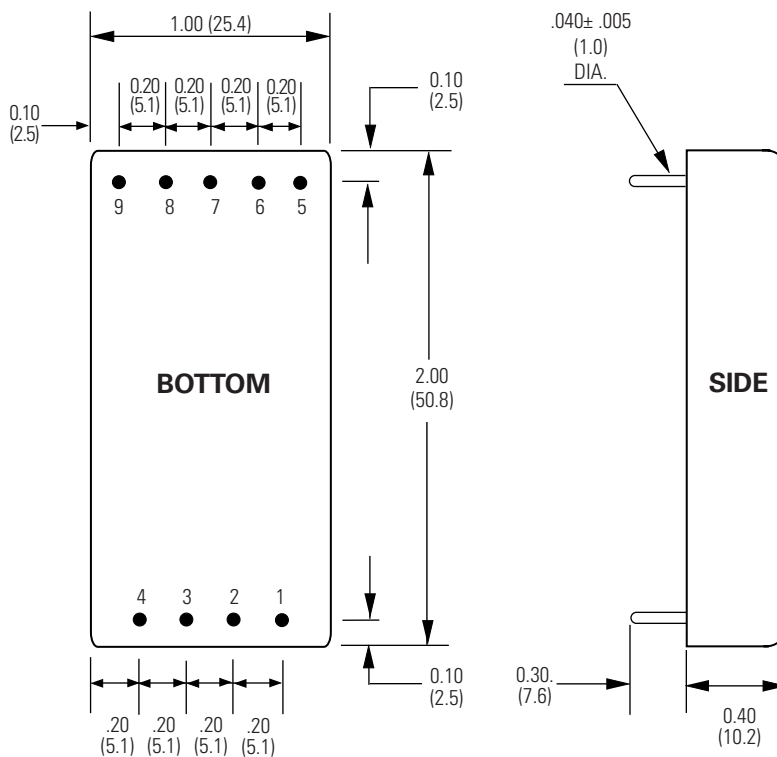

PIN OUT CHART

Pin	Single	Dual	Triple
1	Remote On/Off	Remote On/Off	Remote On/Off
2	Sync	Sync	Sync
3	- Vin	- Vin	- Vin
4	+ Vin	+ Vin	+ Vin
5	NC	- Vout	- Vout (Aux)
6	NC	Common	Common(Aux)
7	NC	+ Vout	+Vout (Aux)
8	- Vout	NC	+5V Common
9	+ Vout	NC	+5V Vout

NC = No Connection

Notes:

1. Unless otherwise specified dimensions are in inches (mm).

Tolerances	Inches	mm
	X.XX = ±0.02	X.X = ±0.5

All specifications are typical at nominal input, nominal load and 25° C unless otherwise specified. External, low ESR, 10 microfarad (minimum) capacitor across output is recommended for operation.

How To ORDER

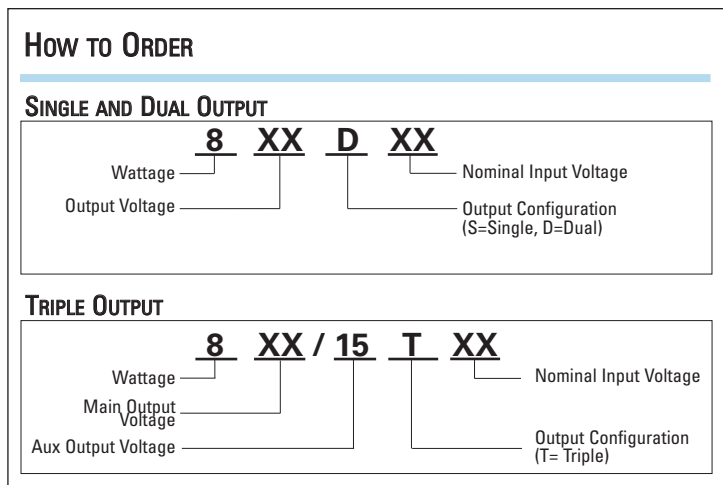

MODEL SELECTION CHART

Model	Nominal Input Voltage (VDC)	Output Voltage (VDC)	Full Load Output Current (mA)	No Load Input Current (mA)	Full Load Input Current (mA)	Input Reflected Ripple Current (mA)	Output Over Voltage (VDC)	Fuse (mA)	Efficiency @ FL (%)
805S12	12	5	1500	46	780	30	6.8	1500	79
812S12	12	12	625	46	786	30	15.0	1500	79
815S12	12	15	500	46	786	30	18.0	1500	79
805D12	12	±5	±750	46	786	30	±6.8	1500	79
812D12	12	±12	±300	46	786	30	±15.0	1500	80
815D12	12	±15	±250	46	786	30	±18.0	1500	80
805S24	24	5	1500	55	384	40	6.8	750	81
812S24	24	12	625	55	384	40	15.0	750	81
815S24	24	15	500	55	384	40	18.0	750	82
805D24	24	±5	±750	55	382	40	±6.8	750	82
812D24	24	±12	±300	55	382	40	±15.0	750	82
815D24	24	±15	±250	55	382	40	±18.0	750	82
805S48	48	5	1500	40	198	30	6.8	500	79
812S48	48	12	625	40	198	30	15.0	500	79
815S48	48	15	500	40	198	30	18.0	500	79
805D48	48	±5	±750	40	204	30	±6.8	500	78
812D48	48	±12	±300	40	198	30	±15.0	500	79
815D48	48	±15	±250	40	198	30	±18.0	500	79
805/12T12	12	5, ±12	1000±100	42	843	36	6.8, ±15.0	2000	79
805/15T12	12	5, ±15	1000±100	42	843	36	6.8, ±18.0	2000	79
805/12T24	24	5, ±12	1000±100	42	411	36	6.8, ±15.0	1000	81
805/15T24	24	5, ±15	1000±100	42	411	36	6.8, ±18.0	1000	81
805/12T48	48	5, ±12	1000±100	40	203	33	6.8, ±15.0	500	82
805/15T48	48	5, ±15	1000±100	40	203	33	6.8, ±18.0	500	82