

- Complies With ITU G.992.2 Standard
- 14-Bit Integrated A/D and D/A Converters
- 1.104 Msps Update Rate for the RX Channel
- 276 ksps Update Rate for the TX Channel
- Minimum 50 dB Missing Tone Rejection for DMT Signals
- Integrated TX/RX Filters
- Integrated Digital Phase Lock Loop (DPLL) and VCXO DAC
- Integrated Equalizer for Receive Channel
- Integrated PGA in Receive, and PAA in Transmit Channels
- Direct Single Serial Interface to TI's C54x or C6x DSP (Data and Control)
- Eight General-Purpose I/O Pins
- Software and Hardware Power-Down Modes
- Industrial Temperature Range (–40°C to 85°C)
- Integrated Auxiliary Amplifiers for System Flexibility
- Single 3.3 V Supply
- 80-Pin LQFP (PN) Package
- 2s Complement Data Format

description

The TLFD500PN is a high-speed analog front end for a remote terminal-side ADSL G.Lite modem. The device is designed to perform transmit encoding (D/A conversion), receive decoding (A/D conversion), transmit and receive filtering functions, and receive equalizer functions for a frequency division multiplex (FDM) G.Lite application. The receive channel has an update rate of 1.104 Msps, while the transmit channel has an update rate of 276 ksps. Both channels use 2s complement data format.

When used in a G.Lite system, the TLFD500PN requires a minimum number of external components. The device incorporates integrated filtering, DPLL, VCXO DAC (uses 2s complement data format), and 8 general-purpose I/O ports. The general-purpose I/O ports provide a means of reading or writing status bits in the system. Four auxiliary amplifiers on the chip can be configured (external components may be required) to provide additional onboard filtering and amplification.

A simple serial interface for data transfer on the digital side reduces system component count. The interface can be connected directly to the TI C6x and C54x families of DSPs.

The TLFD500PN device is available in an 80-pin PN LQFP package.



Please be aware that an important notice concerning availability, standard warranty, and use in critical applications of Texas Instruments semiconductor products and disclaimers thereto appears at the end of this data sheet.

PRODUCTION DATA information is current as of publication date. Products conform to specifications per the terms of Texas Instruments standard warranty. Production processing does not necessarily include testing of all parameters.



POST OFFICE BOX 655303 • DALLAS, TEXAS 75265

Copyright © 1999, Texas Instruments Incorporated

TLFD500PN

3.3 V INTEGRATED G.LITE ANALOG FRONT END

SLAS207A – JUNE 1999 – REVISED NOVEMBER 1999

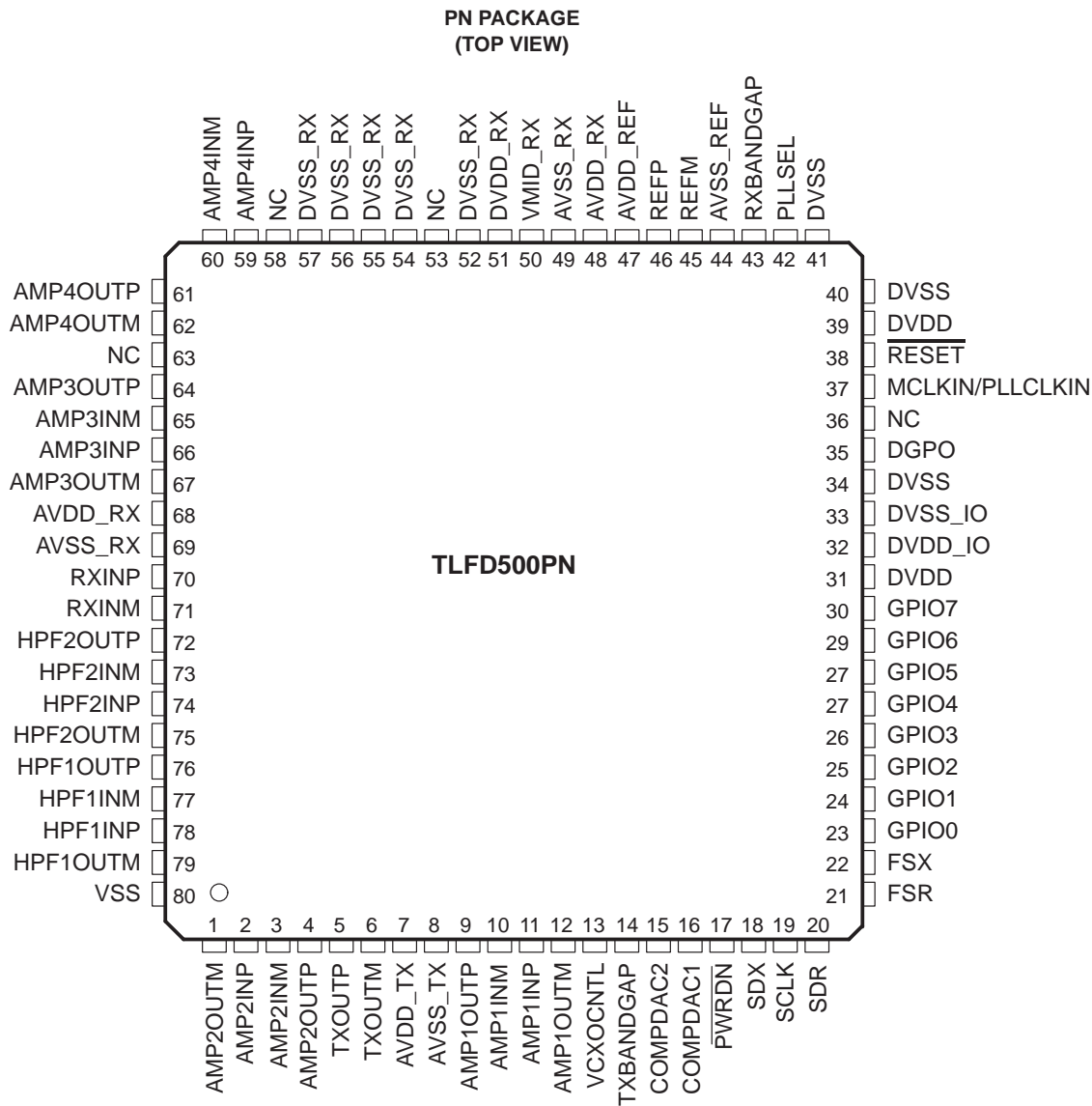

NC – No connection



POST OFFICE BOX 655303 • DALLAS, TEXAS 75265

TLFD500PN 3.3 V INTEGRATED G.LITE ANALOG FRONT END

SLAS207A – JUNE 1999 – REVISED NOVEMBER 1999

functional block diagram

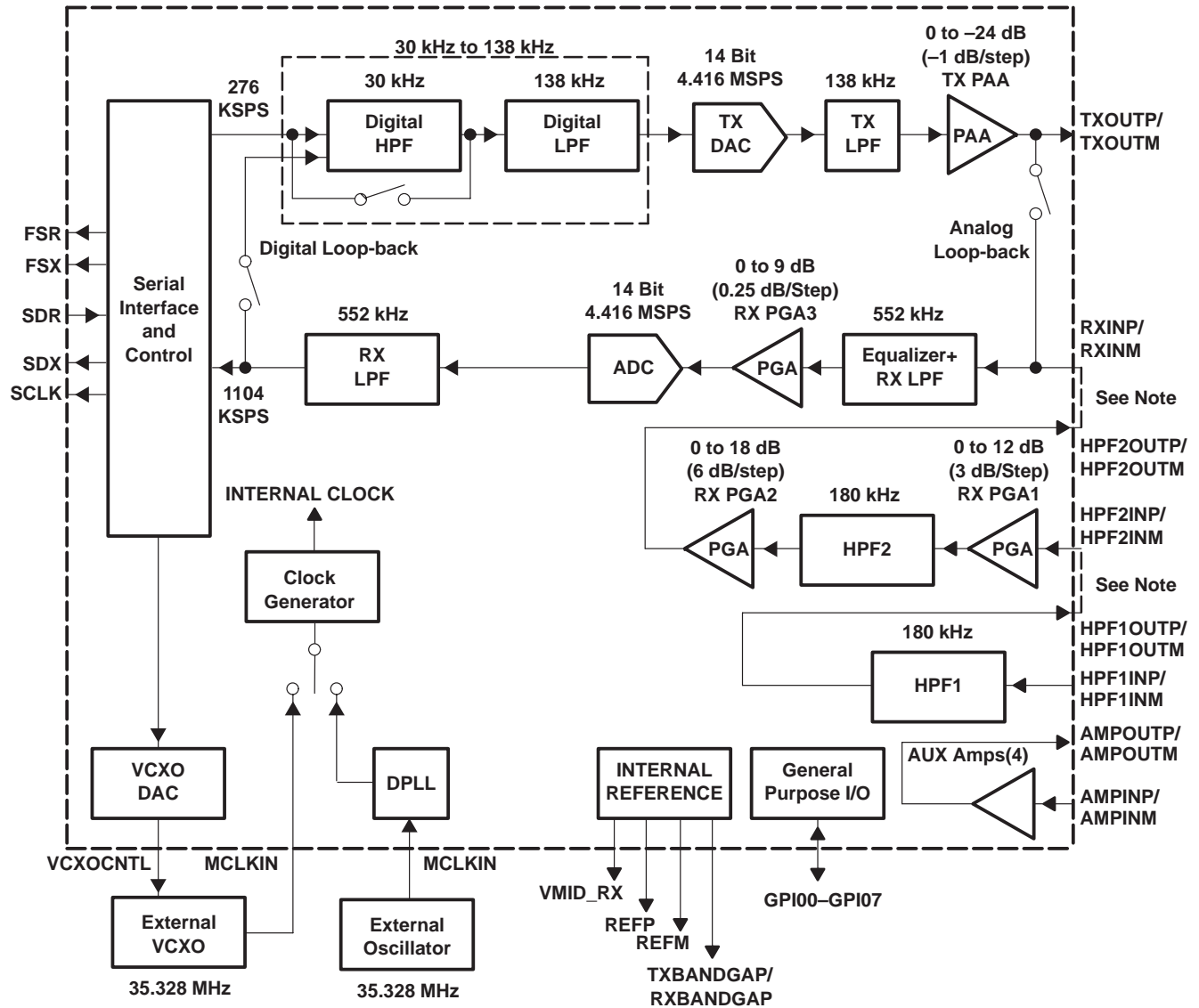

NOTE: Refer to Figure 17 for application details.

TLFD500PN

3.3 V INTEGRATED G.LITE ANALOG FRONT END

SLAS207A – JUNE 1999 – REVISED NOVEMBER 1999

Terminal Functions

TERMINAL NAME	NO.	I/O	DESCRIPTION
AMP1INP– AMP4INP	11,2,66,59	I	Auxiliary amplifier 1–4 positive input
AMP1INM– AMP4INM	10,3,65,60	I	Auxiliary amplifier 1–4 negative input
AMP1OUTP– AMP2OUTP	9,4	O	Auxiliary amplifier 1–2 positive output. Outputs are self-biased to AVDD_TX/2.
AMP3OUTP– AMP4OUTP	64, 61	O	Auxiliary amplifier 3–4 positive output. Outputs are self-biased to AVDD_RX/2.
AMP1OUTM– AMP2OUTM	12,1	O	Auxiliary amplifier 1–2 negative output. Outputs are self-biased to AVDD_TX/2.
AMP3OUTM– AMP4OUTM	67,62	O	Auxiliary amplifier 3–4 negative output. Outputs are self-biased to AVDD_RX/2.
AVDD_REF	47	I	Analog supply for reference circuit
AVDD_RX	48,68	I	RX channel analog supply
AVDD_TX	7	I	TX channel analog supply
AVSS_REF	44	I	Analog supply return for reference(analog ground)
AVSS_RX	49,69	I	RX channel analog supply return (analog ground)
AVSS_TX	8	I	TX channel analog supply return (analog ground)
COMPDAC1	16	I	TX channel decoupling cap input A. Add 1 μ F capacitor to AVDD_TX
COMPDAC2	15	I	TX channel decoupling cap input B. Add 1 μ F capacitor to AVDD_TX
DGPO	35	O	Direct general-purpose output. This pin reflects the last value written to the DGPO bit location in the SDR data stream. It is a general-purpose output that does not require a secondary transfer to control.
DVDD	31,39	I	Digital power supply
DVDD_IO	32	I	Digital I/O buffer supply
DVDD_RX	51	I	RX channel digital supply
DVSS	34,40,41	I	Digital ground
DVSS_IO	33	I	Digital I/O buffer supply return (digital ground)
DVSS_RX	52,54,55, 56,57	I	RX channel digital supply return (digital ground)
FSX	22	O	Serial port frame sync transmit signal
FSR	21	O	Serial port frame sync receive signal
GPIO0–GPIO7	23–30	I/O	General-purpose I/O
HPF1INP	78	I	RX channel stage 1 amplifier positive input. Input signal needs to have AVDD_RX/2 common mode voltage.
HPF1INM	77	I	RX channel stage 1 amplifier negative input. Input signal needs to have AVDD_RX/2 common mode voltage.
HPF2INP	74	I	RX channel stage 2 positive input. Input signal need to have AVDD_RX/2 common mode voltage.
HPF2INM	73	I	RX channel stage 2 negative input. Input signal need to have AVDD_RX/2 common mode voltage.
HPF1OUTP	76	O	RX channel stage 1 amplifier positive output. Used to connect external components to obtain stage 1 HPF.
HPF1OUTM	79	O	RX channel stage 1 amplifier negative output. Used to connect external components to obtain stage 1 HPF.
HPF2OUTP	72	O	RX channel stage 2 positive output. Output signal has AVDD_RX/2 common mode voltage.
HPF2OUTM	75	O	RX channel stage 2 negative output. Output signal has AVDD_RX/2 common mode voltage.
MCLKIN/PLLCLKIN	37	I	Multiplexed pin based on value of PLLSEL. Selects master clock input, or clock input for PLL mode.



Terminal Functions (Continued)

TERMINAL NAME	NO.	I/O	DESCRIPTION
NC	36,53, 58, 63		No connection. Keep floating.
PLLSEL	42	I	Selects between VCXO mode and DPLL mode. If the pin is tied high PLL mode is selected. Pin should be tied low for VCXO mode. Cannot be left floating.
$\overline{\text{PWRDN}}$	17	I	Power-down pin. When $\overline{\text{PWRDN}}$ is pulled low the device goes into power-down mode. The default state of this pin is low.
REFM	45	O	Negative reference filter node. This terminal is provided for low-pass filtering of the internal band-gap reference. The optimal ceramic capacitor value is 10 μF (tantalum) and 0.1 μF (ceramic), connected to analog ground. The nominal dc voltage at this terminal is 0.5 V.
REFP	46	O	Positive reference filter node. This terminal is provided for low-pass filtering of the internal band-gap reference. The optimal ceramic capacitor value is 10 μF (tantalum) 0.1 μF (ceramic), connected to analog ground. The nominal dc voltage at this terminal is 2.5 V.
$\overline{\text{RESET}}$	38	I	Device reset input pin. Initializes all the device's internal registers to their default values. The default state of this pin is low.
RXBANDGAP	43	O	RX channel band-gap filter node. This terminal is provided for decoupling of the 1.5-V band-gap reference. The optimal capacitor value is 10 μF (tantalum) and 0.1 μF (ceramic). This node should not be used as a voltage source.
RXINP	70	I	RX channel stage 3 positive input. The input is self-biased at AVDD_RX/2.
RXINM	71	I	RX channel stage 3 negative input. The input is self-biased at AVDD_RX/2.
SCLK	19	O	Serial port shift clock (transmit and receive)
SDR	20	I	Serial data receive from DSP
SDX	18	O	Serial data transmit to DSP
TXBANDGAP	14	O	TX channel band-gap filter node. This terminal is provided for decoupling of the 1.5-V band-gap reference. The optimal capacitor value is 10 μF (tantalum) and 0.1 μF (ceramic). This node should not be used as a voltage source.
TXOUTP	5	O	TX channel positive output
TXOUTM	6	O	TX channel negative output
VCXOCNTL	13	O	DAC output to control onboard VCXO
VMID_RX	50	I/O	Decoupling Vmid for ADC. Add 10 μF (tantalum) and 0.1 μF (ceramic) capacitors to analog ground.
VSS	80	I	Substrate. Connect to analog ground.

detailed description

transmit

The transmit channel is powered by a high performance DAC. The transmit channel update rate is 276 kHz. The DAC is a 14-bit DAC at 4.416-MHz. This provides 16X oversampling. A band-pass filter limits the output of the transmitter to a frequency range of 30 kHz to 138 kHz. A differential amplifier drives the output into the external line driver. The differential amplifier has programmable attenuation for added flexibility. The transmitter high-pass filter can be bypassed by writing the appropriate bit to the filter bypass control register (BCR).

The output spectrum of the DAC complies with the nonoverlapped power spectrum density (PSD) mask specified in the ITU draft recommendation G.992.2 for G.Lite.

The TXPAA is a programmable-attenuation amplifier. It provides 0 dB to 24 dB of attenuation in 1-dB steps. The TXPAA is controlled via the PAA control register (PCR). For details about register programming see the register programming section.

TLFD500PN

3.3 V INTEGRATED G.LITE ANALOG FRONT END

SLAS207A – JUNE 1999 – REVISED NOVEMBER 1999

detailed description (continued)

receive

The receive channel consists of a high-pass filter, a programmable gain amplifier, an ADC, and filters. In addition, it has an equalizer to attain maximum system performance. The input of the receiver is fully differential.

The ADC in the receive channel is a 14-bit converter which samples at 4.416 Msps for 4X oversampling. An on-chip decimator reduces the sampling frequency to 1.104 MHz. The low pass filtering of the receive channel limits the converted data to frequencies below 552 kHz.

The high-pass analog filter is used to reject the near-end echo to maximize the dynamic range of the ADC. The high-pass filter consists of two stages: (1) a second order high-pass filter (HPF1) and, (2) a third order elliptic high-pass filter (HPF2). Both stages have a cutoff at 180 kHz. The filter is divided into two stages to minimize the noise from a single stage being amplified throughout. Together, the two high-pass filters typically attenuate the echo power by 30 dB. There is a programmable gain amplifier (PGA) between the two filters for coarse gain adjustments of 0-dB –12-dB in 3-dB steps. After the high-pass filter stage, the receiver channel has a 0-dB –18-dB PGA that can be adjusted in 6-dB steps. HPF2 and PGAs are integrated in one block. Figure 1(a), 1(b), and 1(c) show the frequency response of HPF1 and HPF2 (with PGAs).

The PGA is followed by a 552-kHz low-pass filter with a programmable 25-dB/MHz slope (5-dB/MHz step) equalizer incorporated. After the equalizer, there is a fine-gain adjustment PGA of 0-dB to 9-dB in 0.25-dB steps.

All the RX PGAs are controlled via the PGA control registers (PCR–RX1 and PCR–RX2). See the register programming section for details about register programming.



POST OFFICE BOX 655303 • DALLAS, TEXAS 75265

detailed description (continued)

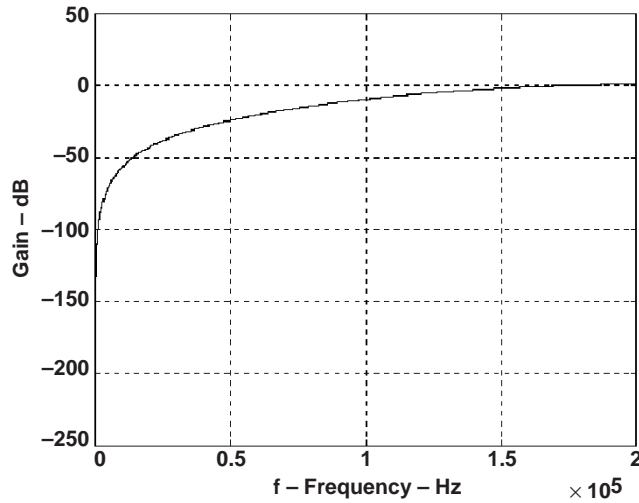

(a) RX-Stage HPF1 Frequency Response (0 to 200 kHz)

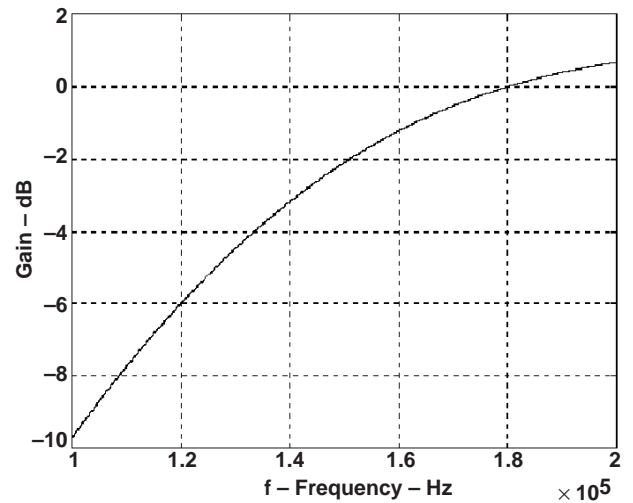

(b) RX-Stage HPF1 Frequency Response (100 kHz to 200 kHz)

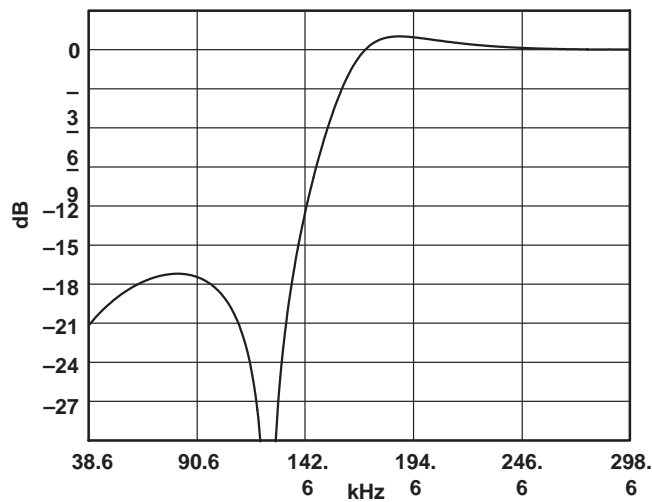

(c) RX-Stage HPF2 Frequency Response (PGA1 = PGA2 = 0 dB)

Figure 1. RX Stage HPF1 and HPF2 Frequency Response

clock control – VCXO mode

The VCXODAC uses a 12-bit, 2s complement number to control a 0-V to 3-V analog output. The two 8-bit registers, VCR-M and VCR-L, are used to generate the 12-bit control code (2s complement). This implies the use of 16 bits to obtain a 12-bit number.

VCR-M register occupy the most significant 8 bits in the 12-bit number and the lower 4 bits of the VCR-L register (VCR-L[3:0]) are used for the low 4 bits of the 12-bit number. The 12-bit code is updated every time either register is updated. VCR-L[7:4] must always be zero.

TLFD500PN

3.3 V INTEGRATED G.LITE ANALOG FRONT END

SLAS207A – JUNE 1999 – REVISED NOVEMBER 1999

clock control – DPLL mode

As an alternative to the VCXODAC and VCXO, an off-chip crystal oscillator (XO) followed by an on-chip digital PLL are also implemented. Refer to Figure 7 for an internal function block diagram. The input clock (35.328 MHz) goes to a programmable frequency divider to generate sampling clock for the ADC and DAC converters. By changing the divide ratio, the phase of the sampling clock can be adjusted. Setting PLLSEL (pin 42) high will enable the DPLL mode. Refer to DPLL section for detail.

clock generation

The clock generation block creates the necessary internal and external clocks needed by the device. All the clocks generated are produced from the CLKIN signal.

The following are recommended operational parameters for the external VCXO:

3.3-V supply, 35.328 MHz \pm 50 PPM center frequency, and input control voltage range of 0 V–3 V.
The recommended duty cycle is 50/50.

clock generation – SCLK

SCLK is an output and is used for serial data transfer. It runs at 35.328 MHz. Although SCLK and MCLK run at the same speed, there is no fixed phase relationship between them.

serial interface

The serial interface on the TLFD500PN connects directly to TI's C54x or C6x families of DSPs. The interface operates at 35.328 MHz. The serial port consists of five signals: SCLK, FSX, FSR, SDX, and SDR. A typical connection diagram is shown in Figure 2.

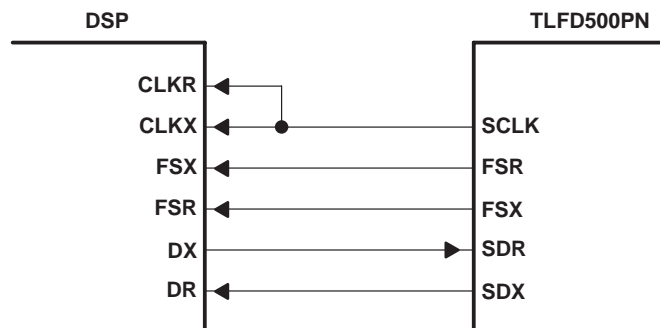

Figure 2. Typical Serial Port Connection

The serial port utilizes a primary/secondary scheme to transfer conversion data and control register data. A primary transfer scheme, used to transfer conversion data, occurs every conversion period. A secondary transfer scheme, used to transfer control data, happens only when requested by the host processor. The host processor requests a secondary transfer by using the LSB of the SDR data of the primary scheme. A value of 1 indicates a secondary transfer request. Once the secondary request is made and the primary transfer has been completed, secondary frame sync pulse (FSX/FSR) are transmitted to the host processor to indicate the beginning of the secondary transfer. The secondary FSX signal arrives 16 SCLKs after the primary FSX, and thus 48 SCLKs after the host processor request. This is because the span between FSX pulses for primary transfers is always 32 SCLKs. Each bit is read/written at the rising edge of the SCLK clock. Data bit mappings and example data transfers are shown in Table 1.

detailed description (continued)

Table 1. SDR LSB Control Function

CONTROL BIT D0	CONTROL BIT FUNCTION
0	No secondary transfer requested
1	Secondary transfer requested

primary transfer data mapping

The data bit mapping of a primary transfer is shown in Figure 3. Bits D2–D15 of the SDR data stream are DAC data. D1 is the control bit for the DGPO pin. The value written to this bit is reflected on the DGPO pin. See the timing diagram in Figures 5 and 6 for detailed timing information. D0 is the secondary transfer request bit. When a 1 is written to this bit, the host is requesting a secondary data transfer.

In the SDX data stream, D2–D15 contain the ADC conversion data. D0 and D1 can be set to reflect the values of GPIO1 and GPIO2. To set D0 and D1 to reflect the GPIO values, the proper bit in the MCR register needs to be set.

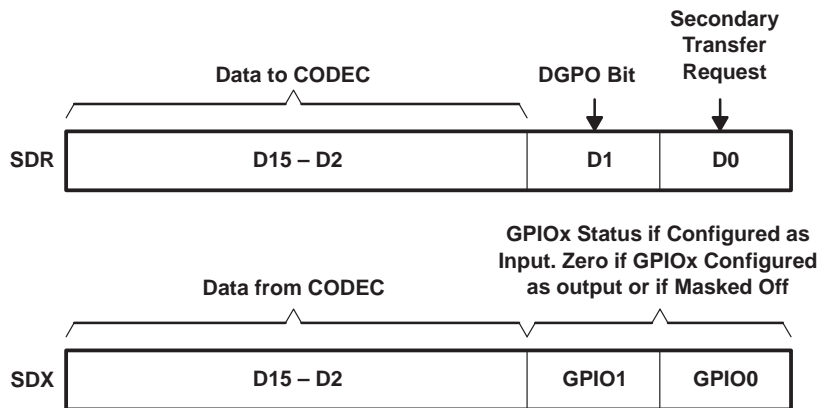

Figure 3. Primary Transfer Data Bit Mapping

secondary transfer data mapping

Secondary serial communication is used to configure the device. The data bit mapping for a secondary transfer is shown in Figure 4. Bits D10–D14 of the SDR data from the host contain the address of the control register involved in the transfer. D15 is a R/ \overline{W} bit. To read out the control register by the host processor, bit R/ \overline{W} must be set to 1. To write to the control register by the host processor, bit R/ \overline{W} must be set to 0. During a read operation, bits D0–D7 are don't care. For a write operation, bits D0–D7 contain the data for the register addressed by D10–D14. The eight bits of SDX always reflect the status of GPIO0–7.

If the secondary transfer is a read operation, the contents of the control register addressed by D10–D14 of the SDR data are reflected in bits D0–D7 of the SDX data stream. If the secondary transfer is a write operation, bits D0–D7 on SDX will be all zeroes.

TLFD500PN

3.3 V INTEGRATED G.LITE ANALOG FRONT END

SLAS207A – JUNE 1999 – REVISED NOVEMBER 1999

secondary transfer data mapping (continued)

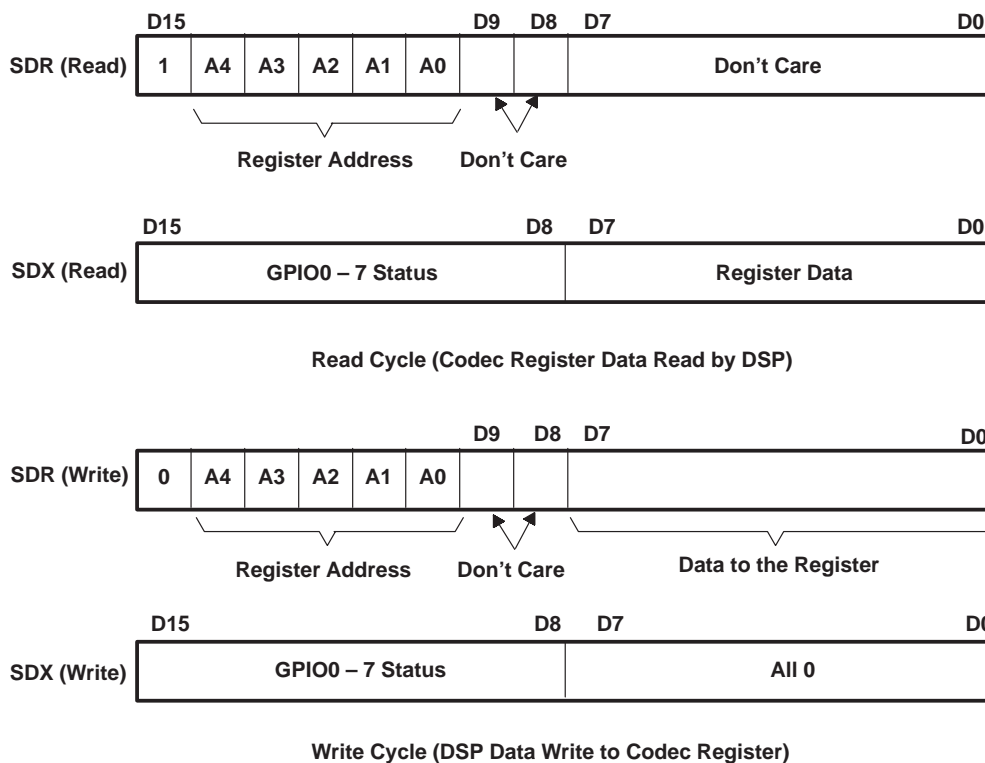

Figure 4. Secondary Transfer Data Bit Mapping

example data transfers

Figures 5(a) and 5(b) show the timing relationship for SCLK, FSX, SDX, FSR, and SDR in a primary communication. The timing sequence for this operation is as follows:

1. FS is set high and remains high during one SCLK period, then returns to low.
2. A 16-bit word is transmitted from the ADC (SDX), and a 16-bit word is received for DAC conversion (SDR).

Figure 6(a) and 6(b) shows the timing relationship with secondary request.

detailed description (continued)

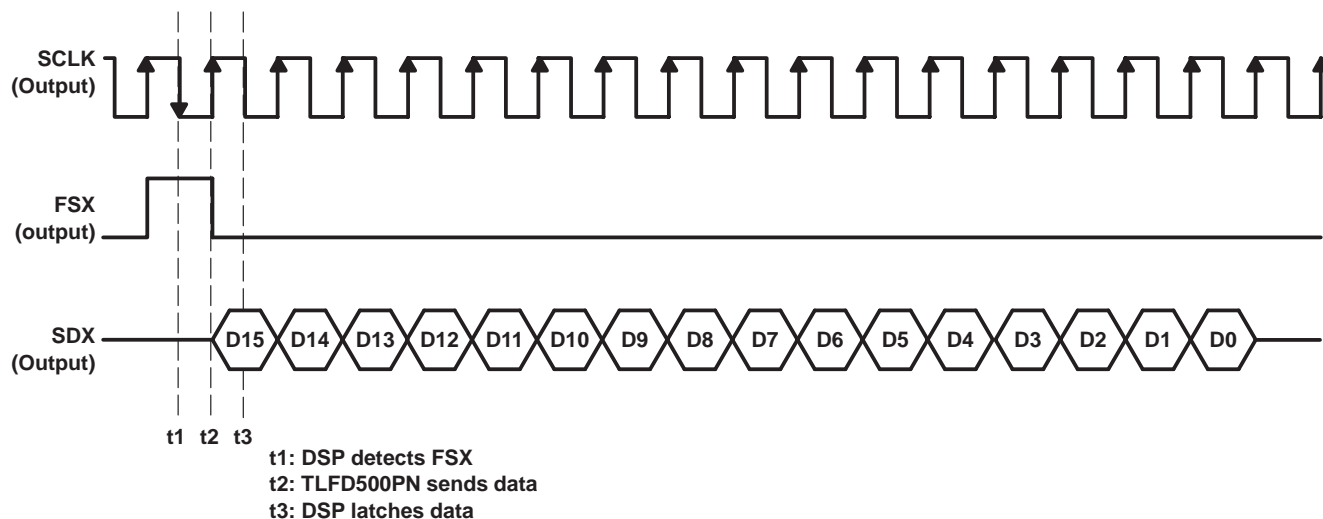

(a) TLF500PN to DSP

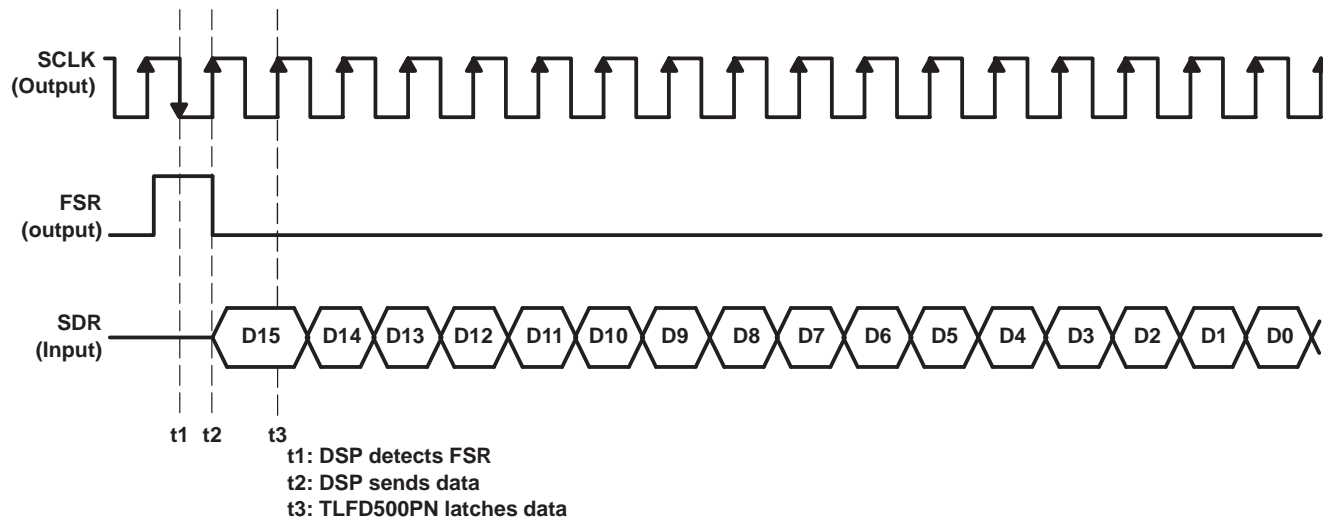

(b) DSP to TLF500PN

NOTE: TI DSP requires 10 ns after the positive edge of the SCLK to give the SDR data. This plus the board delay, output buffer (for SCLK) and input buffer delay (for SDR) to around 17 ns. As a consequence the SDR data can not be latched at the negative edge of SCLK.

Figure 5. Data Transfers

TLFD500PN
3.3 V INTEGRATED G.LITE ANALOG FRONT END

SLAS207A – JUNE 1999 – REVISED NOVEMBER 1999

detailed description (continued)

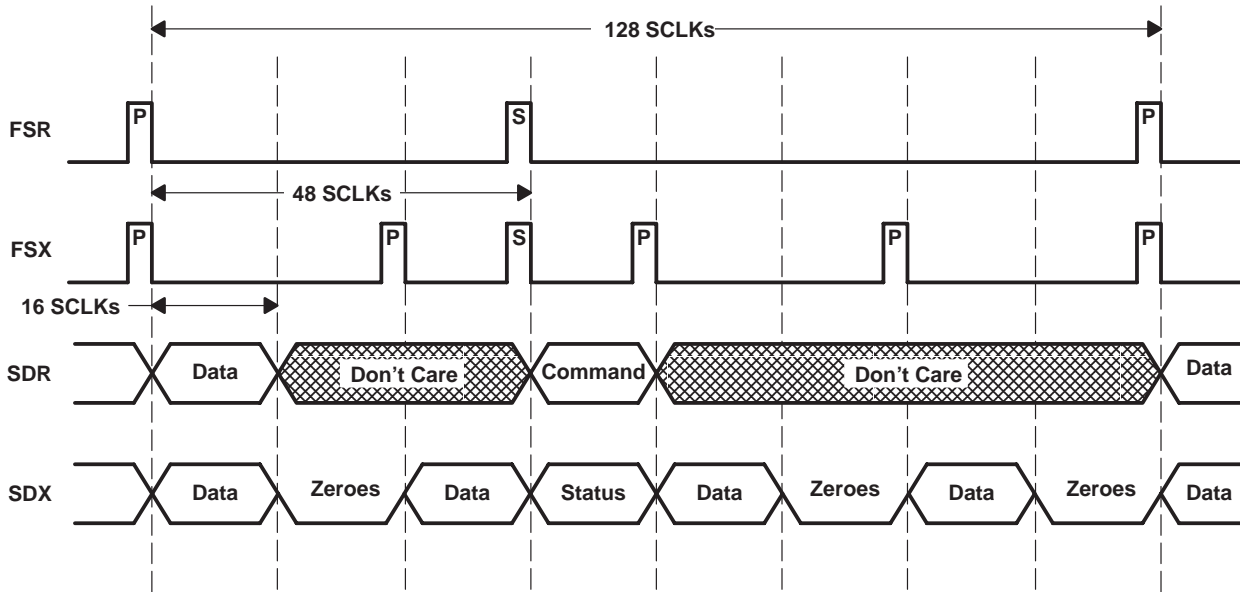

(a) With Secondary Request

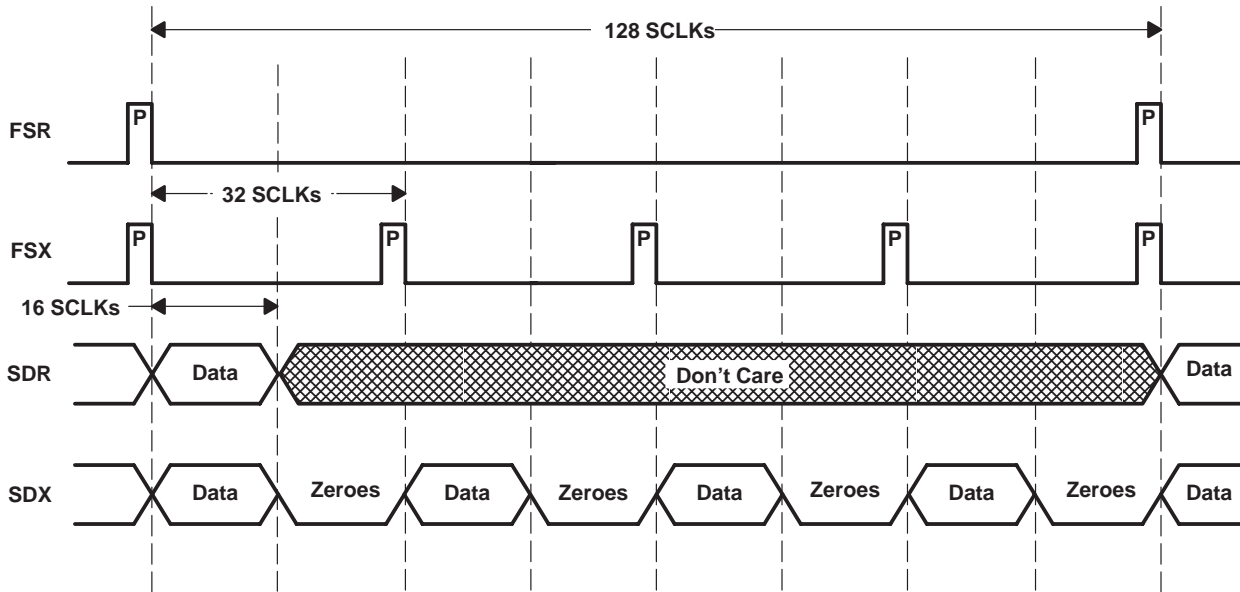

(b) Without Secondary Request

Figure 6. Data Transfers

detailed description (continued)

general purpose I/O port (GPIO)

The general-purpose I/O port provides eight input/output pins and one output-only pin for control of external circuitry, or for reading the status of external devices. The eight input/output pins are labeled GPIO0 –GPIO7. The output-only pin is labeled DGPO (direct general-purpose output). This pin is labeled as direct because a secondary transfer is not required to write to this pin.

The GPIO pins are controlled and read in the GPR-D register. The GPR-C register is used to configure the GPIO pins as input or output pins. The default reset condition is 11111111b, indicating that all are configured as inputs. For further details on register programming see the register programming section. The DGPO pin does not need configuring and is controlled by the D1 bit in the SDR data stream (that is, from the DSP to the TLFD500PN) during primary data transfers. In addition, a secondary transfer is not required to read GPIO0 and GPIO1 when they are configured as inputs. Their values can be mapped into the lower two bits of the SDX data stream (that is, from TLFD500PN to DSP) during primary data transfers. To map the values of GPIO0 and GPIO1 into the lower two bits of the SDX ADC data stream, set the appropriate bit in the MCR register.

For more flexibility, the values of GPIO0 – GPIO7 are mapped into the upper eight data bits of the SDX data stream on secondary data transfers. This allows the host processor to read the values of the GPIO pins and the contents of another control register during the same secondary data transfer. When a GPIO pin is being configured as an output, its corresponding status bit in the SDX data stream will be the last value written to the output pin.

Each output is capable of driving 2 mA.

reference system

The integrated reference provides voltage and current to the internal analog blocks. It is also brought out to external pins for noise decoupling. They should not be used as dc voltage source.

When the internal reference is being used by the device, the device may be powered down by writing the appropriate reference control bit in the main control register (MCR) to achieve power savings during periods of device inactivity.

auxiliary amplifiers

Four auxiliary high-performance operational amplifiers on the chip allow for additional onboard filtering and amplification with minimal component count. Each op-amp has differential inputs and outputs, with 2 input pins and 2 output pins. Each op-amp can be enabled by register programming.

The typical specifications for the operational amplifiers are as follows:

DC Gain:	126 dB
Bandwidth:	116 MHz
PSRR:	100 dB at dc, 70 dB at 1 MHz, and 40 dB at 4 MHz
Output common-mode:	AVDD_RX/2 (auxiliary amplifier 3,4) or AVDD_TX/2 (auxiliary amplifier 1,2)
Input interface:	AC coupled

device power-up sequence

All digital and analog supplies must be properly biased. All supply pins are mandatory. The power supply can not be switched, even when the codec has been powered down or parts of the codec are in power-down mode.

Reset must be held at least 20 μ s after power up. To reset the reference circuit and registers requires 100 ms. When the chip is woken up from hardware power-down mode, it takes 100 ms to reset the reference circuit before the chip works in normal mode. When the chip is woken up from software power-down mode, only 20 μ s is needed before valid data comes out (reference must be kept on). Register values will not change in either wake-up operation.

TLFD500PN

3.3 V INTEGRATED G.LITE ANALOG FRONT END

SLAS207A – JUNE 1999 – REVISED NOVEMBER 1999

detailed description (continued)

register programming

The codec registers are listed in Table 2, with each bit of each register defined. All registers are 8-bit wide.

NOTE:

Bits not defined in the table are reserved for future use. During a read, the reserved bit read value is not guaranteed. During a write, only zeroes can be written to reserved bits.

Table 2. Codec Registers

REGISTER		MODE	FUNCTION
NAME	ADDRESS A4 A3 A2 A1 A0		
BCR	00001	R/W	D0: Power-down RX HP filter 1 D1: Power-down RX HP filter 2 D2: Bypass TX digital HP filter D3: Echo mode: Echo SDR data back to SDX D4: Reserved D5: Reserved D6: Reserved
PCR-RX1	00010	R/W	D[5:0] = RXPGA3[5:0]; Fine gain, 0 to 9 dB, 0.25-dB steps
PCR-RX2	00011	R/W	D[2:0] = RXPGA1[2:0]; 0 to 12dB, 3-dB steps D[4:3] = RXPGA2[1:0]; 0 to 18 dB, 6-dB steps
PCR-TX	00100	R/W	D[4:0] = TX PAA[4:0]; 0 to -24dB, -1-dB steps
EQR	00101	R/W	D[2:0] = EQ[2:0] 0 to 25 dB, 5 dB/MHz steps; D[6:4] = EQ_PGA[2:0] 0 to 6 dB, 1 dB steps
VCR-M	00110	R/W	D[7:0] = VCXO DAC control Bit[11:4].
VCR-L	00111	R/W	D[3:0] = VCXO DAC control Bit[3:0]. D[7:4] must always be zero.
GPR-C	01000	R/W	D[7:0] = GPIO1 I/O control (0 = output, 1 = input)
GPR-D	01001	R/W	D[7:0] = GPIO data register
Reserved	01010	R/W	For future use. Read or write of register not allowed.
AUXR	01011	R/W	D0: Enable auxiliary amplifier 2 D1: Enable auxiliary amplifier 1 D2: Enable auxiliary amplifier 3 D3: Enable auxiliary amplifier 4
NCO_DEF	01100	R/W	D[7:0] = Default NCO divide number
NCO_DIV_DELAY	01101	R/W	D[7:0] = Number of samples, from current secondary transfer, after which effect of delta will occur.
NCO_DELTA	01110	R/W	D[7:4] = Delta from default for first sample of data frame (-8 through 7) D[3:0] = Number of times NCO divider remains changed from default before being set back to default (0 through 15)
MCR	01111	R/W	D0: S/W Power-down main reference D1: S/W Power-down TX channel with reference still on D2: S/W Power-down RX channel with reference still on D3: S/W Power-down VCXO with reference still on D4: S/W Reset D5: Analog loop back (refer to block diagram) D6: Digital loop back (refer to block diagram) D7: Enable GPIO 1 and 2 to show in SDX primary data



BCR – bypass control register

Address: 00001b

Contents at reset: 0000000b

D7	D6	D5	D4	D3	D2	D1	D0
Reserved	Reserved	Reserved	Reserved	ECHO	TXHPEN	RXHP2PD	RXHP1PD

Table 3. EQR Bit Definition

D7	D6	D5	D4	D3	D2	D1	D0	REG. VALUE	BIT NAME	DESCRIPTION
R	–	–	–	–	–	–	–	–	Reserved	Bit reserved for future use
–	R	–	–	–	–	–	–	–	Reserved	Bit reserved for future use
–	–	R	–	–	–	–	–	–	Reserved	Bit reserved for future use
–	–	–	R	–	–	–	–	–	Reserved	Bit reserved for future use
–	–	–	–	0	–	–	–	–	ECHO	Do not echo SDR data on SDX
–	–	–	–	1	–	–	–	0x08		Echo SDR data on SDX (see Note 1)
–	–	–	–	–	0	–	–	–	TXHPEN	Enable TX HP Filter
–	–	–	–	–	1	–	–	0x04		Bypass TX HP Filter
–	–	–	–	–	–	0	–	–	RXHP2PD	Power up RX HP Filter 2
–	–	–	–	–	–	1	–	0x02		Power down RX HP Filter 2
–	–	–	–	–	–	–	0	–	RXHP1PD	Power up RX HP Filter 1
–	–	–	–	–	–	–	1	0x01		Power down RX HP Filter 1

NOTE 1: ECHO mode allows for a quick verification of the serial interface operation. It sends back the data from input data buffer to the output data buffer and does not exercise the RX or TX channel.

TLFD500PN

3.3 V INTEGRATED G.LITE ANALOG FRONT END

SLAS207A – JUNE 1999 – REVISED NOVEMBER 1999

PCR-RX1 – programmable gain control register 1 for RX channel PGA3

Address: 00010b

Contents at reset: 0000000b

D7	D6	D5	D4	D3	D2	D1	D0
Reserved	Reserved	RXPGA3[5]	RXPGA3[4]	RXPGA3[3]	RXPGA3[2]	RXPGA3[1]	RXPGA3[0]

Table 4. PCR-RX1 Gain

D7	D6	D5	D4	D3	D2	D1	D0	HEX VALUE	BIT NAME	DESCRIPTION
R	–	–	–	–	–	–	–	–	Reserved	Bit reserved for future use
–	R	–	–	–	–	–	–	–	Reserved	Bit reserved for future use
–	–	0	0	0	0	0	0	0x00	RXPGA3[5:0]	0dB
–	–	0	0	0	0	0	1	0x01		0.25dB
–	–	0	0	0	0	1	0	0x02		0.50dB
–	–	0	0	0	0	1	1	0x03		0.75dB
–	–	0	0	0	1	0	0	0x04		1.00dB
–	–	0	0	0	1	0	1	0x05		1.25dB
–	–	0	0	0	1	1	0	0x06		1.50dB
–	–	0	0	0	1	1	1	0x07		1.75dB
–	–	0	0	1	0	0	0	0x08		2.00dB
–	–	0	0	1	0	0	1	0x09		2.25dB
–	–	0	0	1	0	1	0	0x0A		2.50dB
–	–	0	0	1	0	1	1	0x0B		2.75dB
–	–	0	0	1	1	0	0	0x0C		3.00dB
–	–	0	0	1	1	0	1	0x0D		3.25dB
–	–	0	0	1	1	1	0	0x0E		3.50dB
–	–	0	0	1	1	1	1	0x0F		3.75dB
–	–	0	1	0	0	0	0	0x10		4.00dB
–	–	0	1	0	0	0	1	0x11		4.25dB
–	–	0	1	0	0	1	0	0x12		4.50dB
–	–	0	1	0	0	1	1	0x13		4.75dB
–	–	0	1	0	1	0	0	0x14		5.00dB
–	–	0	1	0	1	0	1	0x15		5.25dB
–	–	0	1	0	1	1	0	0x16		5.50dB
–	–	0	1	0	1	1	1	0x17		5.75dB
–	–	0	1	1	0	0	0	0x18		6.00dB
–	–	0	1	1	0	0	1	0x19		6.25dB
–	–	0	1	1	0	1	0	0x1A		6.50dB
–	–	0	1	1	0	1	1	0x1B		6.75dB
–	–	0	1	1	1	0	0	0x1C		7.00dB
–	–	0	1	1	1	0	1	0x1D		7.25dB
–	–	0	1	1	1	1	0	0x1E		7.50dB
–	–	0	1	1	1	1	1	0x1F		7.75dB
–	–	1	0	0	0	0	0	0x20		8.00dB
–	–	1	0	0	0	1	1	0x21		8.25dB
–	–	1	0	0	1	0	0	0x22		8.50dB



Table 4. PCR-RX1 Gain (Continued)

D7	D6	D5	D4	D3	D2	D1	D0	HEX VALUE	BIT NAME	DESCRIPTION
–	–	1	0	0	0	1	1	0x23	RXPGA3[5:0]	8.75dB
–	–	1	0	0	1	0	0	0x24		9.00dB
–	–	1	0	0	1	0	1	0x25		INVALID
–	–	1	0	0	1	1	0	0x26		INVALID
–	–	1	0	0	1	1	1	0x27		INVALID
–	–	1	0	1	0	0	0	0x28		INVALID
–	–	1	0	1	0	0	1	0x29		INVALID
–	–	1	0	1	0	1	0	0x2A		INVALID
–	–	1	0	1	0	1	1	0x2B		INVALID
–	–	1	0	1	1	0	0	0x2C		INVALID
–	–	1	0	1	1	0	1	0x2D		INVALID
–	–	1	0	1	1	1	0	0x2E		INVALID
–	–	1	0	1	1	1	1	0x2F		INVALID
–	–	1	1	0	0	0	0	0x30		INVALID
–	–	1	1	0	0	0	1	0x31		INVALID
–	–	1	1	0	0	1	0	0x32		INVALID
–	–	1	1	0	0	1	1	0x33		INVALID
–	–	1	1	0	1	0	0	0x34		INVALID
–	–	1	1	0	1	0	1	0x35		INVALID
–	–	1	1	0	1	1	0	0x36		INVALID
–	–	1	1	0	1	1	1	0x37		INVALID
–	–	1	1	1	0	0	0	0x38		INVALID
–	–	1	1	1	0	0	1	0x39		INVALID
–	–	1	1	1	0	1	0	0x3A		INVALID
–	–	1	1	1	0	1	1	0x3B		INVALID
–	–	1	1	1	1	0	0	0x3C		INVALID
–	–	1	1	1	1	0	1	0x3D		INVALID
–	–	1	1	1	1	1	0	0x3E		INVALID
–	–	1	1	1	1	1	1	0x3F		INVALID

NOTE 2: The formula to convert bit value to RXPGA3 gain in dB is

$$\text{RXPGA3 gain (in dB)} = \text{RXPGA3[5:0]} \text{ (in decimal)} \times 0.25\text{dB}$$

Similarly one can compute the RXPGA3 [5:0] bit combination needed, given the gain in dB.

CAUTION:

Performance of the codec for invalid combination of bits is not guaranteed and such combinations should not be used. The user should make no assumption that the code bits will saturate to a maximum or minimum value or wrap around to a valid combination.

TLFD500PN

3.3 V INTEGRATED G.LITE ANALOG FRONT END

SLAS207A – JUNE 1999 – REVISED NOVEMBER 1999

PCR-RX2 – programmable gain control register 2 for RX channel PGA1 and PGA2

Address: 00011b Contents at reset: 0000000b

D7	D6	D5	D4	D3	D2	D1	D0
Reserved	Reserved	Reserved	RXPGA2[1]	RXPGA2[0]	RXPGA1[2]	RXPGA1[1]	RXPGA1[0]

Table 5. PCR-RX2 Gain

D7	D6	D5	D4	D3	D2	D1	D0	HEX VALUE	BIT NAME	DESCRIPTION
R	–	–	–	–	–	–	–	–	Reserved	Bit reserved for future use
–	R	–	–	–	–	–	–	–	Reserved	Bit reserved for future use
–	–	R	–	–	–	–	–	–	Reserved	Bit reserved for future use
–	–	–	0	0	–	–	–	0x00	RXPGA2[1:0]	0dB
–	–	–	0	1	–	–	–	0x08		6dB
–	–	–	1	0	–	–	–	0x10		12dB
–	–	–	1	1	–	–	–	0x18		18dB
–	–	–	–	–	0	0	0	0x00	RXPGA1[2:0]	0dB
–	–	–	–	–	0	0	1	0x01		3dB
–	–	–	–	–	0	1	0	0x02		6dB
–	–	–	–	–	0	1	1	0x03		9dB
–	–	–	–	–	1	0	0	0x04		12dB
–	–	–	–	–	1	0	1	0x05		INVALID
–	–	–	–	–	1	1	0	0x06		INVALID
–	–	–	–	–	1	1	1	0x07		INVALID

- NOTES: 3. The formula to convert bit value to RXPGA2 gain in dB is
 $RXPGA2 \text{ gain (in dB)} = RXPGA2[1:0] \text{ (in decimal)} \times 6\text{dB}$
 Similarly the needed RXPGA2[1:0] bit combination can be computed, given the gain in dB.
4. The formula to convert bit value to RXPGA1 gain in dB is
 $RXPGA1 \text{ gain (in dB)} = RXPGA1[2:0] \text{ (in decimal)} \times 3\text{dB}$
 Similarly the needed RXPGA1[2:0] bit combination can be computed, given the gain in dB.

CAUTION:

Performance of the codec for invalid combination of bits is not guaranteed and such combinations should not be used. The user should make no assumption that the code bits will saturate to a maximum or minimum value or wrap around to a valid combination.

PCR-TX – programmable attenuation control register for TX channel

Address: 00100b Contents at reset: 0000000b

D7	D6	D5	D4	D3	D2	D1	D0
Reserved	Reserved	Reserved	TXPAA[4]	TXPAA[3]	TXPAA[2]	TXPAA[1]	TXPAA[0]



PCR-TX – programmable attenuation control register for TX channel (continued)

Table 6. PCR-TX Attenuation

D7	D6	D5	D4	D3	D2	D1	D0	HEX VALUE	BIT NAME	DESCRIPTION
R	–	–	–	–	–	–	–	–	Reserved	Bit reserved for future use
–	R	–	–	–	–	–	–	–	Reserved	Bit reserved for future use
–	–	R	–	–	–	–	–	–	Reserved	Bit reserved for future use
–	–	–	0	0	0	0	0	0x00	TXPAA[4:0]	–0 dB
–	–	–	0	0	0	0	1	0x01		–1 dB
–	–	–	0	0	0	1	0	0x02		–2 dB
–	–	–	0	0	0	1	1	0x03		–3 dB
–	–	–	0	0	1	0	0	0x04		–4 dB
–	–	–	0	0	1	0	1	0x05		–5 dB
–	–	–	0	0	1	1	0	0x06		–6 dB
–	–	–	0	0	1	1	1	0x07		–7 dB
–	–	–	0	1	0	0	0	0x08		–8 dB
–	–	–	0	1	0	0	1	0x09		–9 dB
–	–	–	0	1	0	1	0	0x0A		–10 dB
–	–	–	0	1	0	1	1	0x0B		–11 dB
–	–	–	0	1	1	0	0	0x0C		–12 dB
–	–	–	0	1	1	0	1	0x0D		–13 dB
–	–	–	0	1	1	1	0	0x0E		–14 dB
–	–	–	0	1	1	1	1	0x0F		–15 dB
–	–	–	1	0	0	0	0	0x10		–16 dB
–	–	–	1	0	0	0	1	0x11		–17 dB
–	–	–	1	0	0	1	0	0x12		–18 dB
–	–	–	1	0	0	1	1	0x13		–19 dB
–	–	–	1	0	1	0	0	0x14		–20 dB
–	–	–	1	0	1	0	1	0x15		–21 dB
–	–	–	1	0	1	1	0	0x16		–22 dB
–	–	–	1	0	1	1	1	0x17		–23 dB
–	–	–	1	1	0	0	0	0x18		–24 dB
–	–	–	1	1	0	0	1	0x19		INVALID
–	–	–	1	1	0	1	0	0x1A		INVALID
–	–	–	1	1	0	1	1	0x1B		INVALID
–	–	–	1	1	1	0	0	0x1C		INVALID
–	–	–	1	1	1	0	1	0x1D		INVALID
–	–	–	1	1	1	1	0	0x1E		INVALID
–	–	–	1	1	1	1	1	0x1F		INVALID

NOTE 5: The formula to convert bit value to TXPAA attenuation in dB is

$$\text{TXPAA attenuation (in dB)} = \text{TXPAA}[4:0] \text{ (in decimal)} \times (-1)\text{dB}$$

Similarly one can compute the TXPAA[4:0] bit combination needed, given the attenuation in dB.

CAUTION:

Performance of the codec for invalid combination of bits is not guaranteed and such combinations should not be used. The user should make no assumption that the code bits will saturate to a maximum or minimum value or wrap around to a valid combination.



TLFD500PN

3.3 V INTEGRATED G.LITE ANALOG FRONT END

SLAS207A – JUNE 1999 – REVISED NOVEMBER 1999

EQR – equalizer slope and gain control register

Address: 00101b

Contents at reset: 00000000b

D7	D6	D5	D4	D3	D2	D1	D0
Reserved	EQPGA[2]	EQPGA[1]	EQPGA[0]	Reserved	EQ[2]	EQ[1]	EQ[0]

Table 7. EQR Slope and Gain

D7	D6	D5	D4	D3	D2	D1	D0	HEX VALUE	BIT NAME	DESCRIPTION
R	–	–	–	–	–	–	–	–	Reserved	Bit reserved for future use
–	0	0	0	–	–	–	–	0x00	EQPGA[2:0]	0dB
–	0	0	1	–	–	–	–	0x10		1dB
–	0	1	0	–	–	–	–	0x20		2dB
–	0	1	1	–	–	–	–	0x30		3dB
–	1	0	0	–	–	–	–	0x40		4dB
–	1	0	1	–	–	–	–	0x50		5dB
–	1	1	0	–	–	–	–	0x60		6dB
–	1	1	1	–	–	–	–	0x70		INVALID
–	–	–	–	R	–	–	–	–	Reserved	Bit reserved for future use
–	–	–	–	–	0	0	0	0x00	EQ[2:0]	0dB slope
–	–	–	–	–	0	0	1	0x01		5dB slope
–	–	–	–	–	0	1	0	0x02		10dB slope
–	–	–	–	–	0	1	1	0x03		15dB slope
–	–	–	–	–	1	0	0	0x04		20dB slope
–	–	–	–	–	1	0	1	0x05		25dB slope
–	–	–	–	–	1	1	0	0x06		INVALID
–	–	–	–	–	1	1	1	0x07		INVALID

- NOTES: 6. The formula to convert bit value to EQPGA gain in dB is
 $EQPGA \text{ gain (in dB)} = EQPGA[2:0] \text{ (in decimal)} \times 1 \text{ dB}$
 Similarly one can compute the EQPGA[2:0] bit combination needed, given the gain in dB.
7. The formula to convert bit value to EQ slope in dB is
 $EQ \text{ slope (in dB/MHz)} = EQ[2:0] \text{ (in decimal)} \times 5 \text{ dB/MHz}$
 Similarly one can compute the EQ[2:0] bit combination needed, given the slope in dB/MHz.

CAUTION:

Performance of the codec for invalid combination of bits is not guaranteed and such combinations should not be used. The user should make no assumption that the code bits will saturate to a maximum or minimum value or wrap around to a valid combination.



VCR-M – VCXO DAC control register MSB

Address: 00110b Contents at reset: 0000000b

D7	D6	D5	D4	D3	D2	D1	D0
VCR-M[7]	VCR-M[6]	VCR-M[5]	VCR-M[4]	VCR-M[3]	VCR-M[2]	VCR-M[1]	VCR-M[0]

VCR-L – VCXO DAC control register LSB

Address: 00111b Contents at reset: 0000000b

D7	D6	D5	D4	D3	D2	D1	D0
0	0	0	0	VCR-L[3]	VCR-L[2]	VCR-L[1]	VCR-L[0]

Table 8 shows some representative analog outputs.

Table 8. Representative Analog Outputs

OPERATION	HEX RESULT	ANALOG OUTPUT	COMMENTS
$VCR-M[7:0] * 2^4 + VCR-L[3:0]$	0x800	0 V	Min scale
	0x801	ΔV	Just above min

	0xFFFF	2047 ΔV	Just below mid
	0x000	2048 ΔV	Mid scale
	0x001	2049 ΔV	Just above mid

	0x7FE	4094 ΔV	Just below max
	0x7FF	4095 ΔV	Max scale

Where step-size, $\Delta = (3/4095)$ V.

For example, if 0xAA7 is desired, VCR-M and VCR-L should be set to 0xAA and 0x07;
if 0x539 is desired, VCR-M and VCR-L should be set to 0x53 and 0x09.

TLFD500PN

3.3 V INTEGRATED G.LITE ANALOG FRONT END

SLAS207A – JUNE 1999 – REVISED NOVEMBER 1999

GPR-C – GPIO I/O direction control register

Address: 01000b Contents at reset: 11111111b

D7	D6	D5	D4	D3	D2	D1	D0
GPIOC[7]	GPIOC[6]	GPIOC[5]	GPIOC[4]	GPIOC[3]	GPIOC[2]	GPIOC[1]	GPIOC[0]

Table 9. GPR-C Direction Control

D7	D6	D5	D4	D3	D2	D1	D0	REG VALUE	BIT NAME	DESCRIPTION
0	–	–	–	–	–	–	–	–	GPIOC[7]	Configure GPIO 7 pin as output
1	–	–	–	–	–	–	–	0x80		Configure GPIO 7 pin as input
–	0	–	–	–	–	–	–	–	GPIOC[6]	Configure GPIO 6 pin as output
–	1	–	–	–	–	–	–	0x40		Configure GPIO 6 pin as input
–	–	0	–	–	–	–	–	–	GPIOC[5]	Configure GPIO 5 pin as output
–	–	1	–	–	–	–	–	0x20		Configure GPIO 5 pin as input
–	–	–	0	–	–	–	–	–	GPIOC[4]	Configure GPIO 4 pin as output
–	–	–	1	–	–	–	–	0x10		Configure GPIO 4 pin as input
–	–	–	–	0	–	–	–	–	GPIOC[3]	Configure GPIO 3 pin as output
–	–	–	–	1	–	–	–	0x08		Configure GPIO 3 pin as input
–	–	–	–	–	0	–	–	–	GPIOC[2]	Configure GPIO 2 pin as output
–	–	–	–	–	1	–	–	0x04		Configure GPIO 2 pin as input
–	–	–	–	–	–	0	–	–	GPIOC[1]	Configure GPIO 1 pin as output
–	–	–	–	–	–	1	–	0x02		Configure GPIO 1 pin as input
–	–	–	–	–	–	–	0	–	GPIOC[0]	Configure GPIO 0 pin as output
–	–	–	–	–	–	–	1	0x01		Configure GPIO 0 pin as input

NOTE 8: A particular GPIOC control bit configures direction for the corresponding GPIOD data bit.

GPR-D – GPIO data register

Address: 01001b Contents at reset: 00000000b

D7	D6	D5	D4	D3	D2	D1	D0
GPIOD[7]	GPIOD[6]	GPIOD[5]	GPIOD[4]	GPIOD[3]	GPIOD[2]	GPIOD[1]	GPIOD[0]

CAUTION:
GPIOD[7:0] corresponds to pins GPIO7–GPIO0 respectively.



AUXR – auxiliary amplifier enable register

Address: 01011b Contents at reset: 0000000b

D7	D6	D5	D4	D3	D2	D1	D0
Reserved	Reserved	Reserved	Reserved	AMP4EN	AMP3EN	AMP1EN	AMP2EN

Table 10. Auxiliary Amplifier-Control

D7	D6	D5	D4	D3	D2	D1	D0	REG VALUE	BIT NAME	DESCRIPTION
R	–	–	–	–	–	–	–	–	Reserved	Bit reserved for future use
–	R	–	–	–	–	–	–	–	Reserved	Bit reserved for future use
–	–	R	–	–	–	–	–	–	Reserved	Bit reserved for future use
–	–	–	R	–	–	–	–	–	Reserved	Bit reserved for future use
–	–	–	–	0	–	–	–	–	AMP4EN	Disable amplifier 4
–	–	–	–	1	–	–	–	0x08		Enable amplifier 4
–	–	–	–	–	0	–	–	–	AMP3EN	Disable amplifier 3
–	–	–	–	–	1	–	–	0x04		Enable amplifier 3
–	–	–	–	–	–	0	–	–	AMP1EN	Disable amplifier 1
–	–	–	–	–	–	1	–	0x02		Enable amplifier 1
–	–	–	–	–	–	–	0	–	AMP2EN	Disable amplifier 2
–	–	–	–	–	–	–	1	0x01		Enable amplifier 2

CAUTION:

Performance of the codec for invalid combination of bits is not guaranteed and such combinations should not be used. The default condition is with the amplifiers switched off.

NCO_DEF – numerically controlled oscillator default value register

Address: 01100b Contents at reset: 0100000b (64 decimal)

D7	D6	D5	D4	D3	D2	D1	D0
Reserved	NCDEF[6]	NCDEF[5]	NCDEF[4]	NCDEF[3]	NCDEF[2]	NCDEF[1]	NCDEF[0]

Table 11. NCO Default Value Table

D7	D6	D5	D4	D3	D2	D1	D0	HEX VALUE	BIT NAME	DESCRIPTION
R	–	–	–	–	–	–	–	–	Reserved	Bit reserved for future use
–	0	0	0	0	0	0	0	0x00	NCDEF[7:0]	Decimal 0, INVALID
–	0x01 – 0x2E		Decimal 1 to 46, INVALID
–	0	1	0	1	1	1	1	0x2F		Decimal 47, INVALID
–	0	1	1	0	0	0	0	0x30		Decimal 48, INVALID
–	0x31 – 0x5C		Decimal 49 to 92, VALID
–	1	0	1	1	1	0	1	0x5D		Decimal 93, INVALID
–	1	0	1	1	1	1	0	0x5E		Decimal 94, INVALID
–	0x5F – 0xFF		Decimal 95 onwards, INVALID

CAUTION:

The sum NCDEF[7:0] + NCDEL[3:0] should always be between 48 and 93. Out-of-bound values should not be used.

TLFD500PN

3.3 V INTEGRATED G.LITE ANALOG FRONT END

SLAS207A – JUNE 1999 – REVISED NOVEMBER 1999

NCO_DIV_DELAY – numerically controlled oscillator delay control register

Address: 01101b Contents at reset: 0000000b

D7	D6	D5	D4	D3	D2	D1	D0
NCDLY[7]	NCDLY[6]	NCDLY[5]	NCDLY[4]	NCDLY[3]	NCDLY[2]	NCDLY[1]	NCDLY[0]

Table 12. NCO Default Value

D7	D6	D5	D4	D3	D2	D1	D0	HEX VALUE	BIT NAME	DESCRIPTION
0	0	0	0	0	0	0	0	0x00	NCDLY[7:0]	INVALID
0	0	0	0	0	0	0	1	0x01		INVALID
0	0	0	0	0	0	1	0	0x02		ADCLK jittered 2 sample clocks (of ADCLK) after write into the NCO_DIV_DELAY register (see Note 10)
...	0x03 – 0xFD		Jitter after 3 to 253 sample clocks (All individual values are valid)
1	1	1	1	1	1	1	0	0xFE		Jitter after 254 sample clocks
1	1	1	1	1	1	1	1	0xFF		Jitter after 255 sample clocks

- NOTES: 9. The formula to convert NCDLY[7:0] to delay is straightforward.
 Delay (number of ADCLK periods) = NDCLK[7:0] (except for 0 and 1).
 10. ADCLK=A/D converter sampling clock

CAUTION:

This register is also the only means of communicating to the codec that the ADCLK must be jittered. Thus not writing a value implies that jitter will not take place even if other registers have non-default values. As a side consequence, this register does not remember its value. All the others store them unless RESET.

Writing 0 or 1 is not recommended

examples:

1. NCDEF[7:0] = 64 (dec.), NCDEL[4:0] = 1, NCRPT[2:0] = 2, NCDLY[7:0] = 5. This shows a default division value of 64, giving a normal ADCLK of 2.208 MHz (assuming 35.328 MHz input); the division ratio will be 64 + 1 = 65 to effect the jitter, that is, pulling in the clock phase. The jitter will be repeated for 2 consecutive samples. The jitter will take effect 5 ADCLK sample periods after writing to NCDLY.
2. NCDEF[7:0] = 63 (decimal), NCDEL[4:0] = -1, NCRPT[2:0] = 2, NCDLY[7:0] = 5. Similar to 1. The default frequency is slightly less than 2.208 MHz. Since the division ratio is 63 - 1 = 62, the clock phase is pushed out.
3. NCDEF[7:0] = 64 (decimal), NCDEL[4:0] = 0, NCRPT[2:0] = 2, NCDLY[7:0] = 5. Here the jitter will not be observed, since the delta register is zero.
4. NCDEF[7:0] = 64 (decimal), NCDEL[4:0] = 1, NCRPT[2:0] = 0, NCDLY[7:0] = 5. Here the jitter will not be observed, since the repeat register is zero.
5. NCDEF[7:0] = 64 (decimal), NCDEL[4:0] = 1, NCRPT[2:0] = 2, NCDLY[7:0] = 0. This is invalid and not recommended. NCDLY[7:0] can not be 0 or 1.
6. NCDEF[7:0] = 64 (decimal), NCDEL[4:0] = 1, NCRPT[2:0] = 2. Here the jitter will not occur since there was not writing to NCDLY. The other registers will retain their values as in all other cases.



NCO_DELTA – numerically controlled oscillator delta value register

Address: 01110b

Contents at reset: 0000000b

D7	D6	D5	D4	D3	D2	D1	D0
NCDEL[3]	NCDEL[2]	NCDEL[1]	NCDEL[0]	NCRPT[3]	NCRPT[2]	NCRPT[1]	NCRPT[0]

Table 13. NCO_DELTA – DELTA and REPEAT

D7	D6	D5	D4	D3	D2	D1	D0	HEX VALUE	BIT NAME	DESCRIPTION
0	0	0	0	–	–	–	–	0x00	NCDEL[3:0]	DELTA = 0
0	0	0	1	–	–	–	–	0x08		DELTA = 1
0	0	1	0	–	–	–	–	0x10		DELTA = 2
0	0	1	1	–	–	–	–	0x18		DELTA = 3
0	1	0	0	–	–	–	–	0x20		DELTA = 4
0	1	0	1	–	–	–	–	0x28		DELTA = 5
0	1	1	0	–	–	–	–	0x30		DELTA = 6
0	1	1	1	–	–	–	–	0x38		DELTA = 7
1	0	0	0	–	–	–	–	0x40		DELTA = –8
1	0	0	1	–	–	–	–	0x48		DELTA = –7
1	0	1	0	–	–	–	–	0x50		DELTA = –6
1	0	1	1	–	–	–	–	0x58		DELTA = –5
1	1	0	0	–	–	–	–	0x60		DELTA = –4
1	1	0	1	–	–	–	–	0x68		DELTA = –3
1	1	1	0	–	–	–	–	0x70		DELTA = –2
1	1	1	1	–	–	–	–	0x78		DELTA = –1
–	–	–	–	0	0	0	0	0x00	NCRPT[3:0]	REPEAT = 0 (same as DELTA = 0)
–	–	–	–	0	0	0	1	0x01		REPEAT = 1
–	–	–	–	0	0	1	0	0x02		REPEAT = 2
–	–	–	–	0	0	1	1	0x03		REPEAT = 3
–	–	–	–	0	1	0	0	0x04		REPEAT = 4
–	–	–	–	0	1	0	1	0x05		REPEAT = 5
–	–	–	–	0	1	1	0	0x06		REPEAT = 6
–	–	–	–	0	1	1	1	0x07		REPEAT = 7
–	–	–	–	1	0	0	0	0x08		REPEAT = 8
–	–	–	–	1	0	0	1	0x09		REPEAT = 9
–	–	–	–	1	0	1	0	0x0A		REPEAT = 10
–	–	–	–	1	0	1	1	0x0B		REPEAT = 11
–	–	–	–	1	1	0	0	0x0C		REPEAT = 12
–	–	–	–	1	1	0	1	0x0D		REPEAT = 13
–	–	–	–	1	1	1	0	0x0E		REPEAT = 14
–	–	–	–	1	1	1	1	0x0F	REPEAT = 15	

TLFD500PN

3.3 V INTEGRATED G.LITE ANALOG FRONT END

SLAS207A – JUNE 1999 – REVISED NOVEMBER 1999

MCR – master control register

Address: 01111b Contents at reset: 0000000b

D7	D6	D5	D4	D3	D2	D1	D0
GP12EN	DLBEN	ALBEN	SWRST	VCDACPD	RXPD	TXPD	SWREFPD

Table 14. MCR Control

D7	D6	D5	D4	D3	D2	D1	D0	REG VALUE	BIT NAME	DESCRIPTION
0	–	–	–	–	–	–	–	–	GP12EN	No effect on SDX
1	–	–	–	–	–	–	–	0x80		Show GPIO 1 and 2 in SDX primary.
–	0	–	–	–	–	–	–	–	DLBEN	No effect on digital loop back
–	1	–	–	–	–	–	–	0x40		Enable digital loop back
–	–	0	–	–	–	–	–	–	ALBEN	No effect on analog loop back
–	–	1	–	–	–	–	–	0x20		Enable analog loop back
–	–	–	0	–	–	–	–	–	SWRST	No effect on reset
–	–	–	1	–	–	–	–	0x10		Perform soft reset
–	–	–	–	0	–	–	–	–	VCDACPD	Power up VCXODAC
–	–	–	–	1	–	–	–	0x08		Power down VCXODAC
–	–	–	–	–	0	–	–	–	RXPD	Power up RX channel
–	–	–	–	–	1	–	–	0x04		Power down RX channel
–	–	–	–	–	–	0	–	–	TXPD	Power up TX channel
–	–	–	–	–	–	1	–	0x02		Power down TX channel
–	–	–	–	–	–	–	0	–	SWREFPD	Power up (soft) main reference
–	–	–	–	–	–	–	1	0x01		Power down (soft) main reference

- NOTES: 11. The SWRST and SWREFPD refer to the word software, since the reset is done by register programming as opposed to hard resets done by forcing pin logic levels.
12. Analog loop-back means looping back of the analog TX output to the RX input. This way the codec can be tested without need of external analog sources.
13. Digital loop-back means looping back the digital RX output to the TX input. Here we can test the code without the need for a DSP and serial data transfer.

CAUTION:

All power downs of VCXODAC, RX, and TX channels occur with the reference still on.

DPLL detailed description

The default value of register NCO_DEF is 64. With the 35.328 MHz input clock, the output frequency of the PLL is $4 \times 35.328 = 141.312$ MHz. To obtain an ADC clock of 2.208 MHz the divide ratio (controlled by register NCO_DEF) needs to be 64. Increasing or decreasing this ratio (for example, 65 or 63) can effect a temporary phase shift. The ratio is controlled by the DSP through register programming.

In DPLL mode, the ADC clock (ADCLK) will work at 2.208 MHz instead of the 4.416 MHz used in the VCXO mode. The DAC clock (DACLK) will continue to work at 4.416 MHz. When the ADCLK is jittered, the DACLK is also jittered.



DPLL detailed description (continued)

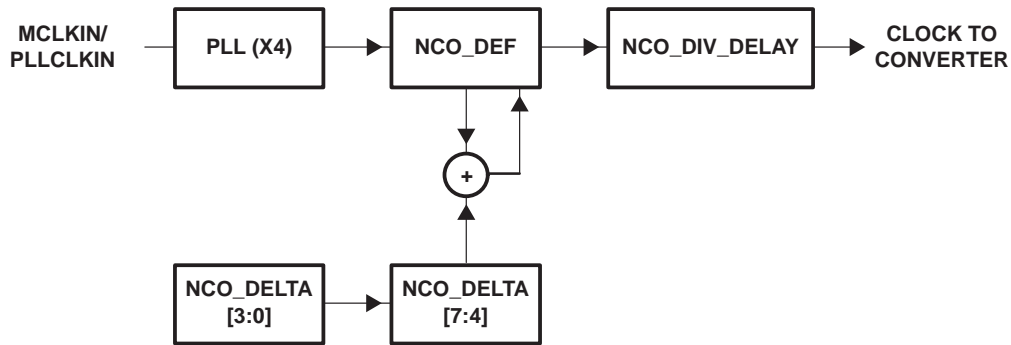

Figure 7. DPLL Internal Function Block Diagram

Example: Assume MCLKIN/PLLCLKIN=35.328 MHz. When NCO_DEF is programmed as 64, a 2.208 MHz clock is provided to the ADC converter according to the following formula:

$$35.328 \times 4/64 = 2.208$$

If NCO_DELTA [7:4] is set to -1, NCO_DELTA [3:0] is set to 3, and NCO_DIV_DELAY is set to 2 (NCO_DIV_DELAY should be the last register to be programmed), register NCO_DEF will change to 63,63,63,64 at the beginning of the third sampling period. Each number (63 or 64) only last one clock (2.208 MHz) cycle. And the combination 63,63,63,64 occurs only once. Reprogramming of register NCO_DIV_DELAY is needed if further adjustment is required.

Figure 7 shows the timing of SCLK with the following setting:

- NCO_DELTA [7:4] = 1 (Delta)
- NCO_DELTA [3:0] = 1 (Repeat)
- NCO_DIV_DELAY = 2 (Delay)

Also note that in DPLL mode, the ADC clock will work at 2.208 MHz, 2 times oversampled, (instead of 4.416 MHz used in the VCXO mode) and the DAC clock will continue to work at 4.416 MHz.

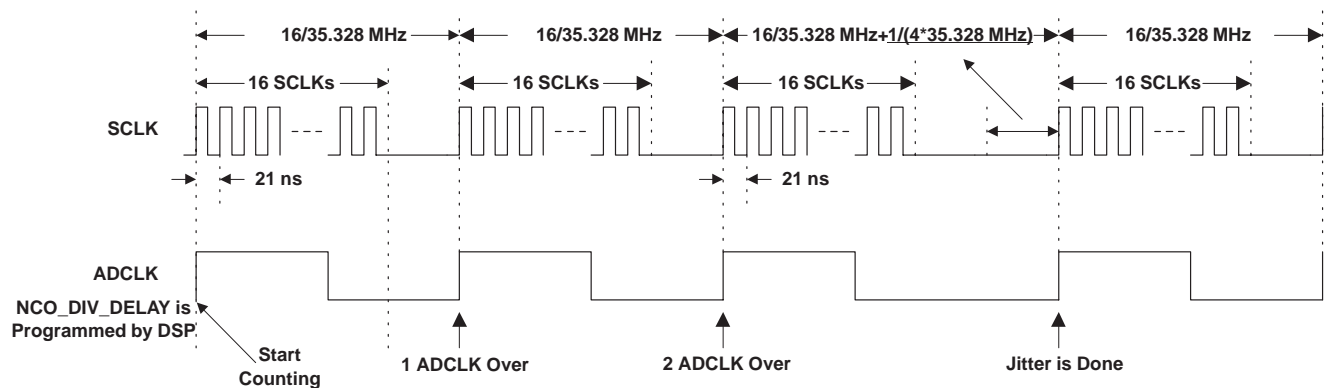

Figure 8. ADCLK Jitter Example

TLFD500PN

3.3 V INTEGRATED G.LITE ANALOG FRONT END

SLAS207A – JUNE 1999 – REVISED NOVEMBER 1999

DPLL detailed description (continued)

To prevent variation in the serial clock width (SCLK) due to jitter, the serial clock is modified to have a fixed high level of 14 ns and a low level of 7 ns, thus resulting in a period of 21 ns. The average clock frequency is still 35.328 MHz. After the 16 SCLKs are complete, the clock goes quiet (no toggle zone) until the rising edge of the next ADCLK. The length of the *no-toggle zone* varies with the ADCLK. Figure 9 illustrates an example.

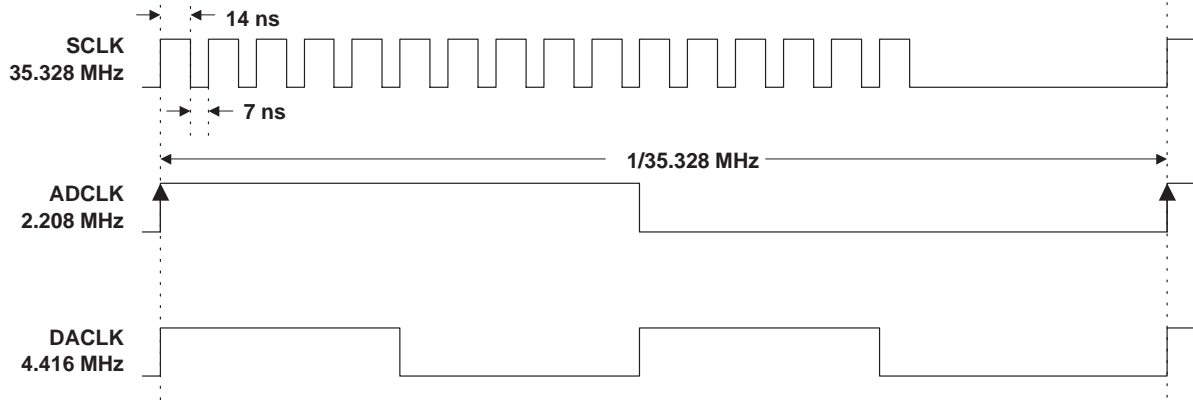

Figure 9. Relation of SCLK With ADCLK/DACLK in DPLL Mode

absolute maximum ratings over operating free-air temperature (unless otherwise noted)†

Supply voltage, AVDD to AGND, DVDD to DGND	–0.3 V to 4.5 V
Analog input voltage range to AGND	–0.3 V to AVDD+0.3 V
Digital input voltage range	–0.3 V to DVDD+0.3 V
Operating virtual junction temperature range, T_J	–40°C to 150°C
Operating free-air temperature range, T_A	–40°C to 85°C
Storage temperature range, T_{Str}	–65°C to 150°C
Lead temperature 1,6 mm (1/16 inch) from case for 10 seconds	250°C

† Stresses beyond those listed under “absolute maximum ratings” may cause permanent damage to the device. These are stress ratings only, and functional operation of the device at these or any other conditions beyond those indicated under “recommended operating conditions” is not implied. Exposure to absolute-maximum-rated conditions for extended periods may affect device reliability.

recommended operating conditions

power supply

		MIN	NOM	MAX	UNIT
Supply voltage	AVDD_RX, AVDD_TX, AVDD_REF	3	3.3	3.6	V
	DVDD, DVDD_IO, DVDD_RX	3	3.3	3.6	

digital inputs

		MIN	NOM	MAX	UNIT
High-level input voltage, V_{IH}	Digital power supply = 3.3 V	2.4			V
Low-level input voltage, V_{IL}				0.6	

analog input

		MIN	NOM	MAX	UNIT
Analog input signal range	AVDD_RX = 3.3 V, The input signal is measured single ended.	AVDD_RX/2±0.75			V
	AVDD_RX = 3.3 V, The input signal is measured differentially.	3			V _{p-p}



recommended operating conditions (continued)

clock

	MIN	NOM	MAX	UNIT
Input clock frequency		35.328		MHz
Input clock duty cycle		50%		

electrical characteristics over recommended operating free-air temperature range, $f_{MCLKIN} = 35.328$ MHz, $AVDD_RX/AVDD_TX/AVDD_REF = 3.3$ V, $DVDD = DVDD_IO = DVDD_RX = 3.3$ V, (unless otherwise noted)

TX channel (measured differentially)

PARAMETER	TEST CONDITIONS	MIN	TYP	MAX	UNIT
Gain error		-1.5		1.5	dB
PAA step gain error			±0.25		dB
DC offset			50	100	mV
Cross-talk	RX to TX channel		-70		dB
Idle channel noise			65		μVrms
Group delay			30		μs
Power supply rejection ratio (PSRR)	200 mVp-p at 75 kHz		70		dB
Analog output voltage	Load = 2000 Ω		3		Vp-p
AC Performance					
SNR	Signal-to-noise ratio		70		dB
THD	Total harmonic distortion ratio	70 kHz at -1 dB (see Note 14)		75	dB
TSNR	Signal-to-noise + harmonic distortion ratio		68		dB
MT	Missing-tone test (see Note 15)	30.1875 kHz	-71		dB
		81.9375 kHz	-71		
		129.375 kHz	-71		
Channel Frequency Response (Refer to Figure 13)					
Filter gain relative to gain at 77.625 kHz	30 kHz	-1.5		1.5	dB
	Pass-band (ripple)	-1		1	
	180 kHz		-70		

NOTES: 14. The input signal is the digital equivalent of a sine wave (digital full scale = 0 dB). The normal differential output with this input condition is 3 V_{pp}.

15. 27 tones, 25.875 to 138 kHz, 4.3125 kHz/step, 0 dB

reference outputs

	MIN	NOM	MAX	UNIT
REFP	2.2	2.5	2.8	V
REFM	0.3	0.5	0.7	V
TXBANDGAP	1.4	1.5	1.6	V
RXBANDGAP	1.4	1.5	1.6	V
VMID_RX		1.5		V

digital outputs

	MIN	NOM	MAX	UNIT
V _{OH} High-level output voltage		2.4		V
V _{OL} Low-level output voltage			0.6	

TLFD500PN

3.3 V INTEGRATED G.LITE ANALOG FRONT END

SLAS207A – JUNE 1999 – REVISED NOVEMBER 1999

**electrical characteristics over recommended operating free-air temperature range,
 $f_{MCLKIN} = 35.328$ MHz, AVDD_RX/AVDD_TX/AVDD_REF = 3.3 V, DVDD = DVDD_IO = DVDD_RX = 3.3 V, (unless otherwise noted) (continued)**

RX channel (measured differentially)

PARAMETER	TEST CONDITIONS	MIN	TYP	MAX	UNIT
Gain error		-1.5		1.5	dB
PGA step gain error	PGA 1 (0 to 12 dB in 3-dB steps)		±1		dB
	PGA 2 (0 to 18 dB in 6-dB steps)		±1		
	PGA 3 (0 to 9 dB in 0.25-dB steps)		±0.15		
DC offset			50	100	mV
Cross-talk	TX to RX channel		-55		dB
Group delay			25		μs
Idle-channel noise			100		μVrms
Common-mode rejection ratio (CMRR)			70		dB
Power supply rejection ratio (PSRR)	200 mVp-p at 75 kHz		70		dB
Analog input self-bias dc voltage			1.5		V
Input impedance	RXINP/M		7		kΩ
	HPF1INP/M		70		pF
	HPF2INP/M		70		pF
AC Performance					
SNR	Signal-to-noise ratio		72		dB
THD	Total harmonic distortion ratio	270 kHz at -1 dB (see Note 16)	82		
TSNR	Signal-to-noise + harmonic distortion ratio		72		
MT	Missing-tone test (see Note 17)	163.875 kHz	-57		dB
		301.875 kHz	-57		
		508.875 kHz	-57		
Channel Frequency Response (EQ[2:0] = 0 dB/MHz) (Refer to Figures 15 and 16)					
Filter gain relative to gain at 276 kHz	180 kHz	-1.5		1.5	dB
	Pass-band (ripple)	-1		1	
	800 kHz		-25		

NOTES: 16. The analog input test signal is a sine wave with 0 dB = 3 Vp-p as the reference level.

17. 123 tones, 25.875 kHz to 552 kHz, 4.3125 kHz/step, -6 dB.



electrical characteristics over recommended operating free-air temperature range,
 $f_{MCLKIN} = 35.328$ MHz, AVDD_RX/AVDD_TX/AVDD_REF = 3.3 V, DVDD = DVDD_IO = DVDD_RX = 3.3 V, (unless otherwise noted) (continued)

VCXO DAC

PARAMETER		TEST CONDITIONS	MIN	TYP	MAX	UNIT
Resolution				12		Bits
DNL	Differential nonlinearity				±1	LSB
INL	Integral nonlinearity				±4	LSB
Monotonicity					12	Bits
Channel gain error						dB
Offset error			-100		100	mV
Analog Output						
Full scale output voltage		Load = 50 kΩ, V _{DD} = 3.3 V		3		V
Output load				50		kΩ

power dissipation

				MIN	TYP	MAX	UNIT
Power dissipation	Active mode				700	850	mW
	Power-down mode		Hardware power down		50	100	
			Software power down	TX only			mW
				RX only			
				TX + RX + Reference			

TLFD500PN

3.3 V INTEGRATED G.LITE ANALOG FRONT END

SLAS207A – JUNE 1999 – REVISED NOVEMBER 1999

timing requirements over recommended ranges of supply voltage and operating free-air temperature (unless otherwise noted)

serial port (see Figures 7 and 8) and DGPO (see Figure 9)

PARAMETER		MIN	TYP	MAX	UNIT
t_{c1}	Period, SCLK		28.3		ns
t_{d1}	Delay time, FSR high before SCLK↓	7			ns
t_{d2}	Delay time, FSR high after SCLK↓	7			ns
t_{d3}	Delay time, FSX high before SCLK↓	7			ns
t_{d4}	Delay time, FSX high after SCLK↓	7			ns
t_{d5}	Delay time, SDX data valid after SCLK↑			7	ns
t_{d6}	Delay time, GPIO becomes valid after data is sent			7	ns
t_f	Falling time, SCLK change from high to low			4.4	ns
t_{h1}	Hold time, SDR keep valid after SCLK↑	2			ns
t_r	Rising time, SCLK change from low to high			4.6	ns
t_{su1}	Setup time, SDR valid before SCLK↑	6			ns

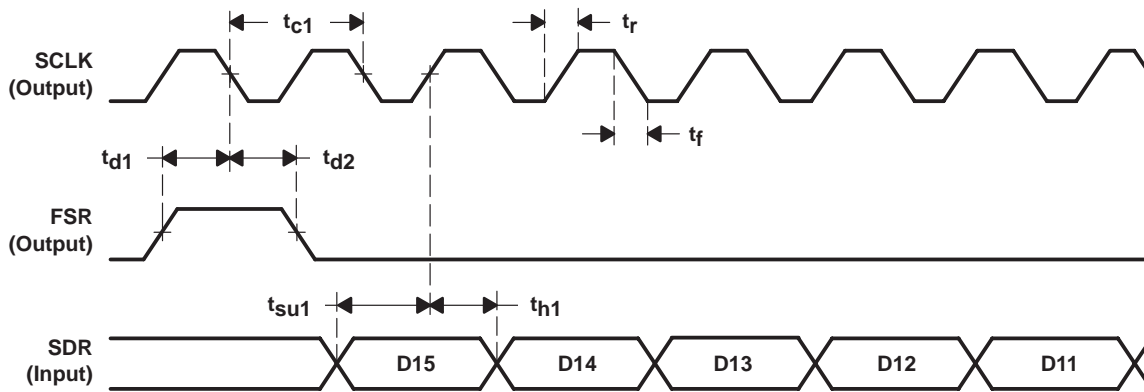

Figure 10. Data Transfers From DSP to TLFD500PN

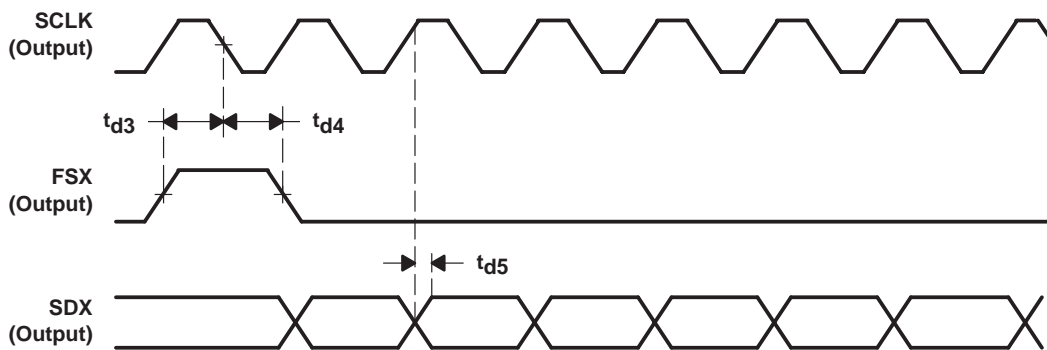

Figure 11. Data Transfers From TLFD500PN to DSP

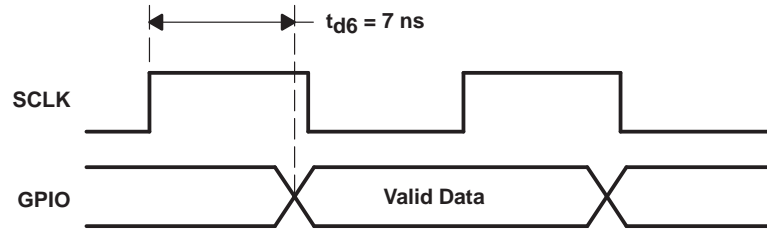

Figure 12. GPIO Bit-to-Pin Update Timing

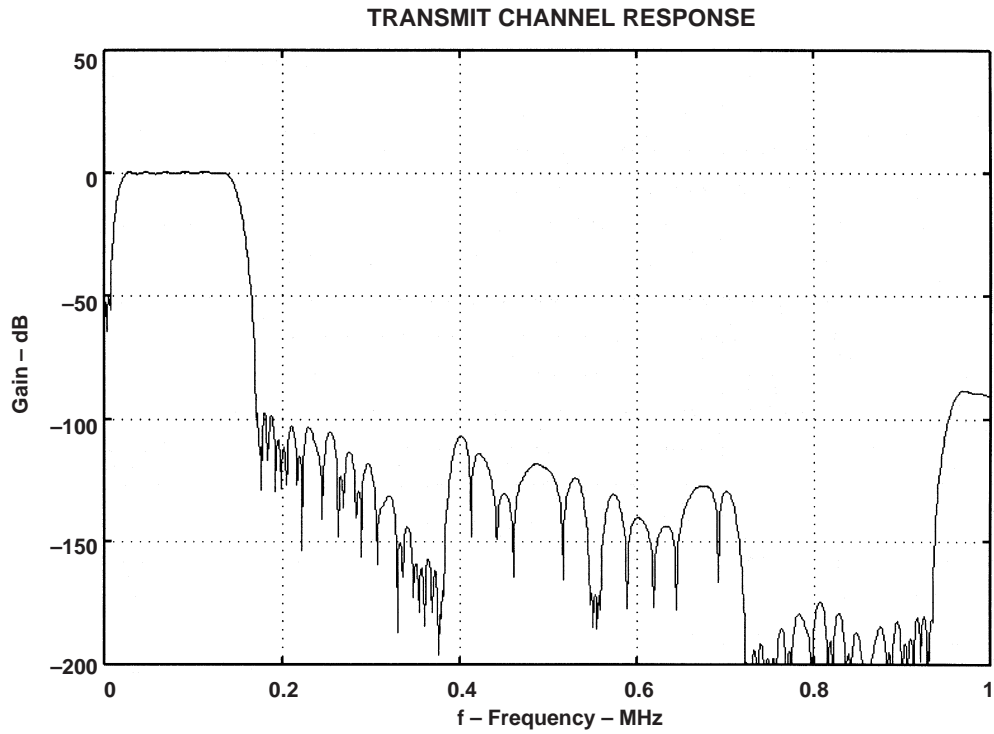

Figure 13. Transfer Characteristic of the Transmit Filters
(Complies with ITU G.992.2 PSD requirement)

TLFD500PN 3.3 V INTEGRATED G.LITE ANALOG FRONT END

SLAS207A – JUNE 1999 – REVISED NOVEMBER 1999

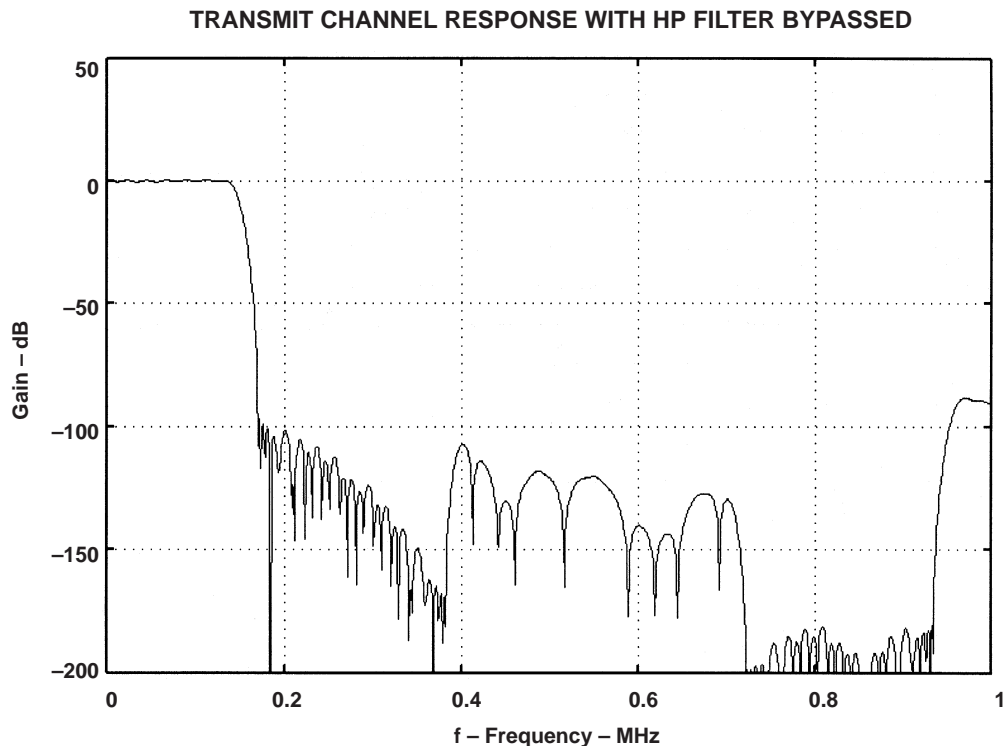

Figure 14. Transfer Characteristic of the Transmit Filters With HP Filter Bypassed (Complies with ITU G.992.2 PSD requirement)

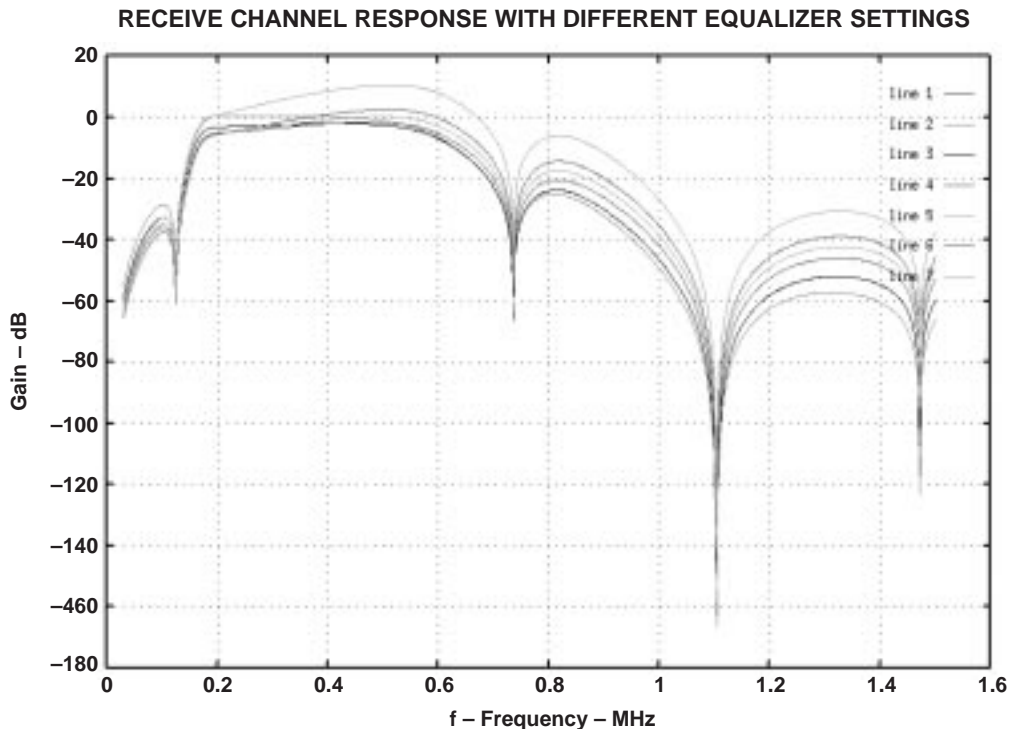

Figure 15. Transfer Characteristic of the Receive Filters (including out of band 0–1.6 MHz) (Complies with ITU G.992.2 PSD requirement)

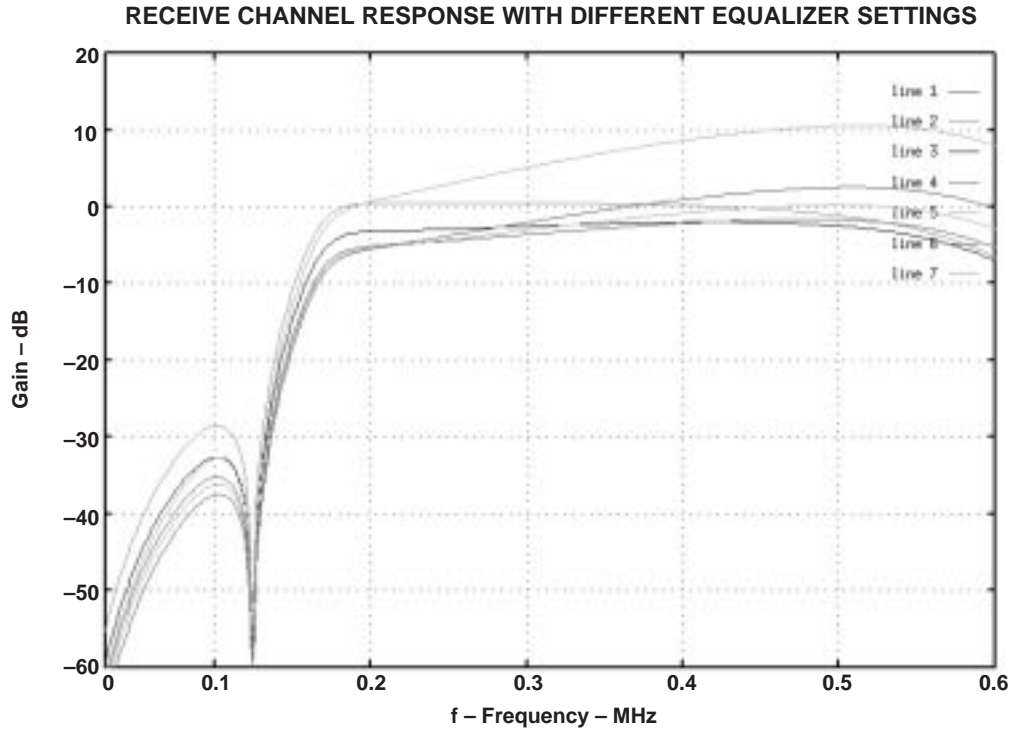

Figure 16. Transfer Characteristic of the Receive Filters (in-band 0–0.6 MHz)
(Complies with ITU G.992.2 PSD requirement)

TLFD500PN

3.3 V INTEGRATED G.LITE ANALOG FRONT END

SLAS207A – JUNE 1999 – REVISED NOVEMBER 1999

APPLICATION INFORMATION

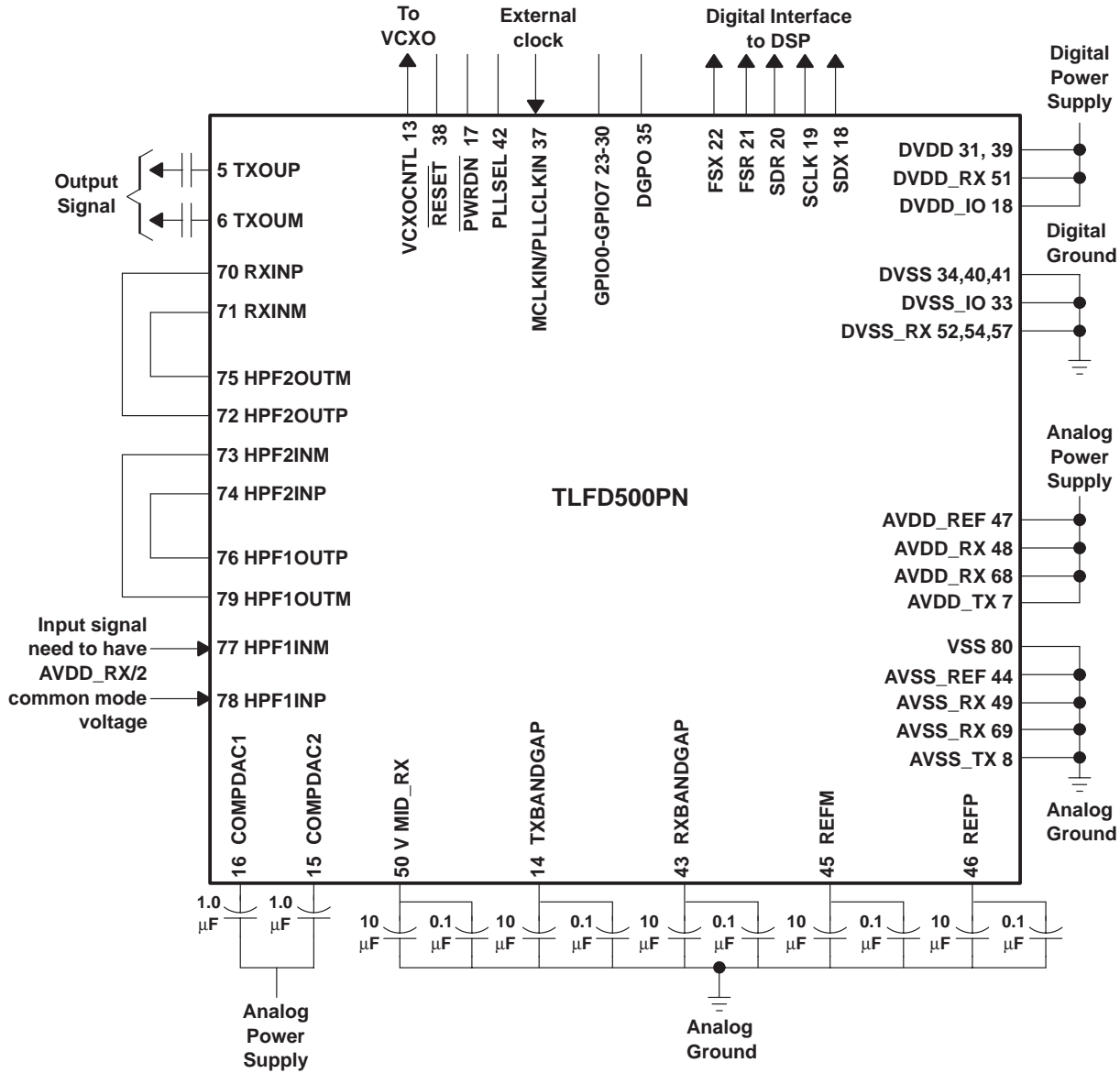

Figure 17. Typical Application Circuit

TLFD500PN
3.3 V INTEGRATED G.LITE ANALOG FRONT END

SLAS207A – JUNE 1999 – REVISED NOVEMBER 1999

MECHANICAL DATA

PN (S-PQFP-G80)

PLASTIC QUAD FLATPACK

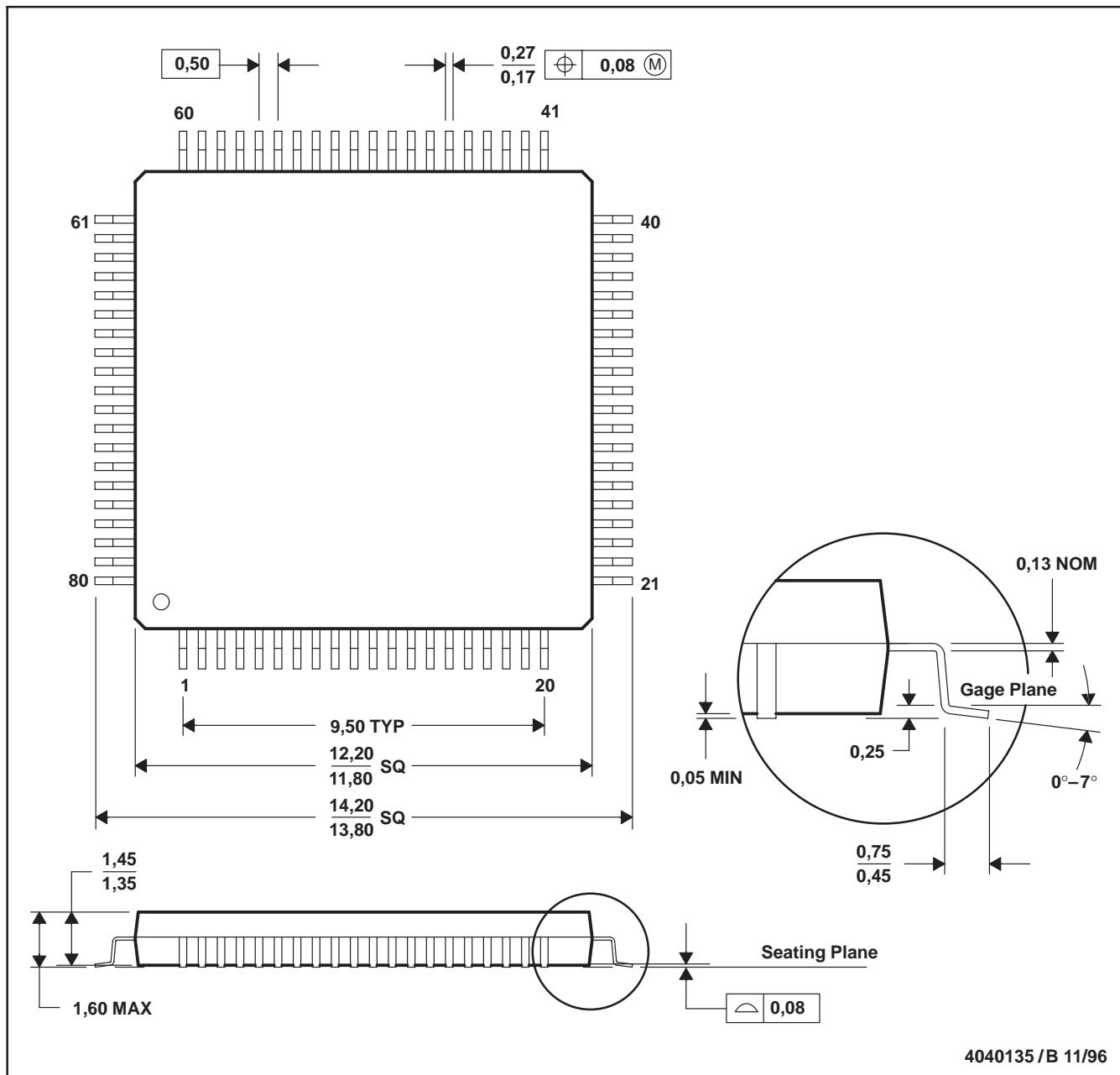

NOTES: A. All linear dimensions are in millimeters.
B. This drawing is subject to change without notice.
C. Falls within JEDEC MS-026

IMPORTANT NOTICE

Texas Instruments and its subsidiaries (TI) reserve the right to make changes to their products or to discontinue any product or service without notice, and advise customers to obtain the latest version of relevant information to verify, before placing orders, that information being relied on is current and complete. All products are sold subject to the terms and conditions of sale supplied at the time of order acknowledgement, including those pertaining to warranty, patent infringement, and limitation of liability.

TI warrants performance of its semiconductor products to the specifications applicable at the time of sale in accordance with TI's standard warranty. Testing and other quality control techniques are utilized to the extent TI deems necessary to support this warranty. Specific testing of all parameters of each device is not necessarily performed, except those mandated by government requirements.

CERTAIN APPLICATIONS USING SEMICONDUCTOR PRODUCTS MAY INVOLVE POTENTIAL RISKS OF DEATH, PERSONAL INJURY, OR SEVERE PROPERTY OR ENVIRONMENTAL DAMAGE ("CRITICAL APPLICATIONS"). TI SEMICONDUCTOR PRODUCTS ARE NOT DESIGNED, AUTHORIZED, OR WARRANTED TO BE SUITABLE FOR USE IN LIFE-SUPPORT DEVICES OR SYSTEMS OR OTHER CRITICAL APPLICATIONS. INCLUSION OF TI PRODUCTS IN SUCH APPLICATIONS IS UNDERSTOOD TO BE FULLY AT THE CUSTOMER'S RISK.

In order to minimize risks associated with the customer's applications, adequate design and operating safeguards must be provided by the customer to minimize inherent or procedural hazards.

TI assumes no liability for applications assistance or customer product design. TI does not warrant or represent that any license, either express or implied, is granted under any patent right, copyright, mask work right, or other intellectual property right of TI covering or relating to any combination, machine, or process in which such semiconductor products or services might be or are used. TI's publication of information regarding any third party's products or services does not constitute TI's approval, warranty or endorsement thereof.