

# Cree® XLamp® XR-E LED Data Sheet

Cree XLamp LEDs combine the brightness of power LED chips with a rugged package capable of operating up to four watts. Cree XLamp LEDs lead the solid-state lighting industry in brightness while providing a reflow-solderable design that is optimized for ease of use and thermal management. Lighting applications featuring XLamp LEDs maximize light output and increase design flexibility, while minimizing environmental impact.

Cree XLamp LEDs bring lighting-class brightness and efficiency to a wide range of lighting and backlighting applications, including portable lighting and flashlights, outdoor and industrial, signaling, architectural, landscaping and entertainment/advertising installations.

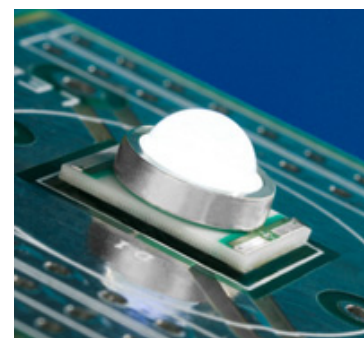

## FEATURES

- Guaranteed minimum flux order codes up to 100 lm in white and 23.5 lm in blue
- Over 80 lm/W available in white
- Available in white (2,600 K to 10,000 K CCT), blue and royal blue
- Drive currents: 350 to 1000 mA
- Industry's lowest thermal resistance: 8°C/W
- Max junction temperature: 150°C
- Industry-leading JEDEC standard pre-qualification testing
- Reflow solderable – JEDEC J-STD-020C compatible
- Electrically neutral thermal path
- RoHS-compliant
- Lumen maintenance of greater than 70% after 50,000 hours

## Table of Contents

<b>Flux Characteristics (<math>T_j = 25^\circ\text{C}</math>)</b> .....	<b>2</b>
<b>Characteristics</b> .....	<b>3</b>
<b>Relative Spectral Power</b> .....	<b>4</b>
<b>Photometric Output vs. Junction Temperature (<math>I_f = 350\text{ mA}</math>)</b> .....	<b>5</b>
<b>Electrical Characteristics (<math>T_j = 25^\circ\text{C}</math>)</b> .....	<b>6</b>
<b>Thermal Design</b> .....	<b>6</b>
<b>Relative Intensity vs. Current (<math>T_j = 25^\circ\text{C}</math>)</b> .....	<b>7</b>
<b>Typical Spatial Radiation Pattern</b> .....	<b>7</b>
<b>Reflow Soldering Characteristics</b> .....	<b>8</b>
<b>Notes</b> .....	<b>9</b>
<b>Mechanical Dimensions (<math>T_A = 25^\circ\text{C}</math>)</b> .....	<b>10</b>
<b>Tape and Reel</b> .....	<b>11</b>
<b>Dry Packaging and Packaging</b> .....	<b>12</b>

## Flux Characteristics (T<sub>j</sub> = 25°C)

The following tables describe the available colors and flux for XR-E LEDs by listing the correlated color temperature or dominant wavelength range for the entire family and by providing several base order codes. It is important to note that the base order codes listed here are a subset of the total available order codes for the product family. For more order codes, as well as a complete description of the order-code nomenclature, please consult the XR-E & XR-C Binning and Labeling document.

Color	CCT Range		Base Order Codes Min Luminous Flux (lm)		Order Code
	Min.	Max.	Group	Flux (lm)	
Cool White	5,000 K	10,000 K	N4	62.0	XREWHT-L1-0000-00601
			P2	67.2	XREWHT-L1-0000-00701
			P3	73.9	XREWHT-L1-0000-00801
			P4	80.6	XREWHT-L1-0000-00901
			Q2	87.4	XREWHT-L1-0000-00A01
			Q3	93.9	XREWHT-L1-0000-00B01
Neutral White	3,700 K	5,000 K	N4	62.0	XREWHT-L1-0000-006E4
			P2	67.2	XREWHT-L1-0000-007E4
			P3	73.9	XREWHT-L1-0000-008E4
			N3	56.8	XREWHT-L1-0000-005E7
Warm White	2,600 K	3,700 K	N4	62.0	XREWHT-L1-0000-006E7

Color	Dominant Wavelength Range				Base Order Codes Min Luminous Flux (lm)		Order Code
	Min.		Max.		Group	Flux (lm)	
	Group	DWL (nm)	Group	DWL (nm)			
Blue	B3	465	B6	485	H0	18.1	XREBLU-L1-0000-00H01
					J0	23.5	XREBLU-L1-0000-00J01

Color	Dominant Wavelength Range				Base Order Codes Min Radiant Flux (mW)		Order Code
	Min.		Max.		Group	Flux (mW)	
	Group	DWL (nm)	Group	DWL (nm)			
Royal Blue	D3	450	D5	465	12	250	XREROY-L1-0000-00701
					13	300	XREROY-L1-0000-00801

### Notes:

- Cree maintains a tolerance of +/- 7% on flux and power measurements.
- Typical CRI for Cool White & Neutral White (3,700 K – 10,000 K CCT) is 75.
- Typical CRI for Warm White (2,600 K – 3,700 K CCT) is 80.



## Characteristics

Characteristics	Unit	Minimum	Typical	Maximum
Thermal Resistance, junction to solder point	°C/W		8	
Viewing Angle (FWHM)	degrees		90	
Temperature coefficient of voltage (white, blue, royal blue)	mV/°C		-4.0	
ESD Classification (HBM per Mil-Std-883D)			Class 2	
DC Forward Current (white ≥ 5000 K)	mA			1000
DC Forward Current (white < 5000 K, blue, royal blue)	mA			700
DC Pulse Current (@ 1 kHz, 10% duty cycle)	A			1.8
Reverse Voltage	V			5
Forward Voltage (@ 350 mA)	V		3.3	3.9
Forward Voltage (@ 700 mA)	V		3.5	
Forward Voltage (@ 1000 mA) (white ≥ 5000 K)	V		3.7	
LED Junction Temperature *	°C			150

\* Note: For lumen maintenance data, see the Cree XLamp LED Reliability document.

**Relative Spectral Power**

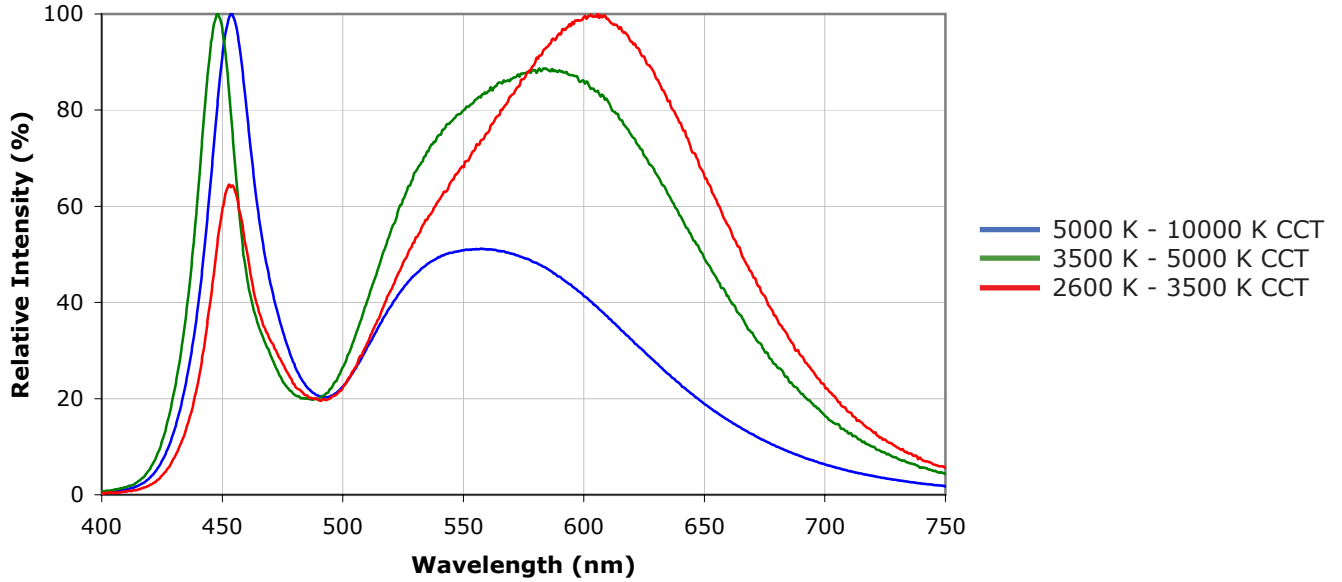

**White**

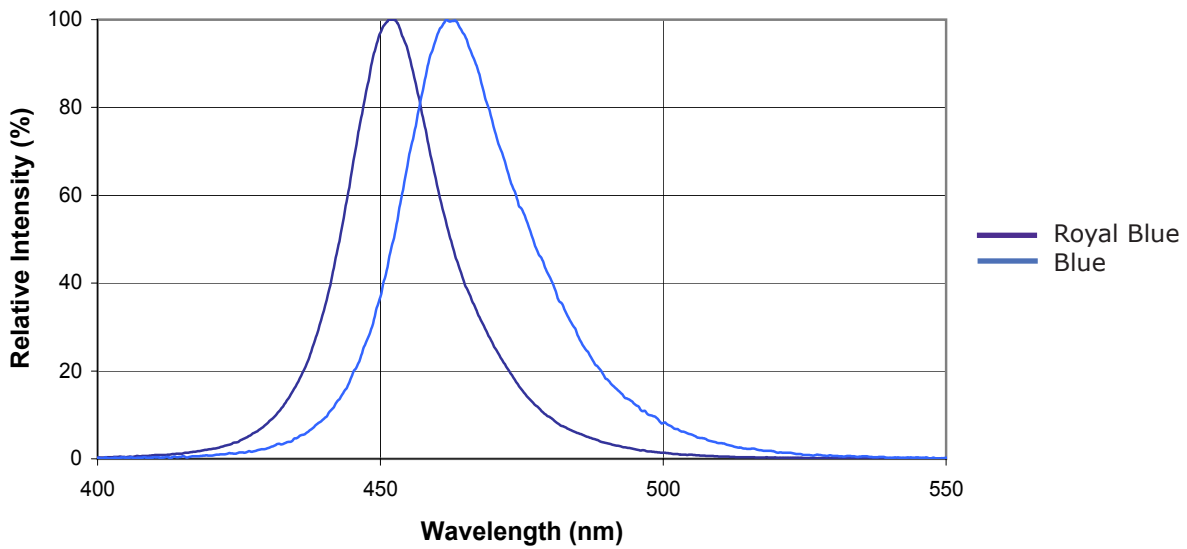

**Blue**

**Photometric Output vs. Junction Temperature ( $I_F = 350 \text{ mA}$ )**

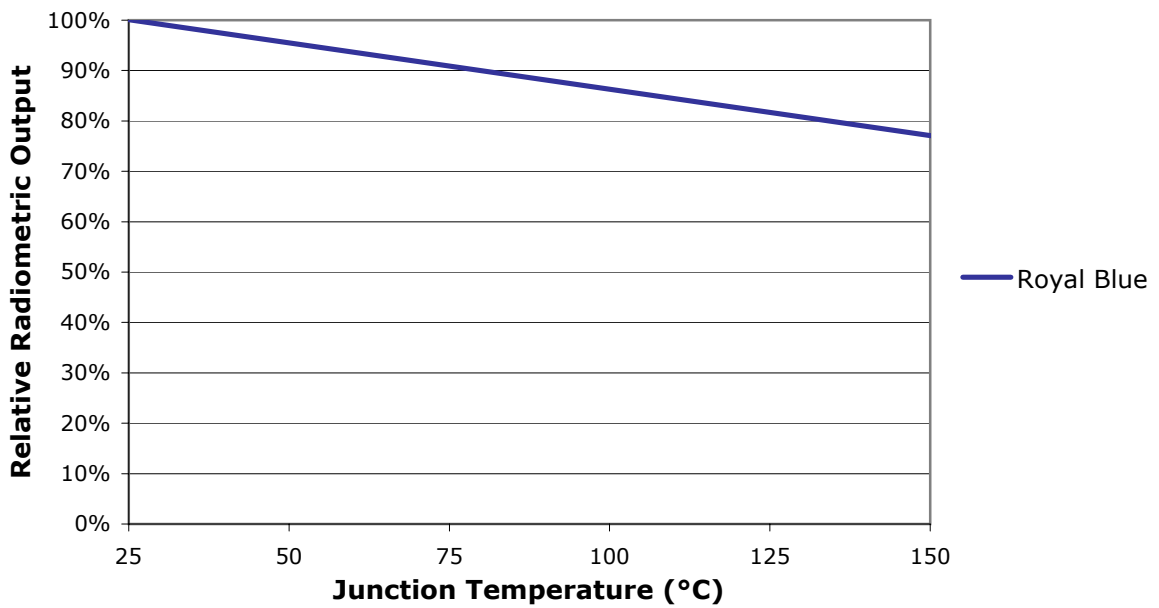
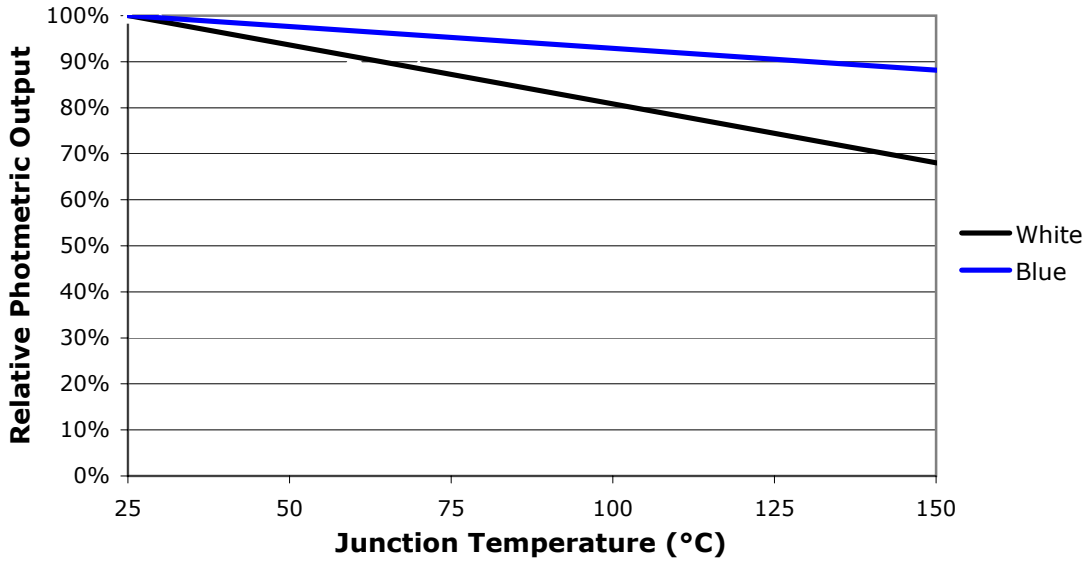

**Electrical Characteristics ( $T_j = 25^\circ\text{C}$ )**

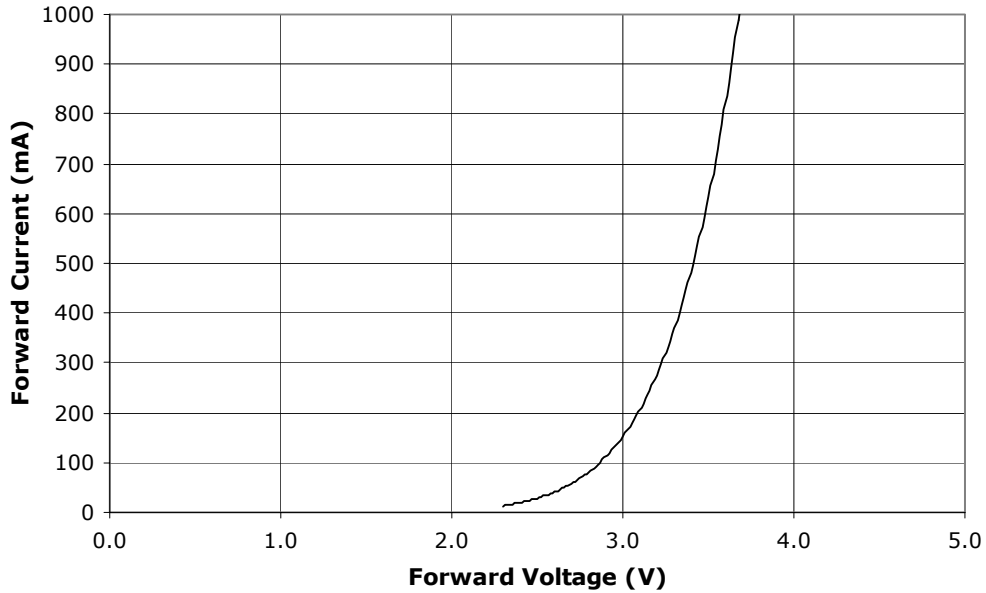

**Thermal Design**

The maximum forward current is determined by the thermal resistance between the LED junction and ambient. Given an existing thermal resistance of  $8^\circ\text{C/W}$  between the junction and the solder point, it is crucial for the end product to be designed in a manner that minimizes the thermal resistance from the solder point to ambient in order to optimize lamp life and optical characteristics.

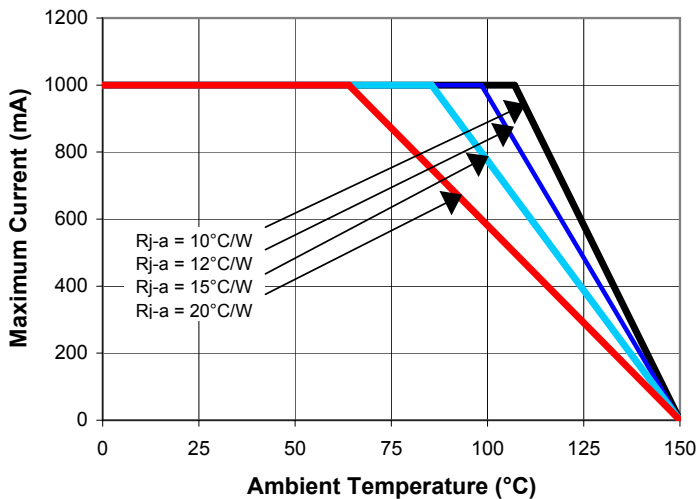

**Cool White**

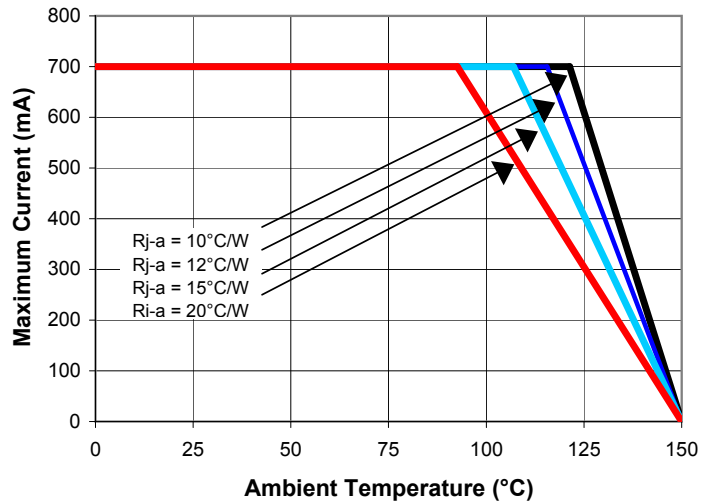

**Neutral White, Warm White, Blue and Royal Blue**

**Relative Intensity vs. Current ( $T_j = 25^\circ\text{C}$ )**

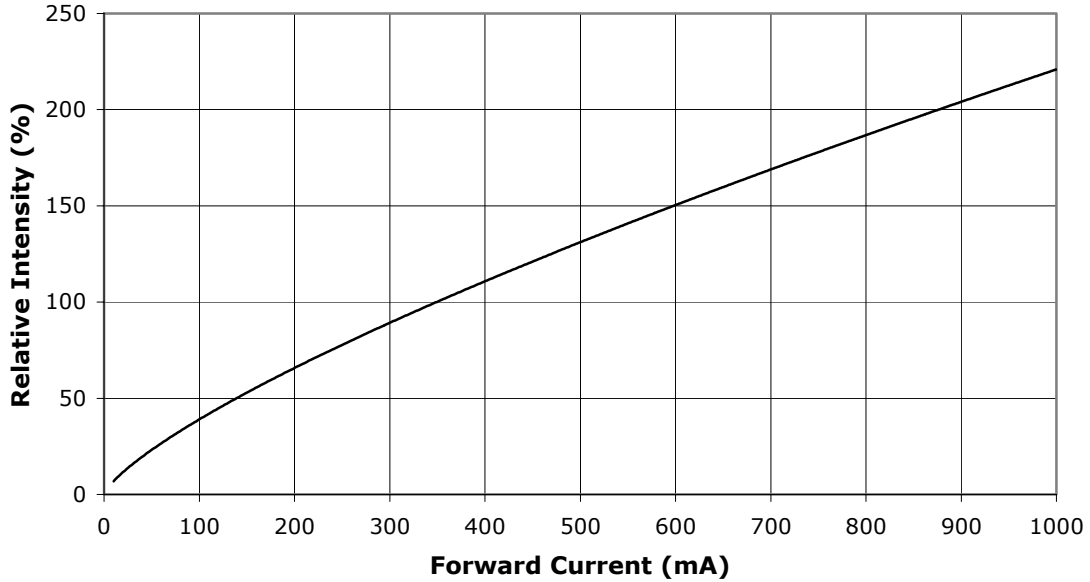

**Typical Spatial Radiation Pattern**

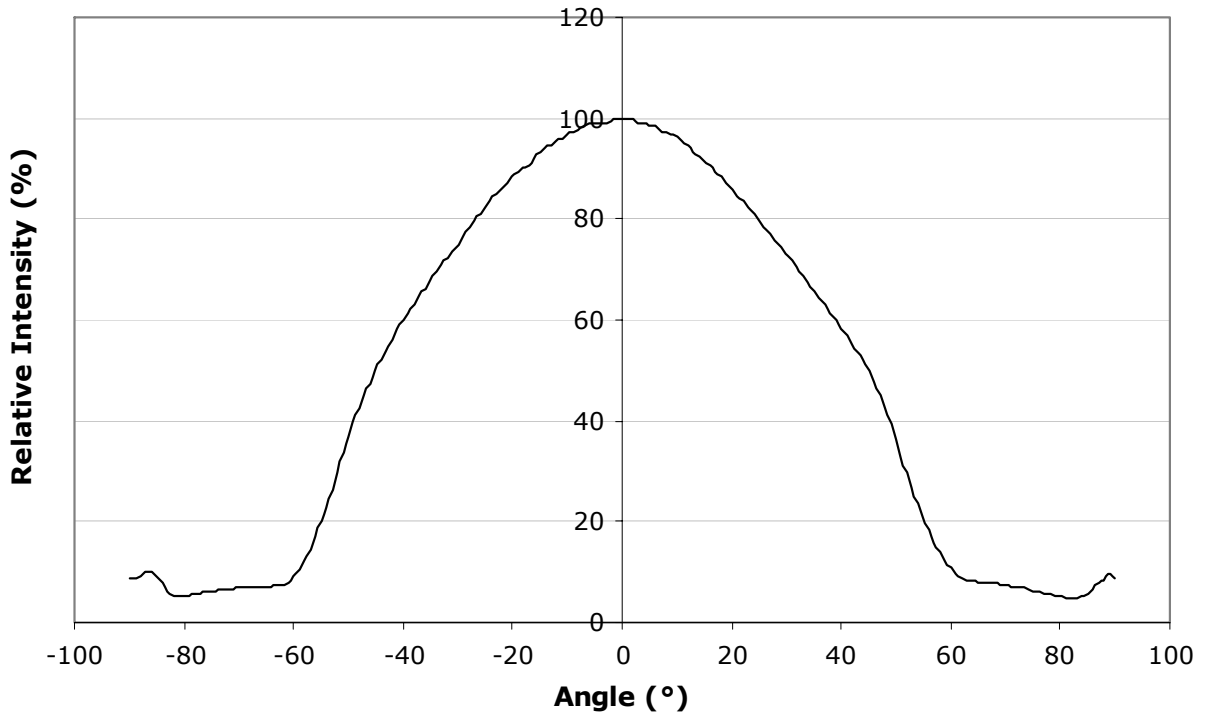

## Reflow Soldering Characteristics

The following reflow soldering profiles are provided for reference. Cree recommends that users follow the recommended soldering profile provided by the manufacturer of the solder paste used. Cree XLamp LEDs are compatible with JEDEC J-STD-020C.

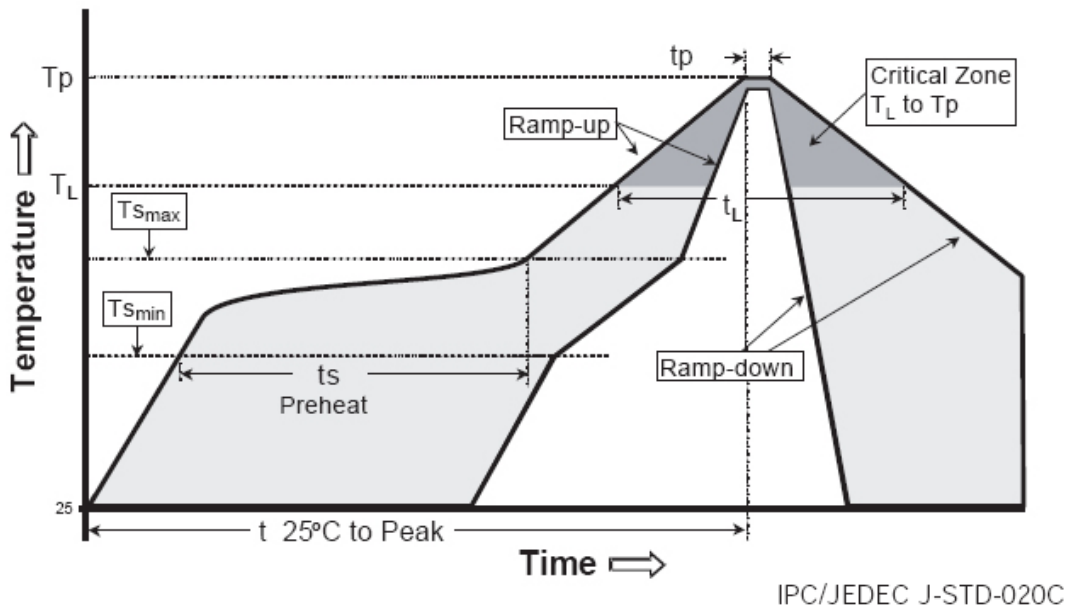

Profile Feature	Lead-Based Solder	Lead-Free Solder
Average Ramp-Up Rate ( $T_{s_{max}}$ to $T_p$ )	3°C/second max.	3°C/second max.
Preheat: Temperature Min ( $T_{s_{min}}$ )	100°C	150°C
Preheat: Temperature Max ( $T_{s_{max}}$ )	150°C	200°C
Preheat: Time ( $t_{s_{min}}$ to $t_{s_{max}}$ )	60-120 seconds	60-180 seconds
Time Maintained Above: Temperature ( $T_l$ )	183°C	217°C
Time Maintained Above: Time ( $t_l$ )	60-150 seconds	60-150 seconds
Peak/Classification Temperature ( $T_p$ )	215°C	260°C
Time Within 5°C of Actual Peak Temperature ( $t_p$ )	10-30 seconds	20-40 seconds
Ramp-Down Rate	6°C/second max.	6°C/second max
Time 25°C to Peak Temperature	6 minutes max.	8 minutes max.

Note: All temperatures refer to topside of the package, measured on the package body surface.



## Notes

### Lumen Maintenance Projections

Based on internal long-term reliability testing and standardized forecasting methods, Cree projects XLamp LEDs to maintain an average of 70% lumen maintenance after 50,000 hours, provided the LED junction temperature is maintained at or below 80°C.

Please read the XLamp Reliability application note for more details on Cree’s lumen maintenance testing and forecasting. Please read the XLamp Thermal Management application note for details on how thermal design, ambient temperature, and drive current affect the LED junction temperature.

### Moisture Sensitivity

XLamp LEDs are shipped in sealed, moisture-barrier bags (MBB) designed for long shelf life. If XLamp LEDs are exposed to moist environments after opening the MBB packaging but before soldering, damage to the LED may occur during the soldering operation. The following derating table defines the maximum exposure time (in days) for an XLamp LED in the listed humidity and temperature conditions. LEDs with exposure time longer than the time specified below must be baked according to the baking conditions listed below.

Temperature	Maximum Percent Relative Humidity						
	30%	40%	50%	60%	70%	80%	90%
30°C	9	5	4	3	1	1	1
25°C	12	7	5	4	2	1	1
20°C	17	9	7	6	2	2	1

### Baking Conditions

It is not necessary to bake all XLamp LEDs. Only the LEDs that meet all of the following criteria must be baked:

1. LEDs that have been removed from the original MBB packaging
2. LEDs that have been exposed to a humid environment longer than listed in the Moisture Sensitivity section above
3. LEDs that have not been soldered

LEDs should be baked at 80°C for 24 hours. LEDs may be baked on the original reels. Remove LEDs from MBB packaging before baking. Do not bake parts at temperatures higher than 80°C. This baking operation resets the exposure time as defined in the Moisture Sensitivity section above.

### Storage Conditions

XLamp LEDs that have been removed from original MBB packaging but not soldered yet should be stored in a room or cabinet that will maintain an atmosphere of 25 ± 5°C and no greater than 10% RH (relative humidity). For LEDs stored in these conditions, storage time does not add to exposure time as defined in the Moisture Sensitivity section above.

### RoHS Compliance

The levels of environmentally sensitive, persistent biologically toxic (PBT), persistent organic pollutants (POP), or otherwise restricted materials in this product are below the maximum concentration values (also referred to as the threshold limits) permitted for such substances, or are used in an exempted application, in accordance with EU Directive 2002/95/EC on the restriction of the use of certain hazardous substances in electrical and electronic equipment (RoHS), as amended through April 21, 2006.

### Vision Advisory Claim

Users should be cautioned not to stare at the light of this LED product. The bright light can damage the eye.

**Mechanical Dimensions (T<sub>A</sub> = 25°C)**

All measurements are ±.1mm unless otherwise indicated.

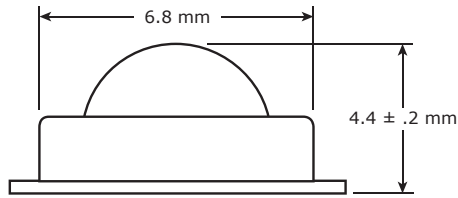
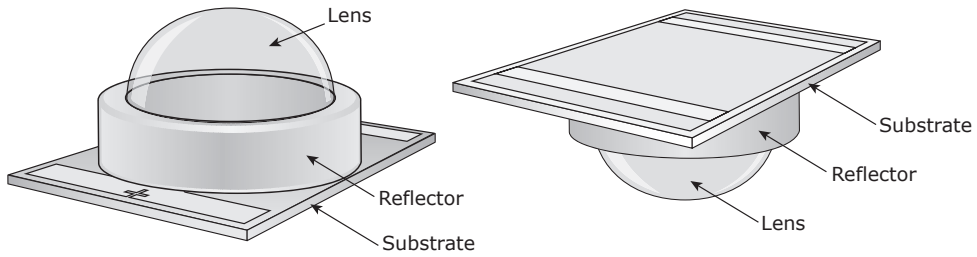

Side View

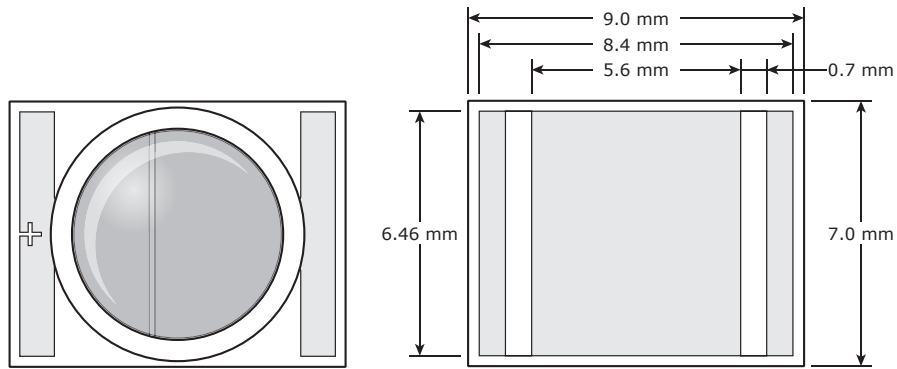

Top View

Bottom View

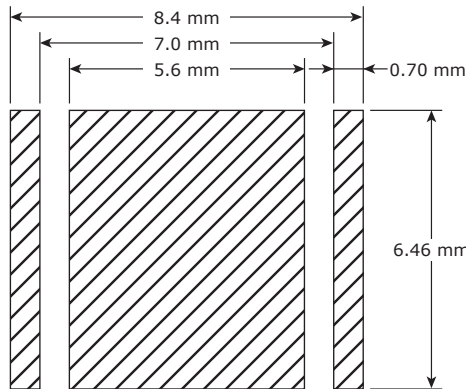

Recommended PC Board Solder Pad

**Tape and Reel**

All dimensions in mm.

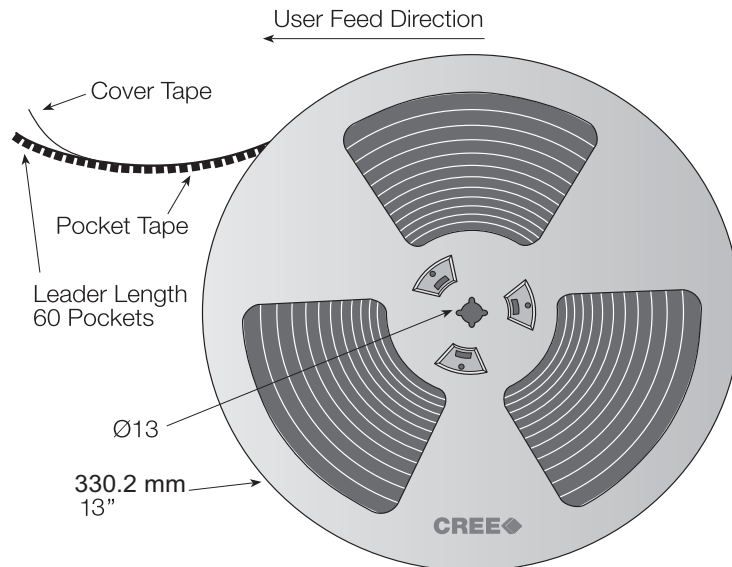
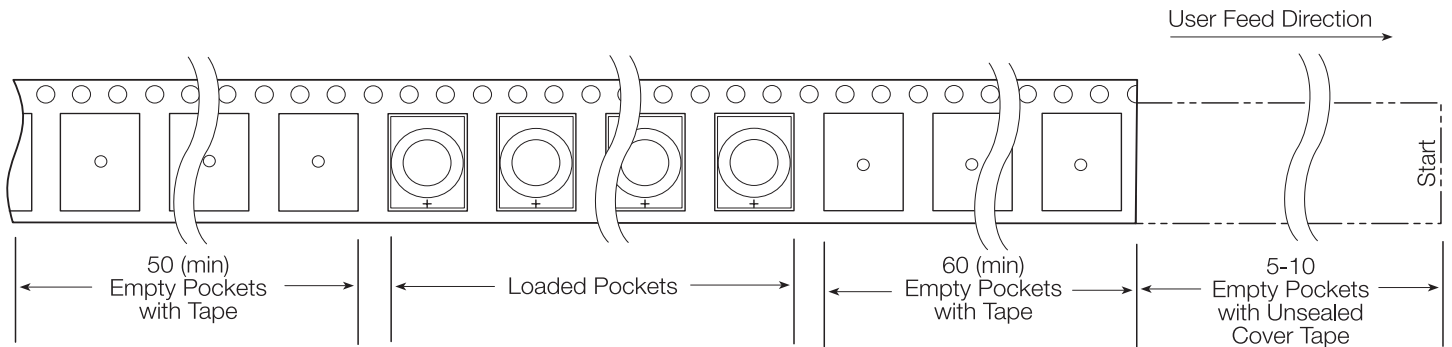
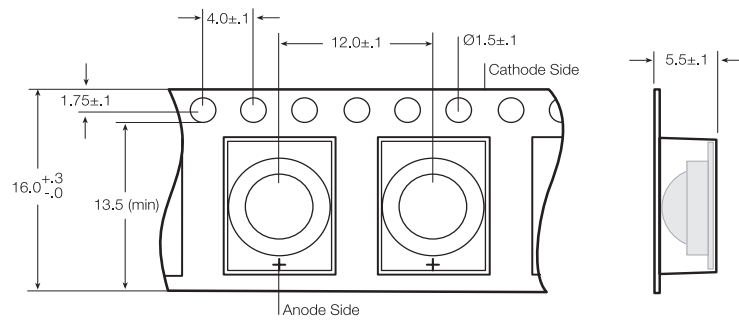
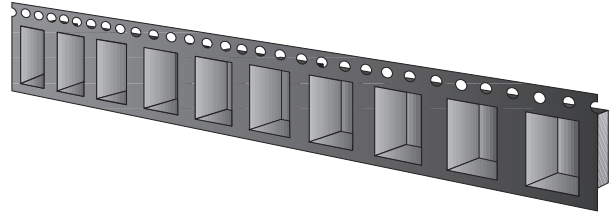
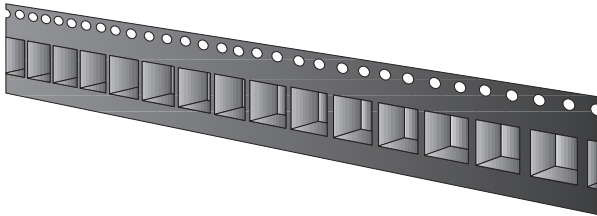

**Dry Packaging and Packaging**

