

### 1.5V STEREO HEADPHONE AMPLIFIER

The KIA8159FN is developed for play-back stereo headphone equipments (1.5V use). It is built in dual auto-reverse pre amplifiers, dual OCL power amplifiers, and a ripple filter.

#### FEATURES

##### Power Amp. Stage

- OCL (Output Condenser Less)
- Low Noise :  $V_{no}=48\mu V_{rms}$ (Typ.)
- Output Power :  $PO=6mW$ (Typ.)  
(at  $V_{CC}=1.5V$ ,  $f=1kHz$ ,  $THD=10\%$ )
- Excellent ripple rejection ratio :  $RR=54dB$ (Typ.)
- Voltage Gain :  $G_V=28dB$ (Typ.)
- Built-in power amplifier mute.

##### Pre-Amp. Stage

- Auto-reverse with F/R control switch
- Low Noise :  $V_{no}=1.7\mu V_{rms}$ (Typ.)
- Input coupling condenser-less
- Built-in input capacitor for reducing buzz noise
- Built-in pre-amplifier mute

##### TOTAL

- Built-in ripple filter
- Built-in over switch
- Operating supply voltage range :  $V_{CC(oper)}=0.9V \sim 2.2V$ (Typ.)

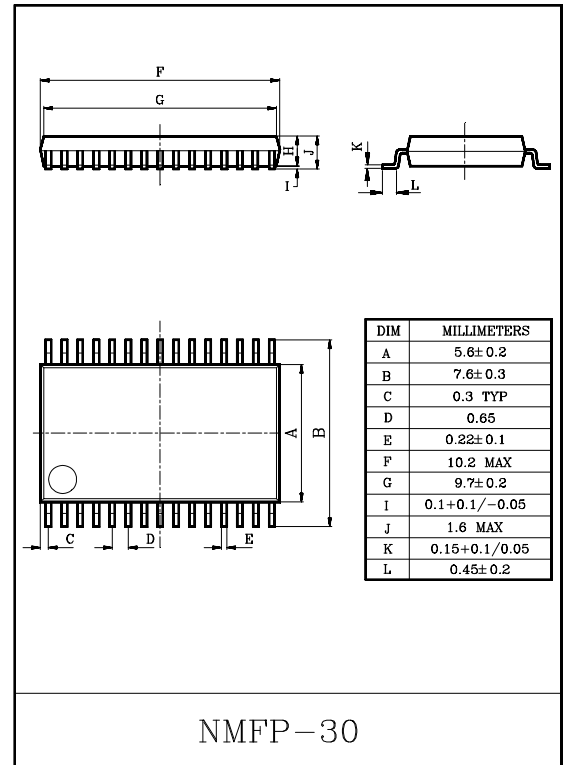

#### MAXIMUM RATINGS (Ta=25°C)

CHARACTERISTIC		SYMBOL	RATING	UNIT
Supply Voltage		$V_{CC}$	3	V
Output Current	Power	$I_{O(peak)}$	60	mA
	Ripple Filter	$I_{RF}$	5	
Power Dissipation		$P_D$ (Note)	550	mW
Operating Temperature		$T_{opr}$	-25~75	°C
Storage Temperature		$T_{stg}$	-55~150	°C

Note) Derated above  $T_a=25^\circ C$  in the proportion of  $4.4mW/^\circ C$  for KIA8159FN.

# KIA8159FN

## BLOCK DIAGRAM

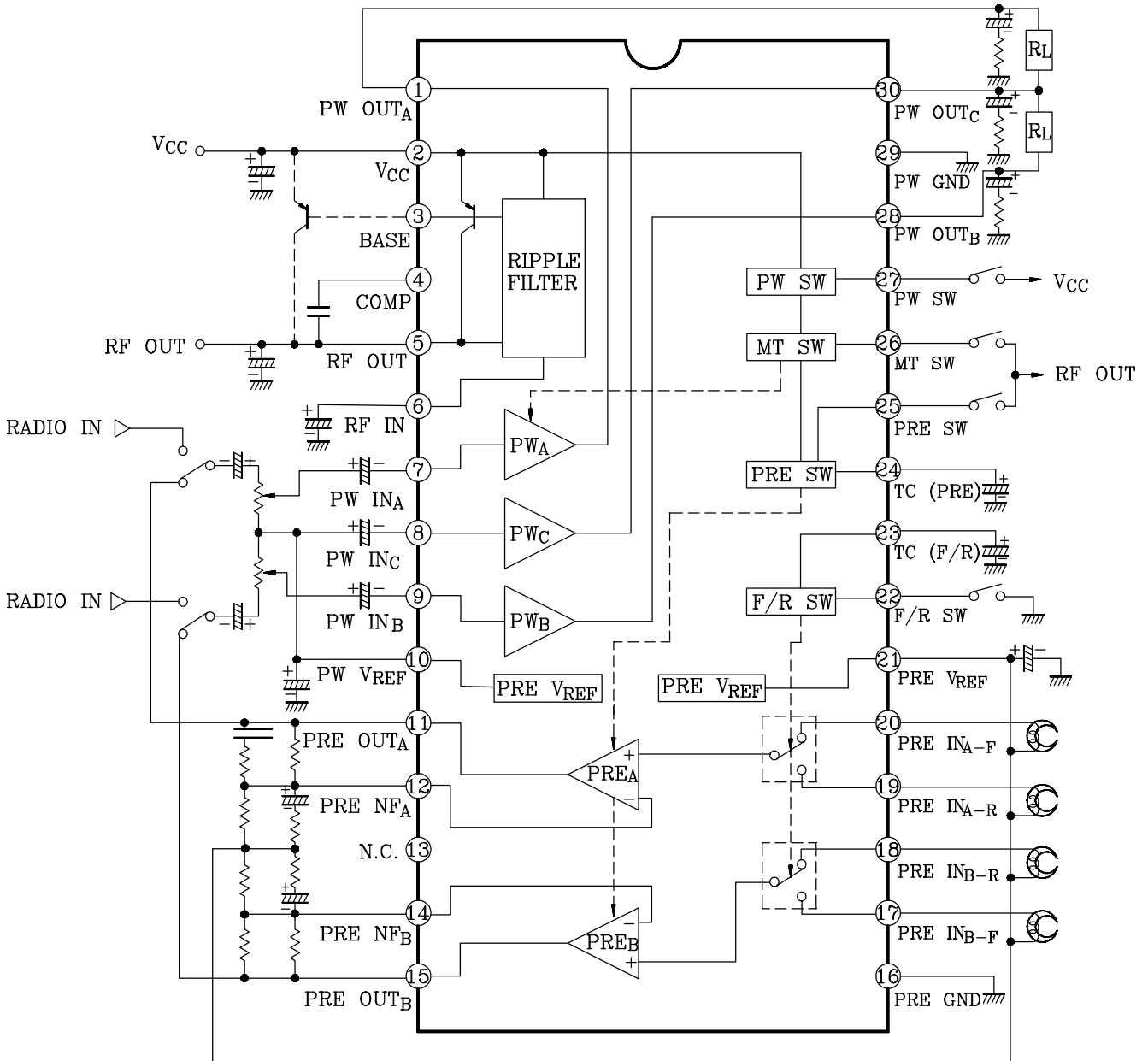

# KIA8159FN

## ELECTRICAL CHARACTERISTICS

(Unless otherwise specified,  $V_{CC}=1.2V$ ,  $f=1kHz$ ,  $T_a=25^{\circ}C$   $SW_1 : a$ ,  $SW_2 : a$ ,  $SW_3 : a$ ,  $SW_7 : on$ ,  
 Power-amplifier stage :  $R_g=600\Omega$ ,  $R_L=16\Omega$ ,  $SW_3 : b$ ,  $SW_6 : a$ ,  
 Power-amplifierstage :  $R_g=2.2k\Omega$ ,  $R_L=10k\Omega$ ,  $SW_2 : b$ ,  $SW_5 : a$ ,

CHARACTERISTIC		SYMBOL	TEST CIRCUIT	TEST CONDITION	MIN.	TYP.	MAX.	UNIT
Quiescent Current		$I_{CCQ1}$	1	POWER OFF, $SW_1:b$ , $SW_2:b$	-	0.1	5	$\mu A$
		$I_{CCQ2}$		POWER Amp. OFF, $SW_2:b$	-	2.8	4.5	mA
		$I_{CCQ3}$		$V_{IN}=0$	-	13	16	
Power-amplifier Stage	Voltage Gain	$G_V$	2	$V_O=-22dBV$	26	28	30	dB
	Channel Balance	CB			-	0	1.5	
	Output Power	$P_O$		$V_{CC}=1.5V$ , $V_{IN(A)}=V_{IN(B)}$ THD=10%	5	6	-	mW
	Total Harmonic Distortion	THD <sub>1</sub>		$V_{CC}=1V$ , $P_O(A)=P_O(B)=1mW$	-	0.4	1.5	%
	Output Noise Voltage	$V_{NO}$		BPF:20Hz~20kHz, $SW_6:b$	-	48	70	$\mu V_{rms}$
	Ripple Rejection Ratio	RR <sub>1</sub>		$V_{CC}=1V$ , $f_r=100Hz$ , $V_r=-32dBV$ $I_{RF}=0$ , $SW_6:b$ , $SW_7:open$	45	54	-	dB
	Cross Talk (CH-A/CH-B)	CT <sub>1</sub>		$V_O=-22dBV$	30	38	-	
	Power Muting Attenuation	ATT <sub>1</sub>		$V_O=-22dBV$ , $SW_2 : a \rightarrow b$	70	83	-	
Ripple Filter Stage	Output Voltage	$V_{RF}$	2	$V_{CC}=1V$ , $I_{RF}=0$	0.88	0.92	-	V
	Ripple Rejection Ratio	RR <sub>2</sub>		$V_{CC}=1V$ , $f_r=100Hz$ , $V_r=-32dBV$ $I_{RF}=30mA$ , $SW_7:open$	38	45	-	dB
Play Amp.	Open Loop Voltage Gain	$G_{VO}$	2	$V_O=-22dBm$ , $SW_5:b$	63	70	-	dB
	Closed Loop Voltage Gain	$G_{VC}$		$V_O=-22dBm$	-	34	-	
	Maximum Output Voltage	$V_{OM}$		THD=1%	160	290	-	$mV_{rms}$
	Total Harmonic Distortion	THD <sub>2</sub>		$V_{CC}=1V$ , $V_O=100mV_{rms}$	-	0.06	0.3	%
	Equivalent Input Noise Voltage	$V_{NI}$		BPF:20Hz~20kHz $SW_8:open$ NAB ( $f=1kHz$ , $G_V=34dB$ )	-	1.7	2.7	$\mu V_{rms}$
	Cross Talk (CH-A/CH-B)	CT <sub>2</sub>		$V_O=-22dBm$	-	61	-	dB
	Cross Talk (Forward/Reverse)	CT <sub>3</sub>			-	61	-	
	Pre Muting Attenuation	ATT <sub>2</sub>			$V_O=-22dBV$ , $SW_3:a \rightarrow b$	-	75	
Power ON Current	$I_{27}$	1	$V_{CC}=0.9V$	$V_{10} \geq 0.5V$ , $SW_1:c$	5	-	-	$\mu A$
Power OFF Voltage	$V_{27}$			$V_{10} \leq 0.3V$ , $SW_1:d$	0	-	0.3	V
Power Amp. Mute OFF Current	$I_{26}$			$V_{30} \geq 0.4V$ , $SW_2:c$	5	-	-	$\mu A$
Power Amp. Mute ON Current	$V_{26}$			$V_{30} \leq 0.3V$ , $SW_2:d$	0	-	0.3	V
Pre Amp. ON Current	$I_{25}$			$V_{24} \geq 0.5V$ , $SW_3:c$	5	-	-	$\mu A$
Pre Amp. OFF Voltage	$V_{25}$			$V_{24} \leq 0.3V$ , $SW_3:d$	0	-	0.3	V
Reverse Mode Voltage	$V_{22}$			$V_{23} \geq 0.5V$ , $SW_4:c$	0	-	0.3	V

# KIA8159FN

## EXPLANATION OF TERMINALS

(Terminal Voltage : Typical terminal voltage at no signal with test circuit  $V_{CC}=1.2V$ ,  $T_a=25^\circ C$ )

PIN NO.	TERMINAL NAME	FUNCTION	INTERNAL CIRCUIT	TERMINAL VOLTAGE(V)	
1	PW OUT <sub>A</sub>	Output of power amplifier.		0.6	
28	PW OUT <sub>B</sub>			0.6	
30	PW OUT <sub>C</sub>	Output of common power amplifier.		0.6	
7	PW IN <sub>A</sub>	Input of power amplifier.		0.75	
9	PW IN <sub>B</sub>			0.75	
8	PW IN <sub>C</sub>	Input of common power Amplifier.		0.75	
2	V <sub>CC</sub>	-			1.2
3	BASE	Base bias of an external PNP transistor for ripple filter.			0.5
4	COMP	Phase compensation of ripple filter circuit.	0.5		
5	RF OUT	Ripple filter output. Ripple filter circuit supplies V <sub>REF</sub> circuit, Pre-amplifier circuit, and F/R switch circuit with power source.	1.13		
6	RF IN	Ripple filter terminal.	1.13		
10	PW V <sub>REF</sub>	Reference voltage of power amplifier.		0.75	

# KIA8159FN

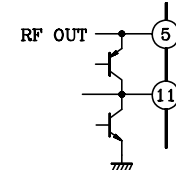
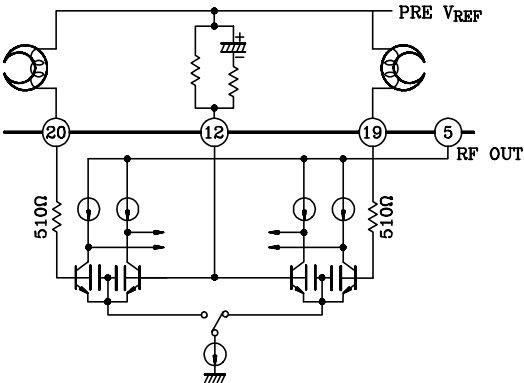
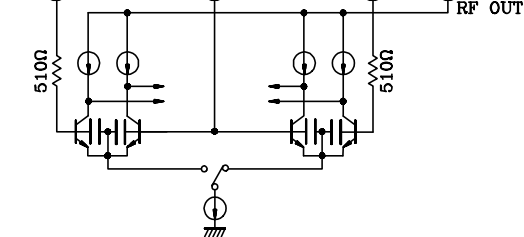
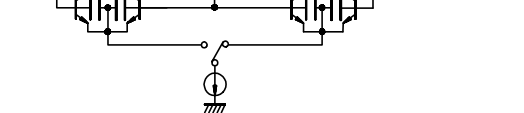
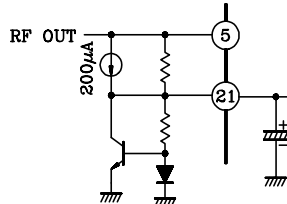
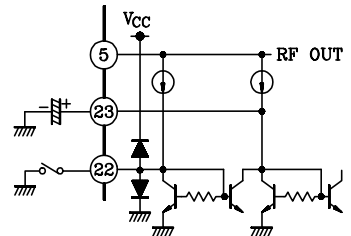
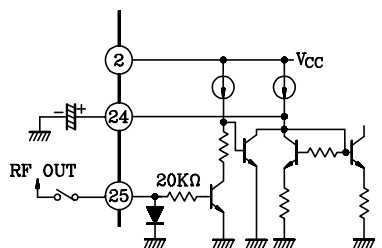
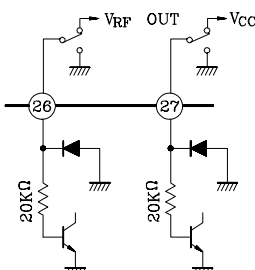
PIN NO.	TERMINAL NAME	FUNCTION	INTERNAL EQUIVALENT CIRCUIT	TERMINAL VOLTAGE(V)
11	PRE OUT <sub>A</sub>	Output of pre-amplifier.		0.5
15	PRE OUT <sub>B</sub>			
12	PRE NF <sub>A</sub>	NF of pre-amplifier.		0.75
14	PRE NF <sub>B</sub>			
17	PRE IN <sub>B-F</sub>	Forward input of pre-amplifier. (at F/R SW : open)		0.75
20	PRE IN <sub>A-F</sub>			
18	PRE IN <sub>B-R</sub>	Reverse input of pre-amplifier. (at F/R SW : GND)		0.75
19	PRE IN <sub>A-R</sub>			
13	NC	-	-	-
16	PRE GND	-	-	0
21	PRE V <sub>REF</sub>	Reference voltage of pre-amplifier.		0.75
22	F/R SW	Forward/Reverse mode switch. • OPEN : Forward mode. • GND : Reverse mode.		-
23	TC (F/R)	Smoothing terminal. In order to reduce a pop noise at F/R switching.		0.7
24	TC (PRE)	Smoothing terminal. In order to reduce a pop noise at Pre-amplifier ON/OFF switching.		0.7
25	PRE SW	Pre-amplifier ON/OFF switch. • RF OUT : ON • GND/OPEN : OFF		-
26	MT SW	Muting switch for power amplifier • RF OUT : MUTE OFF • GND/OPEN : MUTE ON		-
27	PW SW	Power ON/OFF switch. • VCC : ON • GND/OPEN : OFF		-
29	PW GND	-	-	0

# KIA8159FN

TEST CIRCUIT 1

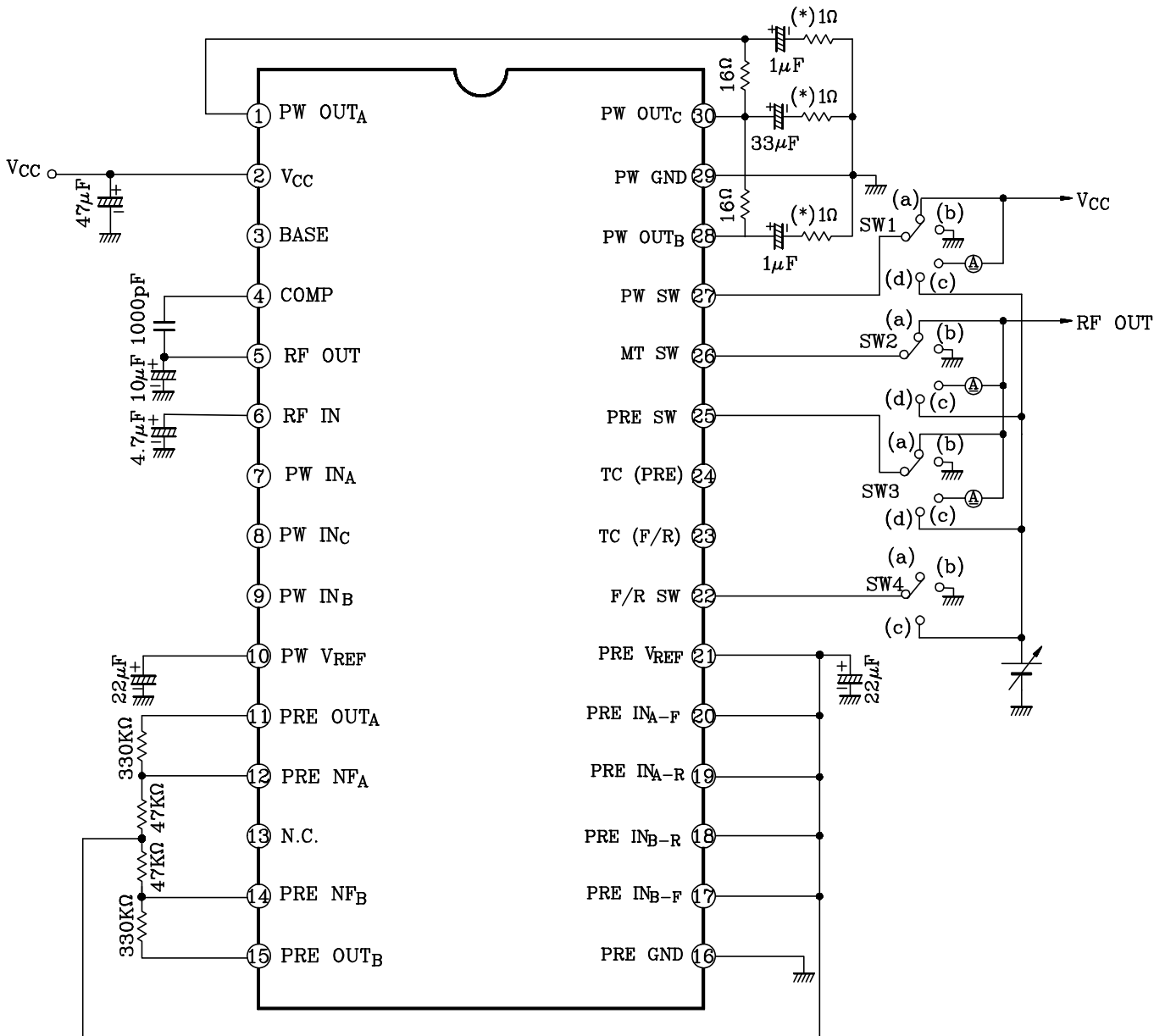

(\*) Tantal Condenser

# KIA8159FN

## TEST CIRCUIT 2

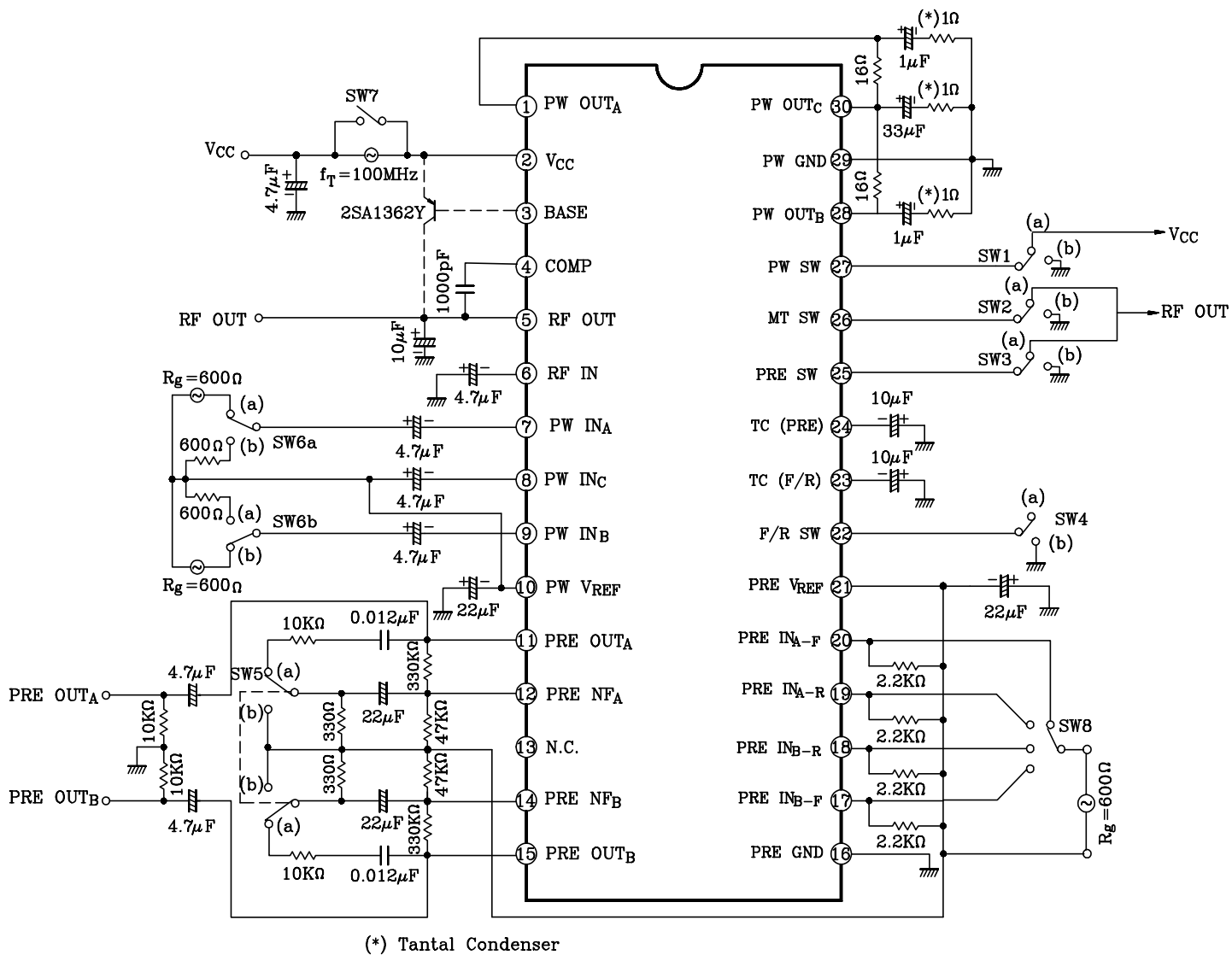

# KIA8159FN

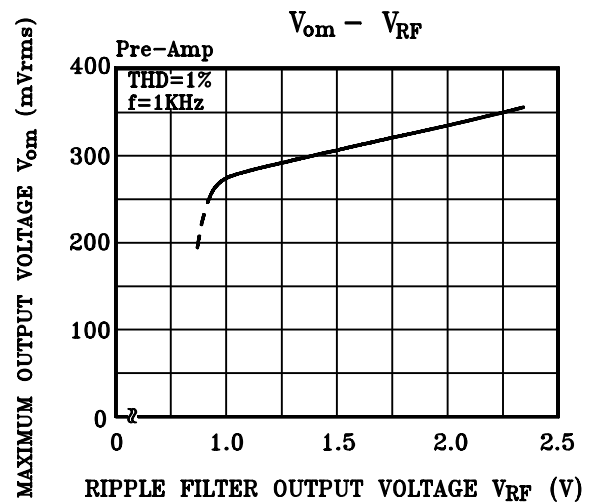
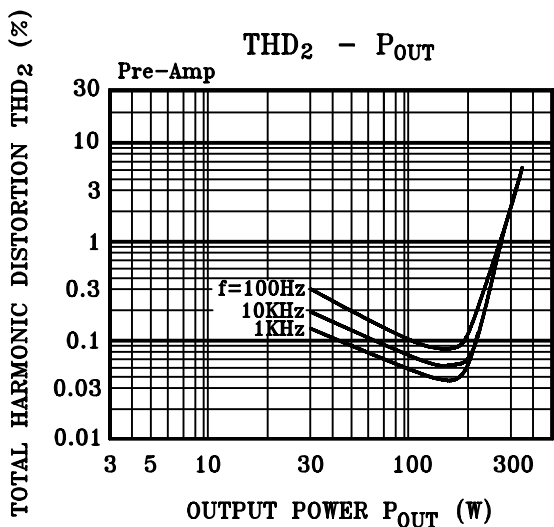
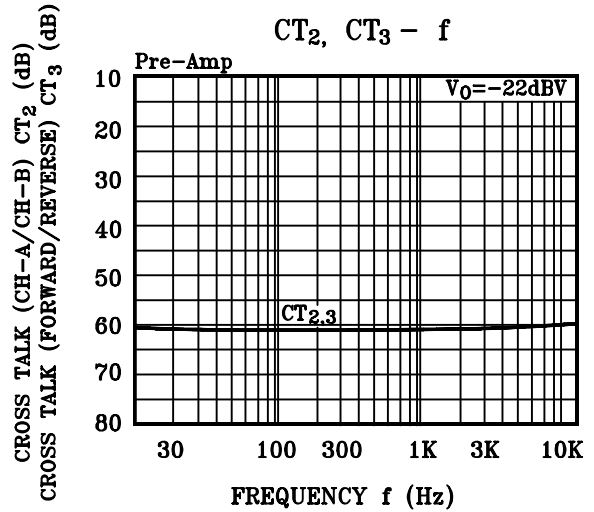
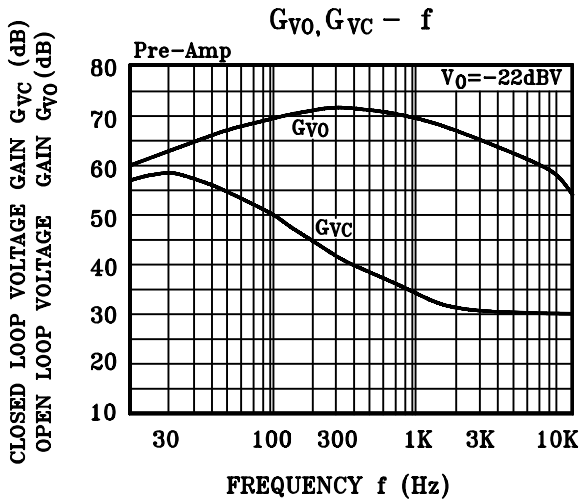
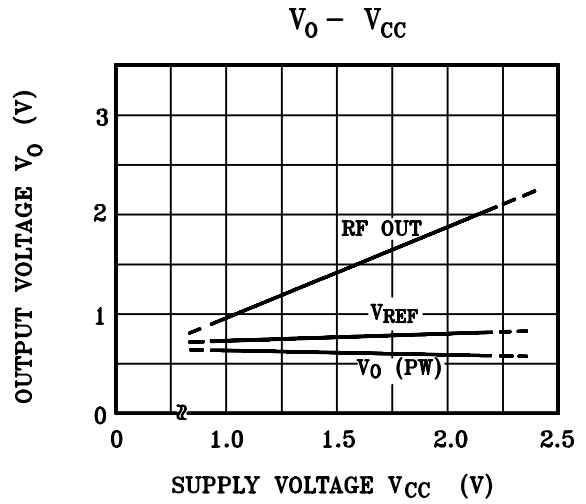
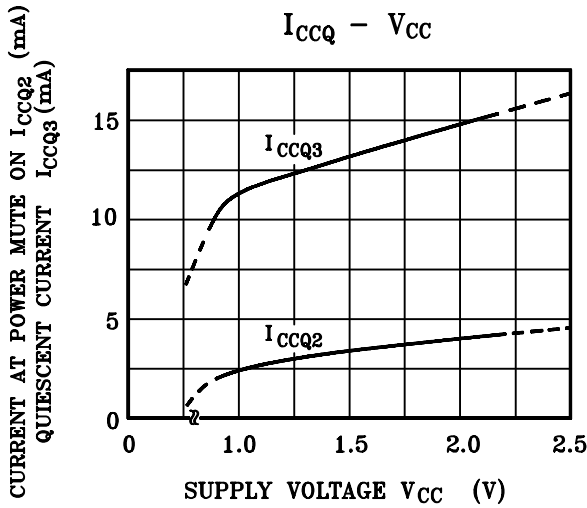



# KIA8159FN

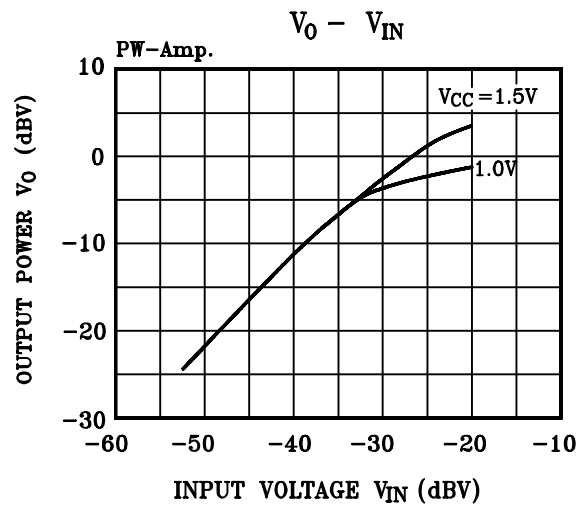
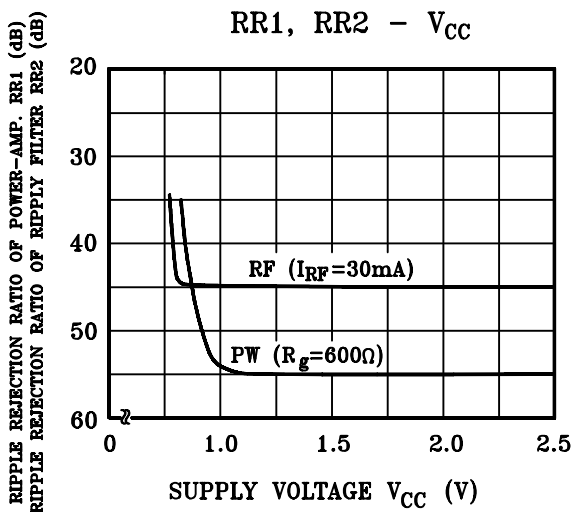
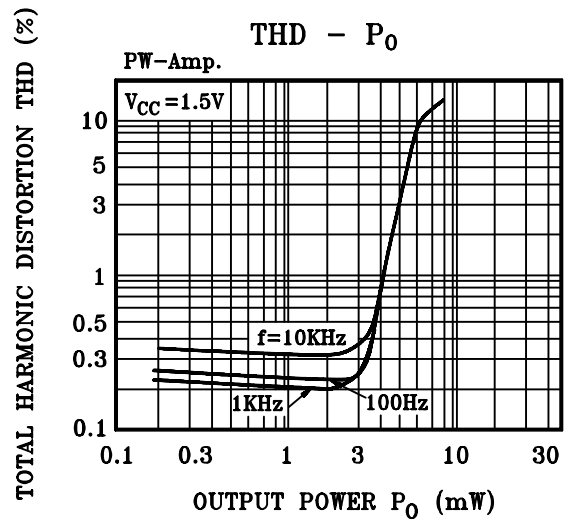
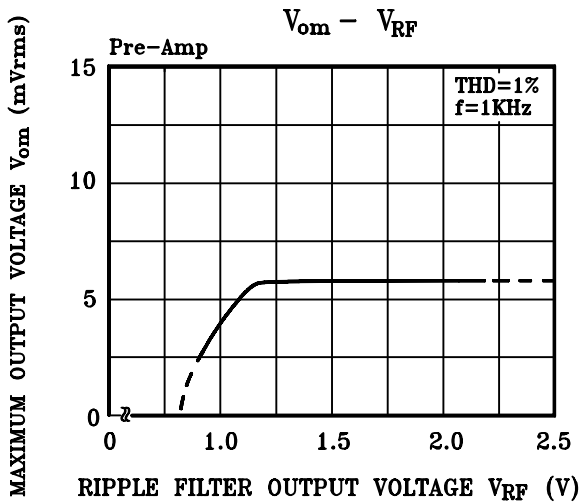
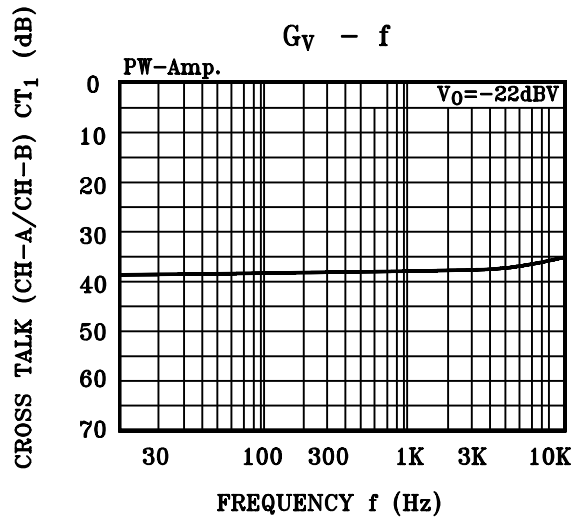
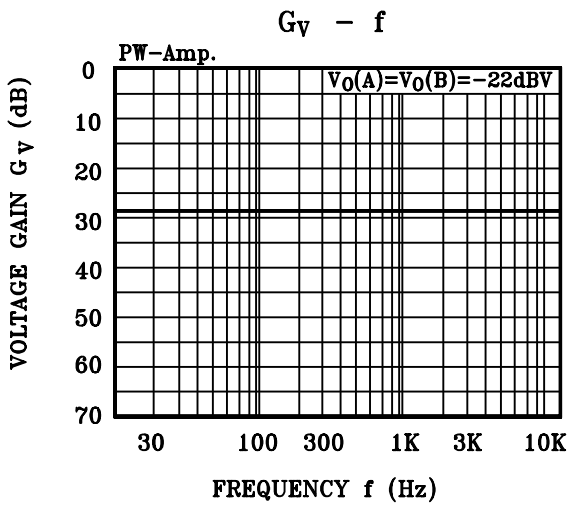

# KIA8159FN

