

64K (8K x 8) CMOS EEPROM

FEATURES

- Fast Read Access Time—150 ns
- CMOS Technology for Low Power Dissipation
 - 30 mA Active
 - 100 μ A Standby
- Fast Byte Write Time—200 μ s or 1 ms
- Data Retention >200 years
- High Endurance - Minimum 100,000 Erase/Write Cycles
- Automatic Write Operation
 - Internal Control Timer
 - Auto-Clear Before Write Operation
 - On-Chip Address and Data Latches
- Data Polling
- Ready/Busy
- Chip Clear Operation
- Enhanced Data Protection
 - VCC Detector
 - Pulse Filter
 - Write Inhibit
- Electronic Signature for Device Identification
- 5-Volt-Only Operation
- Organized 8Kx8 JEDEC Standard Pinout
 - 28-pin Dual-In-Line Package
 - 32-pin PLCC Package
 - 28-pin SOIC Package
- Available for Extended Temperature Ranges:
 - Commercial: 0°C to +70°C
 - Industrial: -40°C to +85°C

DESCRIPTION

The Microchip Technology Inc. 28C64A is a CMOS 64K non-volatile electrically Erasable PROM. The 28C64A is accessed like a static RAM for the read or write cycles without the need of external components. During a "byte write", the address and data are latched internally, freeing the microprocessor address and data bus for other operations. Following the initiation of write cycle, the device will go to a busy state and automatically clear and write the latched data using an internal control timer. To determine when the write cycle is complete, the user has a choice of monitoring the Ready/Busy output or using Data polling. The Ready/Busy pin is an open drain output, which allows easy configuration in wired-or systems. Alternatively, Data polling allows the user to read the location last written to when the write operation is complete. CMOS design and processing enables this part to be used in systems where reduced power consumption and reliability are required. A complete family of packages is offered to provide the utmost flexibility in applications.

PACKAGE TYPES

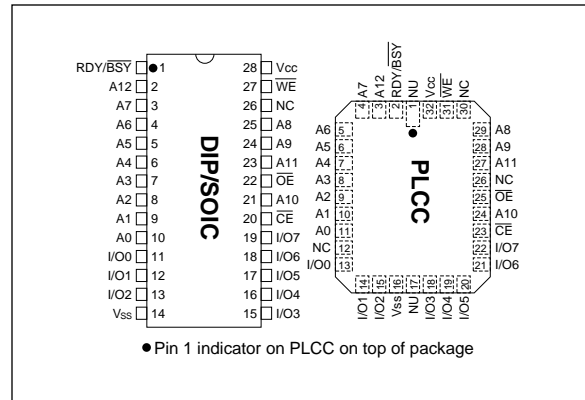

BLOCK DIAGRAM

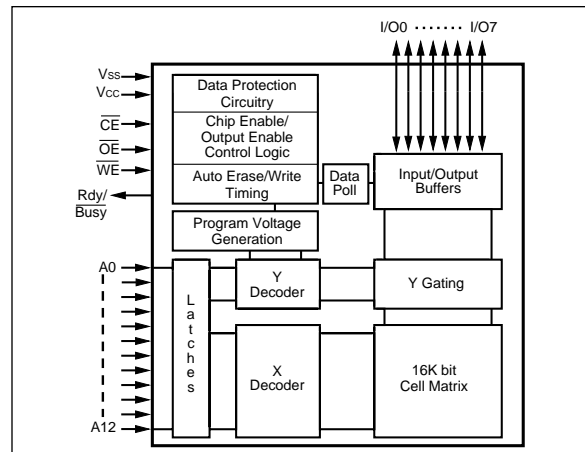

28C64A

1.0 ELECTRICAL CHARACTERISTICS

1.1 MAXIMUM RATINGS*

V_{CC} and input voltages w.r.t. V_{SS} -0.6V to + 6.25V
 Voltage on \overline{OE} w.r.t. V_{SS} -0.6V to +13.5V
 Voltage on A9 w.r.t. V_{SS} -0.6V to +13.5V
 Output Voltage w.r.t. V_{SS} -0.6V to V_{CC}+0.6V
 Storage temperature -65°C to +125°C
 Ambient temp. with power applied -50°C to +95°C

*Notice: Stresses above those listed under "Maximum Ratings" may cause permanent damage to the device. This is a stress rating only and functional operation of the device at those or any other conditions above those indicated in the operation listings of this specification is not implied. Exposure to maximum rating conditions for extended periods may affect device reliability.

TABLE 1-1: PIN FUNCTION TABLE

Name	Function
A0 - A12	Address Inputs
\overline{CE}	Chip Enable
\overline{OE}	Output Enable
\overline{WE}	Write Enable
I/O0 - I/O7	Data Inputs/Outputs
RDY/ \overline{Busy}	Ready/ \overline{Busy}
V _{CC}	+5V Power Supply
V _{SS}	Ground
NC	No Connect No Internal Connection
NU	Not Used No External Connection is Allowed

TABLE 1-2: READ/WRITE OPERATION DC CHARACTERISTIC

V _{CC} = +5V ±10% Commercial (C): Tamb = 0°C to +70°C Industrial (I): Tamb = -40°C to +85°C						
Parameter	Status	Symbol	Min	Max	Units	Conditions
Input Voltages	Logic '1' Logic '0'	V _{IH} V _{IL}	2.0 -0.1	V _{CC} +1 0.8	V V	
Input Leakage	—	I _{LI}	-10	10	μA	V _{IN} = -0.1V to V _{CC} +1
Input Capacitance	—	C _{IN}	—	10	pF	V _{IN} = 0V; Tamb = 25°C; f = 1 MHz (Note 2)
Output Voltages	Logic '1' Logic '0'	V _{OH} V _{OL}	2.4	0.45	V V	I _{OH} = -400 μA I _{OL} = 2.1 mA
Output Leakage	—	I _{LO}	-10	10	μA	V _{OUT} = -0.1V to V _{CC} +0.1V
Output Capacitance	—	C _{OUT}	—	12	pF	V _{IN} = 0V; Tamb = 25°C; f = 1 MHz (Note 2)
Power Supply Current, Active	TTL input	I _{CC}	—	30	mA	f = 5 MHz (Note 1) V _{CC} = 5.5V
Power Supply Current, Standby	TTL input TTL input CMOS input	I _{CC(S)TTL} I _{CC(S)TTL} I _{CC(S)CMOS}	—	2 3 100	mA mA μA	\overline{CE} = V _{IH} (0°C to +70°C) \overline{CE} = V _{IH} (-40°C to +85°C) \overline{CE} = V _{CC} -0.3 to V _{CC} +1 \overline{OE} = \overline{WE} = V _{CC} All other inputs equal V _{CC} or V _{SS}

Note 1: AC power supply current above 5MHz: 2mA/MHz.
 2: Not 100% tested.

TABLE 1-3: READ OPERATION AC CHARACTERISTICS

Parameter	Symbol	28C64A-15		28C64A-20		28C64A-25		Units	Conditions
		Min	Max	Min	Max	Min	Max		
		AC Testing Waveform: $V_{IH} = 2.4V$; $V_{IL} = 0.45V$; $V_{OH} = 2.0V$; $V_{OL} = 0.8V$ Output Load: 1 TTL Load + 100 pF Input Rise and Fall Times: 20 ns Ambient Temperature: Commercial (C): $T_{amb} = 0^{\circ}C$ to $+70^{\circ}C$ Industrial (I): $T_{amb} = -40^{\circ}C$ to $+85^{\circ}C$							
Address to Output Delay	t_{ACC}	—	150	—	200	—	250	ns	$\overline{OE} = \overline{CE} = V_{IL}$
\overline{CE} to Output Delay	t_{CE}	—	150	—	200	—	250	ns	$\overline{OE} = V_{IL}$
\overline{OE} to Output Delay	t_{OE}	—	70	—	80	—	100	ns	$\overline{CE} = V_{IL}$
\overline{CE} or \overline{OE} High to Output Float	t_{OFF}	0	50	0	55	0	70	ns	(Note 1)
Output Hold from Address, \overline{CE} or \overline{OE} , whichever occurs first.	t_{OH}	0	—	0	—	0	—	ns	(Note 1)
Endurance	—	1M	—	1M	—	1M	—	cycles	$25^{\circ}C$, $V_{CC} = 5.0V$, Block Mode (Note 2)

Note 1: Not 100% tested.

2: This parameter is not tested but guaranteed by characterization. For endurance estimates in a specific application, please consult the Total Endurance Model which can be obtained on our BBS or website.

FIGURE 1-1: READ WAVEFORMS

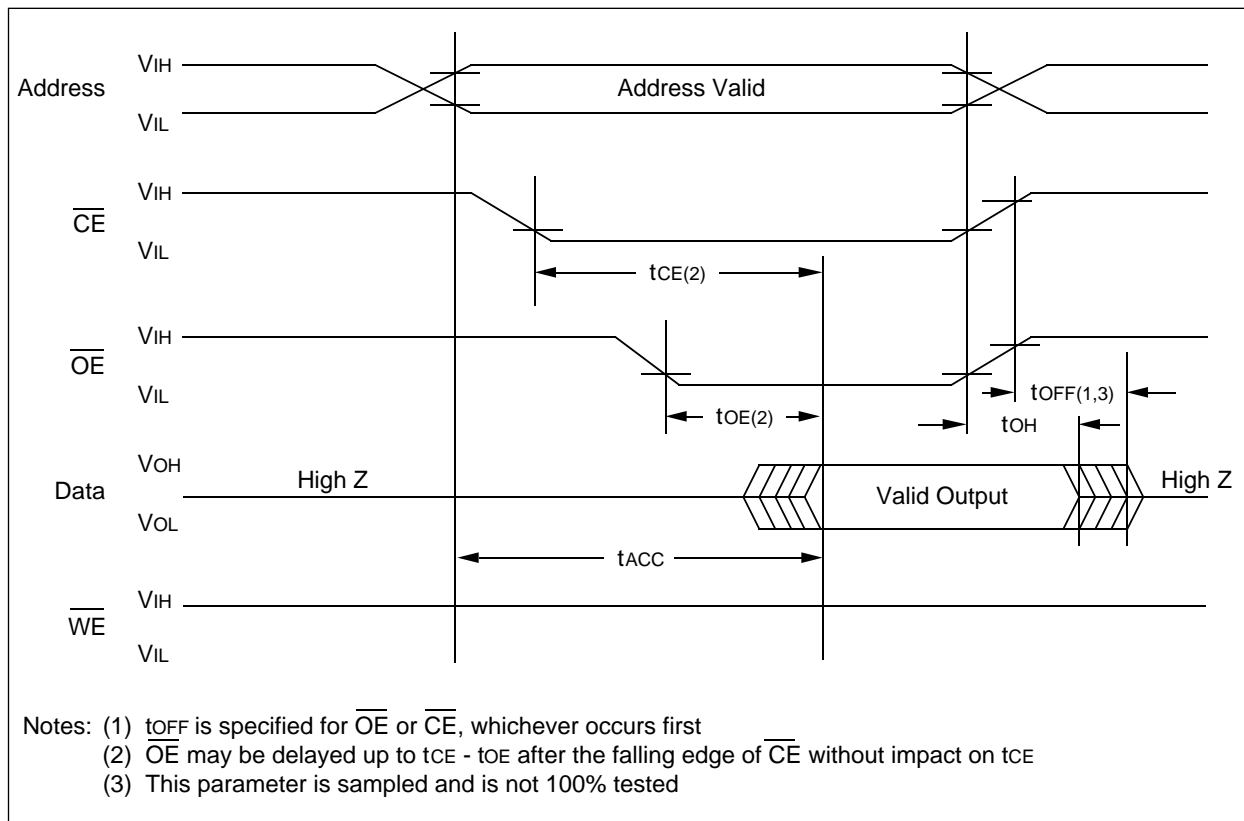

28C64A

TABLE 1-4: BYTE WRITE AC CHARACTERISTICS

Parameter	Symbol	Min	Max	Units	Remarks
AC Testing Waveform:		$V_{IH} = 2.4V$; $V_{IL} = 0.45V$; $V_{OH} = 2.0V$; $V_{OL} = 0.8V$ Output Load: 1 TTL Load + 100 pF Input Rise/Fall Times: 20 ns Ambient Temperature: Commercial (C): $T_{amb} = 0^{\circ}C$ to $+70^{\circ}C$ Industrial (I): $T_{amb} = -40^{\circ}C$ to $+85^{\circ}C$			
Address Set-Up Time	tAS	10	—	ns	
Address Hold Time	tAH	50	—	ns	
Data Set-Up Time	tDS	50	—	ns	
Data Hold Time	tDH	10	—	ns	
Write Pulse Width	twPL	100	—	ns	Note 1
Write Pulse High Time	twPH	50	—	ns	
\overline{OE} Hold Time	toEH	10	—	ns	
\overline{OE} Set-Up Time	toES	10	—	ns	
Data Valid Time	tDV	—	1000	ns	Note 2
Time to Device Busy	tDB	2	50	ns	
Write Cycle Time (28C64A)	twC	—	1	ms	0.5 ms typical
Write Cycle Time (28C64AF)	twC	—	200	μs	100 μs typical

- Note 1: A write cycle can be initiated by \overline{CE} or \overline{WE} going low, whichever occurs last. The data is latched on the positive edge \overline{WE} , whichever occurs first.
- 2: Data must be valid within 1000ns max. after a write cycle is initiated and must be stable at least until tDH after the positive edge of \overline{WE} or \overline{CE} , whichever occurs first.

FIGURE 1-2: PROGRAMMING WAVEFORMS

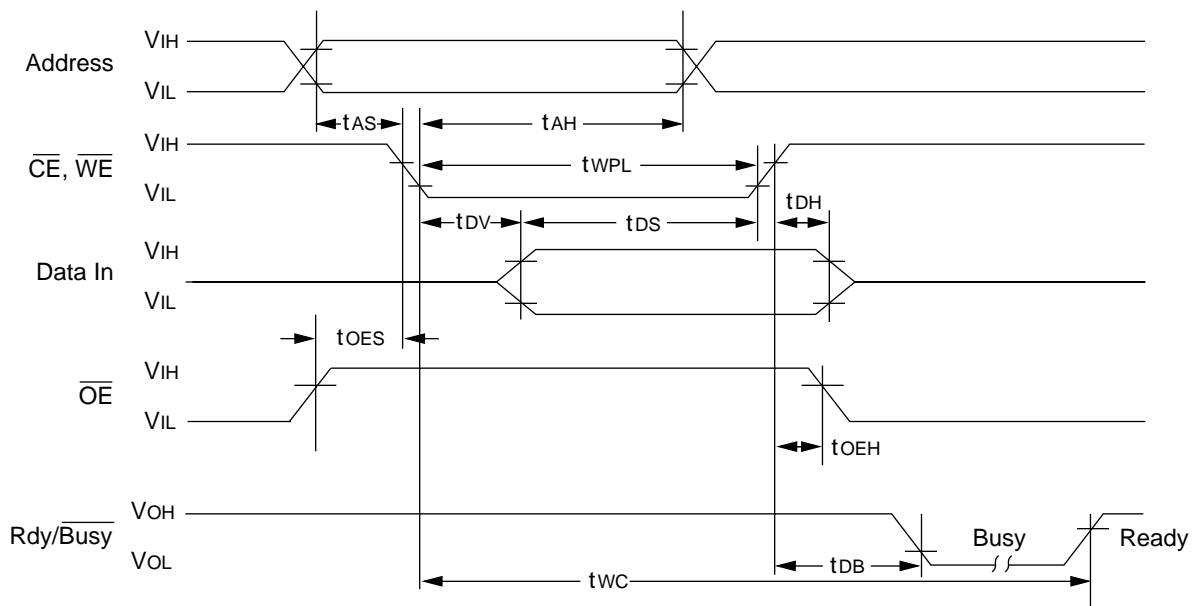

FIGURE 1-3: DATA POLLING WAVEFORMS

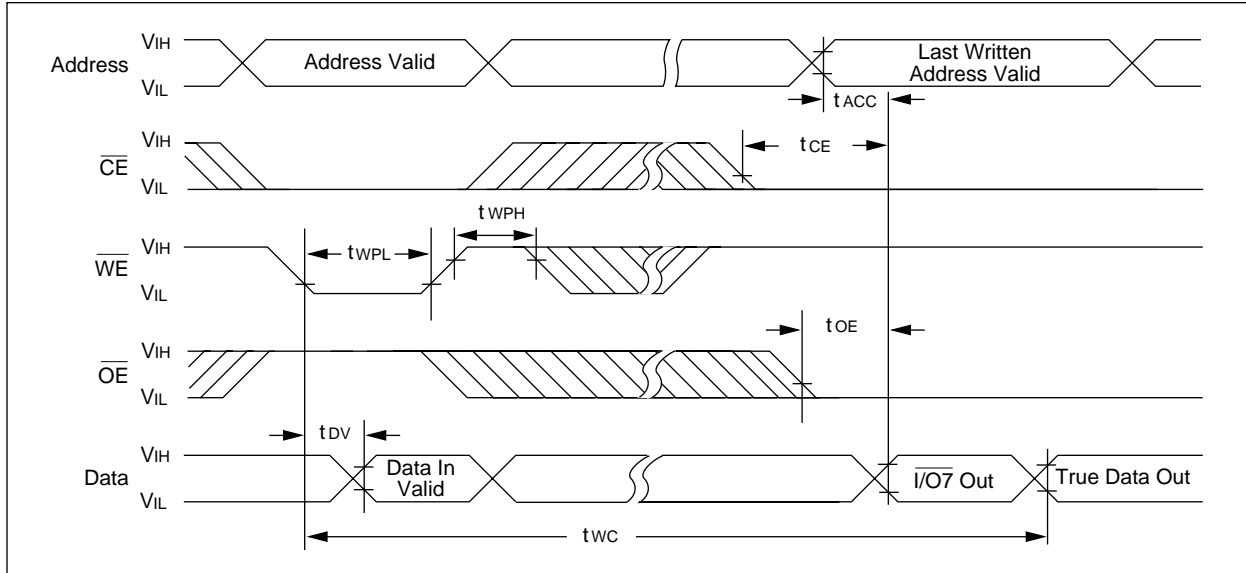

FIGURE 1-4: CHIP CLEAR WAVEFORMS

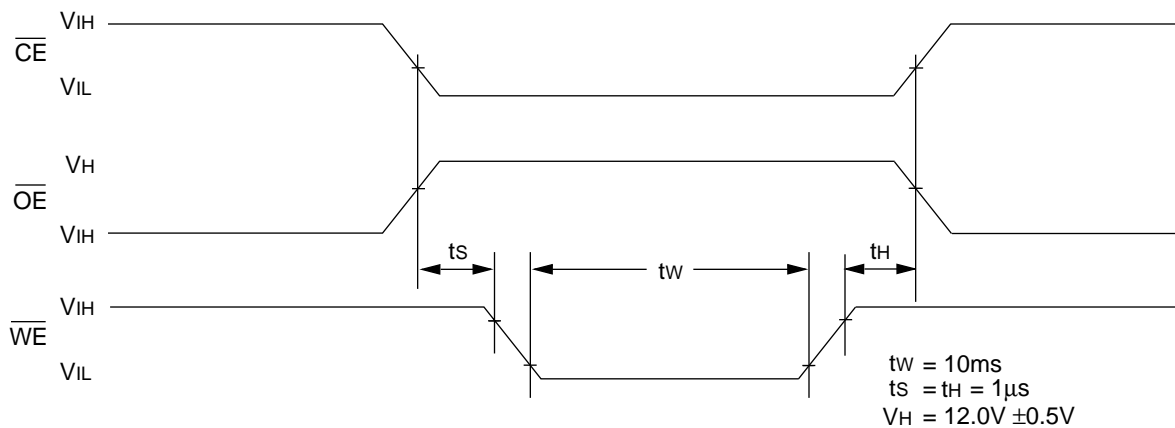

TABLE 1-5: SUPPLEMENTARY CONTROL

Mode	$\overline{\text{CE}}$	$\overline{\text{OE}}$	$\overline{\text{WE}}$	A9	Vcc	I/O
Chip Clear	V _{IL}	V _{IH}	V _{IL}	X	V _{CC}	
Extra Row Read	V _{IL}	V _{IL}	V _{IH}	A9 = V _H	V _{CC}	Data Out
Extra Row Write	*	V _{IH}	*	A9 = V _H	V _{CC}	Data In

Note: V_H = 12.0V ± 0.5V. *Pulsed per programming waveforms.

2.0 DEVICE OPERATION

The Microchip Technology Inc. 28C64A has four basic modes of operation—read, standby, write inhibit, and byte write—as outlined in the following table.

Operation Mode	\overline{CE}	\overline{OE}	\overline{WE}	I/O	Rdy/Busy (1)
Read	L	L	H	DOUT	H
Standby	H	X	X	High Z	H
Write Inhibit	H	X	X	High Z	H
Write Inhibit	X	L	X	High Z	H
Write Inhibit	X	X	H	High Z	H
Byte Write	L	H	L	DIN	L
Byte Clear	Automatic Before Each "Write"				

Note 1: Open drain output.

2: X = Any TTL level.

2.1 Read Mode

The 28C64A has two control functions, both of which must be logically satisfied in order to obtain data at the outputs. Chip enable (\overline{CE}) is the power control and should be used for device selection. Output Enable (\overline{OE}) is the output control and is used to gate data to the output pins independent of device selection. Assuming that addresses are stable, address access time (tACC) is equal to the delay from \overline{CE} to output (tCE). Data is available at the output tOE after the falling edge of \overline{OE} , assuming that \overline{CE} has been low and addresses have been stable for at least tACC-tOE.

2.2 Standby Mode

The 28C64A is placed in the standby mode by applying a high signal to the \overline{CE} input. When in the standby mode, the outputs are in a high impedance state, independent of the \overline{OE} input.

2.3 Data Protection

In order to ensure data integrity, especially during critical power-up and power-down transitions, the following enhanced data protection circuits are incorporated:

First, an internal VCC detect (3.3 volts typical) will inhibit the initiation of non-volatile programming operation when VCC is less than the VCC detect circuit trip.

Second, there is a \overline{WE} filtering circuit that prevents \overline{WE} pulses of less than 10 ns duration from initiating a write cycle.

Third, holding \overline{WE} or \overline{CE} high or \overline{OE} low, inhibits a write cycle during power-on and power-off (VCC).

2.4 Write Mode

The 28C64A has a write cycle similar to that of a Static RAM. The write cycle is completely self-timed and initiated by a low going pulse on the \overline{WE} pin. On the falling edge of \overline{WE} , the address information is latched. On rising edge, the data and the control pins (\overline{CE} and \overline{OE}) are latched. The Ready/Busy pin goes to a logic low level indicating that the 28C64A is in a write cycle which signals the microprocessor host that the system bus is free for other activity. When Ready/Busy goes back to a high, the 28C64A has completed writing and is ready to accept another cycle.

2.5 Data Polling

The 28C64A features \overline{Data} polling to signal the completion of a byte write cycle. During a write cycle, an attempted read of the last byte written results in the data complement of I/O7 (I/O0 to I/O6 are indeterminate). After completion of the write cycle, true data is available. \overline{Data} polling allows a simple read/compare operation to determine the status of the chip eliminating the need for external hardware.

2.6 Electronic Signature for Device Identification

An extra row of 32 bytes of EEPROM memory is available to the user for device identification. By raising A9 to 12V ±0.5V and using address locations 1FEO to 1FFF, the additional bytes can be written to or read from in the same manner as the regular memory array.

2.7 Chip Clear

All data may be cleared to 1's in a chip clear cycle by raising \overline{OE} to 12 volts and bringing the \overline{WE} and \overline{CE} low. This procedure clears all data, except for the extra row.

28C64A Product Identification System

To order or to obtain information, e.g., on pricing or delivery, please use the listed part numbers, and refer to the factory or the listed sales offices.

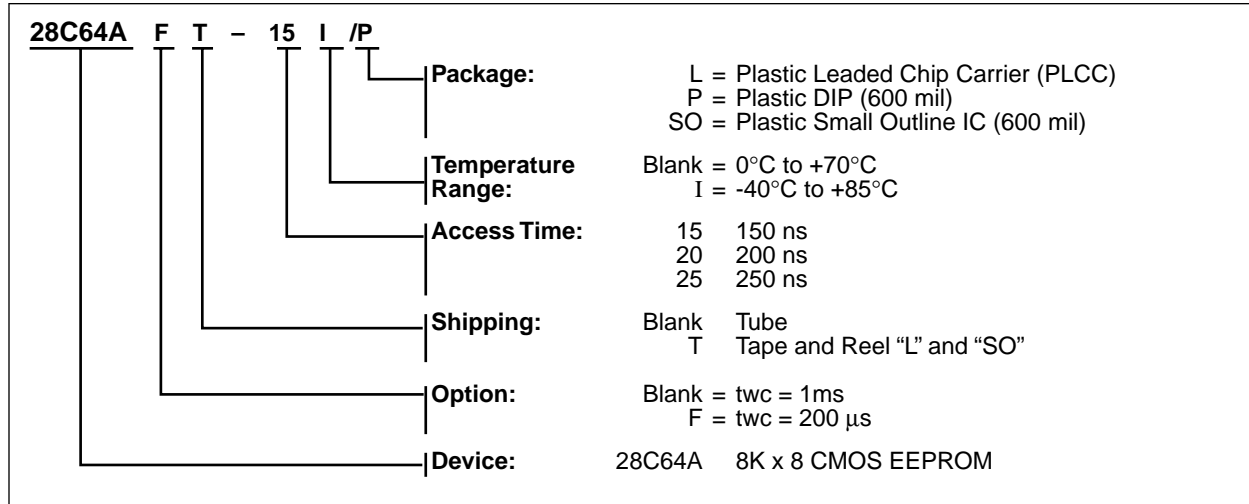

Note the following details of the code protection feature on PICmicro® MCUs.

- The PICmicro family meets the specifications contained in the Microchip Data Sheet.
- Microchip believes that its family of PICmicro microcontrollers is one of the most secure products of its kind on the market today, when used in the intended manner and under normal conditions.
- There are dishonest and possibly illegal methods used to breach the code protection feature. All of these methods, to our knowledge, require using the PICmicro microcontroller in a manner outside the operating specifications contained in the data sheet. The person doing so may be engaged in theft of intellectual property.
- Microchip is willing to work with the customer who is concerned about the integrity of their code.
- Neither Microchip nor any other semiconductor manufacturer can guarantee the security of their code. Code protection does not mean that we are guaranteeing the product as “unbreakable”.
- Code protection is constantly evolving. We at Microchip are committed to continuously improving the code protection features of our product.

If you have any further questions about this matter, please contact the local sales office nearest to you.

Information contained in this publication regarding device applications and the like is intended through suggestion only and may be superseded by updates. It is your responsibility to ensure that your application meets with your specifications. No representation or warranty is given and no liability is assumed by Microchip Technology Incorporated with respect to the accuracy or use of such information, or infringement of patents or other intellectual property rights arising from such use or otherwise. Use of Microchip's products as critical components in life support systems is not authorized except with express written approval by Microchip. No licenses are conveyed, implicitly or otherwise, under any intellectual property rights.

Trademarks

The Microchip name and logo, the Microchip logo, FilterLab, KEELOQ, microID, MPLAB, PIC, PICmicro, PICMASTER, PICSTART, PRO MATE, SEEVAL and The Embedded Control Solutions Company are registered trademarks of Microchip Technology Incorporated in the U.S.A. and other countries.

dsPIC, ECONOMONITOR, FanSense, FlexROM, fuzzyLAB, In-Circuit Serial Programming, ICSP, ICEPIC, microPort, Migratable Memory, MPASM, MPLIB, MPLINK, MPSIM, MXDEV, PICC, PICDEM, PICDEM.net, rfPIC, Select Mode and Total Endurance are trademarks of Microchip Technology Incorporated in the U.S.A.

Serialized Quick Turn Programming (SQTP) is a service mark of Microchip Technology Incorporated in the U.S.A.

All other trademarks mentioned herein are property of their respective companies.

© 2002, Microchip Technology Incorporated, Printed in the U.S.A., All Rights Reserved.

 Printed on recycled paper.



Microchip received QS-9000 quality system certification for its worldwide headquarters, design and wafer fabrication facilities in Chandler and Tempe, Arizona in July 1999. The Company's quality system processes and procedures are QS-9000 compliant for its PICmicro® 8-bit MCUs, KEELOQ® code hopping devices, Serial EEPROMs and microperipheral products. In addition, Microchip's quality system for the design and manufacture of development systems is ISO 9001 certified.



MICROCHIP

WORLDWIDE SALES AND SERVICE

AMERICAS

Corporate Office

2355 West Chandler Blvd.
Chandler, AZ 85224-6199
Tel: 480-792-7200 Fax: 480-792-7277
Technical Support: 480-792-7627
Web Address: <http://www.microchip.com>

Rocky Mountain

2355 West Chandler Blvd.
Chandler, AZ 85224-6199
Tel: 480-792-7966 Fax: 480-792-7456

Atlanta

500 Sugar Mill Road, Suite 200B
Atlanta, GA 30350
Tel: 770-640-0034 Fax: 770-640-0307

Boston

2 Lan Drive, Suite 120
Westford, MA 01886
Tel: 978-692-3848 Fax: 978-692-3821

Chicago

333 Pierce Road, Suite 180
Itasca, IL 60143
Tel: 630-285-0071 Fax: 630-285-0075

Dallas

4570 Westgrove Drive, Suite 160
Addison, TX 75001
Tel: 972-818-7423 Fax: 972-818-2924

Detroit

Tri-Atria Office Building
32255 Northwestern Highway, Suite 190
Farmington Hills, MI 48334
Tel: 248-538-2250 Fax: 248-538-2260

Kokomo

2767 S. Albright Road
Kokomo, Indiana 46902
Tel: 765-864-8360 Fax: 765-864-8387

Los Angeles

18201 Von Karman, Suite 1090
Irvine, CA 92612
Tel: 949-263-1888 Fax: 949-263-1338

New York

150 Motor Parkway, Suite 202
Hauppauge, NY 11788
Tel: 631-273-5305 Fax: 631-273-5335

San Jose

Microchip Technology Inc.
2107 North First Street, Suite 590
San Jose, CA 95131
Tel: 408-436-7950 Fax: 408-436-7955

Toronto

6285 Northam Drive, Suite 108
Mississauga, Ontario L4V 1X5, Canada
Tel: 905-673-0699 Fax: 905-673-6509

ASIA/PACIFIC

Australia

Microchip Technology Australia Pty Ltd
Suite 22, 41 Rawson Street
Epping 2121, NSW
Australia
Tel: 61-2-9868-6733 Fax: 61-2-9868-6755

China - Beijing

Microchip Technology Consulting (Shanghai)
Co., Ltd., Beijing Liaison Office
Unit 915
Bei Hai Wan Tai Bldg.
No. 6 Chaoyangmen Beidajie
Beijing, 100027, No. China
Tel: 86-10-85282100 Fax: 86-10-85282104

China - Chengdu

Microchip Technology Consulting (Shanghai)
Co., Ltd., Chengdu Liaison Office
Rm. 2401, 24th Floor,
Ming Xing Financial Tower
No. 88 TIDU Street
Chengdu 610016, China
Tel: 86-28-6766200 Fax: 86-28-6766599

China - Fuzhou

Microchip Technology Consulting (Shanghai)
Co., Ltd., Fuzhou Liaison Office
Unit 28F, World Trade Plaza
No. 71 Wusi Road
Fuzhou 350001, China
Tel: 86-591-7503506 Fax: 86-591-7503521

China - Shanghai

Microchip Technology Consulting (Shanghai)
Co., Ltd.
Room 701, Bldg. B
Far East International Plaza
No. 317 Xian Xia Road
Shanghai, 200051
Tel: 86-21-6275-5700 Fax: 86-21-6275-5060

China - Shenzhen

Microchip Technology Consulting (Shanghai)
Co., Ltd., Shenzhen Liaison Office
Rm. 1315, 13/F, Shenzhen Kerry Centre,
Renminnan Lu
Shenzhen 518001, China
Tel: 86-755-2350361 Fax: 86-755-2366086

Hong Kong

Microchip Technology Hongkong Ltd.
Unit 901-6, Tower 2, Metroplaza
223 Hing Fong Road
Kwai Fong, N.T., Hong Kong
Tel: 852-2401-1200 Fax: 852-2401-3431

India

Microchip Technology Inc.
India Liaison Office
Divyasree Chambers
1 Floor, Wing A (A3/A4)
No. 11, O'Shaugnessey Road
Bangalore, 560 025, India
Tel: 91-80-2290061 Fax: 91-80-2290062

Japan

Microchip Technology Japan K.K.
Benex S-1 6F
3-18-20, Shinyokohama
Kohoku-Ku, Yokohama-shi
Kanagawa, 222-0033, Japan
Tel: 81-45-471-6166 Fax: 81-45-471-6122

Korea

Microchip Technology Korea
168-1, Youngbo Bldg. 3 Floor
Samsung-Dong, Kangnam-Ku
Seoul, Korea 135-882
Tel: 82-2-554-7200 Fax: 82-2-558-5934

Singapore

Microchip Technology Singapore Pte Ltd.
200 Middle Road
#07-02 Prime Centre
Singapore, 188980
Tel: 65-334-8870 Fax: 65-334-8850

Taiwan

Microchip Technology Taiwan
11F-3, No. 207
Tung Hua North Road
Taipei, 105, Taiwan
Tel: 886-2-2717-7175 Fax: 886-2-2545-0139

EUROPE

Denmark

Microchip Technology Nordic ApS
Regus Business Centre
Lautrup høj 1-3
Ballerup DK-2750 Denmark
Tel: 45 4420 9895 Fax: 45 4420 9910

France

Microchip Technology SARL
Parc d'Activite du Moulin de Massy
43 Rue du Saule Trapu
Batiment A - 1er Etage
91300 Massy, France
Tel: 33-1-69-53-63-20 Fax: 33-1-69-30-90-79

Germany

Microchip Technology GmbH
Gustav-Heinemann Ring 125
D-81739 Munich, Germany
Tel: 49-89-627-144 0 Fax: 49-89-627-144-44

Italy

Microchip Technology SRL
Centro Direzionale Colleoni
Palazzo Taurus 1 V. Le Colleoni 1
20041 Agrate Brianza
Milan, Italy
Tel: 39-039-65791-1 Fax: 39-039-6899883

United Kingdom

Arizona Microchip Technology Ltd.
505 Eskdale Road
Winnersh Triangle
Wokingham
Berkshire, England RG41 5TU
Tel: 44 118 921 5869 Fax: 44-118 921-5820

01/18/02