

BLF041SYC-12V-P SUPER BRIGHT YELLOW

### Features

- BUILT-IN CURRENT LIMITING RESISTOR FOR DIRECT APPLICATION OF DIFFERENT ACROSS CURRENT.
- LONG LIFE.
- LOW CURRENT, POWER SAVINGS.
- LOW MAINTENANCE.
- DIFFERENT COLOR AVAILABLE.
- SOLID STATE, HIGH VIBRATION RESISTANT.
- 12V INTERNAL RESISTOR.

### Description

The Super Bright Yellow source color devices are made with DH InGaAlP on GaAs substrate Light Emitting Diode.

### Package Dimensions

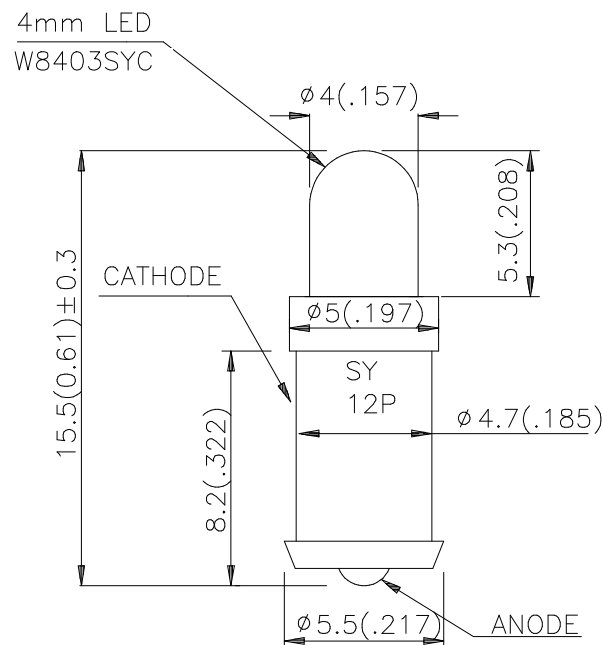

#### Notes:

1. All dimensions are in millimeters (inches).
2. Tolerance is  $\pm 0.25(0.01)$  unless otherwise noted.
3. Specifications are subject to change without notice.

## Selection Guide

Part No.	Dice	Lens Type	Iv (mcd) V=12V		Viewing Angle
			Min.	Typ.	2θ1/2
BLF041SYC-12V-P	SUPER BRIGHT YELLOW (InGaAlP)	WATER CLEAR	280	700	30°

Note:

1. θ1/2 is the angle from optical centerline where the luminous intensity is 1/2 the optical centerline value.

## Electrical / Optical Characteristics at T<sub>A</sub>=25°C

Symbol	Parameter	Device	Typ.	Max.	Units	Test Conditions
λ <sub>peak</sub>	Peak Wavelength	Super Bright Yellow	590		nm	V <sub>F</sub> =12V
λ <sub>D</sub>	Dominate Wavelength	Super Bright Yellow	588		nm	V <sub>F</sub> =12V
Δλ <sub>1/2</sub>	Spectral Line Half-width	Super Bright Yellow	28		nm	V <sub>F</sub> =12V
I <sub>F</sub>	Forward Current	Super Bright Yellow	18		mA	V <sub>F</sub> =12V
I <sub>R</sub>	Reverse Current	Super Bright Yellow		10	μA	V <sub>R</sub> = 5V

## Absolute Maximum Ratings at T<sub>A</sub>=25°C

Parameter	Super Bright Yellow	Units
Power dissipation for 12V	300	mW
Forward Voltage for 12V	14	V
Reverse Voltage	5	V
Operating Temperature	-40°C To +70°C	
Storage Temperature	-40°C To +85°C	

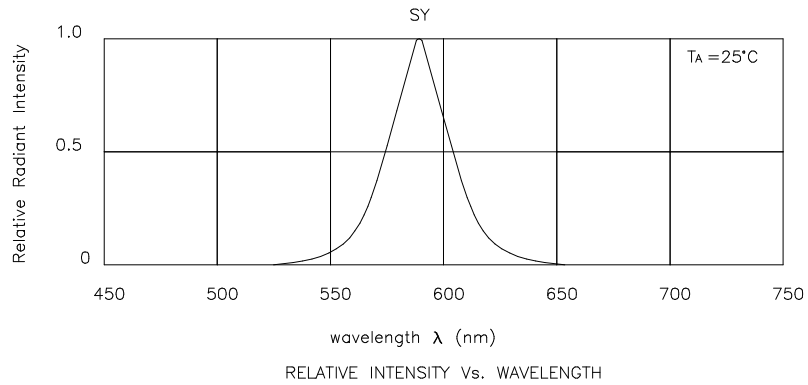

## Super Bright Yellow BLF041SYC-12V-P

