

Stand Alone LIN Transceiver

Description

The NCV7321 is a fully featured local interconnect network (LIN) transceiver designed to interface between a LIN protocol controller and the physical bus. The transceiver is implemented in I3T technology enabling both high-voltage analog circuitry and digital functionality to co-exist on the same chip.

The NCV7321 LIN device is a member of the in-vehicle networking (IVN) transceiver family. It is designed to work in harsh automotive environment and is submitted to the TS16949 qualification flow.

The LIN bus is designed to communicate low rate data from control devices such as door locks, mirrors, car seats, and sunroofs at the lowest possible cost. The bus is designed to eliminate as much wiring as possible and is implemented using a single wire in each node. Each node has a slave MCU-state machine that recognizes and translates the instructions specific to that function. The main attraction of the LIN bus is that all the functions are not time critical and usually relate to passenger comfort.

Features

- General
 - ◆ SOIC-8 Green package (Pb-Free)
- LIN-Bus Transceiver
 - ◆ LIN Compliant to Specification Revision 2.0 and 2.1 (Backwards Compatible to Version 1.3) and J2602
 - ◆ Bus Voltage ± 45 V
 - ◆ Transmission Rate 1 kbps to 20 kbps
- Protection
 - ◆ Thermal Shutdown
 - ◆ Indefinite Short-Circuit Protection on Pins LIN and WAKE Towards Supply and Ground
 - ◆ Load Dump Protection (45 V)
 - ◆ Bus Pins Protected Against Transients in an Automotive Environment
- EMI Compatibility
 - ◆ Integrated Slope Control
- Modes
 - ◆ Normal Mode: LIN Transceiver Enabled, Communication via the LIN Bus is Possible, INH Switch is On



ON Semiconductor®

<http://onsemi.com>

PIN ASSIGNMENT

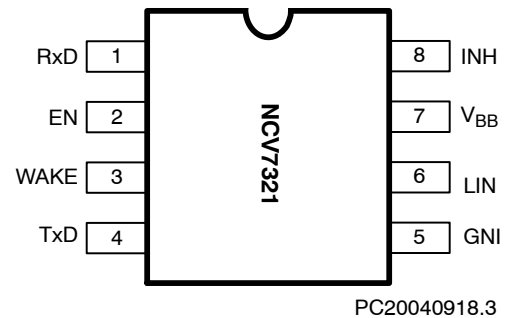

(Top View)

ORDERING INFORMATION

See detailed ordering and shipping information in the package dimensions section on page 11 of this data sheet.

- ◆ Sleep Mode: LIN Transceiver Disabled, the Consumption from V_{BB} is Minimized, INH Switch is Off
- ◆ Standby Mode: transition mode reached either after power-up or after a wakeup event, INH switch is on
- ◆ Wake-up Bringing the Component from Sleep Mode into Standby Mode is Possible either by LIN Command, a Digital Signal on WAKE Pin (e.g. External Switch) or Directly via EN pin.

KEY TECHNICAL CHARACTERISTICS AND OPERATING RANGES

Table 1. TECHNICAL CHARACTERISTICS

Symbol	Parameter	Min	Typ	Max	Unit
V _{BB}	Nominal Battery Operating Voltage (Note 1)	5	12	27	V
	Load Dump Protection (Note 2)			45	
I _{BB_SLP}	Supply Current in Sleep Mode			20	μA
V _{WAKE}	Operating DC Voltage on WAKE Pin	0		V _{BB}	V
	Maximum Rating Voltage on WAKE Pin	-45		45	V
V _{INH}	Operating DC Voltage on INH Pin	0		V _{BB}	V
V _{Dig_IO}	Operating DC Voltage on Digital IO Pins (EN, RxD, TxD)	0		5.5	V
T _J	Junction Thermal Shutdown Temperature		165		°C
T _{amb}	Operating Ambient Temperature	-40		+125	°C
V _{ESD}	Electrostatic Discharge Voltage (LIN, WAKE, V _{BB}) System Human Body Model (Note 3)	-5		+5	kV
	Electrostatic Discharge Voltage (all pins) Human Body Model (Note 4)	-4		+4	

- Below 5 V on V_{BB} in normal mode, the bus will either stay recessive or comply with the voltage level specifications and transition time specifications as required by SAE J2602. It is ensured by the battery monitoring circuit (see par. 7.2.3).
- The applied transients shall be in accordance with ISO 7637 part 1, test pulse 5. The device complies with functional class C; class A can be reached depending on the application and external components.
- Equivalent to discharging a 150 pF capacitor through a 330 Ω resistor conform to IEC Standard 1000-4-2. Additional external protection components might be needed to reach the specified system ESD levels depending on the application. WAKE pin is stressed through a 33 kΩ resistor.
- Equivalent to discharging a 100 pF capacitor through a 1.5k Ω resistor conform to MIL STD 883 method 3015.7.

BLOCK DIAGRAM

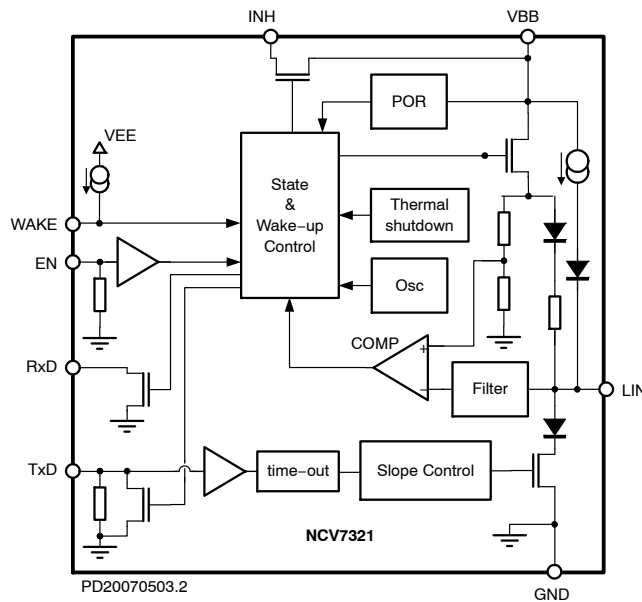

Figure 1. Block Diagram

TYPICAL APPLICATION

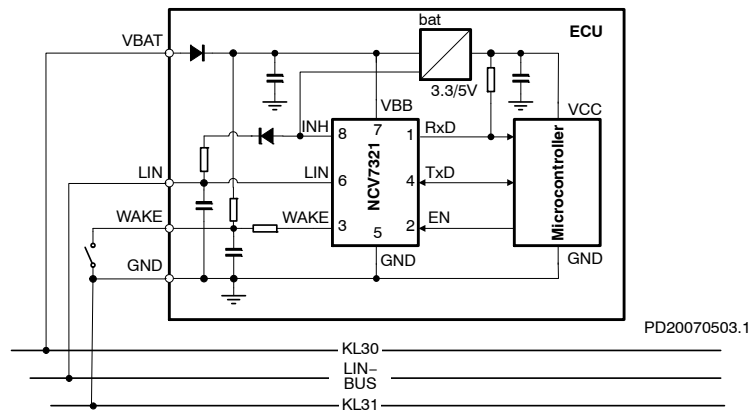

Figure 2. Typical Application Diagram for a Master Node

Table 2. PIN DESCRIPTION

Pin	Name	Description
1	RxD	Receive Data Output; Low in Dominant State; Open-Drain Output
2	EN	Enable Input, Transceiver in Normal Operation Mode when High, Pulldown Resistor to GND
3	WAKE	High Voltage Digital Input Pin to Apply Local Wakeup, Sensitive to Falling Edge, Pullup Current Source to V _{BB}
4	TxD	Transmit Data Input, Low for Dominant State, Pulldown to GND (Switchable Strength for Wakeup Source Recognition)
5	GND	Ground
6	LIN	LIN Bus Output/Input
7	V _{BB}	Battery Supply Input
8	INH	Inhibit Output, Switch Between INH and V _{BB} can be Used to Control External Regulator or Pullup Resistor on LIN Bus

Table 3. ABSOLUTE MAXIMUM RATINGS

Symbol	Parameter	Min	Max	Unit
V _{BB}	Battery Voltage on Pin V _{BB} (Note 5)	-0.3	+45	V
V _{LIN}	LIN Bus Voltage (Note 6)	-45	+45	V
V _{INH}	DC Voltage on inhibit Pin	-0.3	V _{BB} + 0.3	V
V _{WAKE}	DC Voltage on WAKE Pin	-35	45	V
V _{Dig_IO}	DC Input Voltage on Pins TxD, RxD, and EN	-0.3	7	V
T _J	Maximum Junction Temperature	-40	+150	°C
V _{ESD}	Electrostatic Discharge Voltage (Pins LIN, WAKE and V _{BB}) System Human Body Model (Note 7)	-5	+5	kV
	Electrostatic Discharge Voltage (All Pins) Human Body Model (Note 8)	-4	+4	kV
	Electrostatic Discharge Voltage; Charge Device Model (Note 9)	-500	+500	V

Stresses exceeding Maximum Ratings may damage the device. Maximum Ratings are stress ratings only. Functional operation above the Recommended Operating Conditions is not implied. Extended exposure to stresses above the Recommended Operating Conditions may affect device reliability.

5. The applied transients shall be in accordance with ISO 7637 part 1, test pulses 1, 2, 3a, 3b, and 5. The device complies with functional class C; class A can be reached depending on the application and external components.
6. The applied transients shall be in accordance with ISO 7637 part 1, test pulses 1, 2, 3a, and 3b. The device complies with functional class C; class A can be reached depending on the application and external components.
7. Equivalent to discharging a 150 pF capacitor through a 330 Ω resistor conform to IEC Standard 1000-4-2. Additional external protection components might be needed to reach the specified system ESD levels depending on the application. WAKE pin is stressed through a 33 kΩ resistor.
8. Equivalent to discharging a 100 pF capacitor through a 1.5kΩ resistor conform to MIL STD 883 method 3015.7.
9. Conform to EOS/ESD-DS5.3 (socketed mode).

FUNCTIONAL DESCRIPTION

Overall Functional Description

LIN is a serial communication protocol that efficiently supports the control of mechatronic nodes in distributed automotive applications. The domain is class-A multiplex buses with a single master node and a set of slave nodes.

The NCV7321 contains the LIN transmitter, LIN receiver, power-on-reset (POR) circuits and thermal shutdown (TSD). The LIN transmitter is optimized for the maximum specified transmission speed of 20 kB with EMC performance due to reduced slew rate of the LIN output.

The junction temperature is monitored via a thermal shutdown circuit that switches the LIN transmitter off when temperature exceeds the TSD trigger level.

The NCV7321 has four operating states (unpowered mode, standby mode, normal mode and sleep mode) that are determined by the supply voltage V_{BB} , input signals EN and WAKE and activity on the LIN bus.

OPERATING STATES

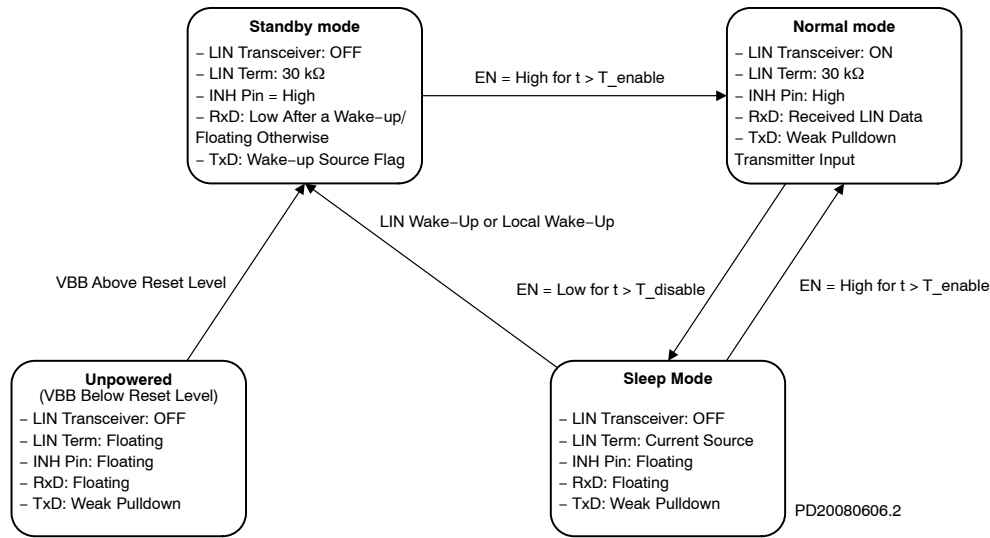

Figure 3. State Diagram

Unpowered Mode

As long as V_{BB} remains below its power-on-reset level, the chip is kept in a safe unpowered state. LIN transmitter is inactive, both LIN and INH pins are left floating and only a weak pulldown is connected on pin TxD. Pin RxD remains floating.

The unpowered state will be entered from any other state when V_{BB} falls below its power-on-reset level.

Standby Mode

Standby mode is a low-power mode, where LIN transceiver remains inactive while INH pin is driven high to activate an external voltage regulator – see Figure 2. Depending on the transition which led to the standby mode, pins RxD and TxD are configured differently during this mode. A 30 kΩ resistor in series with a reverse-protection diode is internally connected between LIN and V_{BB} Pins.

Standby mode is entered in one of the following ways:

- After the voltage level at V_{BB} pin rises above its power-on-reset level. In this case, RxD Pin remains

high-impedant and the pulldown applied on pin TxD remains weak.

- After a wakeup event is recognized while the chip was in the sleep mode. Pin RxD is pulled low while pin TxD signals the type of wakeup leading to the standby mode – its pullup remains weak for LIN wakeup and it is switched to strong pulldown for the case of local wakeup (i.e. wakeup via Pin WAKE).

While in the standby mode, the configuration of Pins RxD and TxD remains unchanged, regardless the activity on WAKE and LIN Pins – i.e. if additional wakeups occur during the standby mode, they have no influence on the chip configuration.

Normal Mode

In normal mode, the full functionality of the LIN transceiver is available. Data according the state of TxD input are sent to the LIN bus while pin RxD reflects the logical symbol received on the LIN bus – high-impedant for recessive and Low for dominant. A 30 kΩ resistor in series

with a reverse-protection diode is internally connected between LIN and V_{BB} pins.

To avoid that, due to a failure of the application (e.g. software error), the LIN bus is permanently driven dominant and thus blocking all subsequent communication, signal on pin TxD passes through a timer, which releases the bus in case TxD remains low for longer than $T_{TxD_timeout}$. The transmission can continue once the TxD returns to High logical level.

In case the junction temperature increases above the thermal shutdown threshold, e.g. due to a short of the LIN wiring to the battery, the transmitter is disabled and releases LIN bus to recessive. Once the junction temperature decreases back below the thermal shutdown release level, the transmission can be enabled again – however, to avoid thermal oscillations, first a High logical level on TxD must be encountered before the transmitter is enabled.

As required by SAE J2602, the transceiver must behave safely below its operating range – it shall either continue to transmit correctly (according its specification) or remain silent (transmit a recessive state regardless the of the TxD signal). A battery monitoring circuit in NCV7321 de-activates the transmitter in the normal mode if the V_{BB} level drops below $MONL_V_{BB}$. Transmission is enabled again when V_{BB} reaches $MONH_V_{BB}$. The internal logic remains in the normal mode and the reception from the LIN line is still possible even if the battery monitor disables the transmission. Although the specifications of the monitoring and power-on-reset levels are overlapping, it's ensured by the implementation that the monitoring level never falls below the power-on-reset level.

Normal mode can be entered from either standby or sleep mode when EN Pin is High for longer than T_{enable} . When the transition is made from standby mode, TxD pulldown is set to weak and RxD is put high-impedant immediately after EN becomes High (before the expiration of T_{enable} filtering time). This excludes signal conflicts between the

standby mode pin settings and the signals required to control the chip in the normal mode (e.g. strong pull-down on TxD after local wakeup vs. High logical level on TxD required to send a recessive symbol on LIN).

Sleep Mode

Sleep mode provides extremely low current consumption. The LIN transceiver is inactive and the battery consumption is minimized. Pin INH is put to high-impedant state to disable the external regulator and, in case of a master node, the LIN termination – see Figure 2. Only a weak pullup current source is internally connected between LIN and V_{BB} Pins, in order to minimize current consumption even in case of LIN short to GND.

Sleep mode can be entered from normal mode by assigning Low logical level to pin EN for longer than $T_{disable}$. The sleepmode can be entered even if a permanent short occurs either on LIN or WAKE Pin.

If a wakeup event occurs during the transition between normal and sleep mode (during the $T_{disable}$ filtering time), it will be regarded as valid wakeup and the chip will enter standby mode with the appropriate setting of Pins RxD and TxD.

Wake-up

Two types of wakeup events are recognized by NCV7321:

- Local wakeup – when a high-to-low transition on pin WAKE is encountered and WAKE pin remains Low at least during T_{WAKE} – see Figure 5.
- Different threshold parameters apply compared to the receiver in the normal mode (see parameters $V_{rec_rec_slp}$ and $V_{rec_hys_slp}$)

Wakeup events can be exclusively detected in sleep mode or during the transition from normal mode to sleep mode. Due to timing tolerances, valid wakeup events beginning shortly before normal-to-sleep mode transition can be also sometimes regarded as valid wakeups.

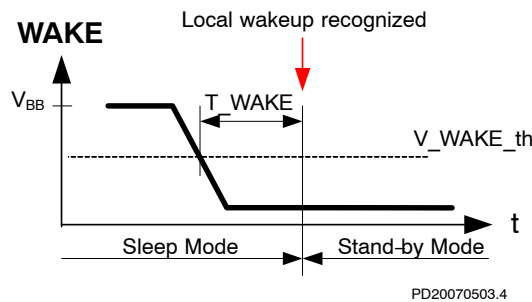

Figure 4. Local Wakeup Detection

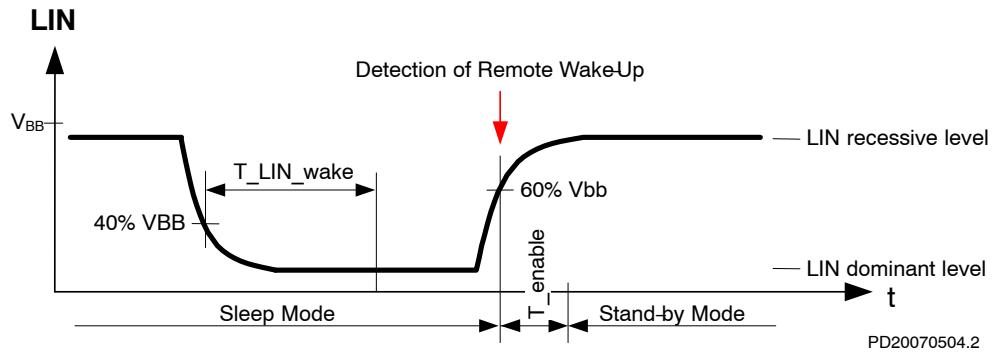

Figure 5. Remote (LIN) Wakeup Detection

ELECTRICAL CHARACTERISTICS

Definitions

All voltages are referenced to GND (Pin 5). Positive currents flow into the IC.

Table 4. DC CHARACTERISTICS (V_{BB} = 5 V to 27 V; T_J = -40°C to +150°C; unless otherwise specified. Typical values are given at V(V_{BB}) = 12 V and T_J = 25°C, unless specified otherwise.)

DC CHARACTERISTICS – SUPPLY

Symbol	Parameter	Conditions	Min	Typ	Max	Unit
V_{BB}						
I _{BB_ON_rec}	V _{BB} Consumption	Normal Mode; LIN recessive V _{LIN} = V(V _{BB}) = V _{INH} = V _{WAKE}			1.6	mA
I _{BB_ON_dom}	V _{BB} Consumption	Normal Mode; LIN dominant V(V _{BB}) = V _{INH} = V _{WAKE}			8	mA
I _{BB_STB}	V _{BB} Consumption	Standby Mode V _{LIN} = V(V _{BB}) = V _{INH} = V _{WAKE}			350	μA
I _{BB_SLP}	V _{BB} Consumption	Sleep Mode V _{LIN} = V(V _{BB}) = V _{INH} = V _{WAKE}			30	μA
I _{BB_SLP_18V}	V _{BB} Consumption	Sleep Mode, V _{BB} < 18 V V _{LIN} = V(V _{BB}) = V _{INH} = V _{WAKE}			20	μA
I _{BB_SLP_12V}	V _{BB} Consumption	Sleep Mode, V _{BB} = 12 V, T _J < 85°C V _{LIN} = V(V _{BB}) = V _{INH} = V _{WAKE}			10	μA

LIN TRANSMITTER

V _{LIN_dom_LoSUp}	LIN Dominant Output Voltage	TXD = Low; V _{BB} = 7.3 V			1.2	V
V _{LIN_dom_HiSup}	LIN Dominant Output Voltage	TXD = Low; V _{BB} = 18 V			2.0	V
V _{LIN_REC}	LIN Recessive Output Voltage	TXD = HighH; I _{LIN} = 0 mA		V _{BB} - V _γ (Note 10)		V
I _{LIN_lim}	Short Circuit Current Limitation	V _{LIN} = V _{BB_max}	40		200	mA
R _{slave}	Internal Pullup Resistance		20	33	47	kΩ
I _{LIN_off_dom}	LIN output current, bus in dominant state	Normal Mode, Driver Off; V _{BB} = 12 V	-1			mA
I _{LIN_off_dom_slp}	LIN Output Current, Bus in Dominant State	Sleep Mode, Driver Off; V _{BB} = 12 V	-20	-15	-2	μA

10. V_γ is the forward diode voltage. Typically (over the complete temperature) V_γ = 1 V.

NCV7321

www.DataSheet4U.com **Table 4. DC CHARACTERISTICS** ($V_{BB} = 5\text{ V to }27\text{ V}$; $T_J = -40^\circ\text{C to }+150^\circ\text{C}$; unless otherwise specified. Typical values are given at $V(V_{BB}) = 12\text{ V}$ and $T_J = 25^\circ\text{C}$, unless specified otherwise.)

DC CHARACTERISTICS – SUPPLY

Symbol	Parameter	Conditions	Min	Typ	Max	Unit
LIN TRANSMITTER						
ILIN_off_rec	LIN Output Current, Bus in Recessive State	Driver Off; $V_{BB} = 12\text{ V}$			5	μA
ILIN_no_GND	Communication not Affected	$V_{BB} = \text{GND} = 12\text{ V}$; $0 < V_{LIN} < 18\text{ V}$	-1		1	mA
ILIN_no_VBB	LIN Bus Remains Operational	$V_{BB} = \text{GND} = 0\text{ V}$; $0 < V_{LIN} < 18\text{ V}$			100	μA

LIN RECEIVER

Vrec_dom	Receiver Threshold	LIN Bus Recessive – Dominant	0.4		0.5	V_{BB}
Vrec_rec	Receiver Threshold	LIN Bus Dominant – Recessive	0.5		0.6	V_{BB}
Vrec_cnt	Receiver Centre Voltage	$(V_{bus_dom} + V_{bus_rec})/2$	0.475		0.525	V_{BB}
Vrec_hys	Receiver Hysteresis	$(V_{bus_rec} - V_{bus_dom})$	0.05		0.175	V_{BB}

DC CHARACTERISTICS – I/Os

Symbol	Parameter	Conditions	Min	Typ	Max	Unit
PIN EN						
Vil_EN	Low Level Input Voltage		-0.3		0.8	V
Vih_EN	High Level Input Voltage		2.0		5.5	V
Rpd_EN	Pulldown Resistance to Ground (Note 10)		150	350	650	$\text{k}\Omega$

PIN INH

Delta_VH	High Level Voltage Drop	$I_{INH} = 15\text{ mA}$, INH Active	0.1	0.35	0.75	V
I_leak	Leakage Current	Sleep Mode; $V_{INH} = 0\text{ V}$	-1	0	1	μA

PIN RxD

Iol_RxD	Low Level Output Current	$V_{RxD} = 0.4\text{ V}$, normal mode, $V_{LIN} = 0\text{ V}$	1.5			mA
Ioh_RxD	High Level Output Current	$V_{RxD} = 5\text{ V}$, Normal Mode, $V_{LIN} = V(V_{BB})$	-5	0	5	μA

PINS TxD

Vil_TxD	Low Level Input Voltage		-0.3		0.8	V
Vih_TxD	High Level Input Voltage		2.0		5.5	V
Rpd_TxD	Pulldown Resistor on TxD Pin, Corresponding to "Weak Pulldown"	Normal Mode or Sleep Mode or Standby Mode after Powerup or Standby Mode after LIN Wakeup	150	350	650	$\text{k}\Omega$
Ipd_RxD_Strong	Pulldown Current on TxD Pin Corresponding to "Strong Pulldown"	Standby Mode after Local Wakeup	1.5			mA

10. V_f is the forward diode voltage. Typically (over the complete temperature) $V_f = 1\text{ V}$.

NCV7321

www.DataSheet4U.com **Table 4. DC CHARACTERISTICS** ($V_{BB} = 5\text{ V to }27\text{ V}$; $T_J = -40^\circ\text{C to }+150^\circ\text{C}$; unless otherwise specified. Typical values are given at $V(V_{BB}) = 12\text{ V}$ and $T_J = 25^\circ\text{C}$, unless specified otherwise.)

DC CHARACTERISTICS – I/Os

Symbol	Parameter	Conditions	Min	Typ	Max	Unit
PIN WAKE						
V_wake_th	WAKE Threshold Voltage		$V_{BB} - 3.3$		$V_{BB} - 1.1$	V
I_wake_pullup	Pullup Current on Pin WAKE	$V_{WAKE} = 0\text{ V}$	-30	-15	-1	μA
I_wake_leak	Leakage of Pin WAKE	$V_{WAKE} = V(V_{BB})$	-5	0	5	μA

DC CHARACTERISTICS – POWER-ON-RESET, BATTERY MONITORING AND THERMAL SHUTDOWN

Symbol	Parameter	Conditions	Min.	Typ.	Max.	Unit
POR AND V_{BB} MONITOR						
PORH_ V_{BB}	Power-on Reset High Level on V_{BB}	V_{BB} Rising	2		4.5	V
PORL_ V_{BB}	Power-on Reset Low Level on V_{BB}	V_{BB} Falling	1.7		4	V
MONH_ V_{BB}	Battery Monitoring High Level	V_{BB} Rising			4.5	
MONL_ V_{BB}	Battery Monitoring Low Level	V_{BB} Falling	3			
TSD						
T_J	Junction Temperature	Temperature Rising		165		$^\circ\text{C}$
T_{J_hyst}	Thermal Shutdown Hysteresis		9		18	$^\circ\text{C}$

10. V_f is the forward diode voltage. Typically (over the complete temperature) $V_f = 1\text{ V}$.

NCV7321

www.DataSheet4U.com **Table 5. AC CHARACTERISTICS** $V_{BB} = 5\text{ V to }27\text{ V}$; $T_J = -40^\circ\text{C to }+150^\circ\text{C}$; unless otherwise specified. For the transmitter parameters, the following bus loads are considered: $L1 = 1\text{ k}\Omega / 1\text{ nF}$; $L2 = 660\ \Omega / 6.8\text{ nF}$; $L3 = 500\ \Omega / 10\text{ nF}$

Symbol	Parameter	Conditions	Min	Typ	Max	Unit
LIN TRANSMITTER						
D1	Duty Cycle 1 = $t_{BUS_REC(min)} / (2 \times T_{Bit})$	$TH_{REC(min)} = 0.744 \times V_{BB}$ $TH_{DOM(min)} = 0.581 \times V_{BB}$ $T_{BIT} = 50\ \mu\text{s}$ $V(V_{BB}) = 7\text{ V to }18\text{ V}$	0.396		0.5	
D2	Duty Cycle 2 = $t_{BUS_REC(max)} / (2 \times T_{Bit})$	$TH_{REC(max)} = 0.422 \times V_{BB}$ $TH_{DOM(max)} = 0.284 \times V_{BB}$ $T_{BIT} = 50\ \mu\text{s}$ $V(V_{BB}) = 7.6\text{ V to }18\text{ V}$	0.5		0.581	
D3	Duty Cycle 3 = $t_{BUS_REC(min)} / (2 \times T_{Bit})$	$TH_{REC(min)} = 0.788 \times V_{BB}$ $TH_{DOM(min)} = 0.616 \times V_{BB}$ $T_{BIT} = 96\ \mu\text{s}$ $V(V_{BB}) = 7\text{ V to }18\text{ V}$	0.417		0.5	
D4	Duty Cycle 4 = $t_{BUS_REC(max)} / (2 \times T_{Bit})$	$TH_{REC(max)} = 0.389 \times V_{BB}$ $TH_{DOM(max)} = 0.251 \times V_{BB}$ $T_{BIT} = 96\ \mu\text{s}$ $V(V_{BB}) = 7.6\text{ V to }18\text{ V}$	0.5		0.590	
T_fall	LIN Falling Edge	Normal Mode; $V_{BB} = 12\text{ V}$			22.5	μs
T_rise	LIN Rising Edge	Normal Mode; $V_{BB} = 12\text{ V}$			22.5	μs
T_sym	LIN Slope Symmetry	Normal Mode; $V_{BB} = 12\text{ V}$	-4	0	4	μs
LIN Receiver						
Trec_prop_down	Propagation Delay of Receiver Falling Edge		0.1		6	μs
Trec_prop_up	Propagation Delay of Receiver Rising Edge		0.1		6	μs
Trec_sym	Propagation Delay Symmetry	$Trec_prop_down - Trec_prop_up$	-2		2	μs

MODE TRANSITIONS TIMEOUTS

T_LIN_wake	Duration of LIN Dominant for Detection of wake-up via LIN bus	Sleep Mode	30	90	150	μs
T_WAKE	Duration of Low level on WAKE Pin for local wakeup detection	Sleep Mode	7		50	μs
T_enable	Duration of High Level on EN Pin for Transition to Normal Mode		2	5	10	μs
T_disable	Duration of Low Level on EN Pin for Transition to Sleep Mode		2	5	10	μs
T_TxD_timeout	TxD Dominant Time-Out	Normal Mode, TxD = low, Guarantees Baudrate as Low as 1 kbps	15		50	ms

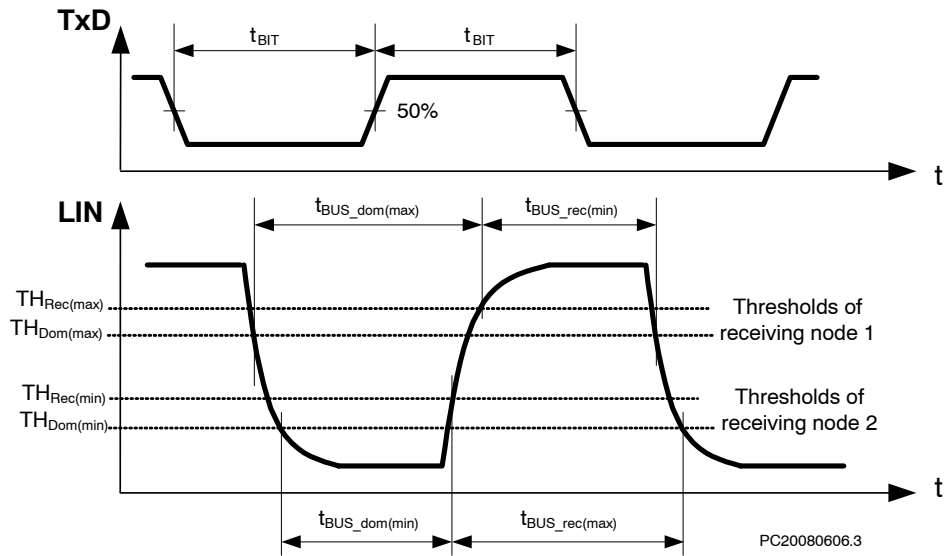

Figure 6. LIN Transmitter Duty Cycle

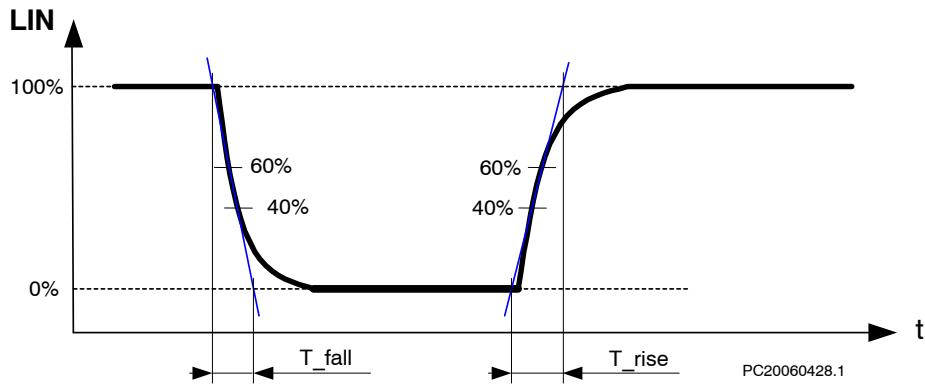

Figure 7. LIN Transmitter Rising and Falling Times

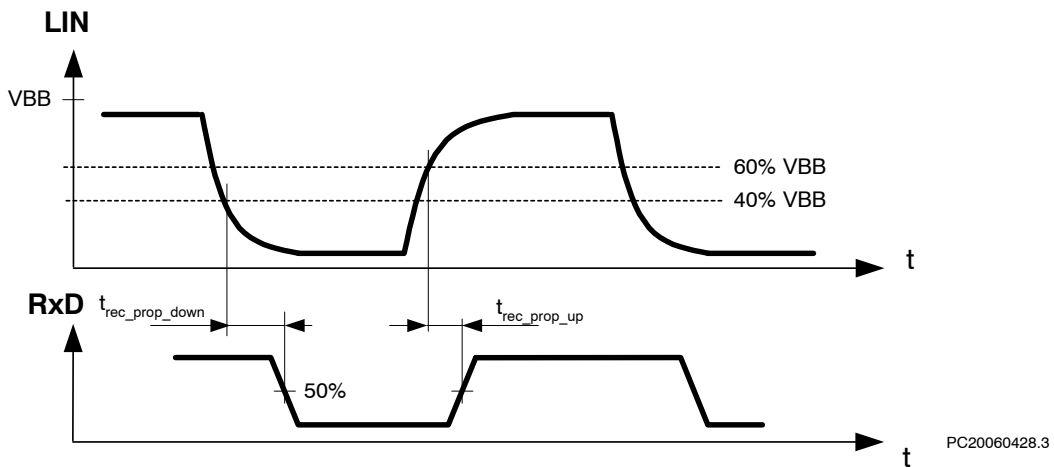

Figure 8. LIN Receiver Timing

NCV7321

www.DataSheet4U.com **DEVICE ORDERING INFORMATION**

Part Number	Temperature Range	Package Type	Shipping [†]
NCV7321D10G	-40°C - 125°C	SOIC-8 (Pb-Free)	96 Tube / Tray
NCV7321D10R2G	-40°C - 125°C	SOIC-8 (Pb-Free)	3000 / Tape & Reel

[†]For information on tape and reel specifications, including part orientation and tape sizes, please refer to our Tape and Reel Packaging Specifications Brochure, BRD8011/D.

NCV7321

PACKAGE DIMENSIONS

SOIC 14
CASE 751AP-01
ISSUE A

DATE 29 AUG 2008

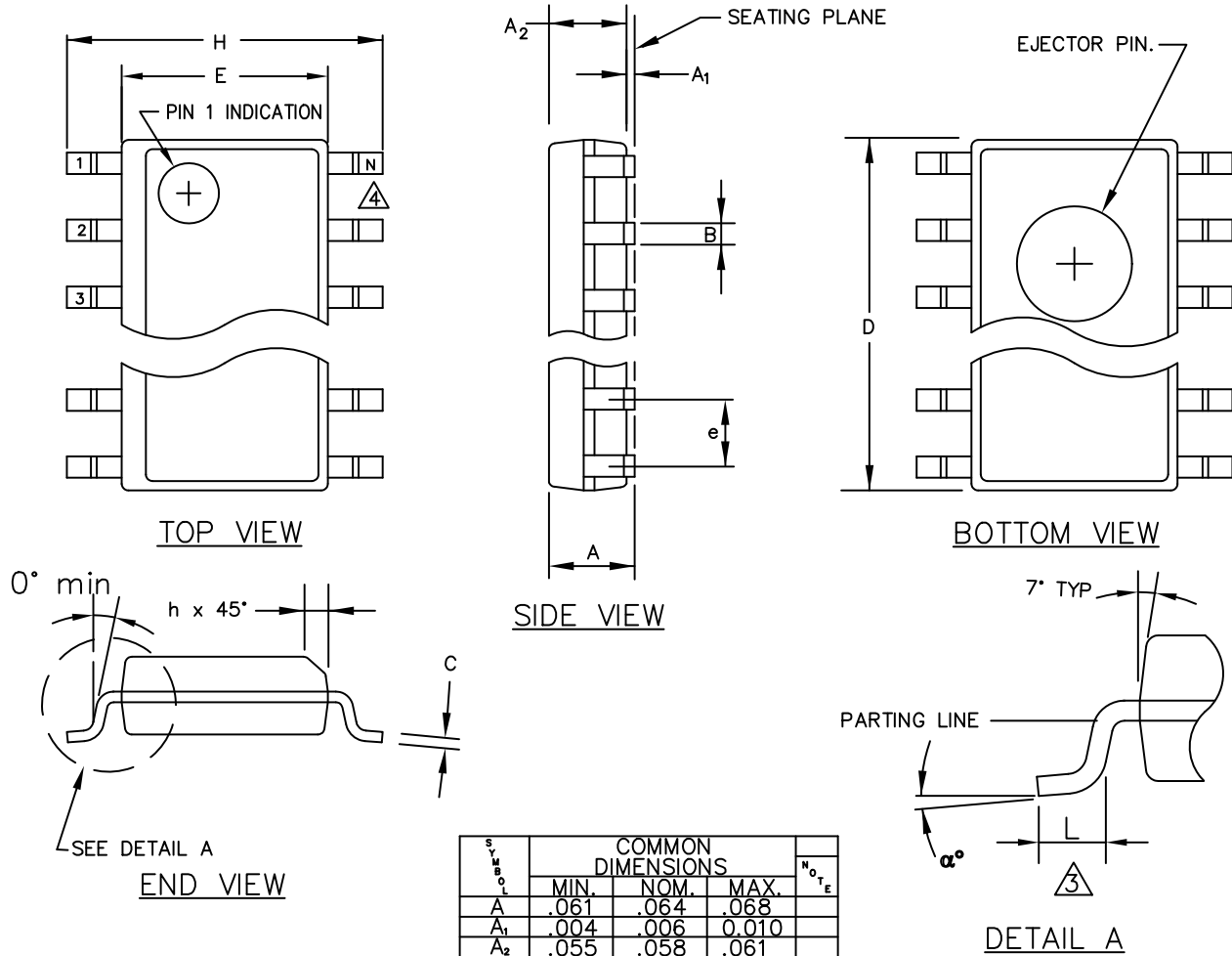

SYMBOL	COMMON DIMENSIONS			NOTE
	MIN.	NOM.	MAX.	
A	.061	.064	.068	
A ₁	.004	.006	0.010	
A ₂	.055	.058	.061	
B	.0138	.016	.020	
C	.0075	.008	.0098	
D	SEE VARIATIONS			1
E	.150	.155	.157	
e	.050 BSC			
H	.230	.236	.244	
h	.010	.013	.016	
L	.016	.025	.035	
N	SEE VARIATIONS			2
α°	0°	5°	8°	

VARIATIONS				
	1			2
	D			N
NOTE	MIN.	NOM.	MAX.	
AA	.189	.194	.196	8
AB	.337	.342	.344	14
AC	.386	.391	.393	16

NCV7321

www.DataSheet4U.com

ON Semiconductor and  are registered trademarks of Semiconductor Components Industries, LLC (SCILLC). SCILLC reserves the right to make changes without further notice to any products herein. SCILLC makes no warranty, representation or guarantee regarding the suitability of its products for any particular purpose, nor does SCILLC assume any liability arising out of the application or use of any product or circuit, and specifically disclaims any and all liability, including without limitation special, consequential or incidental damages. "Typical" parameters which may be provided in SCILLC data sheets and/or specifications can and do vary in different applications and actual performance may vary over time. All operating parameters, including "Typicals" must be validated for each customer application by customer's technical experts. SCILLC does not convey any license under its patent rights nor the rights of others. SCILLC products are not designed, intended, or authorized for use as components in systems intended for surgical implant into the body, or other applications intended to support or sustain life, or for any other application in which the failure of the SCILLC product could create a situation where personal injury or death may occur. Should Buyer purchase or use SCILLC products for any such unintended or unauthorized application, Buyer shall indemnify and hold SCILLC and its officers, employees, subsidiaries, affiliates, and distributors harmless against all claims, costs, damages, and expenses, and reasonable attorney fees arising out of, directly or indirectly, any claim of personal injury or death associated with such unintended or unauthorized use, even if such claim alleges that SCILLC was negligent regarding the design or manufacture of the part. SCILLC is an Equal Opportunity/Affirmative Action Employer. This literature is subject to all applicable copyright laws and is not for resale in any manner.

PUBLICATION ORDERING INFORMATION

LITERATURE FULFILLMENT:

Literature Distribution Center for ON Semiconductor
P.O. Box 5163, Denver, Colorado 80217 USA
Phone: 303-675-2175 or 800-344-3860 Toll Free USA/Canada
Fax: 303-675-2176 or 800-344-3867 Toll Free USA/Canada
Email: orderlit@onsemi.com

N. American Technical Support: 800-282-9855 Toll Free
USA/Canada
Europe, Middle East and Africa Technical Support:
Phone: 421 33 790 2910
Japan Customer Focus Center
Phone: 81-3-5773-3850

ON Semiconductor Website: www.onsemi.com
Order Literature: <http://www.onsemi.com/orderlit>
For additional information, please contact your local
Sales Representative