

General Description

The AAT4625 SmartSwitch™ is part of AnalogicTech's Application Specific Power MOSFET™ (ASPM™) product family. It is a 1.0A Current Limited P-channel, MOSFET power switch designed for high-side load-switching applications. This switch operates with inputs ranging from 2.7V to 5.5V, making it ideal for both 3V and 5V systems. An integrated current-limiting circuit protects the input supply against large changes in load current which may cause the supply to fall out of regulation. The AAT4625 is also protected from thermal overload which limits power dissipation and junction temperatures. The current limit threshold is factory programmed at 1.5A, with a maximum of 2.0A. The quiescent supply current is typically a low 16µA. In shutdown mode, the supply current decreases to less than 1µA.

The AAT4625 is available in 8 pin SOP or TSSOP and is specified over a -40 to 85°C temperature range.

The AAT4600 Series is a family of adjustable and fixed SmartSwitch™ products with a range of current handling capabilities. Single versions with adjustable current limit (AAT4601) or fixed current limit (AAT4625) as well as dual versions with fixed current limit (AAT4626) are available.

Features

- Compliant with USB 1.1 and 2.0 specifications
- 2.7V to 5.5V Input voltage range
- 1.0A minimum continuous current
- 2.0A maximum current limit
- 60mΩ typical $R_{DS(ON)}$
- Low quiescent current
 - Typically 16µA
 - 1µA max with Switch off
- Thermal shutdown
- Fault flag with 10ms blanking
- Undervoltage Lockout
- Temp range -40 to 85°C
- UL Approved—File No. E217765
- 8 pin SOP or TSSOP package

Applications

- USB ports and peripherals
- Notebook computers
- Hot swap supplies
- General purpose power switching



UL Recognized Component

Typical Application

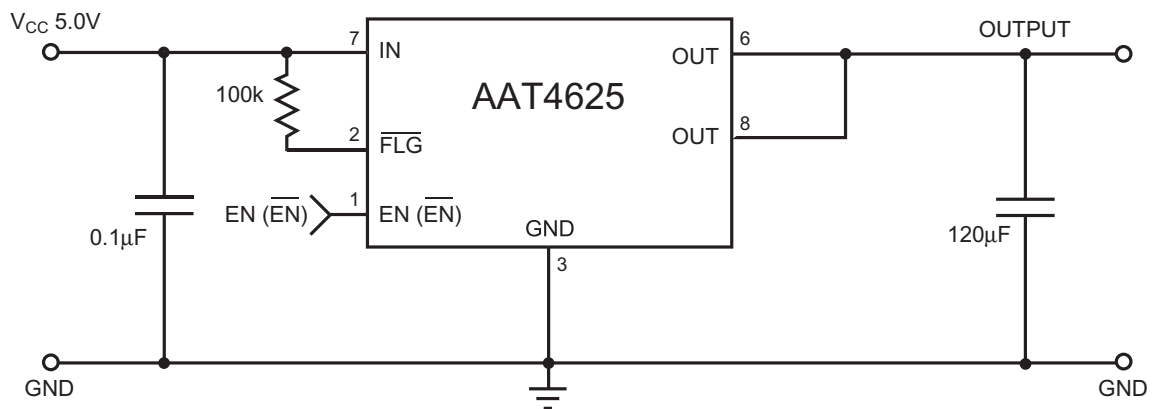

Pin Descriptions

| Pin # | Symbol | Function |
|-------|-------------------------------|---|
| 1 | EN ($\overline{\text{EN}}$) | Enable Input: Logic-compatible enable input. High input > 2.1V typical. Low input < 1.9V typical. Active high or active low option available; see Ordering Information for details. |
| 2 | $\overline{\text{FLG}}$ | Fault Flag Output: Active-low, open-drain output. Indicates over current, UVLO and thermal shutdown. |
| 3 | GND | Ground connection |
| 4,5 | NC | Not internally connected. |
| 6,8 | OUT | Switch Output: These pins are the P-channel MOSFET drain connection. |
| 7 | IN | Supply Input: This pin is the P-channel MOSFET source connection. Also supplies the IC's internal circuitry. |

Pin Configuration

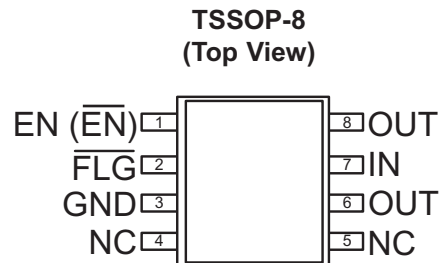
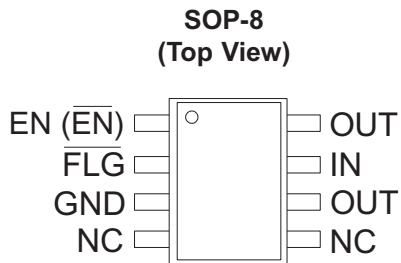

Absolute Maximum Ratings ($T_A=25^\circ\text{C}$ unless otherwise noted)

| Symbol | Description | Value | Units |
|------------|--|----------------------|------------------|
| V_{IN} | IN to GND | -0.3 to 6 | V |
| V_{FLG} | FLG to GND | -0.3 to 6 | V |
| I_{FLG} | FLG Current | 50 | mA |
| V_{OUT} | OUT to GND | -0.3 to $V_{IN}+0.3$ | V |
| I_{OUT} | Output Current (Internally Limited) | 2.0 | A |
| V_{EN} | EN to GND | -0.3 to 6 | V |
| T_S | Storage Temperature | 150 | $^\circ\text{C}$ |
| T_{LEAD} | Maximum Soldering Temperature (at Leads) | 300 | $^\circ\text{C}$ |

Note: Stresses above those listed in Absolute Maximum Ratings may cause permanent damage to the device. Functional operation at conditions other than the operating conditions specified is not implied. Only one Absolute Maximum rating should be applied at any one time.

Thermal Information

| Symbol | Description | Value | Units |
|---------------|---|-------|---------------------------|
| Θ_{JA} | Maximum Thermal Resistance (SOP-8) ¹ | 100 | $^\circ\text{C}/\text{W}$ |
| P_D | Maximum Power Dissipation (SOP-8) ¹ | 1.25 | W |

Note 1: Mounted on an FR4 printed circuit board.

Electrical Characteristics ($V_{IN} = 5\text{V}$, $T_A = -40$ to 85°C unless otherwise noted. Typical values are at $T_A=25^\circ\text{C}$; **bold** values designate full temperature range)

| Symbol | Description | Conditions | Min | Typ | Max | Units |
|----------------|------------------------------|---|------------|------|------------|------------------|
| V_{IN} | Operation Voltage | | 2.7 | | 5.5 | V |
| I_Q | Quiescent Current | $V_{IN}=5\text{V}$, EN=active | | 16 | 30 | μA |
| $I_{Q(OFF)}$ | Off Supply Current | $V_{IN}=5.5\text{V}$, EN ($\overline{\text{EN}}$)=inactive | | | 1 | μA |
| $V_{EN-THRSH}$ | Enable Input Threshold | Low-to-high transition | | | 2.4 | V |
| | | High-to-low transition | 0.8 | | | V |
| I_{EN} | Enable Input Current | $V_{EN} = 0\text{V}$ to 5.5V | | 0.01 | 1 | μA |
| C_{EN} | Enable Input Capacitance | | | 1 | | pF |
| $R_{ds(ON)}$ | On-Resistance | $V_{IN} = 5\text{V}$, $T_A = 25^\circ\text{C}$ | | 60 | 100 | m Ω |
| | | $V_{IN} = 3.0\text{V}$, $T_A = 25^\circ\text{C}$ | | 70 | 115 | m Ω |
| T_{ON} | Output Turn-On Delay | $V_{IN} = 5\text{V}$, $R_L = 10\Omega$ | | 0.25 | | ms |
| $T_{ON-RISE}$ | Output Turn-On Rise Time | $V_{IN} = 5\text{V}$, $R_L = 10\Omega$ | | 0.2 | | ms |
| T_{OFF} | Output Turn-Off Delay | $V_{IN} = 5\text{V}$, $R_L = 10\Omega$ | | 5 | 20 | μs |
| $T_{OFF-FALL}$ | Output Turn-Off Fall Time | $V_{IN} = 5\text{V}$, $R_L = 10\Omega$ | | | 20 | μs |
| $I_{SD(OFF)}$ | Output Leakage Current | EN=inactive, $V_{IN}=5.5\text{V}$, $V_{OUT}=0\text{V}$ | | 0.03 | 15 | μA |
| I_{LIMIT} | Current Limit Threshold | ramped load applied to enable output, $V_{OUT} < 4.0\text{V}$ | 1.0 | 1.5 | 2.0 | A |
| OTMP | Over Temperature Shut Down | T_J increasing | | 125 | | $^\circ\text{C}$ |
| | | T_J decreasing | | 115 | | $^\circ\text{C}$ |
| R_{FLG} | Error Flag Output Resistance | $V_{IN} = 5\text{V}$, $I_L = 1\text{mA}$ | | 30 | | Ω |
| I_{SINK} | Error Flag Off Current | $V_{FLG} = 5.5\text{V}$ | | 0.05 | 1 | μA |
| V_{UVLO} | Under voltage Lockout | $V_{IN} =$ increasing, 1% hysteresis | 2.0 | 2.3 | 2.7 | V |
| T_{BLANK} | FAULT blanking | | | 10 | | ms |

Typical Characteristics

(Unless otherwise noted, $V_{IN} = 5V$, $T_A = 25^\circ C$)

Quiescent Current vs. Temperature

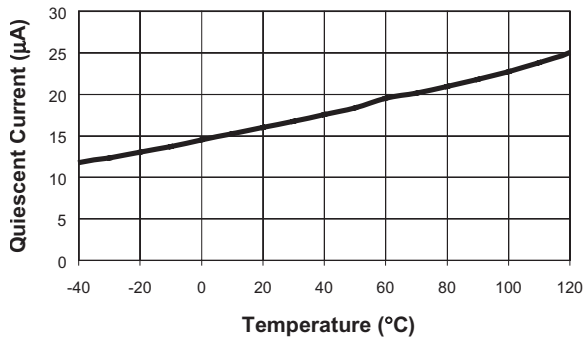

Quiescent Current

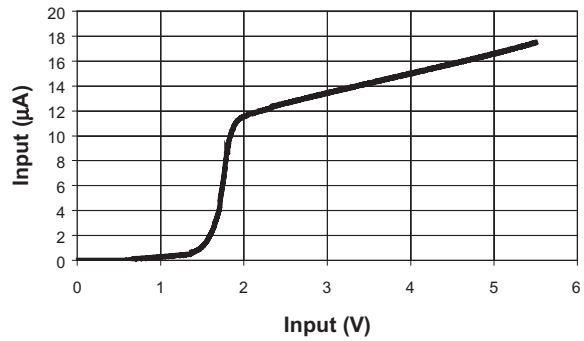

Current Limit

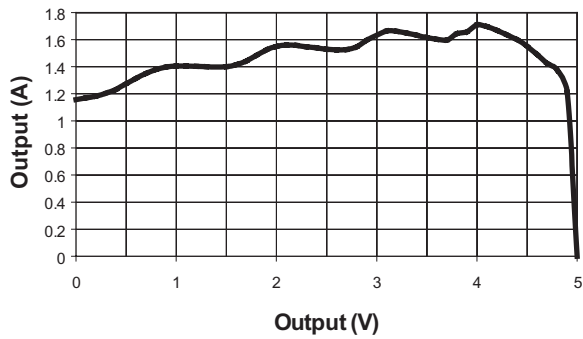

Off-Supply Current vs. Temperature

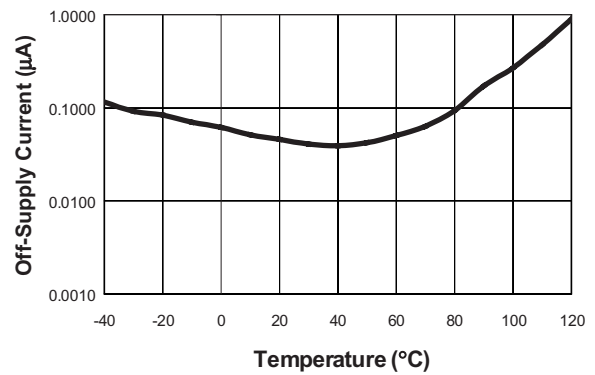

Off-Switch Current vs. Temperature

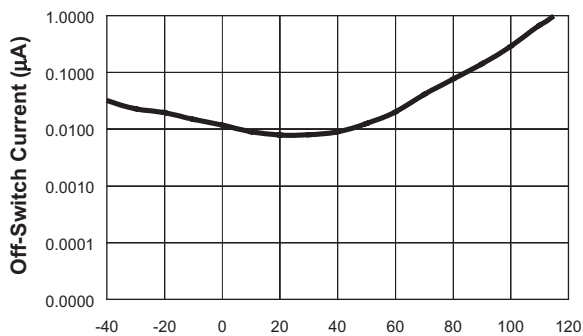

Turn-ON/OFF Response with 10 Ohm 1μF load

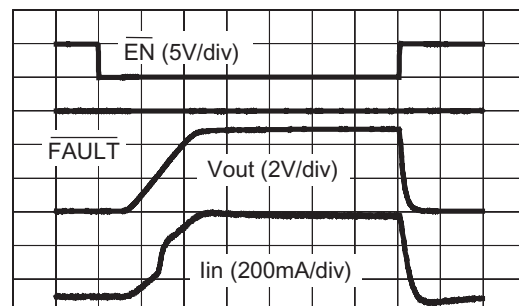

(Unless otherwise noted, $V_{IN} = 5V$, $T_A = 25^\circ C$)

Start Into 1 Ohm load

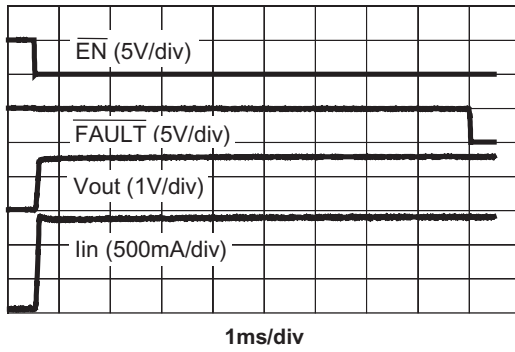

Thermal Shutdown Response

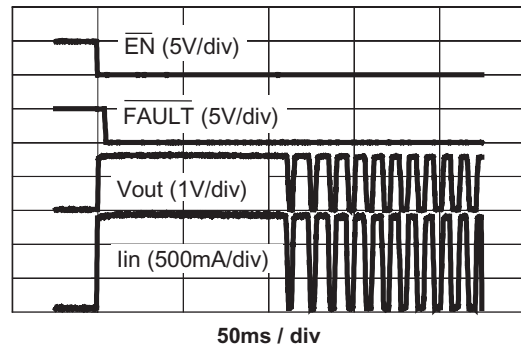

Short Circuit Through 0.3 Ohm

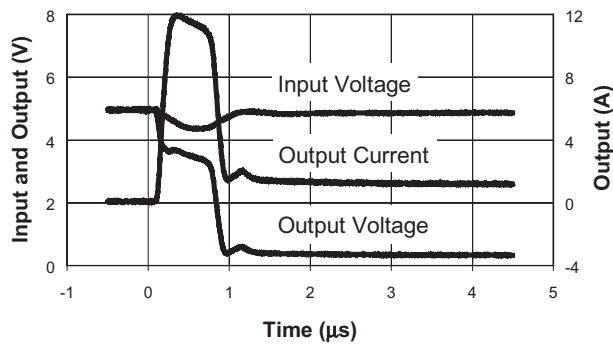

Short Circuit Through 0.6 Ohm

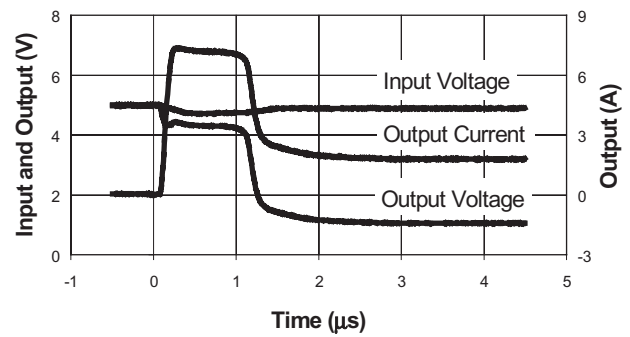

$R_{ds(ON)}$ vs. Temperature

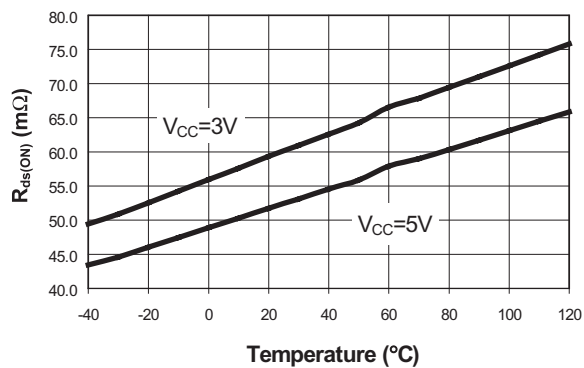

Functional Block Diagram

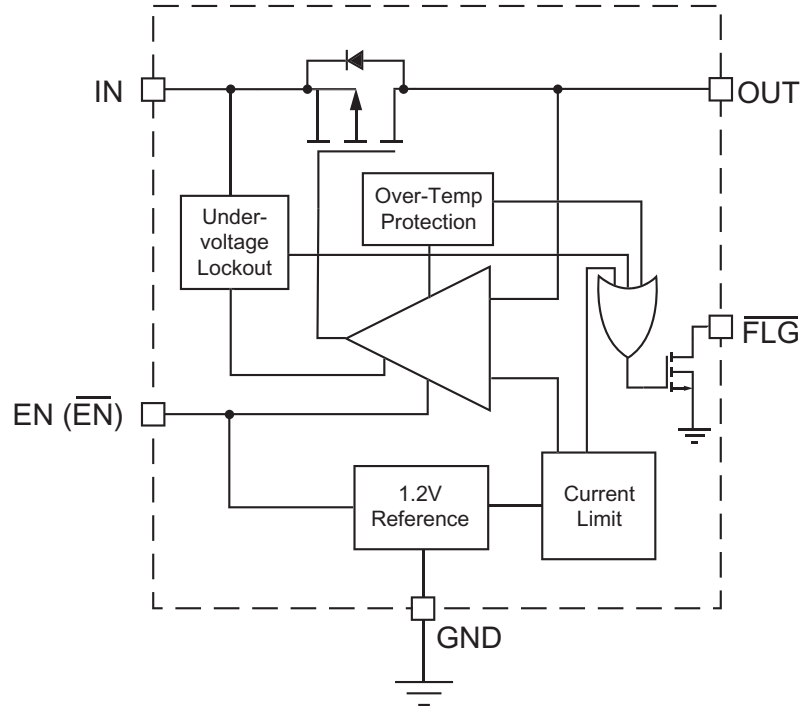

Ordering Information

| Package | Enable | Marking | Part Number | |
|---------|------------------|---------|-----------------|-----------------|
| | | | Bulk | Tape and Reel |
| SOP8 | EN (Active-high) | | AAT4625IAS-1-B1 | AAT4625IAS-1-T1 |
| SOP8 | EN (Active-low) | | AAT4625IAS-B1 | AAT4625IAS-T1 |
| TSSOP8 | EN (Active-high) | | AAT4625IHS-1-B1 | AAT4625IHS-1-T1 |
| TSSOP8 | EN (Active-low) | | AAT4625IHS-B1 | AAT4625IHS-T1 |

Package Information

SOP-8

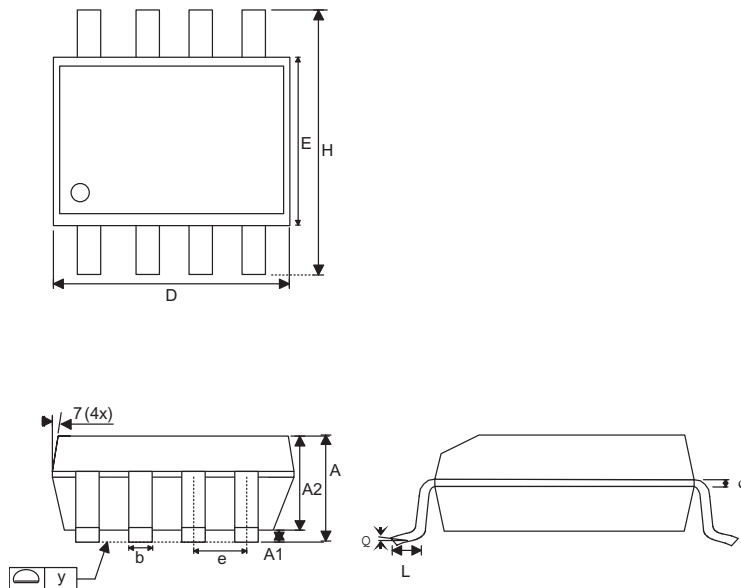

| Dim | Millimeters | | Inches | |
|-----|-------------|------|--------|-------|
| | Min | Max | Min | Max |
| A | 1.35 | 1.75 | 0.053 | 0.069 |
| A1 | 0.10 | 0.25 | 0.004 | 0.010 |
| A2 | 1.45 | | 0.057 | |
| B | 0.33 | 0.51 | 0.013 | 0.020 |
| C | 0.19 | 0.25 | 0.007 | 0.010 |
| D | 4.80 | 5.00 | 0.189 | 0.197 |
| E | 3.80 | 4.00 | 0.150 | 0.157 |
| e | 1.27 | | 0.050 | |
| H | 5.80 | 6.20 | 0.228 | 0.244 |
| L | 0.40 | 1.27 | 0.016 | 0.050 |
| Y | 0.00 | 0.10 | 0.000 | 0.004 |
| θ1 | 0° | 8° | 0° | 8° |

Note:

1. PACKAGE BODY SIZES EXCLUDE MOLD FLASH PROTRUSIONS OR GATE BURRS.
2. TOLERANCE 0.1000mm (4mil) UNLESS OTHERWISE SPECIFIED
3. COPLANARITY: 0.1000mm
4. DIMENSION L IS MEASURED IN GAGE PLANE.
5. CONTROLLING DIMENSION IS MILLIMETER; CONVERTED INCH DIMENSIONS ARE NOT NECESSARILY EXACT.

TSSOP-8

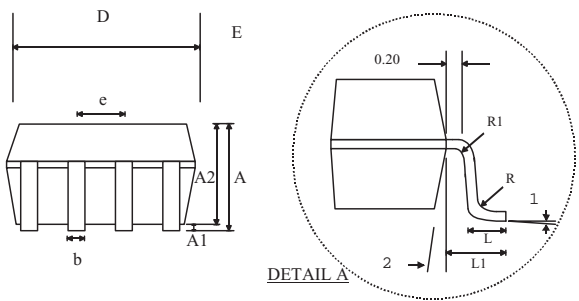
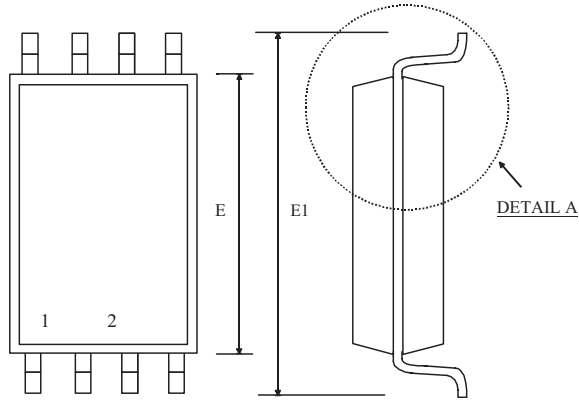

| Dim | Millimeters | | Inches | |
|------|-------------|------|-----------|-------|
| | Min | Max | Min | Max |
| A | 1.05 | 1.20 | 0.041 | 0.047 |
| A1 | 0.05 | 0.15 | 0.002 | 0.006 |
| A2 | - | 1.05 | - | 0.041 |
| b | 0.25 | 0.30 | 0.010 | 0.012 |
| c | 0.127 | | 0.005 | |
| D-8 | 2.90 | 3.10 | 0.114 | 0.122 |
| D-28 | 9.60 | 9.80 | 0.378 | 0.386 |
| E | 4.30 | 4.50 | 0.170 | 0.177 |
| E1 | 6.20 | 6.60 | 0.244 | 0.260 |
| e | 0.65 BSC | | 0.025 BSC | |
| L | 0.50 | 0.70 | 0.20 | 0.028 |
| L1 | 1.0 | | 0.039 | |
| R | 0.09 | - | 0.004 | - |
| R1 | 0.09 | - | 0.004 | - |
| θ1 | 0° | 8° | 0° | 8° |
| θ2 | 12° | | | |