

# 1.1A Step-Up DC/DC Converter in ThinSOT™ with Integrated Soft-Start

## FEATURES

- **1.3MHz Switching Frequency (LT3467)**
- **2.1MHz Switching Frequency (LT3467A)**
- **Low  $V_{CESAT}$  Switch: 330mV at 1.1A**
- **High Output Voltage: Up to 40V**
- **Wide Input Range: 2.4V to 16V**
- **Dedicated Soft-Start Pin**
- 5V at 540mA from 3.3V Input (LT3467)
- 5V at 430mA from 3.3V Input (LT3467A)
- 12V at 270mA from 5V Input (LT3467)
- 12V at 260mA from 5V Input (LT3467A)
- Uses Small Surface Mount Components
- Low Shutdown Current:  $< 1\mu\text{A}$
- Pin-for-Pin Compatible with the LT1930 and LT1613
- Low Profile (1mm) SOT-23 Package

## APPLICATIONS

- Digital Cameras
- White LED Power Supplies
- Cellular Phones
- Medical Diagnostic Equipment
- Local 5V or 12V Supplies
- TFT-LCD Bias Supplies
- xDSL Power Supplies

## DESCRIPTION

The LT<sup>®</sup>3467/LT3467A SOT-23 switching regulators combine a 42V, 1.1A switch with a soft-start function. Pin compatible with the LT1930, its low  $V_{CESAT}$  bipolar switch enables the device to deliver high current outputs in a small footprint. The LT3467 switches at 1.3MHz, allowing the use of tiny, low cost and low height inductors and capacitors. The LT3467A switches at 2.1MHz, allowing the use of even smaller components. High inrush current at start-up is eliminated using the programmable soft-start function. A single external capacitor sets the current ramp rate. A constant frequency current mode PWM architecture results in low, predictable output noise that is easy to filter.

The high voltage switch on the LT3467/LT3467A is rated at 42V, making the devices ideal for boost converters up to 40V as well as SEPIC and flyback designs. The LT3467 can generate 5V at up to 540mA from a 3.3V supply or 5V at 450mA from four alkaline cells in a SEPIC design. The LT3467A can generate 5V at up to 430mA from a 3.3V supply or 15V at 135mA from a 3.3V supply. The LT3467/LT3467A are available in a low profile (1mm) 6-lead SOT-23 package.

LT, LTC and LT are registered trademarks of Linear Technology Corporation  
 ThinSOT is a trademark of Linear Technology Corporation.

## TYPICAL APPLICATION

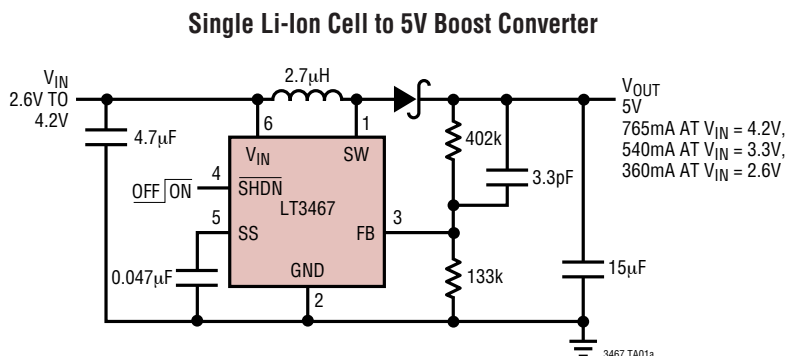

**Efficiency**

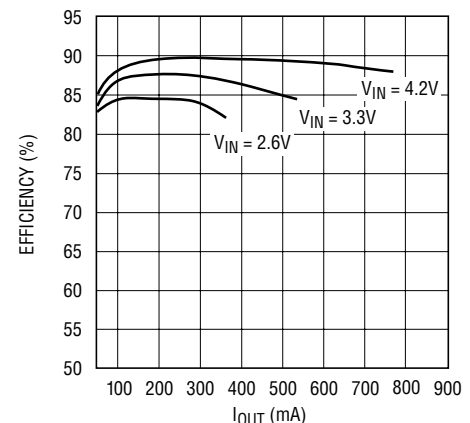

3467 TA01b

sn3467 3467afs

# LT3467/LT3467A

## ABSOLUTE MAXIMUM RATINGS

(Note 1)

$V_{IN}$ Voltage .....	16V
SW Voltage .....	-0.4V to 42V
FB Voltage .....	2.5V
Current Into FB Pin .....	$\pm 1$ mA
SHDN Voltage .....	16V
Maximum Junction Temperature .....	125°C
Operating Temperature Range (Note 2) ..	-40°C to 85°C
Storage Temperature Range .....	-65°C to 150°C
Lead Temperature (Soldering, 10 sec) .....	300°C

## PACKAGE/ORDER INFORMATION

	ORDER PART NUMBER
	LT3467ES6 LT3467AES6
	S6 PART MARKING
	LTACH LTBCC

Consult LTC Marketing for parts specified with wider operating temperature ranges.

## ELECTRICAL CHARACTERISTICS

The ● denotes specifications which apply over the full operating temperature range, otherwise specifications are  $T_A = 25^\circ\text{C}$ .  $V_{IN} = 3\text{V}$ ,  $V_{SHDN} = V_{IN}$  unless otherwise noted. Specifications are for both the LT3467 and LT3467A unless otherwise noted.

PARAMETER	CONDITIONS	MIN	TYP	MAX	UNITS
Minimum Operating Voltage			2.2	2.4	V
Maximum Operating Voltage				16	V
Feedback Voltage		1.230	1.255	1.270	V
		● 1.220		1.280	V
FB Pin Bias Current	(Note 3)	●	10	50	nA
Quiescent Current	$V_{SHDN} = 2.4\text{V}$ , Not Switching		1.2	2	mA
Quiescent Current in Shutdown	$V_{SHDN} = 0.5\text{V}$ , $V_{IN} = 3\text{V}$		0.01	1	$\mu\text{A}$
Reference Line Regulation	$2.6\text{V} \leq V_{IN} \leq 16\text{V}$		0.01	0.05	%/V
Switching Frequency	LT3467	1	1.3	1.6	MHz
	LT3467A	1.6	2.1	2.7	MHz
	LT3467A	● 1.6			MHz
Maximum Duty Cycle	LT3467	88	94		%
	LT3467	● 87			%
	LT3467A	82	88		%
	LT3467A	● 78			%
Minimum Duty Cycle			10		%
Switch Current Limit	At Minimum Duty Cycle	1.4	1.8	2.5	A
	At Maximum Duty Cycle (Note 4)	0.8	1.2	1.9	A
Switch $V_{CESAT}$	$I_{SW} = 1.1\text{A}$		330	500	mV
Switch Leakage Current	$V_{SW} = 5\text{V}$		0.01	1	$\mu\text{A}$
SHDN Input Voltage High		2.4			V
SHDN Input Voltage Low				0.5	V
SHDN Pin Bias Current	$V_{SHDN} = 3\text{V}$		16	32	$\mu\text{A}$
	$V_{SHDN} = 0\text{V}$		0	0.1	$\mu\text{A}$
SS Charging Current	$V_{SS} = 0.5\text{V}$	2	3	4.5	$\mu\text{A}$

**Note 1:** Absolute Maximum Ratings are those values beyond which the life of a device may be impaired.

**Note 2:** The LT3467E/LT3467AE are guaranteed to meet performance specifications from 0°C to 70°C. Specifications over the -40°C to 85°C operating temperature range are assured by design, characterization and correlation with statistical process controls.

**Note 3:** Current flows out of the pin.

**Note 4:** See Typical Performance Characteristics for guaranteed current limit vs duty cycle.

sn3467 3467afs

# TYPICAL PERFORMANCE CHARACTERISTICS

**Quiescent Current vs Temperature**

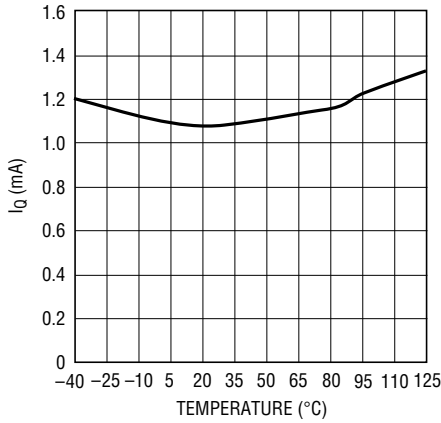

3467 G01

**FB Pin Voltage vs Temperature**

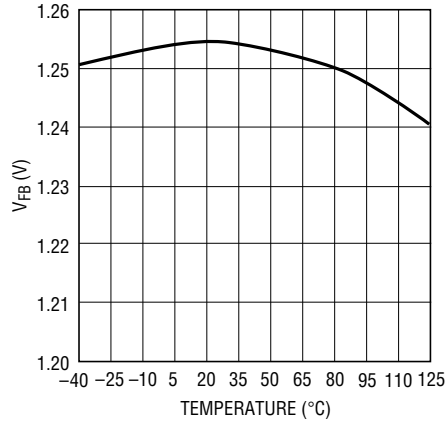

3467 G02

**SHDN Current vs SHDN Voltage**

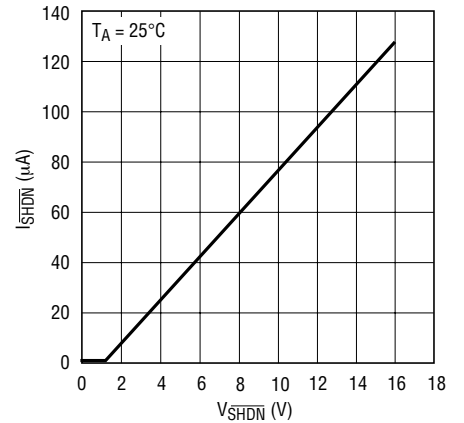

3467 G03

**Current Limit vs Duty Cycle**

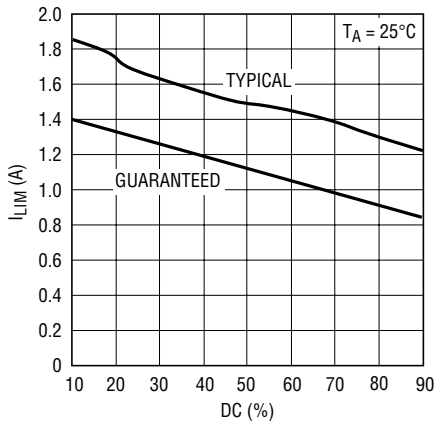

3467 G04

**Switch Saturation Voltage vs Switch Current**

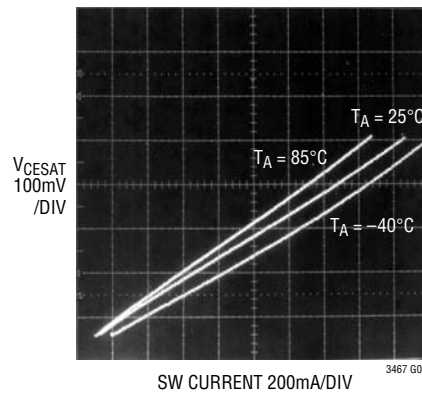

3467 G05

**Oscillator Frequency vs Temperature**

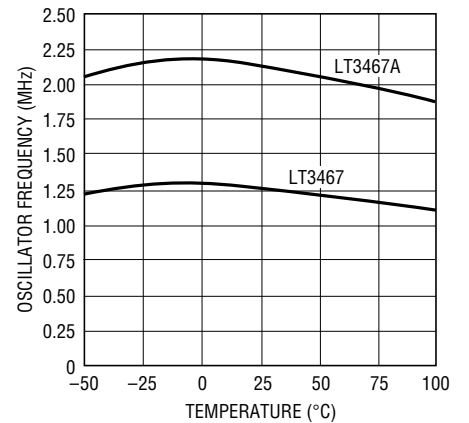

3467 G06

**Soft-Start Current vs Soft-Start Voltage**

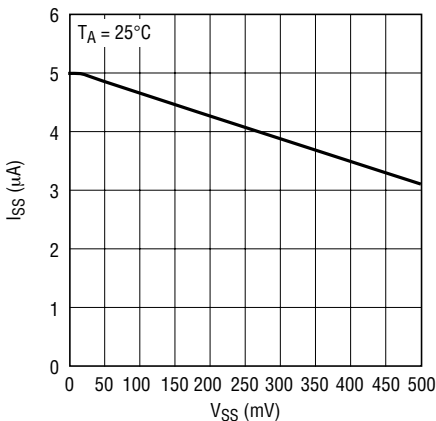

3467 G07

**Peak Switch Current vs Soft-Start Voltage**

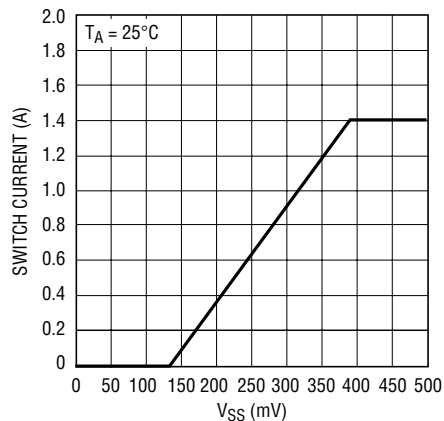

3467 G08

**Start-Up Waveform (Figure 2 Circuit)**

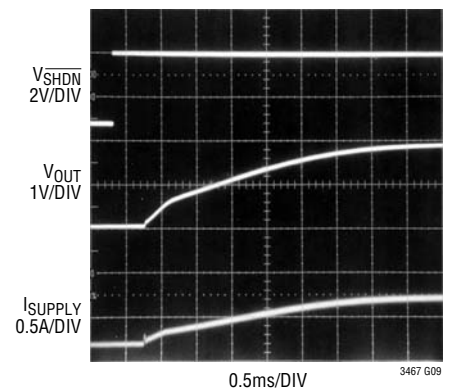

3467 G09

## PIN FUNCTIONS

**SW (Pin 1):** Switch Pin. (Collector of internal NPN power switch) Connect inductor/diode here and minimize the metal trace area connected to this pin to minimize EMI.

**GND (Pin 2):** Ground. Tie directly to local ground plane.

**FB (Pin 3):** Feedback Pin. Reference voltage is 1.255V. Connect resistive divider tap here. Minimize trace area at FB. Set  $V_{OUT} = 1.255V(1 + R1/R2)$ .

**SHDN (Pin 4):** Shutdown Pin. Tie to 2.4V or more to enable device. Ground to shut down.

**SS (Pin 5):** Soft-Start Pin. Place a soft-start capacitor here. Upon start-up, 4 $\mu$ A of current charges the capacitor to 1.255V. Use a larger capacitor for slower start-up. Leave floating if not in use.

**V<sub>IN</sub> (Pin 6):** Input Supply Pin. Must be locally bypassed.

## BLOCK DIAGRAM

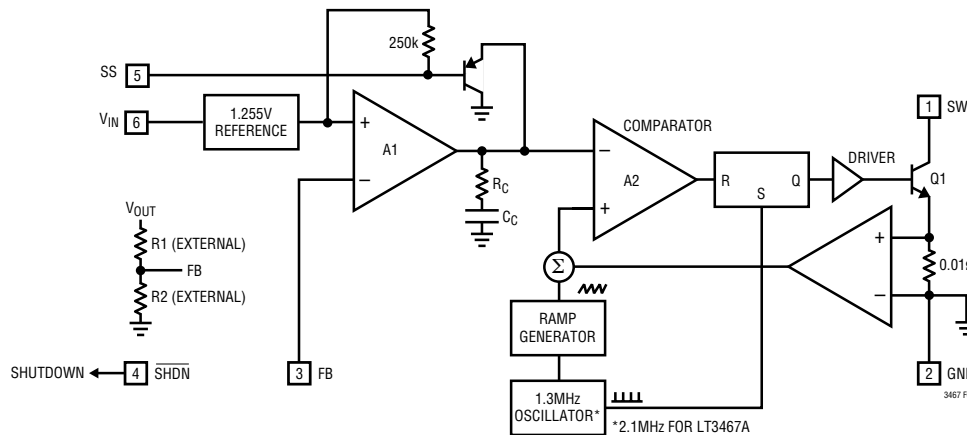

Figure 1. Block Diagram

## OPERATION

The LT3467 uses a constant frequency, current-mode control scheme to provide excellent line and load regulation. Refer to the Block Diagram above. At the start of each oscillator cycle, the SR latch is set which turns on the power switch Q1. A voltage proportional to the switch current is added to a stabilizing ramp and the resulting sum is fed into the positive terminal of the PWM comparator A2. When this voltage exceeds the level at the negative input of A2, the SR latch is reset, turning off the power switch. The level at the negative input of A2 is set by the error amplifier A1, and is simply an amplified version of the difference between the feedback voltage and the reference voltage of 1.255V. In this manner, the error amplifier sets the correct peak current level to keep the output in regulation. If the error amplifier's output increases, more current is delivered to the output. Similarly, if the error decreases, less current is delivered. The soft-start feature

of the LT3467 allows for clean start-up conditions by limiting the rate of voltage rise at the output of comparator A1 which, in turn, limits the peak switch current. The soft-start pin is connected to a reference voltage of 1.255V through a 250k resistor, providing 4 $\mu$ A of current to charge the soft-start capacitor. Typical values for the soft-start capacitor range from 10nF to 200nF. The LT3467 has a current limit circuit not shown in the Block Diagram. The switch current is constantly monitored and not allowed to exceed the maximum switch current (typically 1.4A). If the switch current reaches this value, the SR latch is reset regardless of the state of comparator A2. This current limit protects the power switch as well as the external components connected to the LT3467.

The Block Diagram for the LT3467A (not shown) is identical except that the oscillator frequency is 2.1MHz.

## APPLICATIONS INFORMATION

### Duty Cycle

The typical maximum duty cycle of the LT3467 is 94% (88% for the LT3467A). The duty cycle for a given application is given by:

$$DC = \frac{|V_{OUT}| + |V_D| - |V_{IN}|}{|V_{OUT}| + |V_D| - |V_{CESAT}|}$$

Where  $V_D$  is the diode forward voltage drop and  $V_{CESAT}$  is in the worst case 330mV (at 1.1A)

The LT3467 and LT3467A can be used at higher duty cycles, but must be operated in the discontinuous conduction mode so that the actual duty cycle is reduced.

### Setting Output Voltage

R1 and R2 determine the output voltage.

$$V_{OUT} = 1.255V (1 + R1/R2)$$

### Switching Frequency and Inductor Selection

The LT3467 switches at 1.3 MHz, allowing for small valued inductors to be used. 4.7µH or 10µH will usually suffice. The LT3467A switches at 2.1MHz, allowing for even smaller valued inductors to be used. 0.9µH to 6.8µH will usually suffice. Choose an inductor that can handle at least 1.2A without saturating, and ensure that the inductor has a low DCR (copper-wire resistance) to minimize  $I^2R$  power losses. Note that in some applications, the current handling requirements of the inductor can be lower, such as in the SEPIC topology where each inductor only carries one half of the total switch current. For better efficiency, use similar valued inductors with a larger volume. Many different sizes and shapes are available from various manufacturers. Choose a core material that has low losses at 1.3 MHz, (2.1MHz for the LT3467A) such as ferrite core.

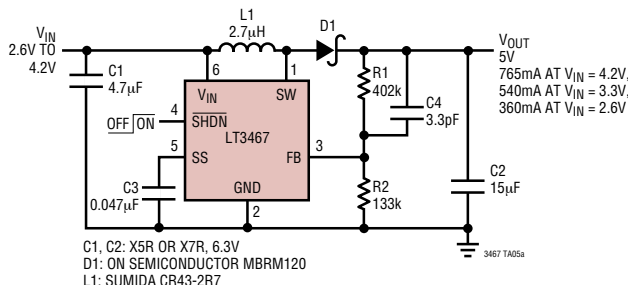

Figure 2. Single Li-Ion Cell to 5V Boost Converter (Same as 1st Page Application)

Table 1. Inductor Manufacturers.

Sumida	(847) 956-0666	www.sumida.com
TDK	(847) 803-6100	www.tdk.com
Murata	(714) 852-2001	www.murata.com
FDK	(408) 432-8331	www.fdk.co.jp

### Soft-Start

The soft-start feature provides a way to limit the inrush current drawn from the supply upon startup. An internal 250k resistor charges the external soft start capacitor to 1.255V. After the capacitor reaches 0.15V the rate of voltage rise at the output of the comparator A1 tracks the rate of voltage rise of the soft-start capacitor. This limits the inrush current drawn from the supply during startup. Once the part is shut down, the soft start capacitor is quickly discharged to 0.4V, then slowly discharged through the 250k resistor to ground. If the part is to be shut down and re-enabled in a short period of time while soft-start is used, you must ensure that the soft-start capacitor has enough time to discharge before re-enabling the part. Typical values of the soft-start capacitor range from 10nF to 200nF.

Supply Current of Figure 2 During Startup without Soft-Start Capacitor

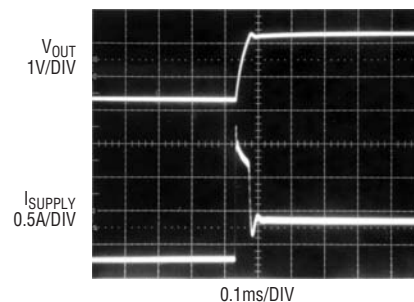

Supply Current of Figure 2 During Startup with 47nF Soft-Start Capacitor

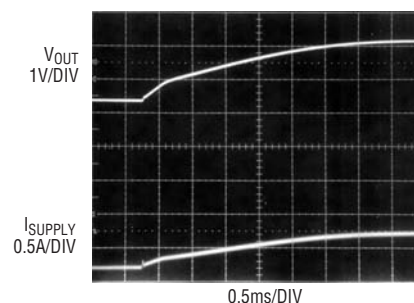



## APPLICATIONS INFORMATION

### CAPACITOR SELECTION

Low ESR (equivalent series resistance) capacitors should be used at the output to minimize the output ripple voltage. Multi-layer ceramic capacitors are an excellent choice, as they have extremely low ESR and are available in very small packages. X5R dielectrics are preferred, followed by X7R, as these materials retain the capacitance over wide voltage and temperature ranges. A 4.7µF to 15µF output capacitor is sufficient for most applications, but systems with very low output currents may need only a 1µF or 2.2µF output capacitor. Solid tantalum or OSCON capacitors can be used, but they will occupy more board area than a ceramic and will have a higher ESR. Always use a capacitor with a sufficient voltage rating.

Ceramic capacitors also make a good choice for the input decoupling capacitor, which should be placed as close as possible to the LT3467. A 1µF to 4.7µF input capacitor is sufficient for most applications. Table 2 shows a list of several ceramic capacitor manufacturers. Consult the manufacturers for detailed information on their entire selection of ceramic parts.

**Table 2. Ceramic Capacitor Manufacturers**

Taiyo Yuden	(408) 573-4150	www.t-yuden.com
AVX	(803) 448-9411	www.avxcorp.com
Murata	(714) 852-2001	www.murata.com

The decision to use either low ESR (ceramic) capacitors or the higher ESR (tantalum or OSCON) capacitors can affect the stability of the overall system. The ESR of any capacitor, along with the capacitance itself, contributes a zero to the system. For the tantalum and OSCON capacitors, this zero is located at a lower frequency due to the higher value of the ESR, while the zero of a ceramic capacitor is at a much higher frequency and can generally be ignored.

A phase lead zero can be intentionally introduced by placing a capacitor (C4) in parallel with the resistor (R1) between V<sub>OUT</sub> and V<sub>FB</sub> as shown in Figure 2. The frequency of the zero is determined by the following equation.

$$f_z = \frac{1}{2\pi \cdot R1 \cdot C4}$$

By choosing the appropriate values for the resistor and capacitor, the zero frequency can be designed to improve

the phase margin of the overall converter. The typical target value for the zero frequency is between 35kHz to 55kHz. Figure 3 shows the transient response of the step-up converter from Figure 8 without the phase lead capacitor C4. Although adequate for many applications, phase margin is not ideal as evidenced by 2-3 “bumps” in both the output voltage and inductor current. A 22pF capacitor for C4 results in ideal phase margin, which is revealed in Figure 4 as a more damped response and less overshoot.

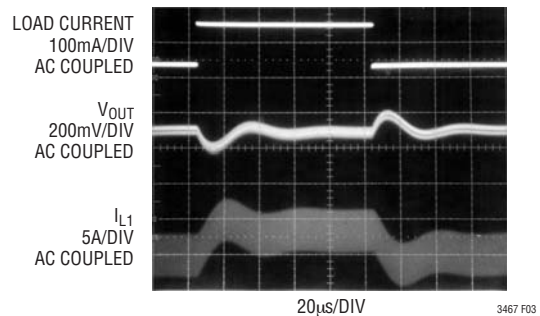

**Figure 3. Transient Response of Figure 8's Step-Up Converter without Phase Lead Capacitor**

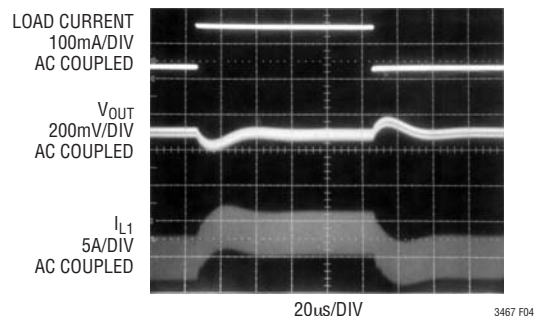

**Figure 4. Transient Response of Figure 8's Step-Up Converter with 22pF Phase Lead Capacitor**

### DIODE SELECTION

A Schottky diode is recommended for use with the LT3467 and the LT3467A. The Philips PMEG 2005 is a very good choice. Where the switch voltage exceeds 20V, use the PMEG 3005 (a 30V diode). Where the switch voltage exceeds 30V, use the PMEG 4005 (a 40V diode). These diodes are rated to handle an average forward current of 0.5A. In applications where the average forward current of the diode exceeds 0.5A, a Philips PMEG 2010 rated at 1A is recommended. For higher efficiency, use a diode with better thermal characteristics such as the On Semiconductor MBRM120 (a 20V diode) or the MBRM140 (a 40V diode).

sn3467 3467afs

## APPLICATIONS INFORMATION

### SETTING OUTPUT VOLTAGE

To set the output voltage, select the values of R1 and R2 (see Figure 2) according to the following equation.

$$R1 = R2 \left( \frac{V_{OUT}}{1.255V} - 1 \right)$$

A good value for R2 is 13.3k which sets the current in the resistor divider chain to  $1.255V/13.3k = 94\mu A$ .

### LAYOUT HINTS

The high speed operation of the LT3467/LT3467A demands careful attention to board layout. You will not get advertised performance with careless layout. Figure 5 shows the recommended component placement.

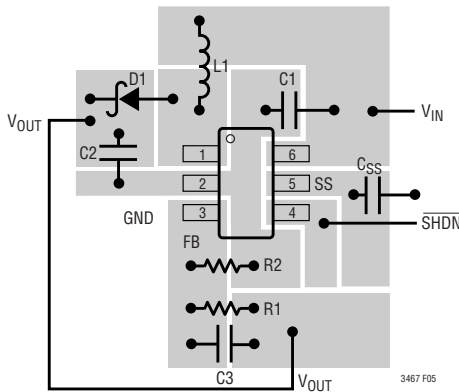

Figure 5. Suggested Layout

### Compensation—Theory

Like all other current mode switching regulators, the LT3467/LT3467A needs to be compensated for stable and efficient operation. Two feedback loops are used in the LT3467/LT3467A: a fast current loop which does not require compensation, and a slower voltage loop which does. Standard Bode plot analysis can be used to understand and adjust the voltage feedback loop.

As with any feedback loop, identifying the gain and phase contribution of the various elements in the loop is critical. Figure 6 shows the key equivalent elements of a boost converter. Because of the fast current control loop, the power stage of the IC, inductor and diode have been replaced by the equivalent transconductance amplifier

$g_{mp} \cdot g_{ma}$  acts as a current source where the output current is proportional to the  $V_C$  voltage. Note that the maximum output current of  $g_{mp}$  is finite due to the current limit in the IC.

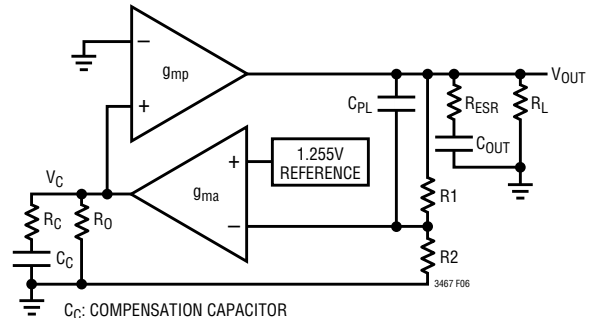

- C<sub>C</sub>: COMPENSATION CAPACITOR
- C<sub>OUT</sub>: OUTPUT CAPACITOR
- C<sub>PL</sub>: PHASE LEAD CAPACITOR
- g<sub>ma</sub>: TRANSCONDUCTANCE AMPLIFIER INSIDE IC
- g<sub>mp</sub>: POWER STAGE TRANSCONDUCTANCE AMPLIFIER
- R<sub>C</sub>: COMPENSATION RESISTOR
- R<sub>L</sub>: OUTPUT RESISTANCE DEFINED AS V<sub>OUT</sub> DIVIDED BY I<sub>LOAD</sub>(MAX)
- R<sub>O</sub>: OUTPUT RESISTANCE OF g<sub>ma</sub>
- R1, R2: FEEDBACK RESISTOR DIVIDER NETWORK
- R<sub>ESR</sub>: OUTPUT CAPACITOR ESR

Figure 6. Boost Converter Equivalent Model

From Figure 6, the DC gain, poles and zeroes can be calculated as follows:

$$\text{Output Pole: } P1 = \frac{2}{2 \cdot \pi \cdot R_L \cdot C_{OUT}}$$

$$\text{Error Amp Pole: } P2 = \frac{1}{2 \cdot \pi \cdot R_O \cdot C_C}$$

$$\text{Error Amp Zero: } Z1 = \frac{1}{2 \cdot \pi \cdot R_C \cdot C_C}$$

$$\text{DC GAIN: } A = \frac{1.255}{V_{OUT}} \cdot g_{ma} \cdot R_O \cdot g_{mp} \cdot R_L \cdot \frac{1}{2}$$

$$\text{ESR Zero: } Z2 = \frac{1}{2 \cdot \pi \cdot R_{ESR} \cdot C_{OUT}}$$

$$\text{RHP Zero: } Z3 = \frac{V_{IN}^2 \cdot R_L}{2 \cdot \pi \cdot V_{OUT}^2 \cdot L}$$

$$\text{High Frequency Pole: } P3 > \frac{f_S}{3}$$

$$\text{Phase Lead Zero: } Z4 = \frac{1}{2 \cdot \pi \cdot R1 \cdot C_{PL}}$$

$$\text{Phase Lead Pole: } P4 = \frac{1}{2 \cdot \pi \cdot C_{PL} \cdot \frac{R1 \cdot R2}{R1 + R2}}$$

sn3467 3467afs

## APPLICATIONS INFORMATION

The Current Mode zero is a right half plane zero which can be an issue in feedback control design, but is manageable with proper external component selection.

Using the circuit of Figure 2 as an example, the following table shows the parameters used to generate the Bode plot shown in Figure 7.

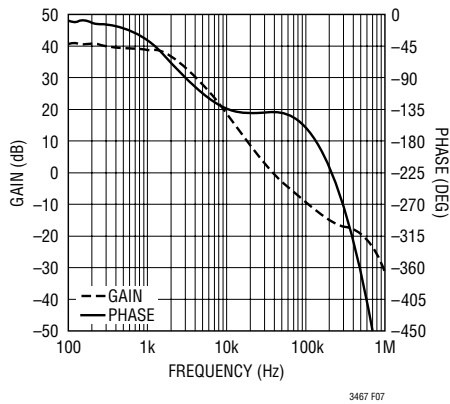

Figure 7. Bode Plot of 3.3V to 5V Application

Table 3. Bode Plot Parameters

Parameter	Value	Units	Comment
$R_L$	10.4	$\Omega$	Application Specific
$C_{OUT}$	15	$\mu F$	Application Specific
$R_{ESR}$	10	$m\Omega$	Application Specific
$R_O$	0.4	$M\Omega$	Not Adjustable
$C_C$	60	$pF$	Not Adjustable
$C_{PL}$	3.3	$pF$	Adjustable
$R_C$	100	$k\Omega$	Not Adjustable
$R_1$	402	$k\Omega$	Adjustable
$R_2$	133	$k\Omega$	Adjustable
$V_{OUT}$	5	V	Application Specific
$V_{IN}$	3.3	V	Application Specific
$g_{ma}$	35	$\mu mho$	Not Adjustable
$g_{mp}$	7.5	$mho$	Not Adjustable
$L$	2.7	$\mu H$	Application Specific
$f_S$	1.3*	MHz	Not Adjustable

\*2.1MHz for LT3467A

From Figure 7, the phase is  $-138^\circ$  when the gain reaches 0dB giving a phase margin of  $42^\circ$ . This is more than adequate. The crossover frequency is 37kHz.

## TYPICAL APPLICATIONS

### Lithium-Ion to 6V Step-Up DC/DC Converter

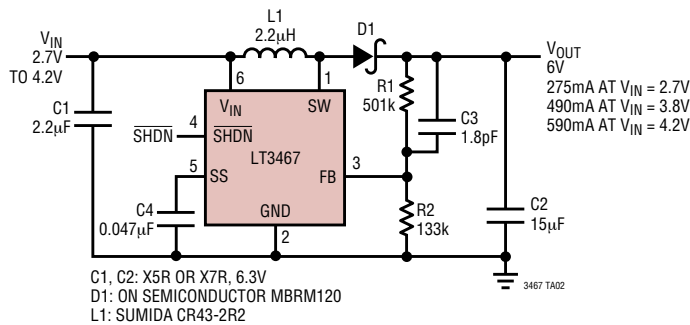

### Li-Ion to 6V

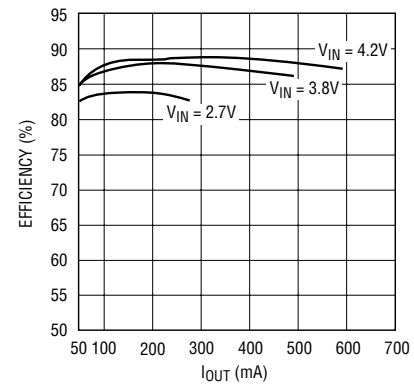

### 4-Cell to 5V SEPIC Converter

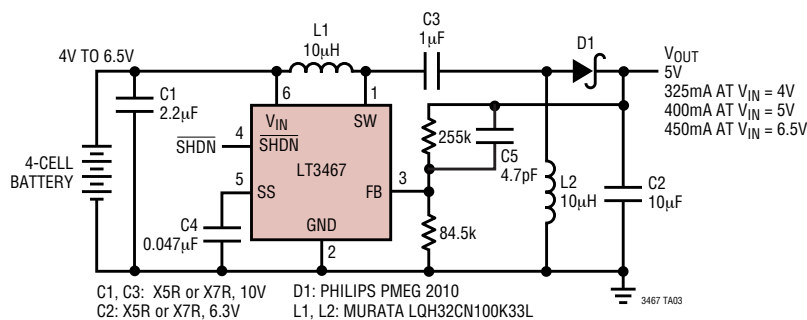



# TYPICAL APPLICATIONS

5V to 40V Boost Converter

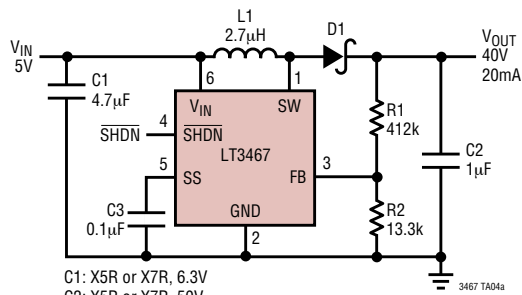

- C1: X5R or X7R, 6.3V
- C2: X5R or X7R, 50V
- D1: ON SEMICONDUCTOR, MBRM140
- L1: SUMIDA CD43-2R7

±15V Dual Output Converter with Output Disconnect

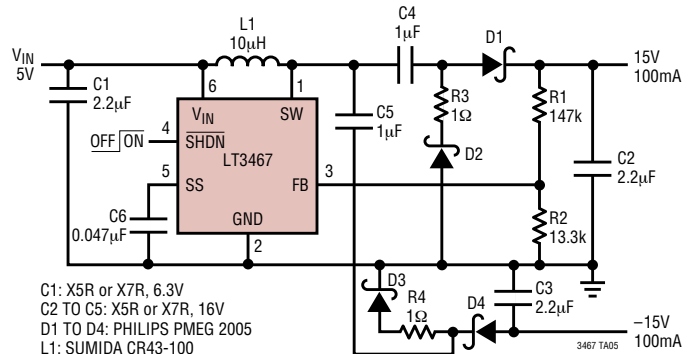

- C1: X5R or X7R, 6.3V
- C2 TO C5: X5R or X7R, 16V
- D1 TO D4: PHILIPS PMEG 2005
- L1: SUMIDA CR43-100

9V, 18V, -9V Triple Output TFT-LCD Bias Supply with Soft-Start

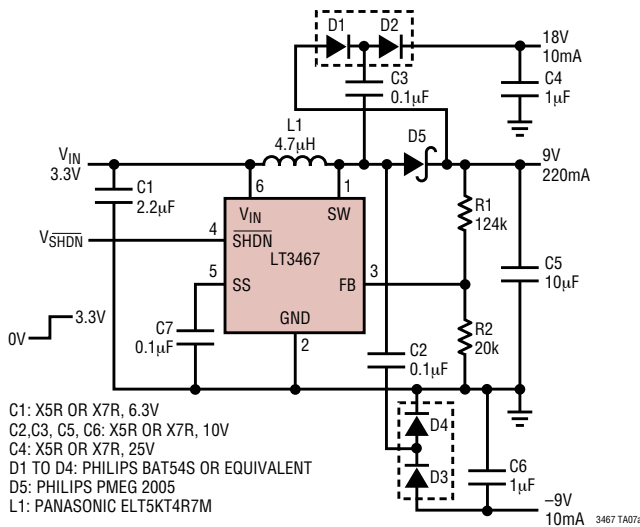

- C1: X5R OR X7R, 6.3V
- C2, C3, C5, C6: X5R OR X7R, 10V
- C4: X5R OR X7R, 25V
- D1 TO D4: PHILIPS BAT54S OR EQUIVALENT
- D5: PHILIPS PMEG 2005
- L1: PANASONIC ELT5KT4R7M

Start-Up Waveforms

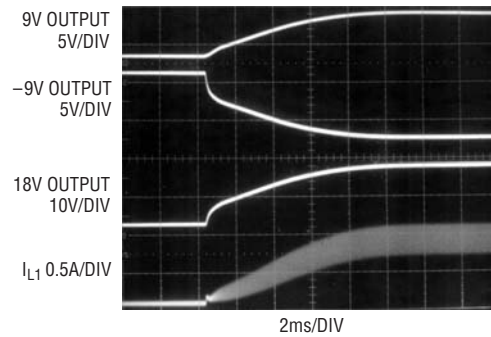

8V, 23V, -8V Triple Output TFT-LCD Bias Supply with Soft-Start

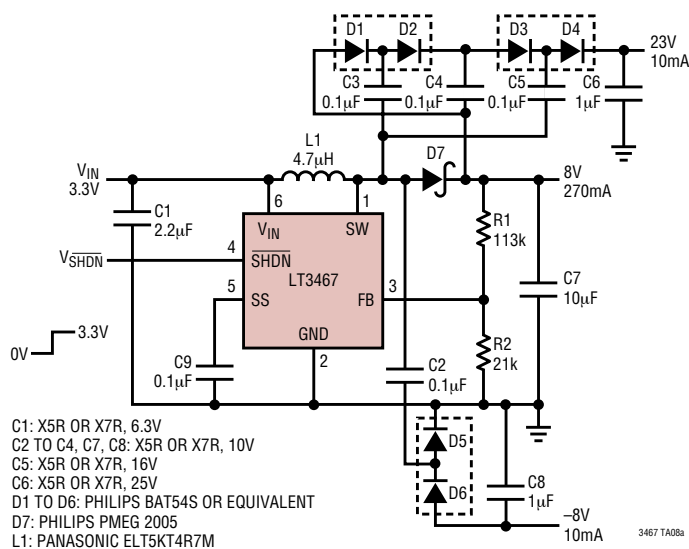

- C1: X5R OR X7R, 6.3V
- C2 TO C4, C7, C8: X5R OR X7R, 10V
- C5: X5R OR X7R, 16V
- C6: X5R OR X7R, 25V
- D1 TO D6: PHILIPS BAT54S OR EQUIVALENT
- D7: PHILIPS PMEG 2005
- L1: PANASONIC ELT5KT4R7M

Start-Up Waveforms

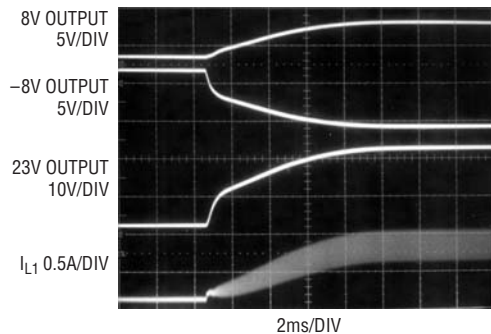

## TYPICAL APPLICATIONS

### 2.6V – 3.3V to 5V Boost Converter

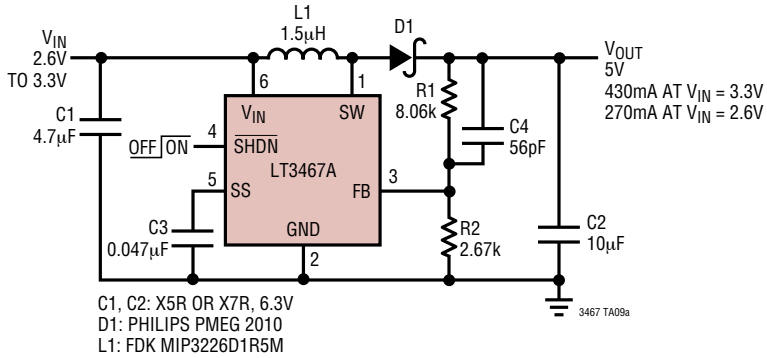

### Efficiency

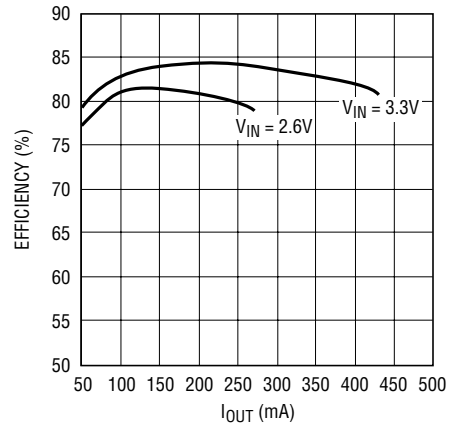

3467 TA08b

### Single Li-Ion Cell to 5V Boost Converter

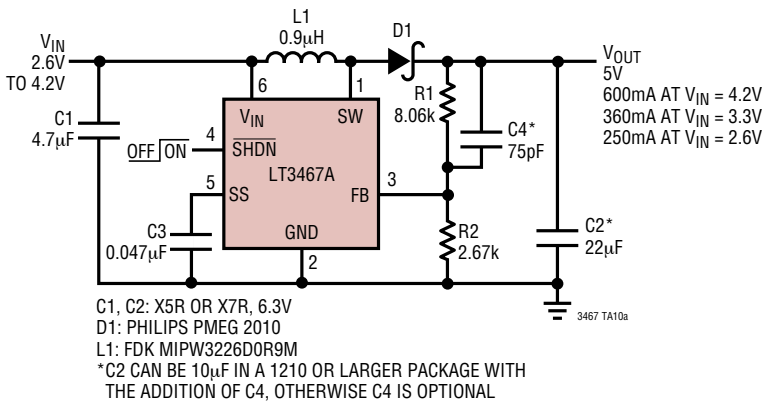

### Efficiency

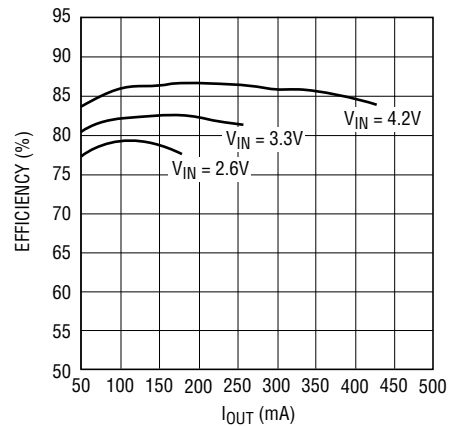

3467 TA09b

### 3.3V to 15V, 135mA Step-Up Converter

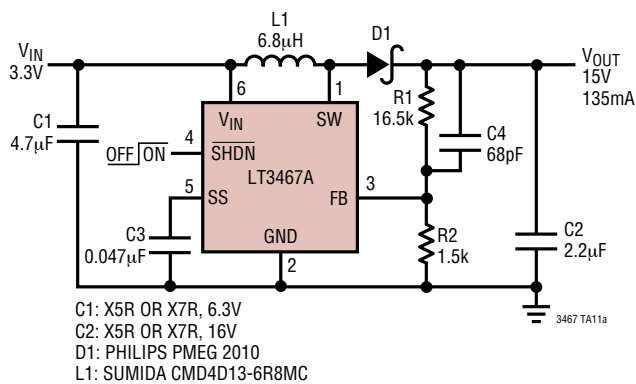

### Efficiency

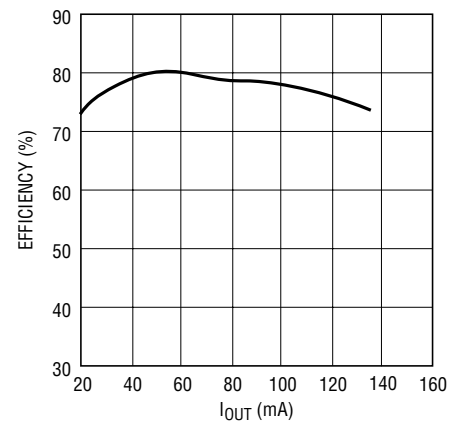

3467 TA10b

# PACKAGE DESCRIPTION

**S6 Package**  
**6-Lead Plastic TSOT-23**  
 (Reference LTC DWG # 05-08-1636)

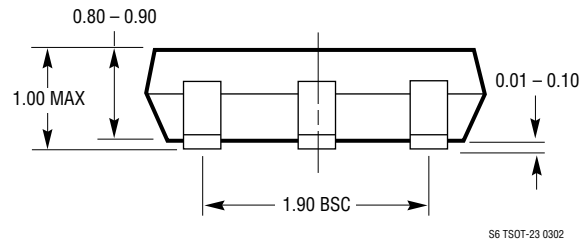
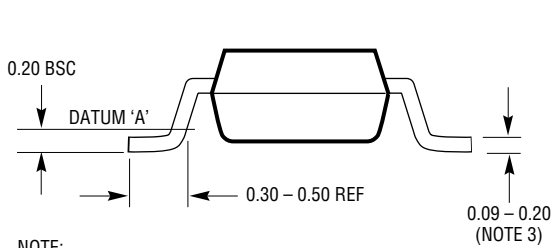
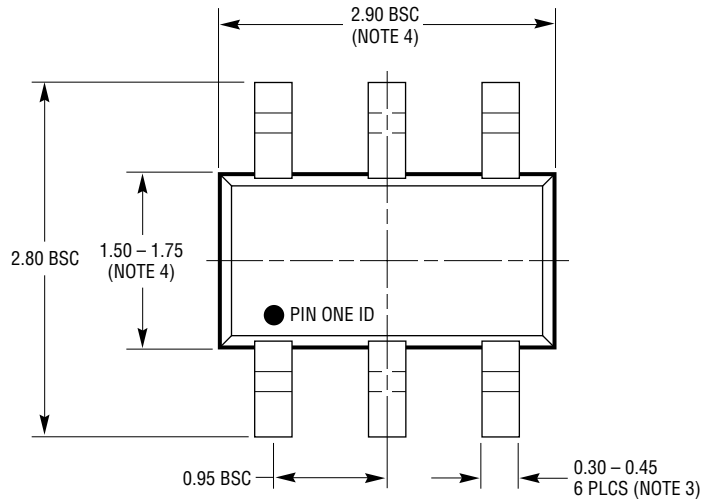
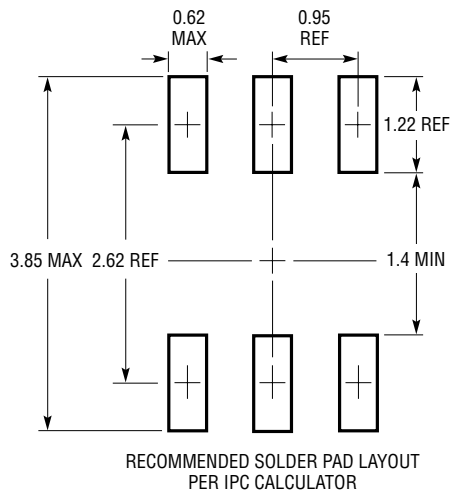

- NOTE:
1. DIMENSIONS ARE IN MILLIMETERS
  2. DRAWING NOT TO SCALE
  3. DIMENSIONS ARE INCLUSIVE OF PLATING
  4. DIMENSIONS ARE EXCLUSIVE OF MOLD FLASH AND METAL BURR
  5. MOLD FLASH SHALL NOT EXCEED 0.254mm
  6. JEDEC PACKAGE REFERENCE IS MO-193

## TYPICAL APPLICATIONS

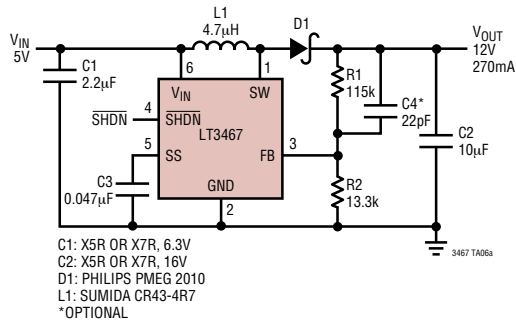

Figure 8. 5V to 12V, 270mA Step-Up Converter

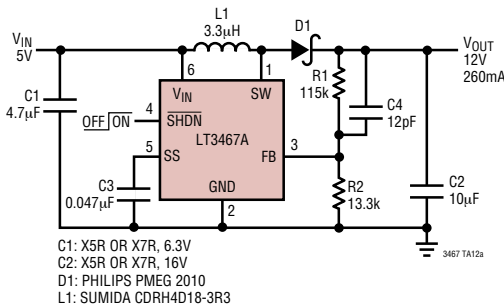
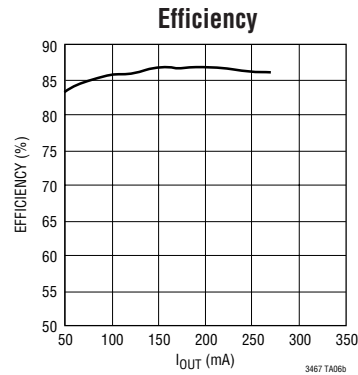
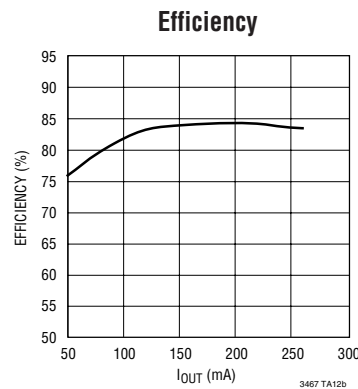

Figure 9. 5V to 12V, 260mA Step-Up Converter



## RELATED PARTS

PART NUMBER	DESCRIPTION	COMMENTS
LT1615/LT1615-1	300mA/80mA (I <sub>SW</sub> ), High Efficiency Step-Up DC/DC Converter	V <sub>IN</sub> : 1V to 15V, V <sub>OUT(MAX)</sub> = 34V, I <sub>Q</sub> = 20µA, I <sub>SD</sub> < 1µA, ThinSOT Package
LT1618	1.5A (I <sub>SW</sub> ), 1.25MHz, High Efficiency Step-Up DC/DC Converter	90% Efficiency, V <sub>IN</sub> : 1.6V to 18V, V <sub>OUT(MAX)</sub> = 35V, I <sub>Q</sub> = 1.8mA, I <sub>SD</sub> < 1µA, MS Package
LTC1700	No R <sub>SENSE</sub> <sup>™</sup> , 530kHz, Synchronous Step-Up DC/DC Controller	95% Efficiency, V <sub>IN</sub> : 0.9V to 5V, I <sub>Q</sub> = 200µA, I <sub>SD</sub> < 10µA, MS Package
LTC1871	Wide Input Range, 1MHz, No R <sub>SENSE</sub> Current Mode Boost, Flyback and SEPIC Controller	92% Efficiency, V <sub>IN</sub> : 2.5V to 36V, I <sub>Q</sub> = 250µA, I <sub>SD</sub> < 10µA, MS Package
LT1930/LT1930A	1A (I <sub>SW</sub> ), 1.2MHz/2.2MHz, High Efficiency Step-Up DC/DC Converter	High Efficiency, V <sub>IN</sub> : 2.6V to 16V, V <sub>OUT(MAX)</sub> = 34V, I <sub>Q</sub> = 4.2mA/5.5mA, I <sub>SD</sub> < 1µA, ThinSOT Package
LT1946/LT1946A	1.5A (I <sub>SW</sub> ), 1.2MHz/2.7MHz, High Efficiency Step-Up DC/DC Converter with Soft-Start	High Efficiency, V <sub>IN</sub> : 2.45V to 16V, V <sub>OUT(MAX)</sub> = 34V, I <sub>Q</sub> = 3.2mA, I <sub>SD</sub> < 1µA, MS8 Package
LT1961	1.5A (I <sub>SW</sub> ), 1.25MHz, High Efficiency Step-Up DC/DC Converter	90% Efficiency, V <sub>IN</sub> : 3V to 25V, V <sub>OUT(MAX)</sub> = 35V, I <sub>Q</sub> = 0.9mA, I <sub>SD</sub> < 6µA, MS8E Package
LTC3400/LTC3400B	600mA (I <sub>SW</sub> ), 1.2MHz, Synchronous Step-Up DC/DC Converter	92% Efficiency, V <sub>IN</sub> : 0.85V to 5V, V <sub>OUT(MAX)</sub> = 5V, I <sub>Q</sub> = 19µA/300µA, I <sub>SD</sub> < 1µA, ThinSOT Package
LTC3401	1A (I <sub>SW</sub> ), 3MHz, Synchronous Step-Up DC/DC Converter	97% Efficiency, V <sub>IN</sub> : 0.5V to 5V, V <sub>OUT(MAX)</sub> = 5.5V, I <sub>Q</sub> = 38µA, I <sub>SD</sub> < 1µA, MS Package
LTC3402	2A (I <sub>SW</sub> ), 3MHz, Synchronous Step-Up DC/DC Converter	97% Efficiency, V <sub>IN</sub> : 0.5V to 5V, V <sub>OUT(MAX)</sub> = 5.5V, I <sub>Q</sub> = 38µA, I <sub>SD</sub> < 1µA, MS Package
LTC3464	85mA (I <sub>SW</sub> ), High Efficiency Step-Up DC/DC Converter with Integrated Schottky and PNP Disconnect	V <sub>IN</sub> : 2.3V to 10V, V <sub>OUT(MAX)</sub> = 34V, I <sub>Q</sub> = 25µA, I <sub>SD</sub> < 1µA, ThinSOT Package

No R<sub>SENSE</sub> is a trademark of Linear Technology Corporation.

sn3467 3467afs