

DM132

Version : A.014
Issue Date : 2007/02/26
File Name : SP-DM132-A.014.doc
Total Pages : 24

16-Channel PWM-Controlled Constant Current Driver for LED Displays



新竹市科學園區展業一路9號7樓之1
SILICON TOUCH TECHNOLOGY INC.
9-7F-1, Prosperity Road I, Science Based Industrial Park,
Hsin-Chu, Taiwan 300, R.O.C
Tel : 886-3-5645656 Fax : 886-3-5645626



DM132

16-Channel PWM-Controlled Constant Current Driver for LED Displays

General Description

The DM132 is a LED driver incorporating shift registers, data latches, 16-channel constant current circuitry with current value set by an external resistor, 1024 gray level PWM (Pulse Width Modulation) functional unit and time division capability. Each channel can provide a maximum current of 60 mA. Time division operation allows driving up to 1 or 2 LEDs with a single output channel (mode-1 and mode-2 respectively).

Features

- Constant current outputs with current value settings by an external resistor
- Maximum output current: 60 mA
- Time division output allows the driving of 1 or 2 LEDs with a single output
- Maximum / minimum output voltage: 20V / 1.1V
- 10 bits luminance data with PWM current outputs
- Serial shift-in architecture for luminance data in time division Mode 1 and Mode 2

Block Diagram.

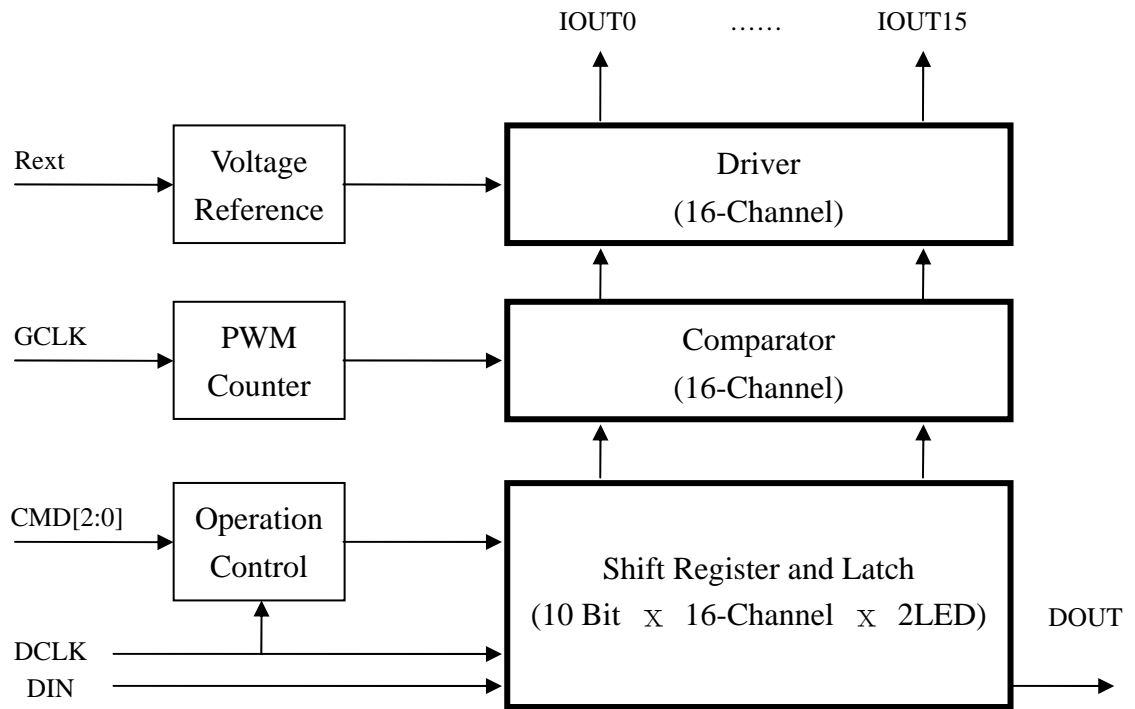
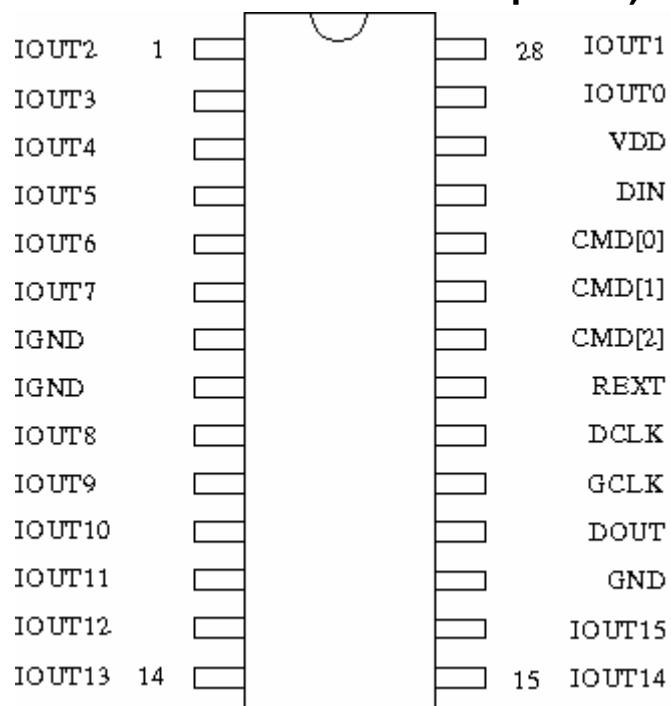

Figure 1. Functional block diagram

Pin Connection (SDIP28 / SOP28 / SSOP28 Top View)



Pin Assignment (SDIP28 / SOP28)

Pin No.	NAME	Pin No.	NAME
1	IOUT2	15	IOUT14
2	IOUT3	16	IOUT15
3	IOUT4	17	GND
4	IOUT5	18	DOUT
5	IOUT6	19	GCLK
6	IOUT7	20	DCLK
7	IGND	21	REXT
8	IGND	22	CMD[2]
9	IOUT8	23	CMD[1]
10	IOUT9	24	CMD[0]
11	IOUT10	25	DIN
12	IOUT11	26	VDD
13	IOUT12	27	IOUT0
14	IOUT13	28	IOUT1

Pin Connection (QFN32 Bottom View)

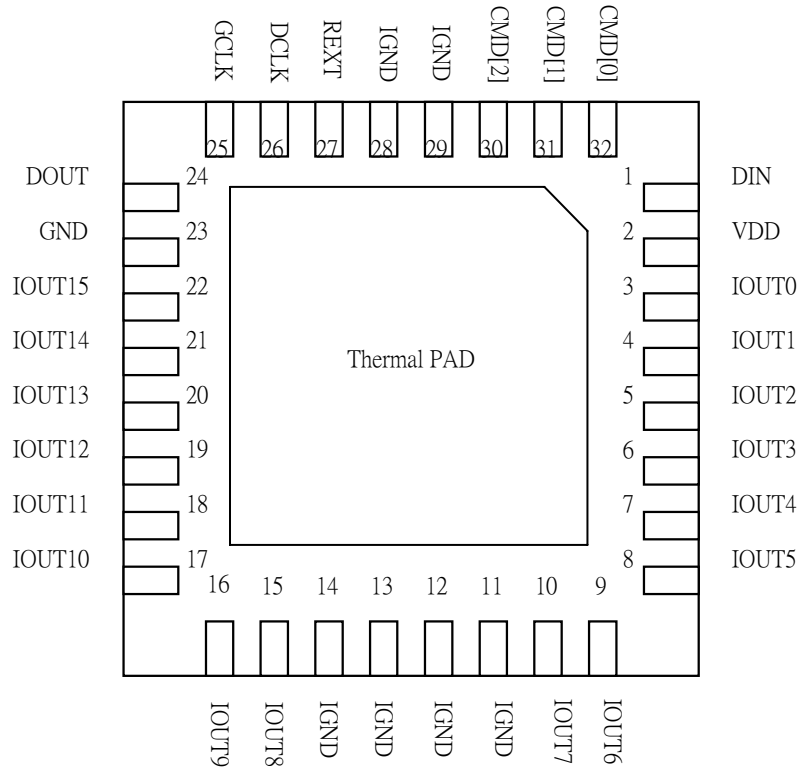

Pin Assignment (QFN32)

Pin No.	NAME	Pin No.	NAME	Pin No.	NAME
1	DIN	12	IGND	23	GND
2	VDD	13	IGND	24	DOUT
3	IOUT0	14	IGND	25	GCLK
4	IOUT1	15	IOUT8	26	DCLK
5	IOUT2	16	IOUT9	27	REXT
6	IOUT3	17	IOUT10	28	IGND
7	IOUT4	18	IOUT11	29	IGND
8	IOUT5	19	IOUT12	30	CMD[2]
9	IOUT6	20	IOUT13	31	CMD[1]
10	IOUT7	21	IOUT14	32	CMD[0]
11	IGND	22	IOUT15	Thermal PAD	IGND

Pin Description

NAME	PIN NO.	I/O	DESCRIPTION
CMD[2:0]	SDIP/SOP: 22, 23, 24 QFN: 30, 31, 32	I	Encoded commands for data transfer, time division operation and PWM display: CMD[2:0] Command [000]: Mode-1 time division operation / No operation for display [001]: Mode-2 time division operation / No operation for display [010]: Data transfer enable (Shift-In) [011]: Data latch strobe (Capture) [100]: First LED emitting [101]: Second LED emitting [110]: LED emitting disable / IOOUT disable (Stop) [111]: Test mode CMD commands are latched at the rising edges of DCLK.
DIN	SDIP/SOP: 25 QFN: 1	I	Serial input for luminance data (time division mode-1/2)
DOOUT	SDIP/SOP: 18 QFN: 24	O	Serial output for luminance data (time division mode-1/2)
DCLK	SDIP/SOP: 20 QFN: 26	I	Synchronous clock input for command and serial data transfer. The data input of DIN is synchronous to rising edges of DCLK.
GCLK	SDIP/SOP: 19 QFN: 25	I	Clock input for PWM operation
IOOUT0-15	SDIP/SOP: 27, 28, 1, 2, 3, 4, 5, 6, 9, 10, 11, 12, 13, 14, 15, 16 QFN: 3, 4, 5, 6, 9, 10, 15, 16, 17, 18, 19, 20, 21, 22	O	LED driver outputs
REXT	SDIP/SOP: 21 QFN: 27	O	Driver current setting. LED current is set to a current value by connecting an external resistor between REXT and GND.
VDD	SDIP/SOP: 26 QFN: 2	-	Power supply
GND	SDIP/SOP: 17 QFN: 23	-	Analog and digital ground
IGND	SDIP/SOP: 7, 8 QFN: 11, 12, 13, 14, 28, 29, Thermal pad	-	Ground-pin for driver outputs



Maximum Ratings (Ta = 25°C)

CHARACTERISTIC	SYMBOL	RATING	UNIT
Supply Voltage	V _{DD}	-0.3 ~ 7	V
Input Voltage Range	V _{IN}	-0.3 ~ DV _{DD} +0.3	V
Driver Output Voltage Range	V _{OUT}	-0.3 ~ 20	V
Driver Output Current	I _{OUT}	0 ~ 60	mA
Ground Thermal Current	I _{GND}	960	mA
Power Dissipation	P _D	2.50, SDIP28 1.32, SOP28 0.88, SSOP28 2.92, QFN32 (T _a = 50 °C or less)	W
Thermal Resistance	Θ _{ja}	40.0, SDIP28 75.9, SOP28 113.3, SSOP28 34.2, QFN32	°C / W
Operating temperature range	T _{op}	-40 ~ 85	°C
Storage temperature range	T _{stg}	-55 ~ 150	°C

Recommended Operating Conditions

DC Characteristics (Ta = 25°C)

PARAMETER	SYMBOL	CONDITIONS	MIN	NOM	MAX	UNIT
Supply voltage	V _{DD}	-	2.7	5	5.5	V
Driver output voltage when driver on	V _{OUT}	-	1.1	-	5	V
Driver output voltage when driver off ¹	V _{OUT}	-	0	-	20	V
Driver output current	I _{OUT}	OUTn	5	-	60	mA
High-level output current	I _{OH}	SERIAL-OUT	-	-	-1	mA
Low-level output current	I _{OL}	SERIAL-OUT	-	-	1	mA
High-level input voltage	V _{IH}	-	0.8V _{DD}	-	V _{DD} +0.2	V
Low-level input voltage	V _{IL}	-	-0.2	-	0.2 DV _{DD}	V
Operating free-air temperature ²	T _{op}	-	-20	-	80	°C

AC Characteristics (V_{DD} = 5.0 V, Ta = 25°C)

PARAMETER	SYMBOL	CONDITIONS	MIN	NOM	MAX	UNIT
DCLK clock frequency	f _{DCLK}	-	-	-	20	MHz
DCLK pulse duration	t _{wh} / t _{wl}	High or low level	20	-	-	ns
DCLK rise/fall time	t _r / t _f	-	-	-	40	ns
GCLK clock frequency	f _{GCLK}	-	-	-	20	MHz
GCLK pulse duration	t _{wh} / t _{wl}	High or low level	15	-	-	ns
GCLK rise/fall time	t _r / t _f	-	-	-	20	ns
Setup time	t _{su}	CMD to DCLK DIN to DCLK DCLK to CMD	25 25 25	-	-	ns
Hold time	t _h / t _{wh}	CMD to DCLK DIN to DCLK DCLK to CMD	25 25 25	-	-	ns

1. The driver output voltage including any overshoot stress has to be compliant with the maximum voltage (17V).
2. Recommended junction temperature range is from -20 to 150 °C.



Electrical Characteristics ($V_{DD} = 5.0V$, $T_a = 25^\circ C$)

PARAMETER	SYMBOL	CONDITIONS	MIN	NOM	MAX	UNIT
High-level digital output voltage	V_{OH}	-	$V_{DD}-0.5$	-	-	V
Low-level digital output voltage	V_{OL}	-	-	-	0.5	V
Input current	I_I	-	-	-	± 1	μA
Supply current (Digital)	$I_{DD}(\text{digital})$	DCLK = 1MHz GCLK = 1MHz	-	1	1.5	mA
Supply current (Analog)	$I_{DD}(\text{analog})$	REXT = 3K	-	10.4	11.2	mA
Voltage reference	V_{Rext}	Rext = 2K Ω	1.200	1.228	1.255	V
Driver output leakage current	I_{OL}	$V_{OH} = 17V$	-	-	1	μA
Driver current skew between channels	I_{OL1}	$V_{OUT} = 1V, I = 5mA$	-	± 2	± 4	%
Driver current skew between chips	I_{OL2}	$V_{OUT} = 1V, I = 5mA$	-	± 5	± 7	%
Supply Voltage Regulation	% / V_{DD}	Rext = 3K Ω	-	-	2	% / V

Switching Characteristics ($V_{DD} = 5.0V$, $T_a = 25^\circ C$)

CHARACTERISTIC	SYMBOL	CONDITIONS	MIN.	TYP.	MAX.	UNIT
DOUT Rise time	t_r	$V_{IH}=V_{DD}$	-	12	14	ns
DOUT Fall time	t_f	$V_{IL}=GND$	-	9	11	ns
DOUT Propagation delay (L to H)	t_{pLH}	REXT=3K Ω CL=13pF	-	22	23	ns
DOUT Propagation delay (H to L)	t_{pHL}		-	21	22	ns
IOUT Rise time	t_r	$V_{IH}=V_{DD}$	-	23	25	ns
IOUT Fall time	t_f	$V_{IL}=GND$	-	22	24	ns
IOUT Propagation delay After GCLK (L to H / OFF to ON)	t_{pLH}	REXT=3K Ω VLED=5.0V RL=120 Ω	-	17	19	ns
IOUT Propagation delay After GCLK (H to L / ON to OFF)	t_{pHL}	CL=33pF	-	17	19	ns

Switching Characteristics ($V_{DD} = 3.3V$, $T_a = 25^\circ C$)

CHARACTERISTIC	SYMBOL	CONDITIONS	MIN.	TYP.	MAX.	UNIT
DOUT Rise time	t_r	$V_{IH}=V_{DD}$	-	12	14	ns
DOUT Fall time	t_f	$V_{IL}=GND$	-	9	11	ns
DOUT Propagation delay (L to H)	t_{pLH}	REXT=3K Ω CL=13pF	-	25	26	ns
DOUT Propagation delay (H to L)	t_{pHL}		-	23	24	ns
IOUT Rise time	t_r	$V_{IH}=V_{DD}$	-	41	43	ns
IOUT Fall time	t_f	$V_{IL}=GND$	-	24	26	ns
IOUT Propagation delay After GCLK (L to H / OFF to ON)	t_{pLH}	REXT=3K Ω VLED=5.0V RL=120 Ω	-	20	22	ns
IOUT Propagation delay After GCLK (H to L / ON to OFF)	t_{pHL}	CL=33pF	-	24	26	ns

Typical Control Method

1) Command Sequence

To manipulate DM132, we should properly control the CMD, DIN, DCLK, and GCLK as following steps:

1. Issue command “*Shift-in*”, and then enter luminance data DIN. Note that DM132 starts to shift-in data at the DCLK rising edge next to the edge which latched *Shift-in* command.
2. After data are completely entered, send command “*Capture*” to save data in registers.
3. Issue command “*Emitting*” or “*Disable*”. Note that:
 - A. DM132 generates its output in one-shot fashion, i.e. the output after $(1024) \times T_{GCLK}$ is always zero.
 - B. There are 3 GCLK latencies between the latched *LED Emitting/Disable* command and PWM start/stop. This is shown in Figure 2.
4. Repeat step 1~4. In the same frame, the luminance data doesn’t have to be changed, just repeat step 3~4. Note that the second command “*Emitting*” will be omitted if the last $(1024) \times T_{GCLK}$ PWM has not finished, unless the “*Disable*” command is sent in advance.

The process discussed above could be summarized in the following table. At the same time, DCLK and GCLK remain free running.

Table 1. Example of Command Sequence

	Frame N-1			Frame N													Frame N+1					
CMD	NOP ³	Capture	<i>Emitting / Disable</i>	<i>Shift-In</i>	<i>Shift-In</i>	...	<i>Shift-In</i>	<i>Emitting / Disable</i>	<i>Shift-In</i>	<i>Shift-In</i>	...	<i>Shift-In</i>	<i>Emitting / Disable</i>	NOP	NOP	Capture
DIN	Don't care.	Don't care.	Don't care.	<i>Shift-in Data.</i>	<i>Shift-in Data</i>	...	<i>Shift-in Data</i>	Don't care	<i>Shift-in Data.</i>	<i>Shift-in Data</i>	...	<i>Shift-in Data</i>	Don't care.	Don't care.	Don't care.	Don't care.

³ We used the NOPs (No operation) to wait for the next frame data (at 60Hz) ready.

2) LED Emitting Time and Current

DM132 adjusts the LED luminance using PWM (pulse width modulation) technique. The luminance data (D_V) has a resolution of 10 bits (1024 steps) and can be set independently for each LED. The relationship between I_{out} , luminance data, and emitting time is shown in Figure 2.

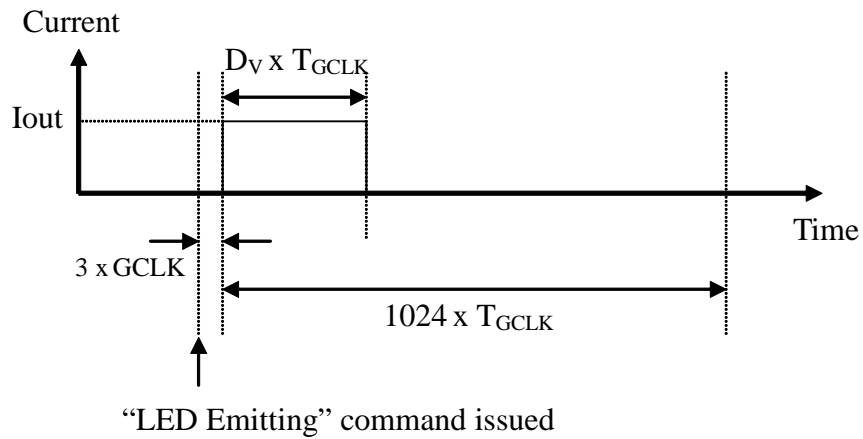
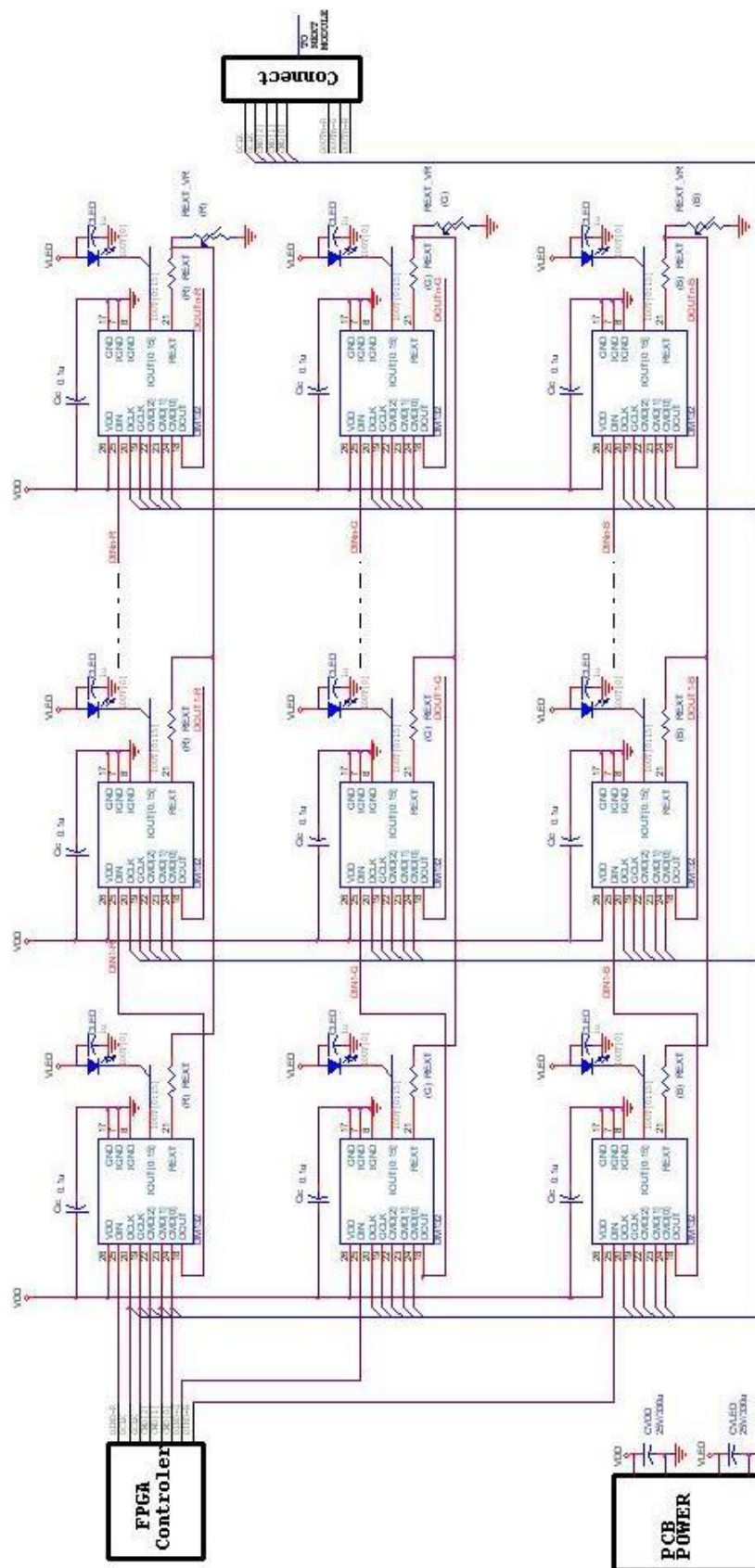

Figure 2. PWM Current Output

Application Diagrams

DM132 Application Circuit



(Constant Voltage Regulator)

* IGBT could be separated from GND to prevent from noise coupling.



Timing Diagrams

The timing diagram is an example of DM132 control and response. If DM132 has been set to MODE-1, users should issue the command and data in the sequence:

shift-in data ,latch data, and LED1 emitting.

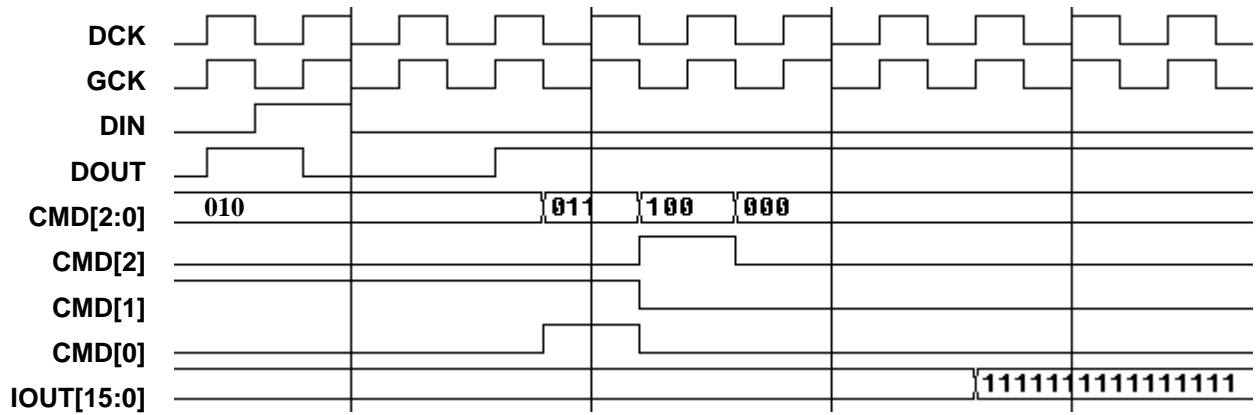

Detailed Description

1) Time Division Operation

Since each DM132 output could drive 1 LED or 2 LEDs, the users can choose either MODE1 luminance data or MODE2 luminance data. After the luminance data is given, a command should be issued so that the driver can operate in MODE1 or in MODE2. Figure 3 shows the route of data shift-in in MODE2. Later we will explain the data structure of MODE1 and MODE2 in more details.

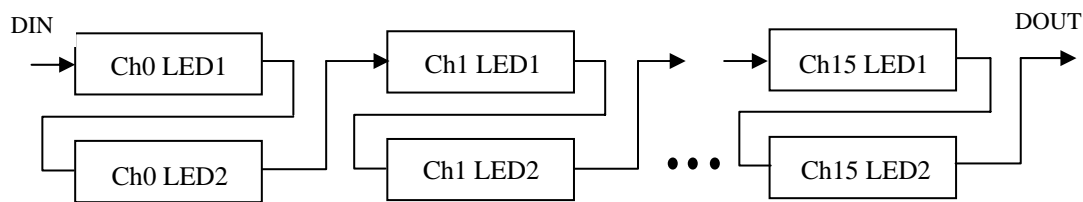

Figure 3. Block Diagram for Primary Bus.

Figure 4 shows how to switch between 2 LEDs. When “LED1 Emitting” command is sent, LED1 PWM output will start 3 GCLK later. At the same time, the switch of LED1 should be turned on. On the other hand, LED2 switch should be turned on when LED2 PWM output starts. Again, “Disable” command must be sent before “LED1/LED2 Emitting”. By periodically switching the emitting commands and LED switches, we could drive 2 LEDs per channel.

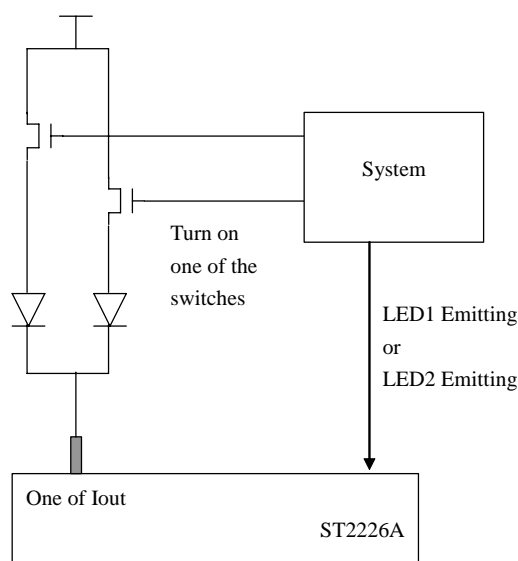

Figure 4. System Configuration for MODE 2 Operation

2) Serial Shift-In Luminance Data

In the MODE1 operation, the data for shift registers and latches is set as {16(channel) x 10 bit (luminance) x 1(led)} whereas in MODE2 operation, the data is set as {16(channel) x 10 bit (luminance) x 2(led)} configuration. The driver IC can remember both 2 sets of luminance data.

The serial shift architecture assumes a FIFO (first-in first-out) discipline, hence in the MODE1 operation, the most significant bit (MSB, Bit 9, Channel 15) luminance data is the first data shifted in, whereas the least significant bit (LSB, Bit 0, Channel 0) is the last data bit in a data set. The data structure for the MODE1 and MODE2 is shown in the Figure 5 and Figure 6 respectively.

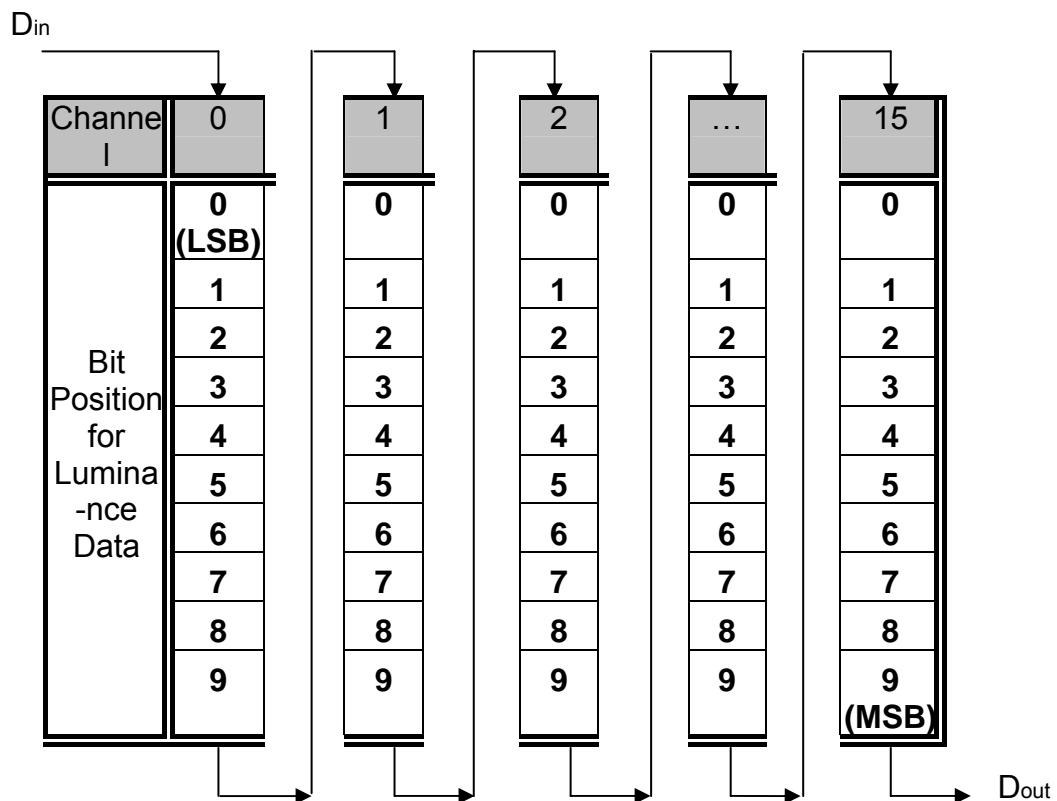

Figure 5. Luminance Data Structure in MODE 1

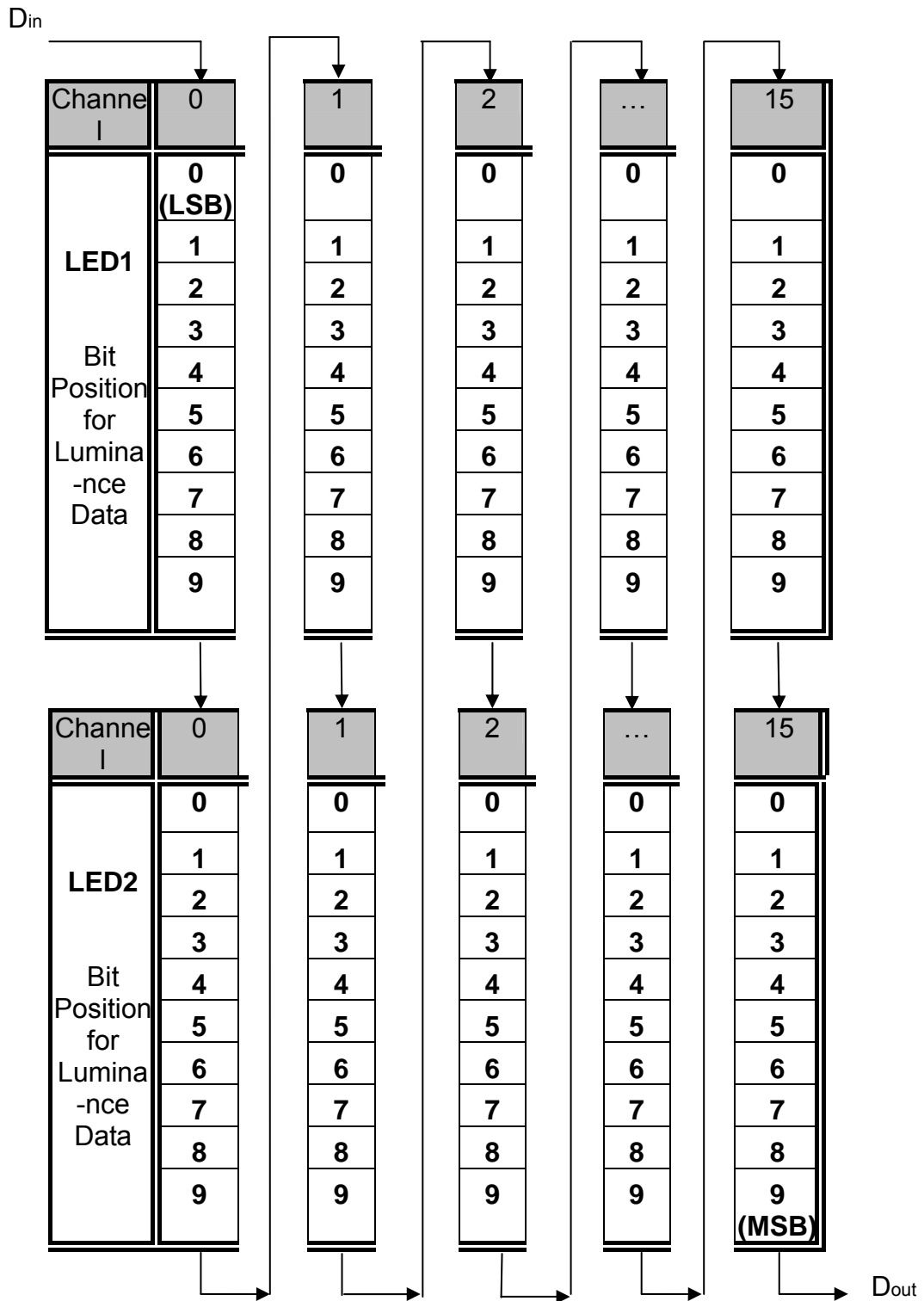

Figure 6. Luminance Data Structure in MODE 2

3) Driver Current Output

The drive current is set by an external resistor, R_{EXT} , connected between the REXT pin and GND. Varying the resistor value could adjust the current scale ranging from 5mA to the maximum 60 mA. Note that the REXT pin voltage is designed to be independent of supply voltage, temperature, and process variation, and is approximately 1.228V.

The output current could be calculated roughly by the following equation:

$$I_{out} = (1.228 / R_{EXT}) \times 48$$

The full-scale current I_{OUT} vs. R_{EXT} is shown in Figure 7.

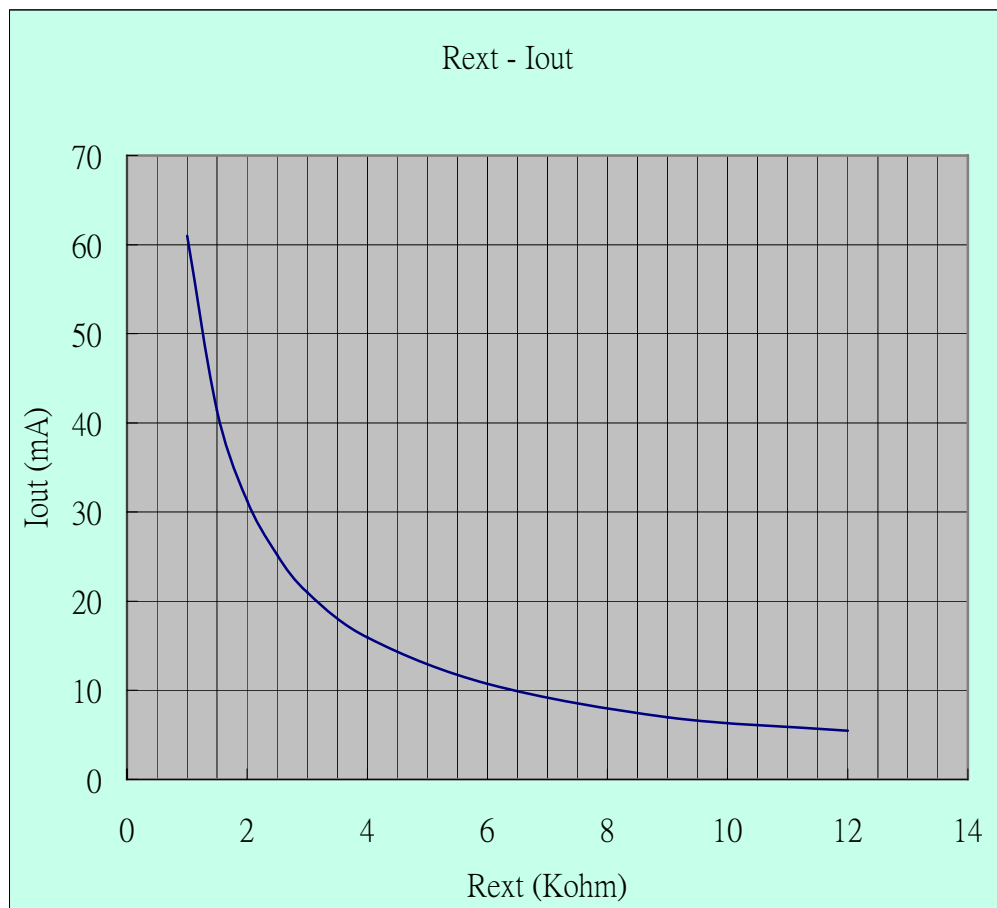

Figure 7. Driver current as a function of R_{EXT}

4) Output Current Performance vs. Output Voltage

In order to obtain a good constant current output, a suitable output voltage is necessary. Users can get related information about the minimum output voltage from Figure 8.

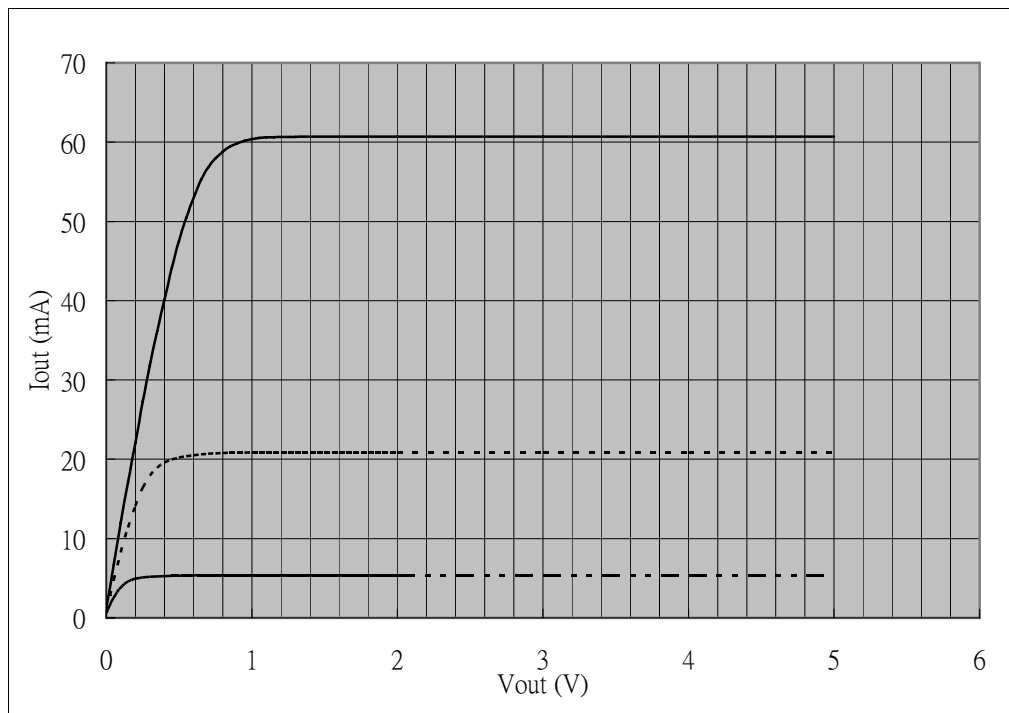

Figure 8. I_{out} vs. V_{out} (V_{DD}=5V)

5) Power Rating

For the relationship between power dissipation and operating temperature, please refer to Figure 9.

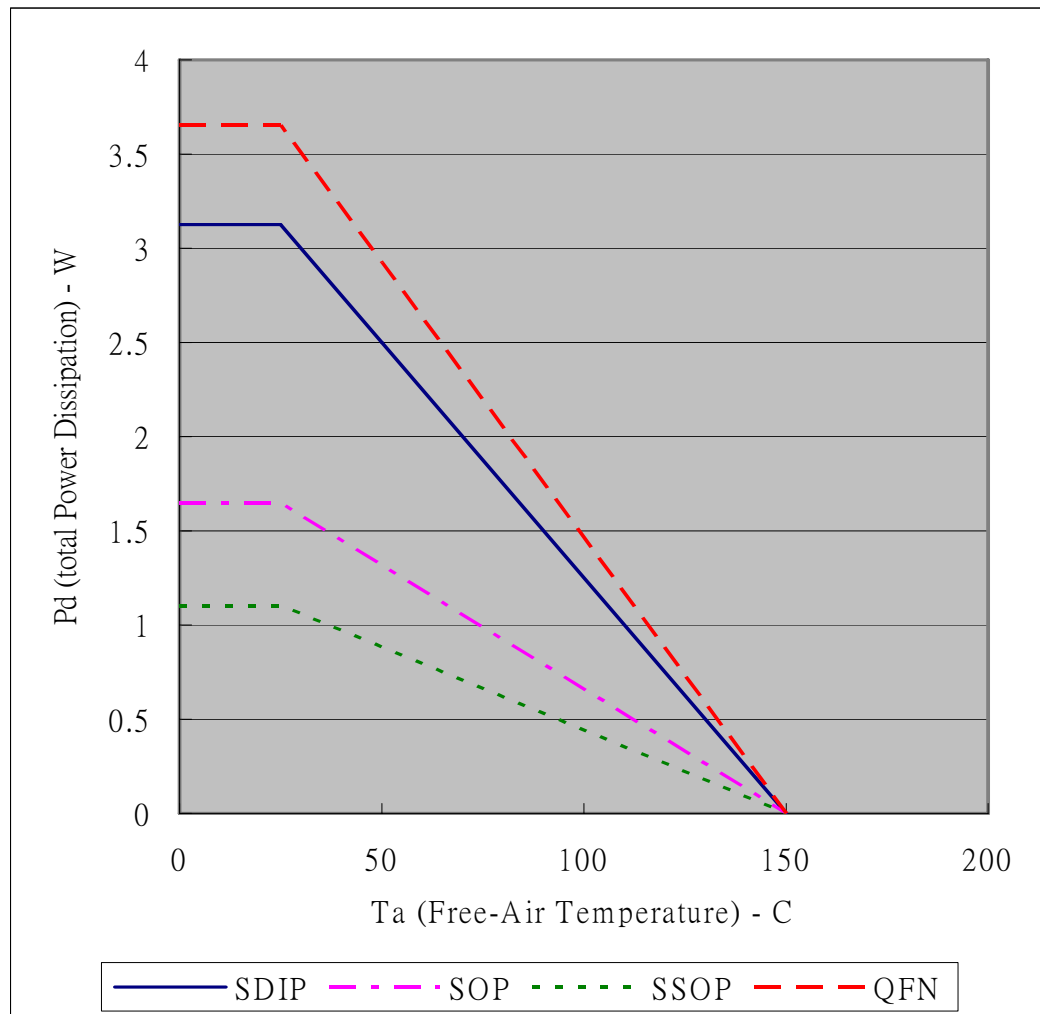

Figure 9. Power Dissipation vs. Operating Temperature

6) Advantages for application

To understand what the advantages over ON-OFF type drivers, we assume that in MODE 1 operation, the frame rate is 60Hz, DCLK & GCLK both run at 10MHz. We can shift in $(1/60\text{Hz})/(1/10\text{MHz})=167\text{K}$ bits per frame. One channel takes 10 bits, thus $167\text{K}/10=16.7\text{K}$ channels (single color pixels). For two dimension display, we take the square root of 16.7K pixels, which equals 129. The resolution, in this case is 129*129. We can round the data a little bit, and we can construct a 128*128 image by



connecting 1024 driver ICs. (1,024 EA drivers*16 channels = 16,384 bit).

Within a frame, there are $1024 \times 16 \times 10 = 163K$ DCLK & GCLK cycles, and we know that the PWM takes 1024 GCLK cycles and is one-shot. So we can issue up to $163K/1024 = 160$ PWM cycles within a frame. This can be used as an 160-level total brightness control in addition to the 1024-level pixel-dependent luminance control. These 160- “LED1 Emitting” shall be issued periodically within a frame. Each time when issuing the “LED1 Emitting” command, the shift-in process will be pended for a few cycles; however, we can resume feeding the data right after the “LED1 Emitting” command is issued.

To make the total brightness at full scale, all 160 “LED1 Emitting” commands should be issued. To make the total brightness half of the full scale, we can issue 80-“LED1 Emitting” commands in companion with 80-“LED Disable” commands, so that all the 128×128 LEDs are half of their brightness.

A comparison table for PWM LED driver vs. ON-OFF type is provided for reference.

Table 2. Comparison between PWM and ON-OFF Free Running

	PWM	ON-OFF
Frame rate	60	60
No. shift-in pixels	128 x 128	128 x 128
Grayscale for each pixel	1024	1024
Grayscale for overall panel	160	1
Clocks needed per frame	167k	16.8Meg
Clock rate	10 MHz	1.0 GHz ⁴

⁴ Surely out of spec. Can't realize in this configuration. System designs for ON-OFF type drivers thus need to reduce frame rate or the no. shift-in pixels or grayscale level for each pixel.

Package Outline Dimension

SDIP28

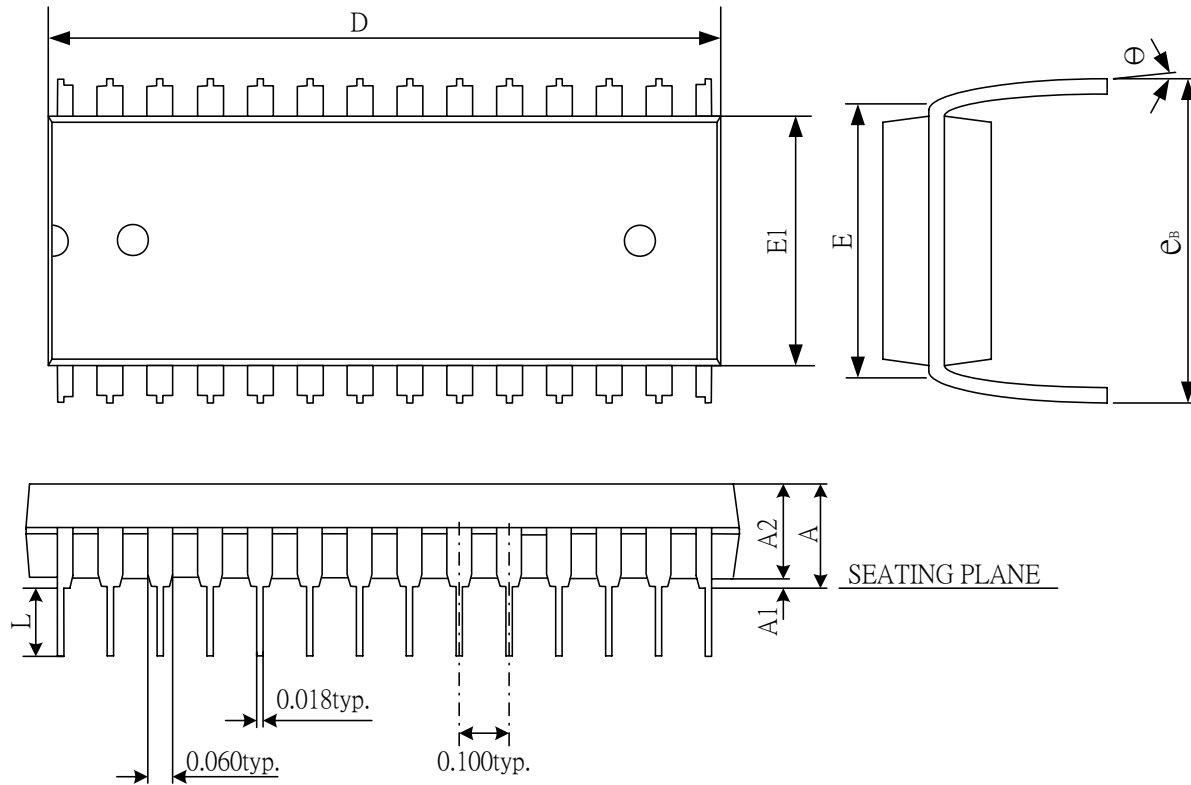

SYMBOLS	DIMENSION IN INCH		
	MIN.	NOM.	MAX.
A	-	-	0.210
A1	0.015	-	-
A2	0.125	0.130	0.135
D	1.385	1.390	1.400
E1	0.283	0.288	0.293
E	0.31 BSC		
L	0.115	0.130	0.150
e_B	0.330	0.350	0.370
θ	0	7	15

Note:

1. JEDEC OUTLINE : N/A

SOP28

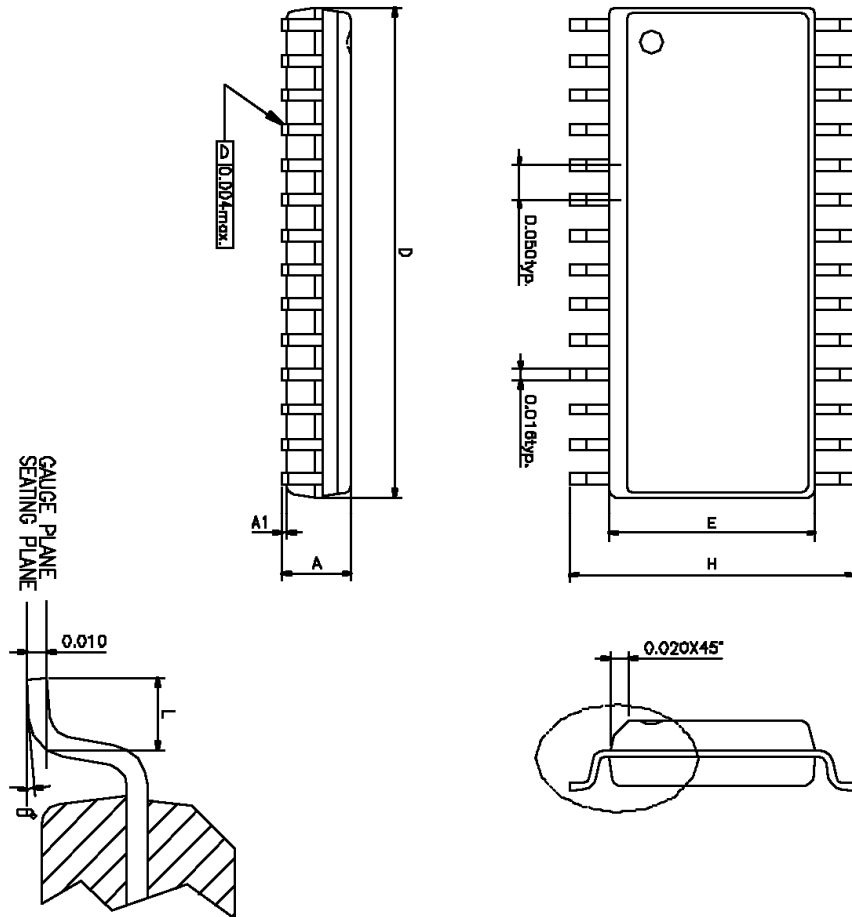

SYMBOLS	MIN.	MAX.
A	0.093	0.104
A1	0.004	0.012
D	0.697	0.713
E	0.291	0.299
H	0.394	0.419
L	0.016	0.050
Ø	0	8

UNIT : INCH

- NOTES:
1. JEDEC OUTLINE : MS-013 AE
 2. DIMENSIONS "D" DOES NOT INCLUDE MOLD FLASH, PROTRUSIONS OR GATE BURRS. MOLD FLASH, PROTRUSIONS AND GATE BURRS SHALL NOT EXCEED .15mm (.006in) PER SIDE.
 3. DIMENSIONS "E" DOES NOT INCLUDE INTER-LEAD FLASH, OR PROTRUSIONS. INTER-LEAD FLASH AND PROTRUSIONS SHALL NOT EXCEED .25mm (.010in) PER SIDE.

SSOP28

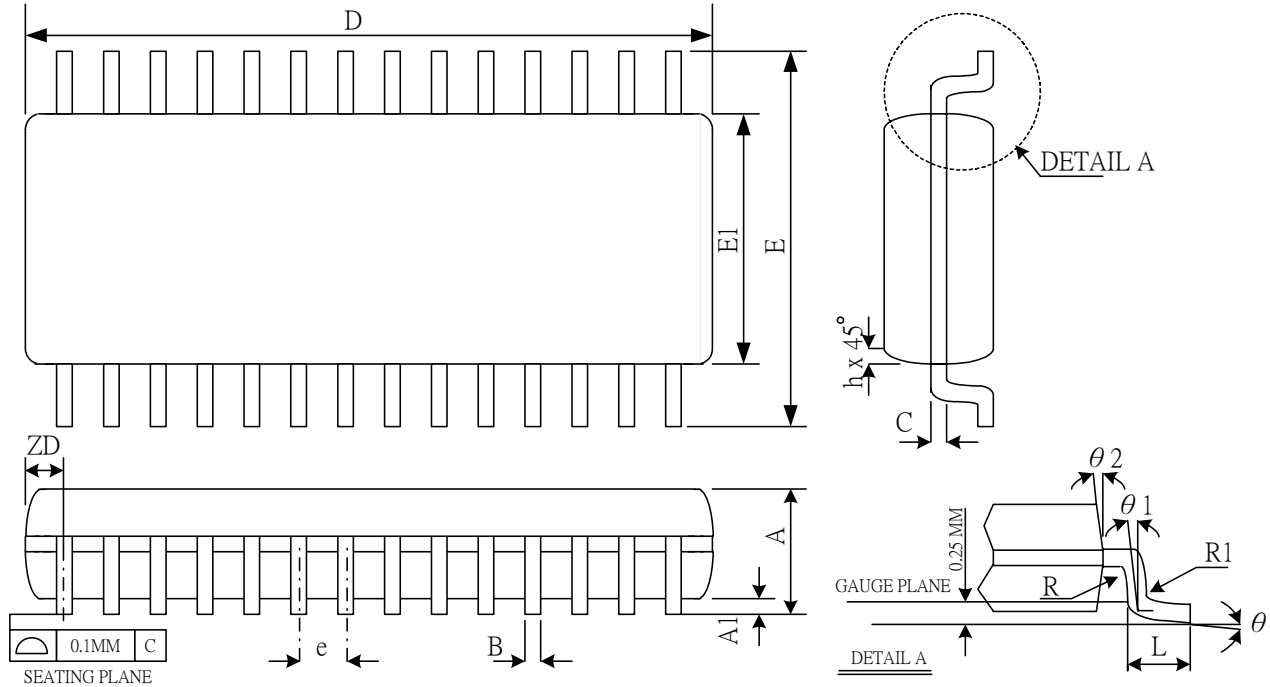

NOTES: DIMENSION D DOES NOT INCLUDE MOLD PROTRUSIONS OR GATE BURRS.
MOLD PROTRUSIONS AND GATE BURRS SHALL NOT EXCEED 0.006 INCH PER SIDE

SYMBOL	DIMENSION IN MM			DIMENSION IN INCH		
	MIN.	NOM.	MAX.	MIN.	NOM.	MAX.
A	1.35	1.63	1.75	0.053	0.064	0.069
A1	0.1	0.15	0.25	0.004	0.006	0.01
A2			1.5			0.059
B	0.2		0.3	0.008		0.012
C	0.18		0.25	0.007		0.01
e	0.635 BASIC			0.025 BASIC		
D	9.80	9.91	10.01	0.386	0.39	0.394
E	5.79	5.99	6.20	0.228	0.236	0.244
E1	3.81	3.91	3.99	0.150	0.154	0.157
L	0.41	0.635	1.27	0.016	0.025	0.05
h	0.25		0.5	0.01		0.02
ZD	0.838 REF			0.033 REF		
R1	0.2		0.33	0.008		0.013
R	0.2			0.008		
θ	0		8	0		8
θ1	0			0		
θ2	5	10	15	5	10	15
JEDEC	MO - 137 (AF)					

QFN32

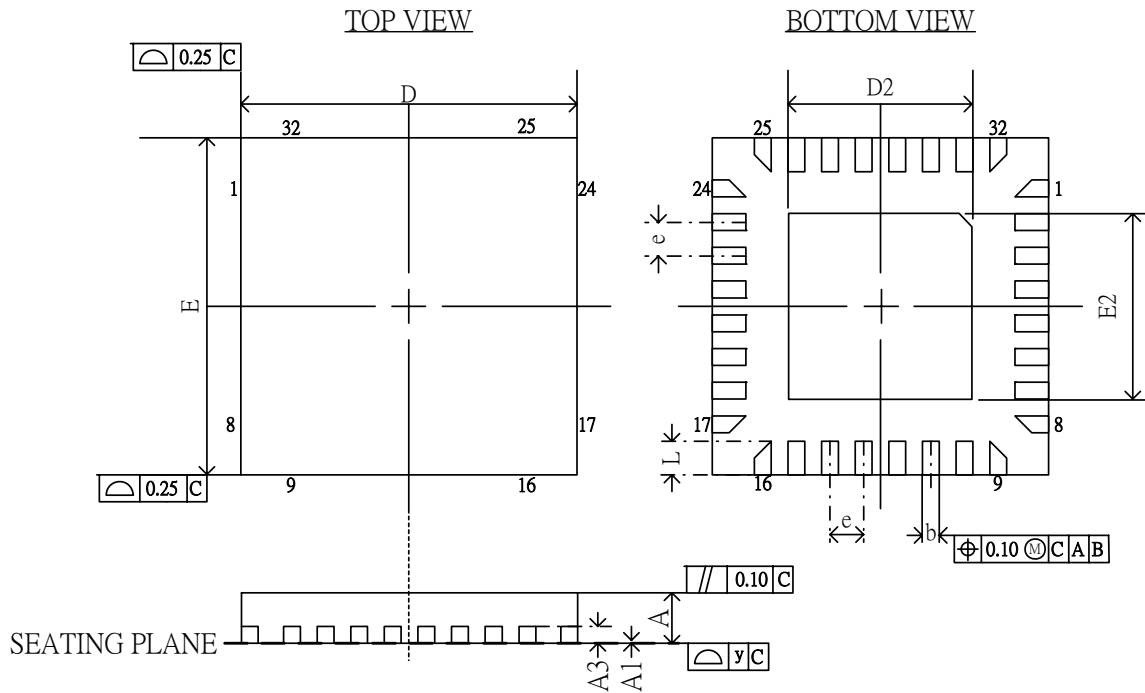

SYMBOL	DIMENSION (mm)			DIMENSION (MIL)		
	MIN.	NOM.	MAX.	MIN.	NOM.	MAX.
A	0.70	0.75	0.80	27.6	29.5	31.5
A1	0	0.02	0.05	0	0.79	1.97
A3	0.25 REF			9.84 REF		
b	0.18	0.23	0.30	7.09	9.06	11.81
D	5.00 BSC			196.85 BSC		
D2	1.25	2.70	3.25	49.21	106.30	127.95
E	5.00 BSC			196.85 BSC		
E2	1.25	2.70	3.25	49.21	106.30	127.95
e	0.50 BSC			19.69 BSC		
L	0.30	0.40	0.50	11.81	15.75	19.69
y	0.10			3.94		

Note: 1. DIMENSIONING AND TOLERANCING CONFORM TO ASME Y145.5M-1994.

2. REFER TO JEDEC STD. MO-220 WHHD-2 ISSUE A



The products listed herein are designed for ordinary electronic applications, such as electrical appliances, audio-visual equipment, communications devices and so on. Hence, it is advisable that the devices should not be used in medical instruments, surgical implants, aerospace machinery, nuclear power control systems, disaster/crime-prevention equipment and the like. Misusing those products may directly or indirectly endanger human life, or cause injury and property loss.

Silicon Touch Technology, Inc. will not take any responsibilities regarding the misuse of the products mentioned above. Anyone who purchases any products described herein with the above-mentioned intention or with such misused applications should accept full responsibility and indemnify. Silicon Touch Technology, Inc. and its distributors and all their officers and employees shall defend jointly and severally against any and all claims and litigation and all damages, cost and expenses associated with such intention and manipulation.