

Compatible with Eu Directive
 2002/EC - RoHS

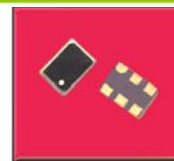

ACT9212 LVPECL / LVDS OSCILLATOR

The ACT9212 PECL / LVDS Oscillator is a miniature low profile device allowing for frequencies from 181.0 to 650.0 MHz to be available in a 7X5 mm Surface Mount Device.

This device is suitable for a wide range of applications where board space dictates small size and / or automatic assembly is a requirement. It is suitable for design into many applications including Communications Equipment, Networking and many more.

Specification

Parameter	Symbol	Specification	Condition
Frequency Range	fo	181.0 ~ 650.00 MHz (PLL)	Please specify
Frequency Stability	Df/fo	Please refer to Table 1	Please specify
Temp Operating Range	Topr	0 ~ +70°C Std, -40 ~ +85°C also available	Please specify
Temp Storage Range	Tstg	-55 to +125°C	
Supply Voltage	Vdd	2.5VDC & 3.3VDC ± 5%	Please specify
Supply Current (max)	Iop	70mA Up to 320.0 MHz 90mA 321.0 ~650.0 MHz 65mA 181.0~ 650.0 MHz 80mA Up to 320.0 MHz 100mA 321.0 ~650.0 MHz 65mA 181.0 ~ 650.0 MHz	2v5VDC LVPECL 2v5VDC LVPECL 2v5VDC LVDS 3.3VDC LVPECL 3.3VDC LVPECL 3.3VDC LVDS
Duty Cycle	Tw/t	40 / 60% Std	VDD -1.30VDC - LVPECL 1.25VDC - LVDS
Output Level '0'	VOL	VDD -1.63VDC max (LVPECL) 1.125VDC max (LVDS)	
Output Level '1'	VOH	VDD -1.02VDC min (LVPECL) 1.375VDC min (LVDS)	
Rise & Fall Time (max)	Tr/Tf	0.6nS Typical	@ 20/80%
Output Load	N/CL	50Ω into VDD -2.0V (LVPECL) 100Ω differential Load (LVDS)	
Start-up Time	Tosc	10mS max	
Aging	Fa	±3ppm / year max	
Reflow		See reflow profile (Page 2)	
Jitter	Tj	5pS RMS max	

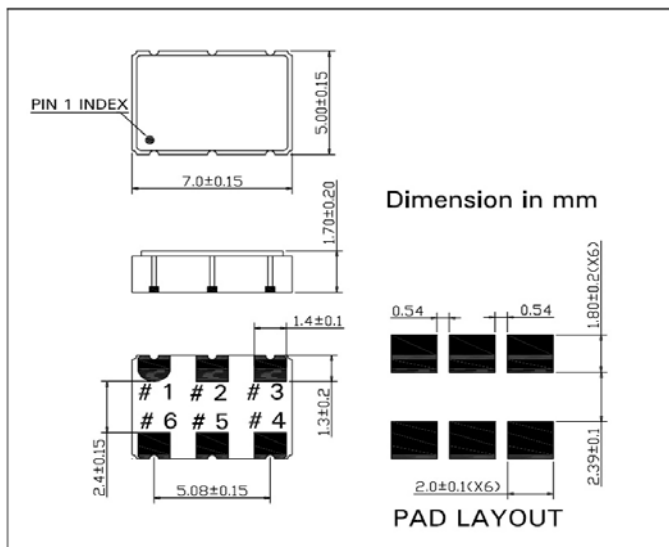

Pin Connection	
#1	Tri-State
#2	N/C
#3	Ground
#4	Output
#5	Complementary Output
#6	Vdd

Pad surface material
 AU

Table 1 Frequency Stability v (Temperature, Aging, Vdd±5% Load change, & Adjustment at 25°C)

	+/-20ppm	+/-25ppm	+/-30ppm	+/-50ppm	+/-100ppm
-10 ~ +70°C	★	★	★	Standard	★
-20~+70°C	★	★	★	★	★
-40 ~ +85°C			★	★	★

Please note that all parameters can not necessarily be specified in the same device

Customer to specify :Frequency, Frequency Stability, Operating Temperature Range, Output enable, Voltage, Duty Cycle & Output typ
 In line with our ongoing policy of product evolution and improvement, the above specification is subject to change without notice.

ISO9001:2000 Registered

For quotations or further information please contact us at:
 3 The Business Centre, Molly Millars Lane, Wokingham, Berks, RG41 2EY, UK

<http://www.actcrystals.com>

Issue :2 D2
 Date : 9/11/05

ACT9212
TAPE AND REEL DIMENSIONS (mm)
REELS OF 1KPCS

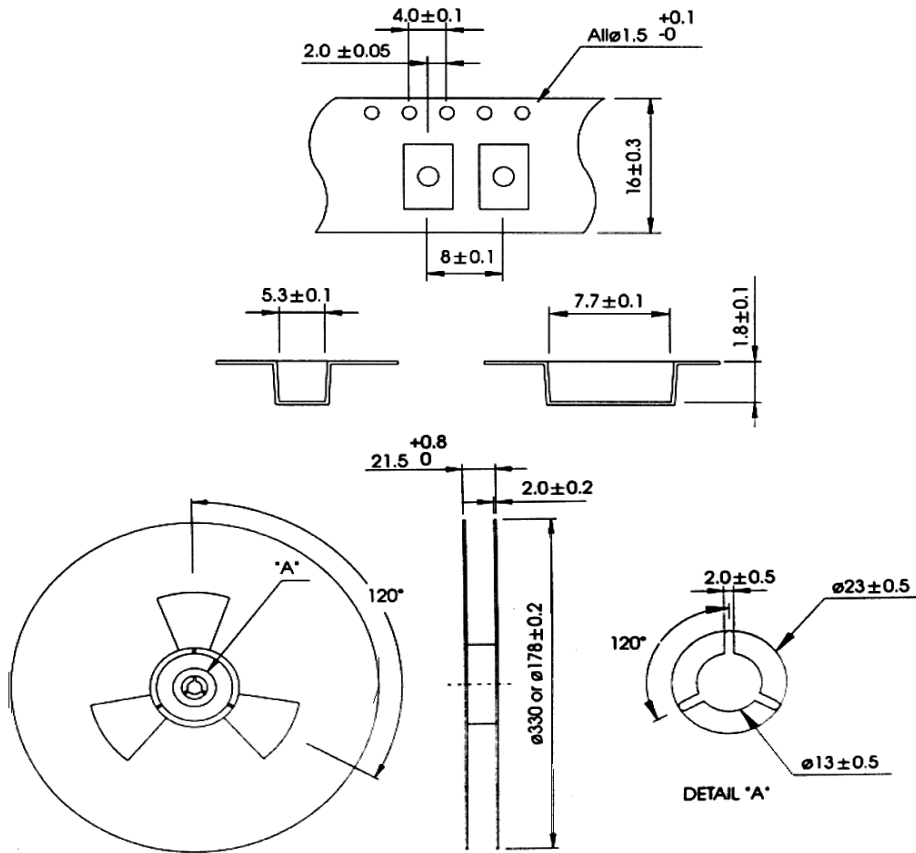

Recommended Reflow soldering Condition

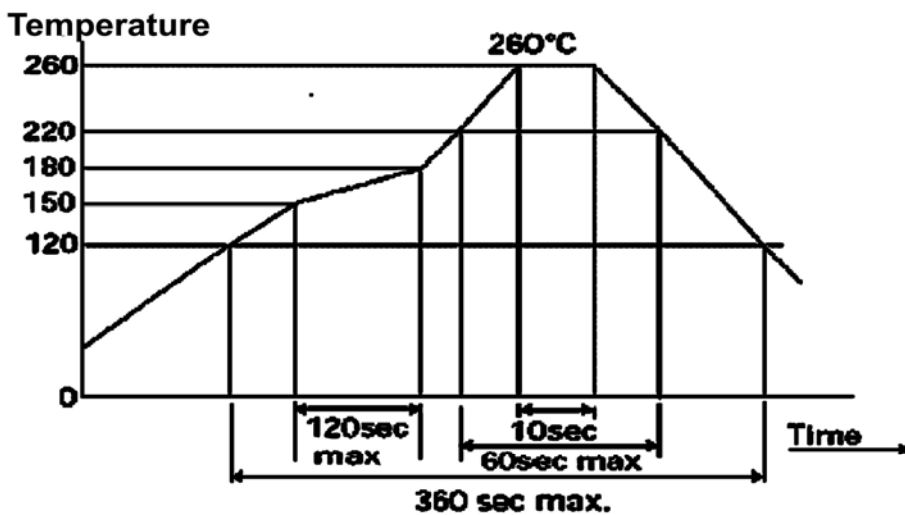

In line with our ongoing policy of product evolution and improvement, the above specification is subject to change without notice.

ISO9001: 2000 Registered

Issue : 2 D2

Date : 9/11/05

For quotations or further information please contact us at:

3 The Business Centre, Molly Millars Lane, Wokingham, Berks, RG41 2EY, UK

<http://www.actcrystals.com>