

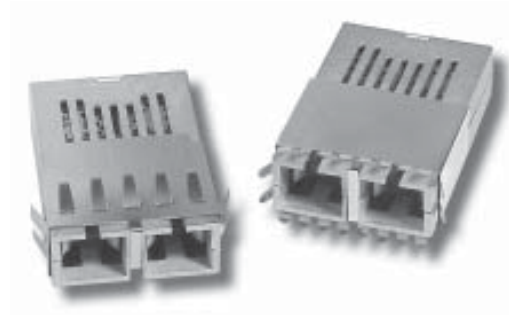

Agilent HFBR-53B3EM/HFBR-53B3FM 5 V 1 x 9 Fiber Optic Transceivers for Gigabit Ethernet (GbE) and Fibre Channel (FC) Data Sheet



Description

The HFBR-53B3EM/FM transceivers from Agilent allow the system designer to implement a range of solutions for multimode GbE and FC applications.

The overall Agilent transceiver product consists of three sections: the transmitter and receiver optical subassemblies, an electrical subassembly, and the package housing which incorporates a duplex SC connector receptacle.

Transmitter Section

The transmitter section of the HFBR-53B3EM/FM consists of an 850 nm Vertical Cavity Surface Emitting Laser (VCSEL) in an Optical Subassembly (OSA), which mates to the fiber cable. The OSA is driven by a custom, silicon bipolar IC which converts differential PECL compatible logic signals into an analog laser diode drive current. The high speed output lines are internally ac-coupled and differentially terminated with a 100 Ω resistor.

Receiver Section

The receiver of the HFBR-53B3EM/FM includes a GaAs PIN photodiode mounted together with a custom, silicon bipolar transimpedance preamplifier IC in an OSA. This OSA is mated to a custom silicon bipolar circuit that provides post-amplification and quantization.

The post-amplifier also includes a Signal Detect circuit which provides a PECL logic-high output upon detection of a usable input optical signal level. This single-ended PECL output is designed to drive a standard PECL input through a 50 ohm PECL load. The high speed output lines are dc-coupled, different from the transmitter.

Features

- Compliant with ANSI X3.297-1996 Fibre Channel Physical Interface FC-PH-2 revision 7.4 proposed specification for 100-M5-SN-I and 100-M6-SN-I signal interfaces
- Compliant with IEEE-802.3z Gigabit Ethernet specifications
- 300 m links in 62.5/125 mm MMF cables
- 500 m links in 50/125 mm MMF cables
- Wave solder and aqueous wash process compatible
- Industry standard mezzanine height 1 x 9 package style with integral duplex SC connector
- IEC 60825-1 Class 1 / CDRH Class I laser eye safe
- Single +5V power supply operation with PECL compatible logic interfaces and PECL Signal Detect
- AC/DC Couple

Applications

- Switch to switch interface
- Switched backbone applications
- Mass storage systems I/O
- Computer systems I/O
- High-speed peripheral interface
- High-speed switching systems
- Computer systems I/O

Related Products

- Physical layer ICs available for optical or copper interface (HDMP-1636A/1646A)
- Versions of this transceiver module also available for +3.3V operation (HFBR-53A5V/53A3V)
- MT-RJ SFF fiber optic transceivers for GbE and FC (HFBR-5912E/5912E)
- Gigabit Interface Converters (GBIC) for GbE and FC (HFBR-5601/5602)



Package and Handling Instructions

Flammability

The HFBR-53B3EM/FM transceiver housing is made of high strength, heat resistant, chemically resistant and UL 94V-0 flame retardant plastic.

Recommended Solder and Wash Process

The HFBR-53B3EM/FM is compatible with industry-standard wave or hand solder processes.

Process Plug

This transceiver is supplied with a process plug (HFBR-5000) for protection of the optical ports within the duplex SC connector receptacle. This process plug prevents contamination during wave solder and aqueous rinse as well as during handling, shipping and storage. It is made of a high-temperature, molded sealing material that can withstand +85°C and a rinse pressure of 110 lbs per square inch.

Recommended Solder Fluxes

Solder fluxes used with the HFBR-53B3EM/FM should be water-soluble, organic fluxes. Recommended solder fluxes include Lonco 3355-11 from London Chemical West, Inc. of Burbank, CA, and 100 Flux from Alpha-Metals of Jersey City, NJ.

Recommended Cleaning/ Degreasing Chemicals

Alcohols: methyl, isopropyl, isobutyl.

Aliphatics: hexane, heptane.

Other: soap solution, naphtha.

Do not use partially halogenated hydrocarbons such as 1,1,1 trichloroethane, ketones such as MEK, acetone, chloroform, ethyl acetate, methylene dichloride, phenol, methylene chloride, or N-methylpyrrolidone. Also, Agilent does not recommend the use of cleaners that use halogenated hydrocarbons because of their potential environmental harm.

Regulatory Compliance

(See the Regulatory Compliance Table for transceiver performance) The overall equipment design will determine the certification level. The transceiver performance is offered as a figure of merit to assist the designer in considering their use in equipment designs.

Electrostatic Discharge (ESD)

There are two design cases in which immunity to ESD damage is important.

The first case is during handling of the transceiver prior to mounting it on the circuit board. It is important to use normal ESD handling precautions for ESD sensitive devices. These precautions include using grounded wrist straps, work benches, and floor mats in ESD controlled areas. The transceiver performance has been shown to provide adequate performance in typical industry production environments.

The second case to consider is static discharges to the exterior of the equipment chassis containing the transceiver parts. To the extent that the duplex SC connector receptacle is exposed to the outside of the equipment chassis it may be subject to whatever system-level ESD test criteria that the equipment is intended to meet. The transceiver performance is more robust than typical industry equipment requirements of today.

Electromagnetic Interference (EMI)

Most equipment designs utilizing these high-speed transceivers from Agilent will be required to meet the requirements of FCC in the United States, CENELEC EN55022 (CISPR 22) in Europe and VCCI in Japan. Refer to EMI section (page 4) for more details.

Immunity

Equipment utilizing these transceivers will be subject to

radio-frequency electromagnetic fields in some environments. These transceivers have good immunity to such fields due to their shielded design.

Eye Safety

These laser-based transceivers are classified as AEL Class I (U.S. 21 CFR(J) and AEL Class 1 per EN 60825-1 (+A11)). They are eye safe when used within the data sheet limits per CDRH. They are also eye safe under normal operating conditions and under all reasonably foreseeable single fault conditions per EN60825-1. Agilent has tested the transceiver design for compliance with the requirements listed below under normal operating conditions and under single fault conditions where applicable. TUV Rheinland has granted certification to these transceivers for laser eye safety and use in EN 60950 and EN 60825-2 applications. Their performance enables the transceivers to be used without concern for eye safety up to maximum volts transmitter V_{CC} .

CAUTION:

There are no user serviceable parts nor any maintenance required for the HFBR-53B3EM/FM. All adjustments are made at the factory before shipment to our customers. Tampering with or modifying the performance of the HFBR-53B3EM/FM will result in voided product warranty. It may also result in improper operation of the HFBR-53B3EM/FM circuitry, and possible overstress of the laser source. Device degradation or product failure may result.

Connection of the HFBR-53B3EM/FM to a nonapproved optical source, operating above the recommended absolute maximum conditions or operating the HFBR-53B3EM/FM in a manner inconsistent with its design and function may result in hazardous radiation exposure and may be considered an act of modifying or manufacturing a laser product. The person(s) performing such an act is required by law to recertify and reidentify the laser product under the provisions of U.S. 21 CFR (Subchapter J).

Regulatory Compliance

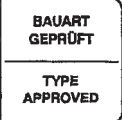
Feature	Test Method	Performance
Electrostatic Discharge (ESD) to the Electrical Pins	MIL-STD-883C Method 3015.4	Class 1 (>1500 V).
Electrostatic Discharge (ESD) to the Duplex SC Receptacle	Variation of IEC 801-2	Typically withstand at least 15 kV without damage when the duplex SC connector receptacle is contacted by a Human Body Model probe.
Electromagnetic Interference (EMI)	FCC Class B CENELEC EN55022 Class B (CISPR 22A) VCCI Class I	Margins are dependent on customer board and chassis designs.
Immunity	Variation of IEC 801-3	Typically show no measurable effect from a 10 V/m field swept from 27 to 1000 MHz applied to the transceiver without a chassis enclosure.
Laser Eye Safety and Equipment Type Testing	US 21 CFR, Subchapter J per Paragraphs 1002.10 and 1002.12	AEL Class I, FDA/CDRH
 	EN 60825-1: 1994 + A11:1996	AEL Class 1, TUV Rheinland of North America
	EN 60825-2: 1994 + A1	
	EN 60950: 1992 + A1 + A2 + A3 + A4 + A11	Protection Class III
Component Recognition	Underwriters Laboratories and Canadian Standards Association Joint Component Recognition for Information Technology Equipment Including Electrical Business Equipment.	UL File E173874

APPLICATION SUPPORT

Optical Power Budget and Link Penalties

The worst-case Optical Power Budget (OPB) in dB for a fiber-optic link is determined by the difference between the minimum transmitter output optical power (dBm avg) and the lowest receiver sensitivity (dBm avg). This OPB provides the necessary optical signal range to establish a working fiber-optic link. The OPB is allocated for the fiber-optic cable length and the corresponding link penalties. For proper link performance, all penalties that affect the link performance must be accounted for within the link optical power budget.

Data Line Interconnections

Agilent's HFBR-53B3EM/FM fiber-optic transceiver is designed for PECL compatible signals. The transmitter inputs are internally ac-coupled to the laser driver circuit from the transmitter input pins (pins 7, 8). The transmitter driver circuit for the laser light source is an ac-coupled circuit. This circuit regulates the output optical power. The regulated light output will maintain a constant output optical power provided the data pattern is reasonably balanced in duty factor. If the data duty factor has long, continuous state times (low or high data duty factor), then the output optical power will gradually change its average output optical power level to its preset value.

The receiver section is internally ac-coupled between the pre-amplifier and the post-amplifier

stages. The actual Data and Data-bar outputs of the post-amplifier are dc-coupled to their respective output pins (pins 2, 3). Signal Detect is a single-ended, TTL output signal that is dc-coupled to pin 4 of the module. Signal Detect should not be ac-coupled externally to the follow-on circuits because of its infrequent state changes.

Caution should be taken to account for the proper interconnection between the supporting Physical Layer integrated circuits and this HFBR-53B3EM/FM transceiver. Figure 3 illustrates a recommended interface circuit for interconnecting to a PECL compatible fiber-optic transceiver.

Eye Safety Circuit

For an optical transmitter device to be eye-safe in the event of a single fault failure, the transmitter must either maintain normal, eye-safe operation or be disabled.

In the HFBR-53B3EM/FM there are three key elements to the laser driver safety circuitry: a monitor diode, a window detector circuit, and direct control of the laser bias. The window detection circuit monitors the average optical power using the monitor diode. If a fault occurs such that the transmitter dc regulation circuit cannot maintain the preset bias conditions for the laser emitter within $\pm 20\%$, the transmitter will automatically be disabled. Once this has occurred, only an electrical power reset will allow an attempted turn-on of the transmitter.

Signal Detect

The Signal Detect circuit provides a TTL low output signal when the optical link is broken or when the transmitter is off. The Signal Detect threshold is set to transition from a high to low state

between the minimum receiver input optional power and -30 dBm avg. input optical power indicating a definite optical fault (e.g. unplugged connector for the receiver or transmitter, broken fiber, or failed far-end transmitter or data source). A Signal Detect indicating a working link is functional when receiving encoded 8B/10B characters. The Signal Detect does not detect receiver data error or error-rate. Data errors are determined by signal processing following the transceiver.

Electromagnetic Interference (EMI)

One of a circuit board designer's foremost concerns is the control of electromagnetic emissions from electronic equipment. Success in controlling generated Electromagnetic Interference (EMI) enables the designer to pass a governmental agency's EMI regulatory standard; and more importantly, it reduces the possibility of interference to neighboring equipment. The EMI performance of an enclosure using these transceivers is dependent on the chassis design. Agilent encourages using standard RF suppression practices and avoiding poorly EMI-sealed enclosures.

Absolute Maximum Ratings

Stresses in excess of the absolute maximum ratings can cause catastrophic damage to the device. Limits apply to each parameter in isolation, all other parameters having values within the recommended operating conditions. It should not be assumed that limiting values of more than one parameter can be applied to the product at the same time. Exposure to the absolute maximum ratings for extended periods can adversely affect device reliability.

Parameter	Symbol	Min.	Typ.	Max.	Unit	Reference
Storage Temperature	T_s	-40		+100	°C	
Supply Voltage	V_{CC}	-0.5		7.0	V	1
Data Input Voltage	V_I	-0.5		V_{CC}	V	
Transmitter Differential Input Voltage	V_D			1.6	V	2
Output Current	I_o			50	mA	
Relative Humidity	RH	5		95	%	

Recommended Operating Conditions

Parameter	Symbol	Min.	Typ.	Max.	Unit	Reference
Ambient Operating Temperature	T_A	0		+70	°C	
Case Temperature	T_C			+90	°C	3
Supply Voltage	V_{CC}	4.75		5.25	V	
Power Supply Rejection	PSR		50		mV _{P-P}	4
Transmitter Differential Input Voltage	V_D	0.3		1.6	V	
Data Output Load	R_{DL}	50			Ω	5
Signal Detect Output Load	R_{SDL}	50			Ω	5

Process Compatibility

Parameter	Symbol	Min.	Typ.	Max.	Unit	Reference
Hand Lead Soldering Temperature/Time	T_{SOLD}/t_{SOLD}			+260/10	°C/sec	
Wave Soldering and Aqueous Wash	T_{SOLD}/t_{SOLD}			+260/10	°C/sec	6

Notes:

1. The transceiver is class 1 eye-safe up to $V_{CC} = 7 V$.
2. This is the maximum voltage that can be applied across the Differential Transmitter Data Inputs without damaging the input circuit.
3. Case temperature measurement referenced to the center-top of the internal metal transmitter shield.
4. Tested with a 50 mV_{P-P} sinusoidal signal in the frequency range from 500 Hz to 1500 kHz on the V_{CC} supply with the recommended power supply filter in place. Typically less than a 0.25 dB change in sensitivity is experienced.
5. The outputs are terminated to $V_{CC} - 2 V$.
6. Aqueous wash pressure < 110 psi.

HFBR-53B3 Family, 850 nm VCSEL

Transmitter Electrical Characteristics

($T_A = 0^\circ\text{C}$ to $+70^\circ\text{C}$, $V_{CC} = 4.75\text{ V}$ to 5.25 V)

Parameter	Symbol	Min.	Typ.	Max.	Unit	Reference
Supply Current	I_{CCT}		85	120	mA	
Power Dissipation	P_{DIST}		0.45	0.63	W	
Data Input Current - Low	I_{IL}	-350	0		μA	
Data Input Current - High	I_{IH}		16	350	μA	
Laser Reset Voltage	$V_{CCT-reset}$		2.7	2.5	V	1

Receiver Electrical Characteristics

($T_A = 0^\circ\text{C}$ to $+70^\circ\text{C}$, $V_{CC} = 4.75\text{ V}$ to 5.25 V)

Parameter	Symbol	Min.	Typ.	Max.	Unit	Reference
Supply Current	I_{CCR}		105	130	mA	
Power Dissipation	P_{DISR}		0.53	0.68	W	2
Data Output Voltage - Low	$V_{OL} - V_{CC}$	-1.950		-1.620	V	3
Data Output Voltage - High	$V_{OH} - V_{CC}$	-1.045		-0.740	V	3
Data Output Rise Time	t_r			0.40	ns	4
Data Output Fall Time	t_f			0.40	ns	4
Signal Detect Output Voltage - Low	$V_{OL} - V_{CC}$	-1.950		-1.620	V	3
Signal Detect Output Voltage - High	$V_{OH} - V_{CC}$	-1.045		-0.740	V	3

Notes:

1. The Laser Reset Voltage is the voltage level below which the V_{CCT} voltage must be lowered to cause the laser driver circuit to reset from an electrical/optical shutdown condition to a proper electrical/optical operating condition. The maximum value corresponds to the worst-case highest V_{CC} voltage necessary to cause a reset condition to occur. The laser safety shutdown circuit will operate properly with transmitter V_{CC} levels of 3.5 Vdc \leq V_{CC} \leq 7.0 Vdc.
2. Power dissipation value is the power dissipated in the receiver itself. It is calculated as the sum of the products of V_{CC} and I_{CC} minus the sum of the products of the output voltages and currents.
3. These outputs are compatible with 10 K, 10 KH, and 100 K ECL and PECL inputs.
4. These are 20-80% values.

HFBR-53B3 Family, 850 nm VCSEL

Transmitter Optical Characteristics

($T_A = 0^\circ\text{C}$ to $+70^\circ\text{C}$, $V_{CC} = 4.75\text{ V}$ to 5.25 V)

Parameter	Symbol	Min.	Typ.	Max.	Unit	Reference
Output Optical Power	P_{OUT}	-9.5		-4	dBm avg.	1
50/125 μm , NA = 0.20 Fiber						
Output Optical Power	P_{OUT}	-9.5		-4	dBm avg.	1
62.5/125 μm , NA = 0.275 Fiber						
Optical Extinction Ratio		9			dB	2
Center Wavelength	λ_c	830	850	860	nm	
Spectral Width - rms	s			0.85	nm rms	
Optical Rise/Fall Time	t_r/t_f			0.26	ns	3, 4 Figure 1
RIN_{12}				-116	dB/Hz	
Coupled Power Ratio	CPR	9			dB	5
Total Transmitter Jitter				227	ps	6
Added at TP2						

Receiver Optical Characteristics

($T_A = 0^\circ\text{C}$ to $+70^\circ\text{C}$, $V_{CC} = 4.75\text{ V}$ to 5.25 V)

Parameter	Symbol	Min.	Typ.	Max.	Unit	Reference
Input Optical Power	P_{IN}	-17		0	dBm avg.	7
Stressed Receiver Sensitivity	62.5 μm			-12.5	dBm avg.	8
	50 μm			-13.5	dBm avg.	8
Stressed Receiver Eye		201			ps	6,9
Opening at TP4						
Receive Electrical 3 dB				1500	MHz	10
Upper Cutoff Frequency						
Operating Center Wavelength	λ_c	770		860	nm	
Return Loss		12			dB	11
Signal Detect – Asserted	P_A			-18	dBm avg.	
Signal Detect – Deasserted	P_D	-30			dBm avg.	
Signal Detect – Hysteresis	$P_A - P_D$	1.5			dB	

Notes:

1. The maximum Optical Output Power complies with the IEEE 802.3z specification, and is class 1 laser eye safe.
2. Optical Extinction Ratio is defined as the ratio of the average output optical power of the transmitter in the high ("1") state to the low ("0") state. The transmitter is driven with a Gigabit Ethernet 1250 MBd 8B/10B encoded serial data pattern. This Optical Extinction Ratio is expressed in decibels (dB) by the relationship $10\log(P_{\text{high avg}}/P_{\text{low avg}})$.
3. These are unfiltered 20-80% values.
4. Laser transmitter pulse response characteristics are specified by an eye diagram (Figure 1). The characteristics include rise time, fall time, pulse overshoot, pulse undershoot, and ringing, all of which are controlled to prevent excessive degradation of the receiver sensitivity. These parameters are specified by the referenced Gigabit Ethernet eye diagram using the required filter. The output optical waveform complies with the requirements of the eye mask discussed in section 38.6.5 and Fig. 38-2 of IEEE 802.3z.
5. CPR is measured in accordance with EIA/TIA-526-14A as referenced in 802.3z, section 38.6.10.
6. TP refers to the compliance point specified in 802.3z, section 38.2.1.
7. The receive sensitivity is measured using a worst case extinction ratio penalty while sampling at the center of the eye.
8. The stressed receiver sensitivity is measured using the conformance test signal defined in 802.3z, section 38.6.11. The conformance test signal is conditioned by applying deterministic jitter and intersymbol interference.
9. The stressed receiver jitter is measured using the conformance test signal defined in 802.3z, section 38.6.11 and set to an average optical power 0.5 dB greater than the specified stressed receiver sensitivity.
10. The 3 dB electrical bandwidth of the receiver is measured using the technique outlined in 802.3z, section 38.6.12.
11. Return loss is defined as the minimum attenuation (dB) of received optical power for energy reflected back into the optical fiber.

Table 1. Pinout Table

Pin	Symbol	Functional Description
Mounting Pins		The mounting pins are provided for transceiver mechanical attachment to the circuit board. They are embedded in the nonconductive plastic housing and are not connected to the transceiver internal circuit, nor is there a guaranteed connection to the metallized housing in the EM and FM versions. They should be soldered into plated-through holes on the printed circuit board.
1	V_{EER}	Receiver Signal Ground Directly connect this pin to receiver signal ground plane. (For HFBR-5B3, $V_{EER} = V_{EET}$).
2	RD+	Receiver Data Out RD+ is an open emitter output circuit. Termination is done externally to the module.
3	RD-	Receiver Data Out Bar RD- is an open emitter output circuit. Termination is done externally to the module.
4	SD	Signal Detect Normal optical input levels to the receiver result in a logic "1" output, V_{OH} , asserted. Low input optical levels to the receiver result in a fault condition indicated by a logic "0" output, V_{OL} , deasserted. Signal Detect is a single-ended PECL output. SD can be terminated with standard PECL techniques via 50Ω to $V_{CCR}-2V$. Alternatively, SD can be loaded with a 270Ω resistor to V_{EER} to conserve electrical power with small compromise to signal integrity. If Signal Detect is not used, leave it open circuited. This Signal Detect output can be used to drive a PECL input on an upstream circuit, such as, Signal Detect input or Loss of Signal-bar.
5	V_{CCR}	Receiver Power Supply Provide +5 V dc via the recommended receiver power supply filter circuit. Locate the power supply filter circuit as close as possible to the V_{CCR} pin.
6	V_{CCT}	Transmitter Power Supply Provide +5 V dc via the recommended transmitter power supply filter circuit. Locate the power supply filter circuit as close as possible to the V_{CCT} pin.
7	TD-	Transmitter Data In-Bar AC coupled - PECL compatible. Internally terminated differentially with 100Ω .
8	TD+	Transmitter Data In AC coupled - PECL compatible. Internally terminated differentially with 100Ω .
9	V_{EET}	Transmitter Signal Ground Directly connect this pin to the transmitter signal ground plane.

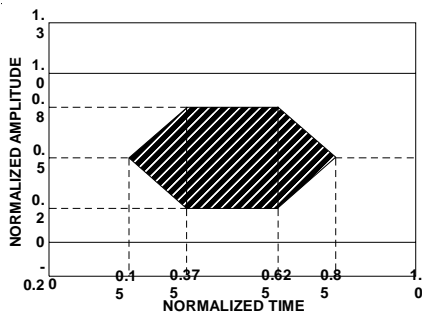

Figure 1. Transmitter optical eye diagram mask.

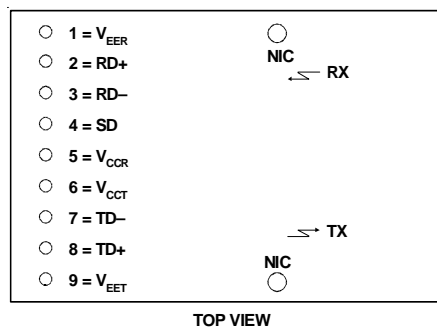
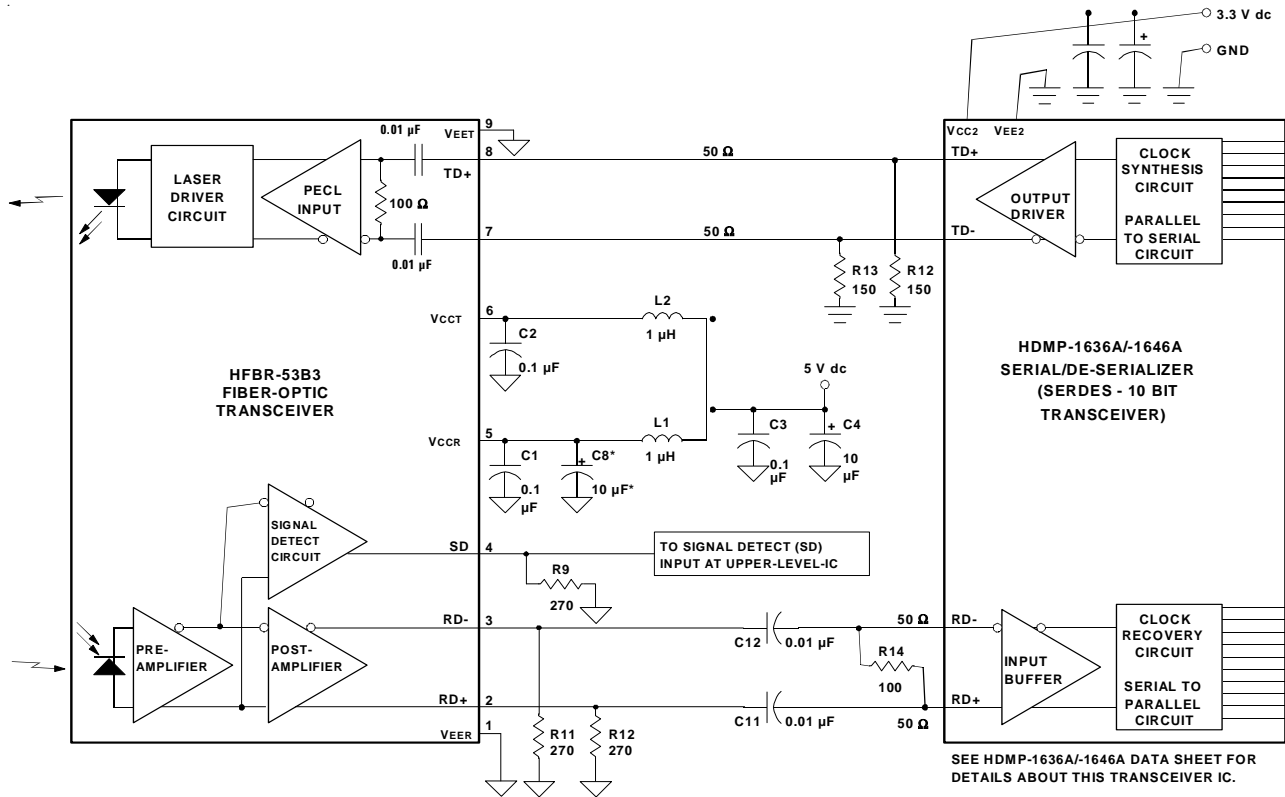

Figure 2. Pin-out.



NOTES:
 *C8 IS AN OPTIONAL BYPASS CAPACITOR FOR ADDITIONAL LOW-FREQUENCY NOISE FILTERING.
 USE SURFACE-MOUNT COMPONENTS FOR OPTIMUM HIGH-FREQUENCY PERFORMANCE.
 USE 50 Ω MICROSTRIP OR STRIPLINE FOR SIGNAL PATHS.
 LOCATE 50 Ω TERMINATIONS AT THE INPUTS OF RECEIVING UNITS.

Figure 3. Recommended Gigabit/sec Ethernet HFBR-53B3 Fiber-Optic Transceiver and HDMP-1636A/1646A SERDES Integrated Circuit Transceiver Interface and Power Supply Filter Circuits.

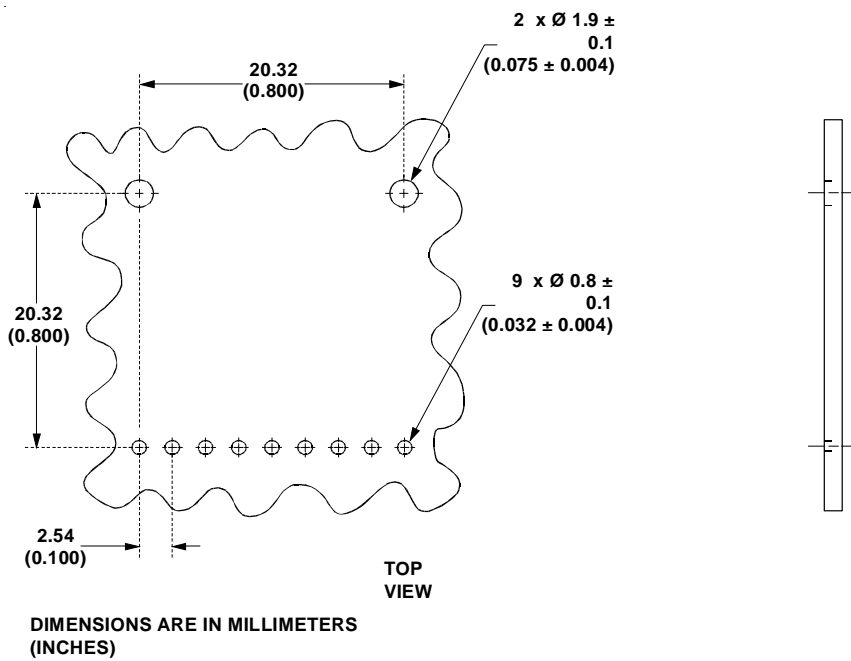
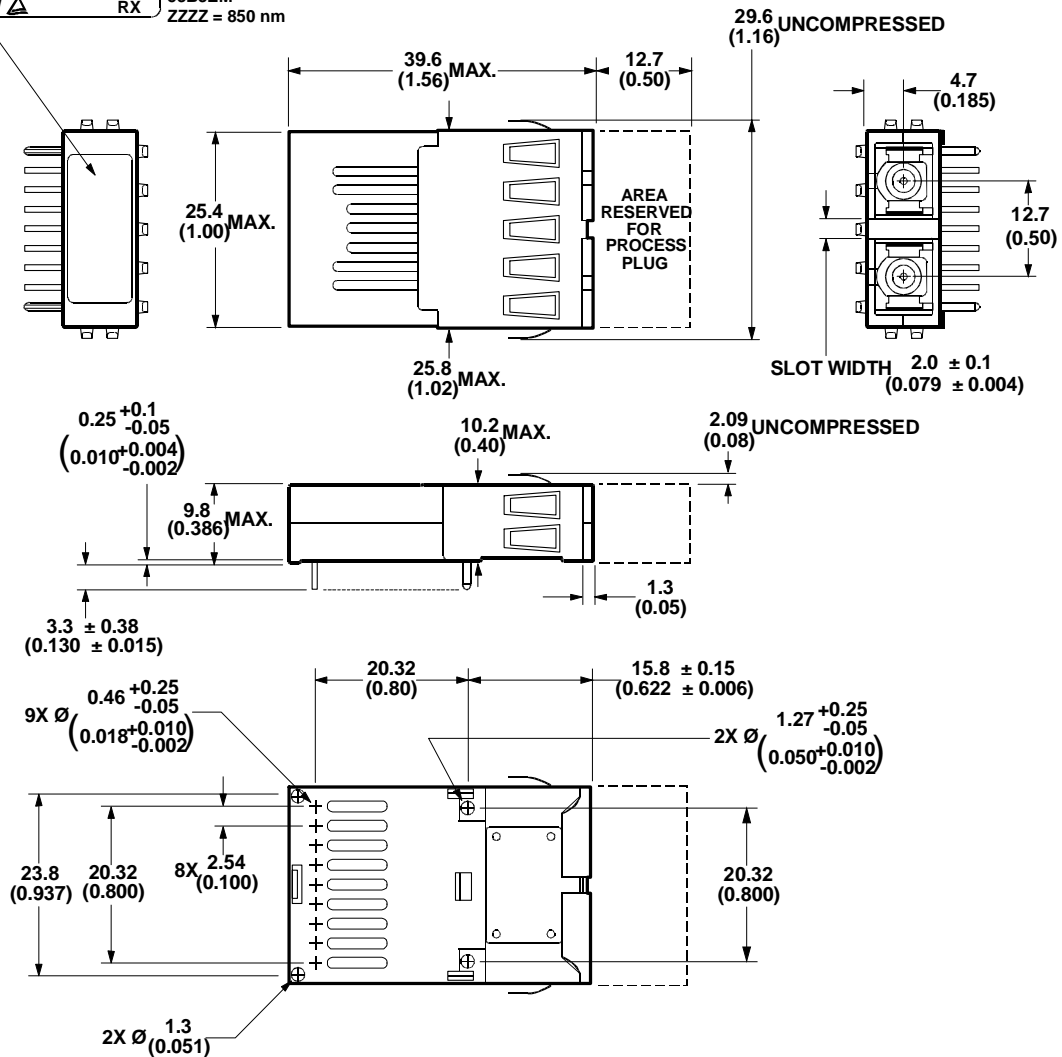

Figure 4. Recommended Board Layout Hole Pattern.

Agilent
 XXXX-XXXX
 ZZZZ LASER PROD
 21CFR(J) CLASS 1
 COUNTRY OF ORIGIN
 YYWW
 TX RX

KEY:
 YYWW = DATE CODE
 XXXX-XXXX = HFBR-
 53B3EM
 ZZZZ = 850 nm



DIMENSIONS ARE IN MILLIMETERS (INCHES).
 ALL DIMENSIONS ARE ±0.025 mm UNLESS OTHERWISE SPECIFIED.

Figure 5. Package outline for HFBR-53B3EM.

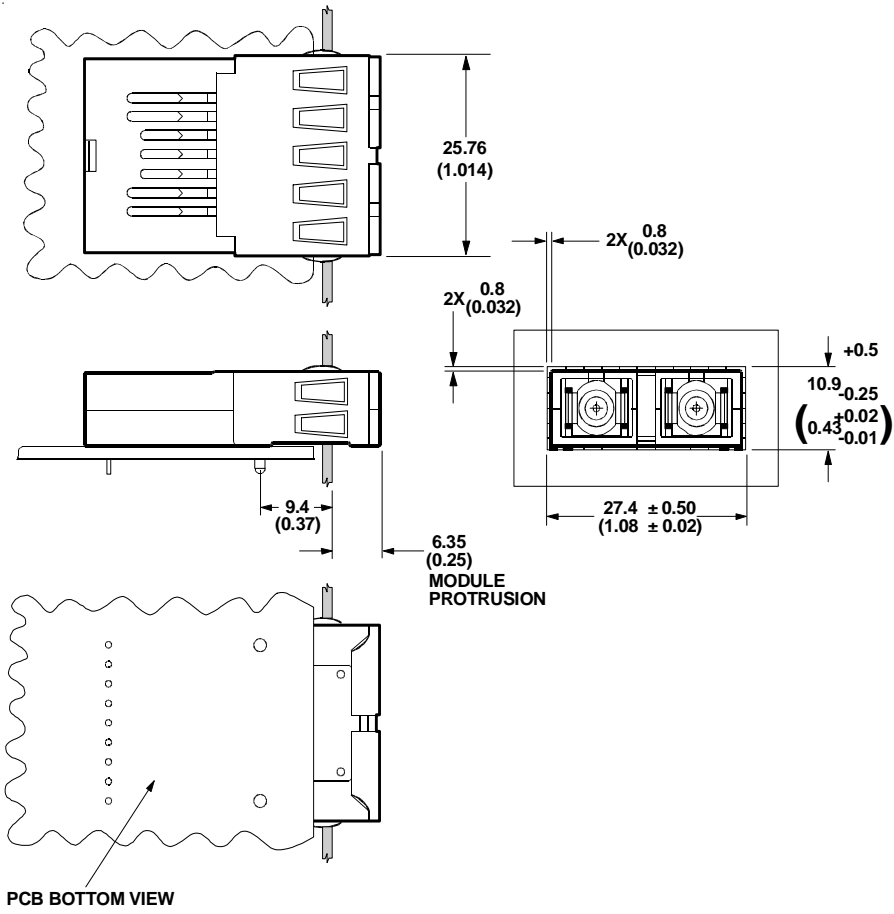
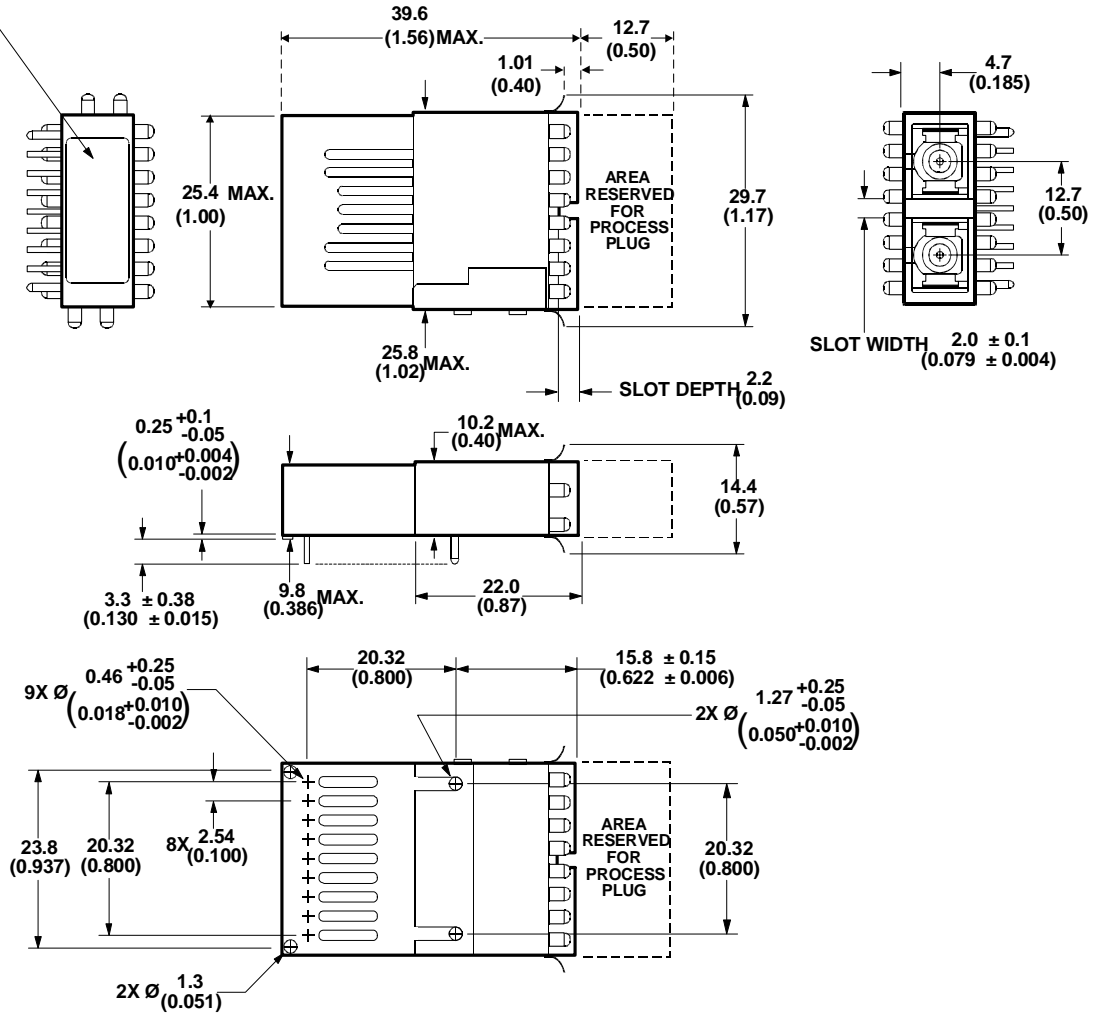

Figure 6. Suggested module positioning and panel cut-out for HFBR-53B3EM.

Agilent
 TX XXXX-XXXX
 ZZZZ LASER PROD
 21CFR(J) CLASS 1
 COUNTRY OF ORIGIN
 RX YYWW

KEY:
 YYWW = DATE CODE
 XXXX-XXXX = HFBR-
 53B3FM
 ZZZZ = 850 nm



DIMENSIONS ARE IN MILLIMETERS (INCHES).
 ALL DIMENSIONS ARE ± 0.025 mm UNLESS OTHERWISE SPECIFIED.

Figure 7. Package outline for HFBR-53B3FM.

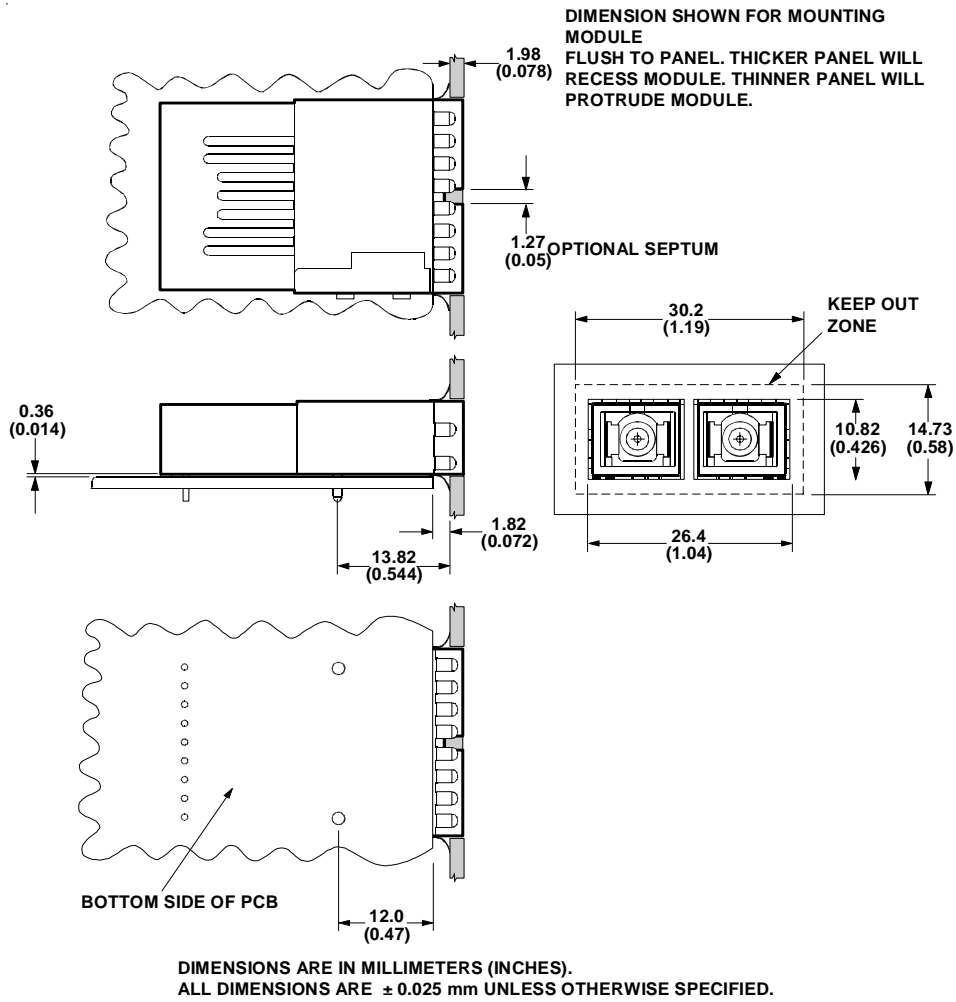

Figure 8. Suggested module positioning and panel cut-out for HFBR-53B3FM.

Ordering Information

850 nm VCSEL	(SX – Short Wavelength Laser)
HFBR-53B3EM	Extended shield, metal housing.
HFBR-53B3FM	Flush shield, metal housing.

**[www.agilent.com/
semiconductors](http://www.agilent.com/semiconductors)**

For product information and a complete list of distributors, please go to our web site.

For technical assistance call:

Americas/Canada: +1 (800) 235-0312 or
(916) 788-6763

Europe: +49 (0) 6441 92460

China: 10800 650 0017

Hong Kong: (+65) 271 2451

India, Australia, New Zealand: (+65) 271 2394

Japan: (+81 3) 3335-8152(Domestic/International), or
0120-61-1280(Domestic Only)

Korea: (+65) 271 2194

Malaysia, Singapore: (+65) 271 2054

Taiwan: (+65) 271 2654

Data subject to change.

Copyright © 2004 Agilent Technologies, Inc.

Obsoletes: 5988-7029EN

January 23, 2004

5989-0209EN



Agilent Technologies