

Features

- 1W Power Dissipation on FR-4 PCB
- **Lead Free Finish, RoHS Compliant (Note 2)**
- **"Green" Molding Compound (No Br, Sb)**
- **Qualified to AEC-Q101 Standards for High Reliability**

Mechanical Data

- Case: PowerDI®123
- Case Material: Molded Plastic, "Green" Molding Compound. UL Flammability Classification Rating 94V-0
- Moisture Sensitivity: Level 1 per J-STD-020D
- Terminal Connections: Cathode Band
- Terminals: Finish - Matte Tin annealed over Copper leadframe. Solderable per MIL-STD-202, Method 208⁽³⁾
- Marking Information: See Page 3
- Ordering Information: See Page 3
- Weight: 0.01 grams (approximate)



Top View

Maximum Ratings @ $T_A = 25^\circ\text{C}$ unless otherwise specified

Characteristic	Symbol	Value	Unit
Forward Voltage @ $I_F = 200\text{mA}$	V_F	1.2	V

Thermal Characteristics

Characteristic	Symbol	Typ	Value	Unit
Power Dissipation (Note 1)	P_D	—	1.0	W
Thermal Resistance Junction to Ambient Air (Note 1)	$R_{\theta JA}$	110	—	$^\circ\text{C/W}$
Thermal Resistance Junction to Soldering Point (Note 3)	$R_{\theta JS}$	—	9	$^\circ\text{C/W}$
Operating and Storage Temperature Range	T_J, T_{STG}	—	-55 to +150	$^\circ\text{C}$

- Notes:
1. Device mounted on 1" x 1", FR-4 PCB; 2 oz. Cu pad layout as shown on Diodes Inc. suggested pad layout document AP02001.pdf.
 2. EU Directive 2002/95/EC (RoHS). All applicable RoHS exemptions applied, see *EU Directive 2002/95/EC Annex Notes*.
 3. Theoretical $R_{\theta JS}$ calculated from the top center of the die straight down to the PCB/cathode tab solder junction.

Electrical Characteristics @ $T_A = 25^\circ\text{C}$ unless otherwise specified

Type Number	Marking Codes	Zener Voltage Range (Note 4)				Zener Impedance		Maximum Reverse Current (Note 4)		Typical Temperature Coefficient @ I_{ZT} %/°C	
		$V_Z @ I_{ZT}$			I_{ZT}	$Z_{ZT} @ I_{ZT}$		I_R	@ V_R	Min	Max
		Nom (V)	Min (V)	Max (V)	mA	Typ (Ω)	Max (Ω)	μA	V		
DFLZ5V1	FHK	5.1	4.8	5.4	100	2	6	2.5	1	-0.08	-0.2
DFLZ5V6	FHL	5.6	5.2	6.0	100	1	4	10	2	-0.04	0.04
DFLZ6V2	FHN	6.2	5.8	6.6	100	1	3	5	2	-0.01	0.06
DFLZ6V8	FHO	6.8	6.4	7.2	100	1	3	5	3	0	0.07
DFLZ7V5	FHQ	7.5	7.0	7.9	100	1	2	5	3	0	0.07
DFLZ8V2	FHR	8.2	7.7	8.7	100	1	2	5	3	0.03	0.08
DFLZ9V1	FHT	9.1	8.5	9.6	50	1	4	5	5	0.03	0.08
DFLZ10	FHU	10	9.4	10.6	50	1	4	5	7.5	0.05	0.09
DFLZ11	FHV	11	10.4	11.6	50	1	7	4	8.2	0.05	0.10
DFLZ12	FHW	12	11.4	12.7	50	1	7	3	9.1	0.05	0.10
DFLZ13	FHX	13	12.4	14.1	50	1	10	2	10	0.05	0.10
DFLZ15	FHZ	15	13.8	15.6	50	1	10	1	11	0.05	0.10
DFLZ16	FJA	16	15.3	17.1	25	1	15	1	12	0.06	0.11
DFLZ18	FJF	18	16.8	19.1	25	2	15	1	13	0.06	0.11
DFLZ20	FJG	20	18.8	21.2	25	3	15	1	15	0.06	0.11
DFLZ22	FJK	22	20.8	23.3	25	3	15	1	16	0.06	0.11
DFLZ24	FJL	24	22.8	25.6	25	2	15	1	18	0.06	0.11
DFLZ27	FJN	27	25.1	28.9	25	3	15	1	20	0.06	0.11
DFLZ30	FJQ	30	28	32	25	8	15	1	22	0.06	0.11
DFLZ33	FJR	33	31	35	25	5	15	1	24	0.06	0.11
DFLZ36	FJS	36	34	38	10	5	40	1	27	0.06	0.11
DFLZ39	FJT	39	37	41	10	5	40	1	30	0.06	0.11

Notes: 4. Short duration pulse test used to minimize self-heating effect.

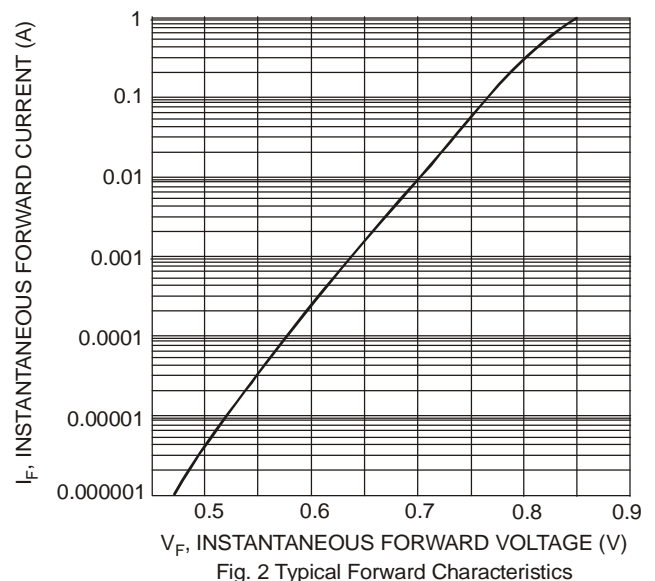
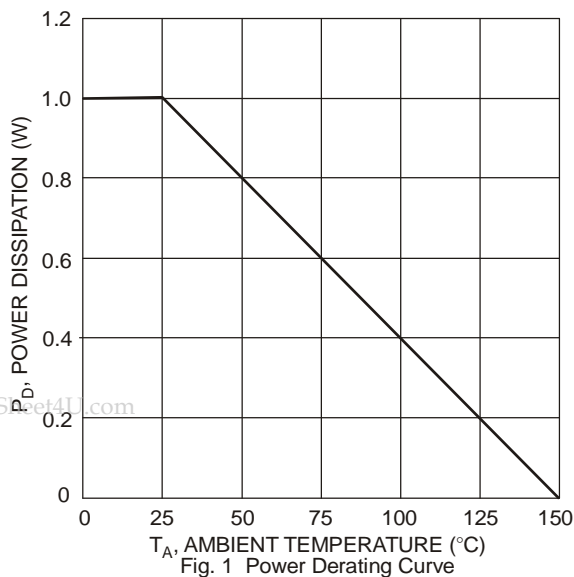

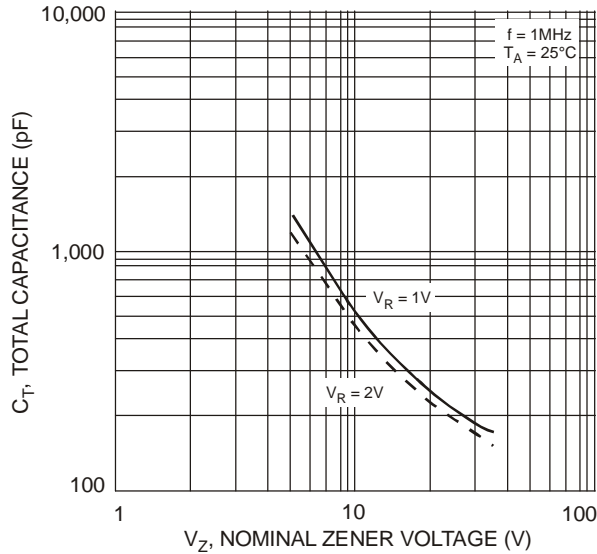

Fig. 3 Typical Total Capacitance vs. Nominal Zener Voltage

Ordering Information (Note 5)

Device	Packaging	Shipping
(Type Number)-7*	PowerDI [®] 123	3000/Tape & Reel

* Add "-7" to the appropriate type number in Electrical Characteristics Table. Example: 6.2V Zener = DFLZ6V2-7

 Notes: 5. For packaging details, go to our website at <http://www.diodes.com/datasheets/ap02007.pdf>.

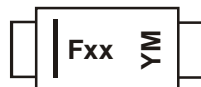
Marking Information

Fxx = Product Type Marking Code
 (See Electrical Characteristics Table)
 YM = Date Code Marking
 Y = Year (ex: R = 2004)
 M = Month (ex: 9 = September)

Date Code Key

Year	2004	2005	2006	2007	2008	2009	2010	2011	2012
Code	R	S	T	U	V	W	X	Y	Z

Month	Jan	Feb	Mar	Apr	May	Jun	Jul	Aug	Sep	Oct	Nov	Dec
Code	1	2	3	4	5	6	7	8	9	O	N	D

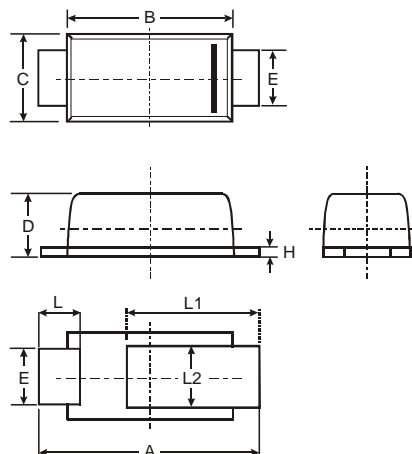
Package Outline Dimensions

PowerDI [®] 123			
Dim	Min	Max	Typ
A	3.50	3.90	3.70
B	2.60	3.00	2.80
C	1.63	1.93	1.78
D	0.93	1.00	0.98
E	0.85	1.25	1.00
H	0.15	0.25	0.20
L	0.55	0.75	0.65
L1	1.80	2.20	2.00
L2	0.95	1.25	1.10

All Dimensions in mm

www.DataSheet4U.com

PowerDI is a registered trademark of Diodes Incorporated.

DFLZ5V1 - DFLZ39

Document number: DS30464 Rev. 8 - 2

3 of 4

www.diodes.com
www.DataSheet4U.com

January 2009

© Diodes Incorporated

Suggested Pad Layout

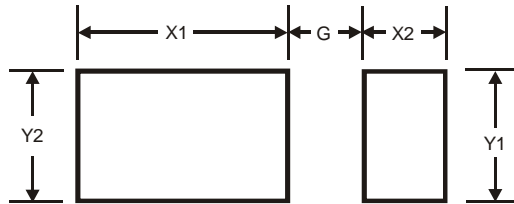

Dimensions	Value (in mm)
G	1.0
X1	2.2
X2	0.9
Y1	1.4
Y2	1.4

IMPORTANT NOTICE

Diodes Incorporated and its subsidiaries reserve the right to make modifications, enhancements, improvements, corrections or other changes without further notice to any product herein. Diodes Incorporated does not assume any liability arising out of the application or use of any product described herein; neither does it convey any license under its patent rights, nor the rights of others. The user of products in such applications shall assume all risks of such use and will agree to hold Diodes Incorporated and all the companies whose products are represented on our website, harmless against all damages.

LIFE SUPPORT

Diodes Incorporated products are not authorized for use as critical components in life support devices or systems without the expressed written approval of the President of Diodes Incorporated.