

SMD Power Inductor CDRH10D38D/HP



Halogen
Free



Description

- Ferrite drum core construction
- Magnetically shielded
- L × W × H: 10.3 × 10.3 × 4.0 mm Max.
- Product weight: 1.35g(Ref.)
- Moisture Sensitivity Level: 1
- RoHS compliance.
- Halogen Free available.

Environmental Data

- Operating temperature range: -40°C~+105°C (including coil's self temperature rise)
- Storage temperature range: -40°C~+105°C
- Solder reflow temperature: 260 °C peak.

Packaging

- Carrier tape and reel packaging

Applications

- Ideally used in LCD TV and Note PC.

Dimension - [mm]

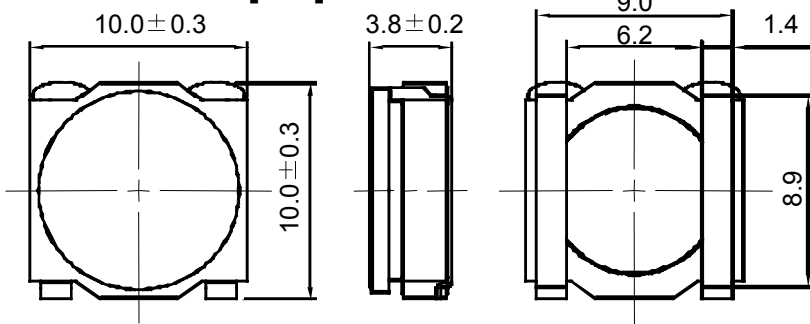

Land pattern and Schematics - [mm]

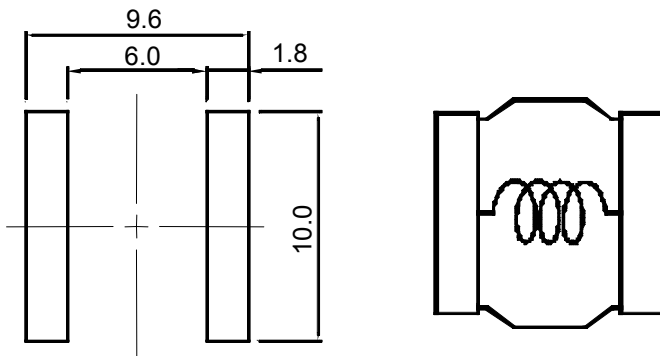



Electrical Characteristics

PART NAME	STAMP	INDUCTANCE [WITHIN] (100kHz)	D.C.R. (mΩ) (at 20°C)	SATURATION CURRENT (A)※1 (at 20°C)	TEMPERATURE RISE CURRENT(A) ※2
CDRH10D38DHPNP-R82PC	R82	0.82±25%	4.0±25%	18.30	12.00
CDRH10D38DHPNP-1R5PC	1R5	1.5±25%	6.5±25%	13.75	9.50
CDRH10D38DHPNP-2R2PC	2R2	2.2±25%	9.0±25%	11.20	8.40
CDRH10D38DHPNP-3R3PC	3R3	3.3±25%	13.5±25%	9.25	6.50
CDRH10D38DHPNP-4R7PC	4R7	4.7±25%	16.0±25%	7.65	5.80
CDRH10D38DHPNP-6R2MC	6R2	6.2±20%	20.5±25%	6.65	5.30
CDRH10D38DHPNP-100MC	100	10±20%	33.0±25%	5.20	4.00
CDRH10D38DHPNP-150MC	150	15±20%	52±25%	4.20	3.10
CDRH10D38DHPNP-220MC	220	22±20%	74±25%	3.55	2.55
CDRH10D38DHPNP-330MC	330	33±20%	116±20%	3.90	2.00
CDRH10D38DHPNP-470MC	470	47±20%	173±20%	2.40	1.60
CDRH10D38DHPNP-680MC	680	68±20%	225±20%	2.05	1.40
CDRH10D38DHPNP-101MC	101	100±20%	332±20%	1.60	1.15
CDRH10D38DHPNP-151MC	151	150±20%	445±20%	1.35	1.00
CDRH10D38DHPNP-221MC	221	220±20%	645±20%	1.10	0.85
CDRH10D38DHPNP-331MC	331	330±20%	995±20%	0.90	0.64

※1. Saturation current: The value of D.C. current when the inductance decreases to 70% of it's nominal value.

※2. Temperature rise current: The value of D.C. current when the temperature rise is $\Delta t=40^{\circ}\text{C}$ ($T_a=20^{\circ}\text{C}$).

SMD Power Inductor CDRH10D38D/HP

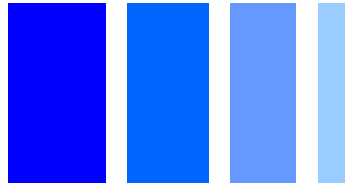

Saturation Current & Temperature Rise Graph

— L (20°C) — L (105°C) — ΔT

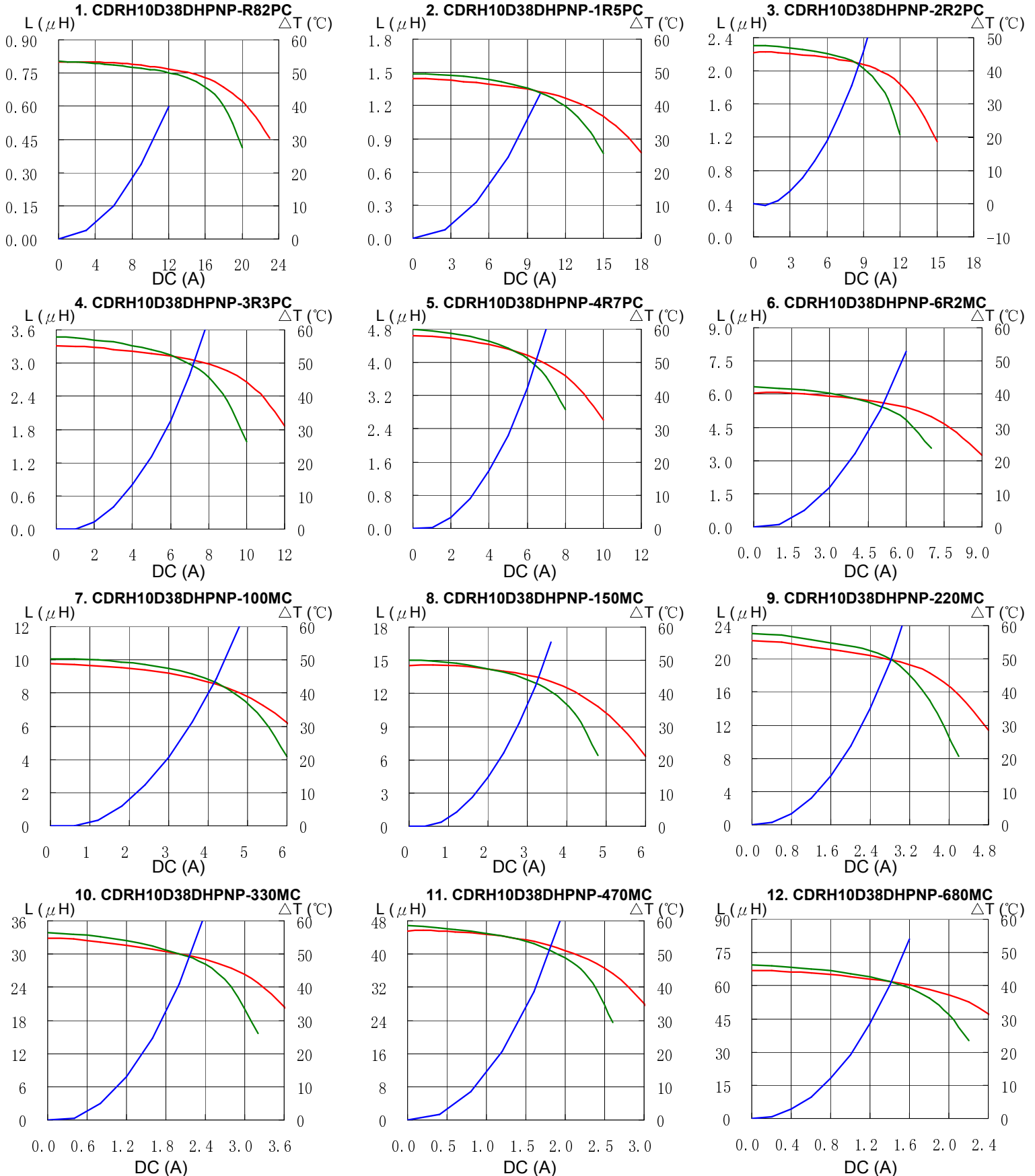

SMD Power Inductor CDRH10D38D/HP



Saturation Current & Temperature Rise Graph

— L (20°C) — L (105°C) — ΔT

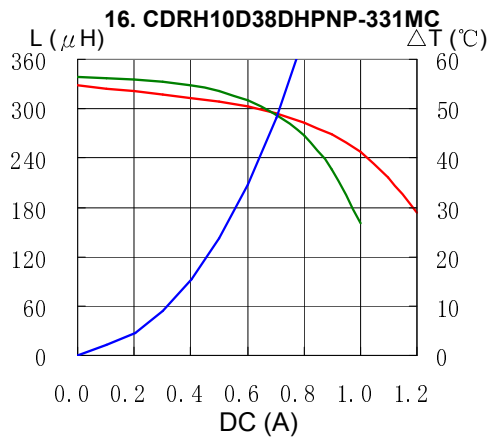
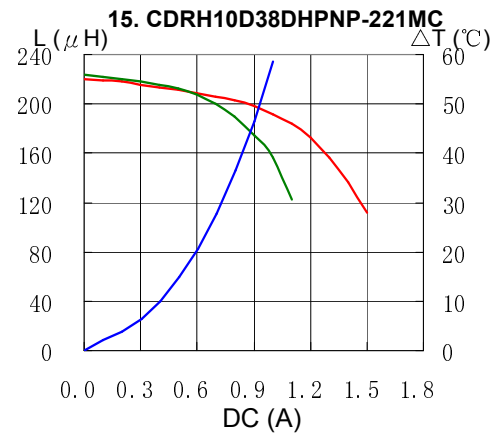
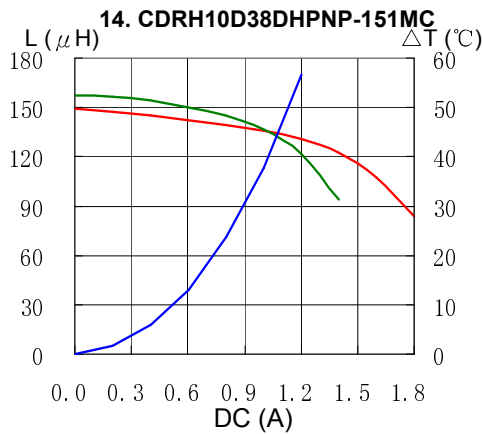
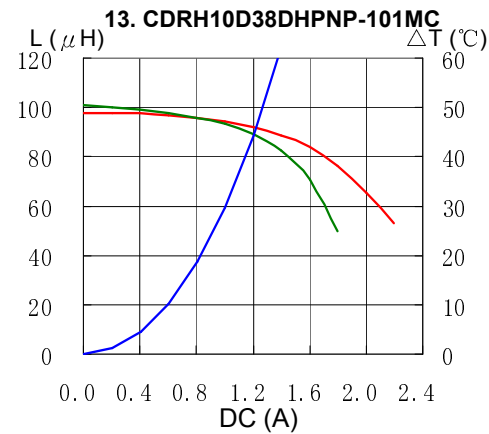

Solder Reflow Condition

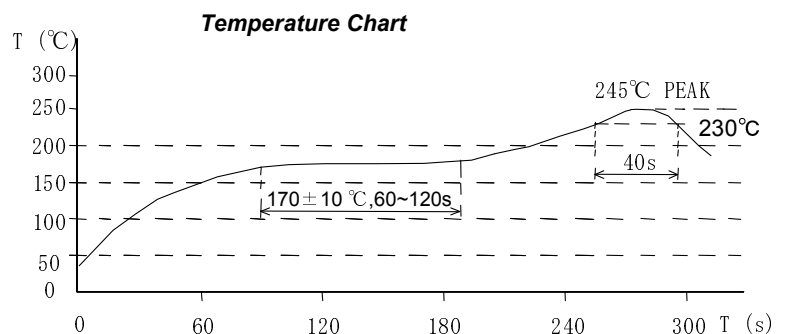
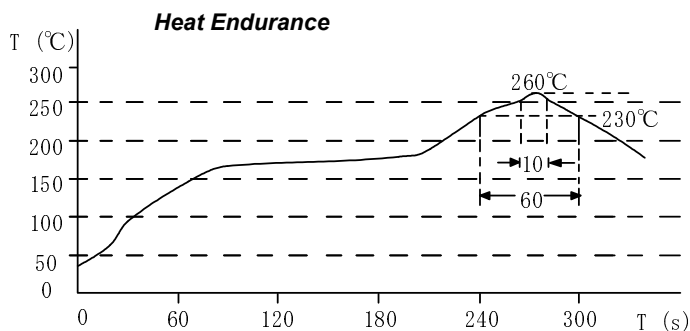

Please refer to the sales offices on our website - <http://www.sumida.com>

Hong Kong

Tel.+852-2880-6688
FAX.+852-2565-9600
sales@hk.sumida.com

Tokyo

Tel.+81-3-5202-7112
FAX.+81-3-5202-7105
sales@jp.sumida.com

Chicago

Tel.+1-847-545-6700
FAX. +1-847-545-6720
sales@us.sumida.com

Shanghai

Tel.+86-021-5836-3299
FAX.+86-021-5836-3266
shanghai.sales@cn.sumida.com

Seoul

Tel.+82-2-6237-0777
FAX.+82-2-6237-0778
sales@kr.sumida.com

Obernzell

Tel.+49-8591-937-0
FAX. +49-8591-937-103
contact@sumida-eu.com

Shenzhen

Tel.+86-755-8291-0228
FAX.+86-755-8291-0338
shenzhen.sales@cn.sumida.com

Singapore

Tel.+65-6296-3388
FAX.+65-6296-3390
sales@sg.sumida.com

Neumarkt

Tel.+49-9181-4509-110
FAX. +49-9181-4509-310
infocomp@eu.sumida.com

Taipei

Tel.+886-2-8751-2737
FAX.+886-2-8751-2738
sales@tw.sumida.com

San Jose

Tel.+1-408-3219660
FAX.+1-408-321-9308
sales@us.sumida.com