

# SKR 12,4 Qu bond



**DIODE**

$$I_{F(DC)} = 235 \text{ A}$$

$$V_{RRM} = 1600 \text{ V}$$

Size: 12,4 mm x 12,4 mm

## SKR 12,4 Qu bond

### Features

- high current density due to mesa technology
- high surge current
- compatible to thick wire bonding
- compatible to all standard solder processes

### Typical Applications

- uncontrolled rectifier bridges

Absolute Maximum Ratings			
Symbol	Conditions	Values	Unit
$V_{RRM}$	$T_j = 25 \text{ }^\circ\text{C}$ , $I_R = 0.2 \text{ mA}$	1600	V
$I_{F(AV)}$	$T_s = 80 \text{ }^\circ\text{C}$ , $T_j = 150 \text{ }^\circ\text{C}$	190	A
$I^2t$	$T_j = 150 \text{ }^\circ\text{C}$ , 10 ms, sin 180°	26450	A <sup>2</sup> s
$I_{FSM}$	10 ms	$T_j = 25 \text{ }^\circ\text{C}$	3200
	sin 180°	$T_j = 150 \text{ }^\circ\text{C}$	2300
$T_{jmax}$		150	°C

Electrical Characteristics					
Symbol	Conditions	min.	typ.	max.	Unit
$I_R$	$T_j = 25 \text{ }^\circ\text{C}$ , $V_{RRM}$			0.2	mA
	$T_j = 120 \text{ }^\circ\text{C}$ , $V_{RRM}$			1.1	mA
$V_F$	$T_j = 25 \text{ }^\circ\text{C}$ , $I_F = 160 \text{ A}$		1	1.21	V
	$T_j = 125 \text{ }^\circ\text{C}$ , $I_F = 160 \text{ A}$		0.9	1.1	V
$V_{(TO)}$	$T_j = 125 \text{ }^\circ\text{C}$			0.83	V
$r_T$	$T_j = 125 \text{ }^\circ\text{C}$			1.0	mΩ
$t_{rr}$	$T_j = 25 \text{ }^\circ\text{C}$ , ± 1 A		34		μs

Thermal Characteristics					
Symbol	Conditions	min.	typ.	max.	Unit
$T_j$		-40		150	°C
$T_{stg}$		-40		150	°C
$T_{solder}$	10 min.			250	°C
$T_{solder}$	5 min.			320	°C
$R_{th(j-s)}$	soldered on 0,38 mm DCB, reference point on copper heatsink close to the chip		0.27		K/W

Mechanical Characteristics			
Symbol	Conditions	Values	Unit
Raster size		12,4 x 12,4	mm
Area total		153,76	mm <sup>2</sup>
Anode		bondable (Al)	
Cathode		solderable (Ag/Ni)	
Wire bond		Al, diameter ≤ 500 μm	
Package		tray	
Chips / Package		36	pcs

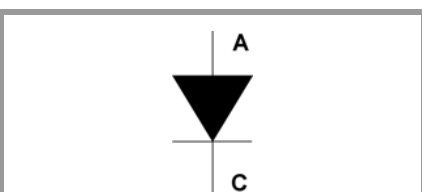

**SKR**

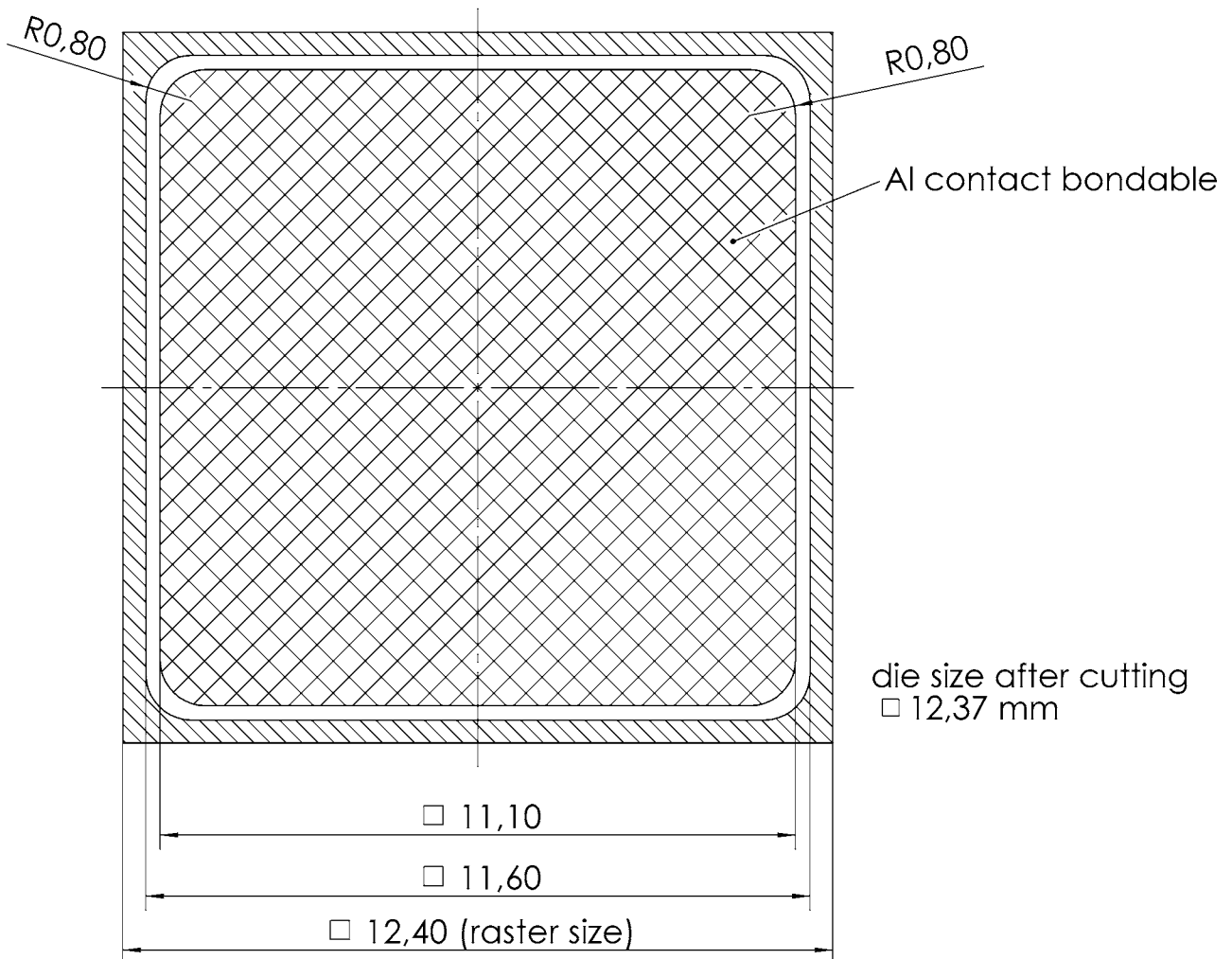
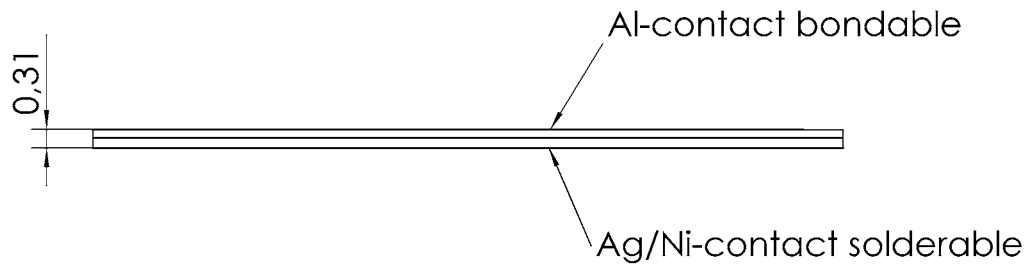

This technical information specifies semiconductor devices. No warranty or guarantee expressed or implied is made regarding delivery, performance or suitability.