

SBH 1220TL ... SBH 1245TL

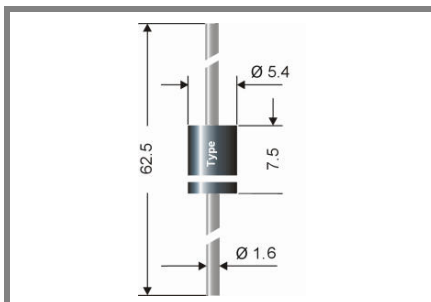

Axial lead diode

Type	Repetitive peak reverse voltage V_{RRM} V	Surge peak reverse voltage V_{RSM} V	Max. reverse recovery time $I_F = -A$ $I_R = -A$ $I_{RR} = -A$ t_{rr} ns	Max. forward voltage $V_F^{2)}$
SBH 1220TL	20	20	-	0,51
SBH 1230TL	30	30	-	0,51
SBH 1240TL	40	40	-	0,51
SBH 1245TL	45	45	-	0,51

High temperature Schottky barrier diodes

SBH 1220TL ... SBH 1245TL

Forward Current: 12 A

Reverse Voltage: 20 to 45 V

Preliminary Data

Features

- Max. solder temperature: 260°C
- Plastic material has UL classification 94V-0

Mechanical Data

- Plastic case: 5,4 x 7,5 [mm]
- Weight approx.: 1,6 g
- Terminals: plated terminals solderable per MIL-STD-750
- Mounting position: any
- Standard packaging: 1250 pieces per ammo or per reel

- 1) Valid, if leads are kept at ambient temperature at a distance 0mm from case
- 2) $I_F = 5 A$, $V_F < 600 mV$ @ $I_F = 12 A$, $T_j = 25 ^\circ C$
- 3) $T_A = 25 ^\circ C$
- 4) Thermal resistance from junction to lead/terminal at a distance 0 mm from case
- 5) Max. junction temperature $T_j \leq 200 ^\circ C$ in reverse mode $V_R = 80\% V_{RRM}$ and in bypass mode / DC forward mode

Absolute Maximum Ratings		$T_A = 25 ^\circ C$, unless otherwise specified	
Symbol	Conditions	Values	Units
I_{FAV}	Max. averaged fwd. current, R-load, $T_A = 75 ^\circ C$ ¹⁾	12	A
I_{FRM}	Repetitive peak forward current $f > 15 Hz$ ¹⁾	55	A
I_{FSM}	Peak forward surge current 50 Hz half sinus-wave ³⁾	300	A
i^2t	Rating for fusing, $t < 10 ms$ ³⁾	450	A ² s
R_{thA}	Max. thermal resistance junction to ambient ¹⁾		K/W
R_{thL}	Max. thermal resistance junction to terminals ⁴⁾	2	K/W
T_j	Operating junction temperature	- 50 ... + 200	°C
T_s	Storage temperature	- 50 ... + 200	°C

Characteristics		$T_A = 25 ^\circ C$, unless otherwise specified	
Symbol	Conditions	Values	Units
I_R	Maximum leakage current, $T_j = 25 ^\circ C$; $V_R = V_{RRM}$	<50	µA
	$T_j = 100 ^\circ C$; $V_R = V_{RRM}$	<2,5	mA
C_J	Typical junction capacitance (at MHz and applied reverse voltage of V)	-	pF
Q_{rr}	Reverse recovery charge ($U_R = V$; $I_F = A$; $dI_F/dt = A/ms$)	-	µC
E_{RSM}	Non repetitive peak reverse avalanche energy ($I_R = mA$; $T_j = ^\circ C$; inductive load switched off)	-	mJ

