

ICs for Communications

Digital Answering Machine with Full Duplex Speakerphone
SAM EC

PSB 4860 Version 2.1

Data Sheet 10.97

PSB 4860		
Revision History:		Current Version: 10.97
Previous Version:		Preliminary Data Sheet 09.97
Page (in previous Version)	Page (in new Version)	Subjects (major changes since last revision)
		Index added

Edition 10.97

This edition was realized using the software system FrameMaker®.

Published by Siemens AG,

HL TS

© Siemens AG 1997.

All Rights Reserved.

Attention please!

As far as patents or other rights of third parties are concerned, liability is only assumed for components, not for applications, processes and circuits implemented within components or assemblies.

The information describes the type of component and shall not be considered as assured characteristics.

Terms of delivery and rights to change design reserved.

For questions on technology, delivery and prices please contact the Semiconductor Group Offices in Germany or the Siemens Companies and Representatives worldwide (see address list).

Due to technical requirements components may contain dangerous substances. For information on the types in question please contact your nearest Siemens Office, Semiconductor Group.

Siemens AG is an approved CECC manufacturer.

Packing

Please use the recycling operators known to you. We can also help you – get in touch with your nearest sales office. By agreement we will take packing material back, if it is sorted. You must bear the costs of transport.

For packing material that is returned to us unsorted or which we are not obliged to accept, we shall have to invoice you for any costs incurred.

Components used in life-support devices or systems must be expressly authorized for such purpose!

Critical components¹ of the Semiconductor Group of Siemens AG, may only be used in life-support devices or systems² with the express written approval of the Semiconductor Group of Siemens AG.

- 1 A critical component is a component used in a life-support device or system whose failure can reasonably be expected to cause the failure of that life-support device or system, or to affect its safety or effectiveness of that device or system.
- 2 Life support devices or systems are intended (a) to be implanted in the human body, or (b) to support and/or maintain and sustain human life. If they fail, it is reasonable to assume that the health of the user may be endangered.

Table of Contents		Page
1	Overview	11
1.1	Features	12
1.2	Pin Configuration	13
1.3	Pin Definitions and Functions	14
1.4	Logic Symbol	18
1.5	Functional Block Diagram	19
1.6	System Integration	19
1.6.1	Analog Featurephone with Digital Answering Machine	19
1.6.2	Featurephone with Digital Answering Machine for ISDN Terminal	21
1.6.3	DECT Basestation with Integrated Digital Answering Machine	22
2	Functional Description	23
2.1	Functional Units	27
2.1.1	Full Duplex Speakerphone	27
2.1.2	Echo Cancellation	28
2.1.3	Echo Suppression	30
2.1.4	Line Echo Canceller	42
2.1.5	DTMF Detector	44
2.1.6	CNG Detector	45
2.1.7	Alert Tone Detector	46
2.1.8	CPT Detector	47
2.1.9	Caller ID Decoder	49
2.1.10	DTMF Generator	51
2.1.11	Speech Coder	52
2.1.12	Speech Decoder	54
2.1.13	Analog Front End Interface	55
2.1.14	Digital Interface	56
2.1.15	Universal Attenuator	58
2.1.16	Automatic Gain Control Unit	59
2.1.17	Equalizer	61
2.2	Memory Management	63
2.2.1	File Definition and Access	64
2.2.2	User Data Word	66
2.2.3	High Level Memory Management Commands	67
2.2.4	Low Level Memory Management Commands	75
2.2.5	Execution Time	77
2.2.6	Special Notes on File Commands	78
2.3	Miscellaneous	79
2.3.1	Real Time Clock	79
2.3.2	SPS Control Register	79
2.3.3	Reset and Power Down Mode	79
2.3.4	Interrupt	80
2.3.5	Abort	81

Table of Contents		Page
2.3.6	Revision Register82
2.3.7	Hardware Configuration82
2.3.8	Frame Synchronization82
2.3.9	Clock Tracking83
2.3.10	Dependencies of Modules83
2.4	Interfaces86
2.4.1	IOM [®] -2 Interface86
2.4.2	SSDI Interface90
2.4.3	Analog Front End Interface92
2.4.4	Serial Control Interface94
2.4.5	Memory Interface98
2.4.6	Auxiliary Parallel Port107
3	Detailed Register Description109
3.1	Status Register109
3.2	Hardware Configuration Registers111
3.3	Read/Write Registers115
3.3.1	Register Table115
3.3.2	Register Naming Conventions117
4	Electrical Characteristics225
4.1	Absolute Maximum Ratings225
4.2	DC Characteristics225
4.3	AC Characteristics227
5	Package Outlines247

IOM[®], IOM[®]-1, IOM[®]-2, SICOFI[®], SICOFI[®]-2, SICOFI[®]-4, SICOFI[®]-4 μ C, SLICOFI[®], ARCOFI[®], ARCOFI[®]-BA, ARCOFI[®]-SP, EPIC[®]-1, EPIC[®]-S, ELIC[®], IPAT[®]-2, ITAC[®], ISAC[®]-S, ISAC[®]-S TE, ISAC[®]-P, ISAC[®]-P TE, IDEC[®], SICAT[®], OCTAT[®]-P, QUAT[®]-S are registered trademarks of Siemens AG.

DigiTape[™], MUSAC[™]-A, FALC[™]54, IWE[™], SARE[™], UTPT[™], ASM[™], ASP[™] are trademarks of Siemens AG.

List of Figures	Page
General	
Figure 1: Pin Configuration of PSB 4860	13
Figure 2: Logic Symbol of PSB 4860	18
Figure 3: Block Diagram of PSB 4860	19
Figure 4: Analog Full Duplex Speakerphone with Digital Answering Machine	20
Figure 5: Featurephone with Answering Machine for ISDN Terminal	21
Figure 6: DECT Basestation	22
Functional Units	
Figure 7: Functional Units - Overview	23
Figure 8: Functional Units - Recording a Phone Conversation	25
Figure 9: Functional Units - Simultaneous Internal and External Call	26
Figure 10: Speakerphone - Signal Connections	27
Figure 11: Speakerphone - Block Diagram	27
Figure 12: Echo Cancellation Unit - Block Diagram	28
Figure 13: Echo Cancellation Unit - Typical Room Impulse Response	29
Figure 14: Echo Suppression Unit - States of Operation	30
Figure 15: Echo Suppression Unit - Signal Flow Graph	31
Figure 16: Speech Detector - Signal Flow Graph	32
Figure 17: Speech Comparator - Block Diagram	35
Figure 18: Speech Comparator - Interdependence of Parameters	36
Figure 19: Echo Suppression Unit - Automatic Gain Control	39
Figure 20: Line Echo Cancellation Unit - Block Diagram	42
Figure 21: DTMF Detector - Block Diagram	44
Figure 22: CNG Detector - Block Diagram	45
Figure 23: Alert Tone Detector - Block Diagram	46
Figure 24: CPT Detector - Block Diagram	47
Figure 25: CPT Detector - Cooked Mode	47
Figure 26: Caller ID Decoder - Block Diagram	49
Figure 27: DTMF Generator - Block Diagram	51
Figure 28: Speech Coder - Block Diagram	52
Figure 29: Speech Decoder - Block Diagram	54
Figure 30: Analog Front End Interface - Block Diagram	55
Figure 31: Digital Interface - Block Diagram	56
Figure 32: Universal Attenuator - Block Diagram	58
Figure 33: Automatic Gain Control Unit - Block Diagram	59
Figure 34: Equalizer - Block Diagram	61
Memory Management	
Figure 35: Memory Management - Data Flow	63
Figure 36: Memory Management - Directory Structure	63
Figure 37: Audio File Organization - Example	64
Figure 38: Binary File Organization - Example	64

List of Figures	Page
Figure 39: Phrase File Organization - Example	65
 Miscellaneous	
Figure 40: Operation Modes - State Chart.	80
 Interfaces	
Figure 41: IOM [®] -2 Interface - Frame Structure	86
Figure 42: IOM [®] -2 Interface - Frame Start.	87
Figure 43: IOM [®] -2 Interface - Single Clock Mode	87
Figure 44: IOM [®] -2 Interface - Double Clock Mode	88
Figure 45: SSDI Interface - Transmitter Timing	90
Figure 46: SSDI Interface - Active Pulse Selection	91
Figure 47: SSDI Interface - Receiver Timing	91
Figure 48: Analog Front End Interface - Frame Structure	92
Figure 49: Analog Front End Interface - Frame Start	93
Figure 50: Analog Front End Interface - Data Transfer	93
Figure 51: Status Register Read Access.	94
Figure 52: Data Read Access	95
Figure 53: Register Write Access	95
Figure 54: Configuration Register Read Access	96
Figure 55: Configuration Register Write Access or Register Read Command	96
Figure 56: ARAM/DRAM Interface - Connection Diagram.	99
Figure 57: ARAM/DRAM Interface - Read Cycle Timing	100
Figure 58: ARAM/DRAM Interface - Write Cycle Timing	101
Figure 59: ARAM/DRAM Interface - Refresh Cycle Timing.	101
Figure 60: EPROM Interface - Connection Diagram	102
Figure 61: EPROM Interface - Read Cycle Timing	102
Figure 62: Flash Memory Interface - Connection Diagram	103
Figure 63: Flash Memory Interface - Multiple Devices	104
Figure 64: Flash Memory Interface - Command Write.	105
Figure 65: Flash Memory Interface - Address Write	105
Figure 66: Flash Memory Interface - Data Write	106
Figure 67: Flash Memory Interface - Data Read	106
Figure 68: Auxiliary Parallel Port - Multiplex Mode	108
 Electrical Characteristics	
Figure 69: Input/Output Waveforms for AC-Tests	227
 Timing Diagrams	
Figure 70: Oscillator Circuits	231
Figure 71: SSDI/IOM [®] -2 Interface - Bit Synchronization Timing	232
Figure 72: SSDI/IOM [®] -2 Interface - Frame Synchronization Timing	232
Figure 73: SSDI Interface - Strobe Timing.	234

List of Figures	Page
Figure 74: Serial Control Interface	235
Figure 75: Analog Front End Interface	236
Figure 76: Memory Interface - DRAM Read Access	237
Figure 77: Memory Interface - DRAM Write Access	238
Figure 78: Memory Interface - DRAM Refresh Cycle	239
Figure 79: Memory Interface - EPROM Read	240
Figure 80: Memory Interface - Samsung Command Write	241
Figure 81: Memory Interface - Samsung Address Write	242
Figure 82: Memory Interface - Samsung Data Write	243
Figure 83: Memory Interface - Samsung Data Read	244
Figure 84: Auxiliary Parallel Port - Multiplex Mode	245
Figure 85: Reset Timing	246

List of Tables	Page
General	
Table 1: Pin Definitions and Functions	14
Functional Units	
Table 2: Signal Summary	24
Table 3: Echo Cancellation Unit Registers	28
Table 4: Speech Detector Parameters	34
Table 5: Speech Comparator Parameters	37
Table 6: Attenuation Control Unit Parameters	38
Table 7: SPS Output Encoding	38
Table 8: Automatic Gain Control Parameters	40
Table 9: Fixed Gain Parameters	40
Table 10: Speakerphone Control Registers	40
Table 11: Line Echo Cancellation Unit Registers	43
Table 12: DTMF Detector Control Register	44
Table 13: DTMF Detector Results	44
Table 14: DTMF Detector Parameters	44
Table 15: CNG Detector Registers	45
Table 16: CNG Detector Result	45
Table 17: Alert Tone Detector Registers	46
Table 18: Alert Tone Detector Results	46
Table 19: CPT Detector Result	48
Table 20: CPT Detector Registers	48
Table 21: Caller ID Decoder Modes	49
Table 22: Caller ID Decoder Status	49
Table 23: Caller ID Decoder Registers	49
Table 24: DTMF Generator Registers	51
Table 25: Speech Coder Status	52
Table 26: Speech Coder Registers	53
Table 27: Speech Decoder Registers	54
Table 28: Analog Front End Interface Registers	55
Table 29: Digital Interface Registers	56
Table 30: Universal Attenuator Registers	58
Table 31: Automatic Gain Control Registers	59
Table 32: Equalizer Registers	61
Memory Management - General	
Table 33: Memory Management Registers	65
Table 34: Memory Management Status	65
Table 35: Memory Management Parameters	66
Memory Management - Commands	
Table 36: Initialize Memory Parameters	67

Table 37: Initialize Memory Results	67
Table 38: Activate Memory Parameters	68
Table 39: Activate Memory Results	68
Table 40: Activate Memory Result Interpretation	68
Table 41: Open File Parameters	69
Table 42: Open Next Free File Parameters	69
Table 43: Open Next Free File Results	70
Table 44: Seek Parameters	70
Table 45: Cut File Parameters	71
Table 46: Compress File Parameters	71
Table 47: Memory Status Parameters	72
Table 48: Memory Status Results	72
Table 49: Garbage Collection Parameters	72
Table 50: Access File Descriptor Parameters	73
Table 51: Access File Descriptor Results	73
Table 52: Read Data Parameters	73
Table 53: Read Data Results	73
Table 54: Write Data Parameters	74
Table 55: Set Address Parameters	75
Table 56: DMA Read Parameters	75
Table 57: DMA Read Results	75
Table 58: DMA Write Parameters	76
Table 59: Block Erase Parameters	76
Table 60: Execution Times	77
Miscellaneous	
Table 61: Real Time Clock Registers	79
Table 62: SPS Registers	79
Table 63: Power Down Bit	80
Table 64: Interrupt Source Summary	81
Table 65: Hardware Configuration Checklist	82
Table 66: Frame Synchronization Selection	82
Table 67: Dependencies of Modules	83
Table 68: File Command Classes	83
Table 69: Module Weights	84
Interfaces	
Table 70: SSDI vs. IOM [®] -2 Interface	86
Table 71: IOM [®] -2 Interface Registers	88
Table 72: SSDI Interface Register	91
Table 73: Control of ALS Amplifier	92
Table 74: Analog Front End Interface Register	92
Table 75: Analog Front End Interface Clock Cycles	93

Table 76: Command Words for Register Access	97
Table 77: Address Field W for Configuration Register Write	97
Table 78: Address Field R for Configuration Register Read	97
Table 79: Supported Memory Configurations.	98
Table 80: Address Line Usage (ARAM/DRAM Mode)	100
Table 81: Refresh Frequency Selection	101
Table 82: Address Line Usage (Samsung Mode).	103
Table 83: Flash Memory Command Summary.	104
Table 84: Static Mode Registers	107
Table 85: Multiplex Mode Registers	107
Table 86: Signal Encoding	117
 Electrical Characteristics	
Table 87: Status Register Update Timing.	230

1 Overview

Combined with an analog front end the PSB 4860 provides a solution for embedded or stand alone answering machine applications. Together with a standard microcontroller for analog telephones these two chips form the core of a featurephone with full duplex speakerphone and answering machine capabilities.

The chip features recording by DigiTape™, a family of high performance algorithms. Messages recorded with DigiTape™ can be played back with variable speed without pitch alteration. Messages recorded with a higher bitrate can be converted into messages with a lower bitrate arbitrarily. Current members of DigiTape (TM) span the range from 3.3 kbit/s to 10.3 kbit/s.

Furthermore the PSB 4860, V2.1 has a full duplex speakerphone, a caller ID decoder, DTMF recognition and generation and call progress tone detection. The frequency response of cheap microphones or loudspeakers can be corrected by a programmable equalizer.

Messages and user data can be stored in ARAM/DRAM or flash memory which can be directly connected to the PSB 4860. The PSB 4860 also supports a voice prompt EPROM for fixed announcements.

The PSB 4860 provides an IOM®-2 compatible interface with two channels for speech data.

Alternatively to the IOM®-2 compatible interface the PSB 4860 supports a simple serial data interface (SSDI) with separate strobe signals for each direction (linear PCM data, one channel).

A separate interface is used for a glueless connection to the PSB 4851.

The chip is programmed by a simple four wire serial control interface and can inform the microcontroller of new events by an interrupt signal. For data retention the PSB 4860 supports a power down mode where only the real time clock and the memory refresh (in case of ARAM/DRAM) are operational.

The PSB 4860 supports interface pins to +5 V levels.

Digital Answering Machine with Full Duplex Speakerphone SAM EC

PSB 4860

Version 2.1

CMOS

1.1 Features

Digital Functions

- High performance recording by DigiTape™
- Selectable compression rate (3.3 kbit/s, 10.3 kbit/s)
- Variable playback speed
- Support for ARAM or Flash Memory
- Optional voice prompt EPROM
- Full duplex speakerphone
- DTMF generation and detection
- Call progress tone detection
- Caller ID recognition
- Direct memory access
- Real time clock
- Equalizer
- Automatic gain control
- Automatic timestamp
- Auxiliary parallel port
- Ultra low power refresh mode

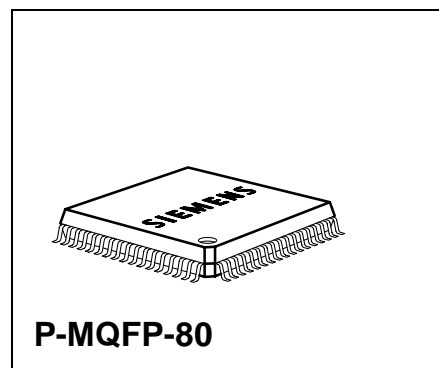

General Features

- SSDI/IOM®-2 compatible interface
- Serial control interface for programming

Type	Package
PSB 4860	P-MQFP-80

1.2 Pin Configuration
(top view)

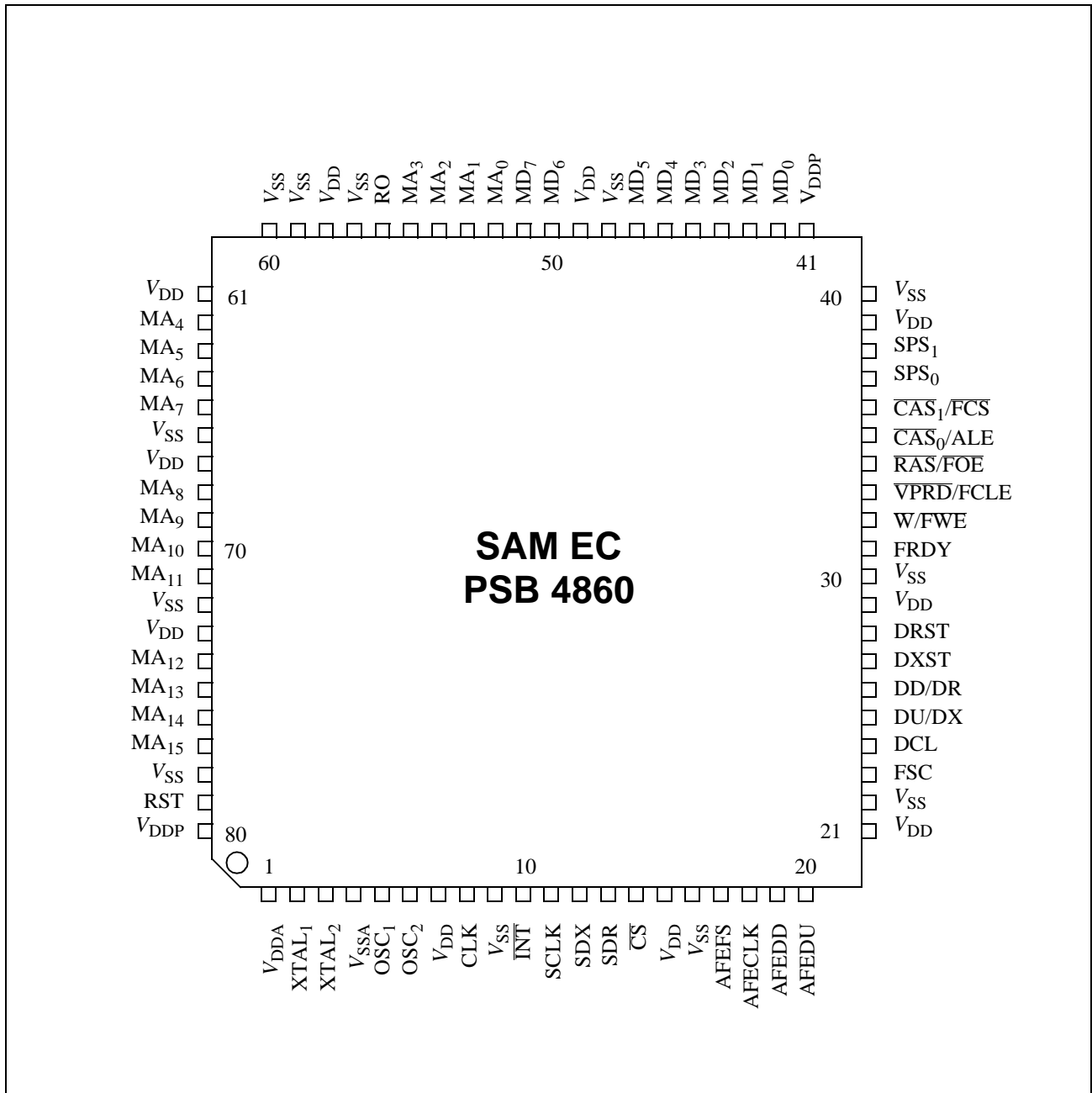

Figure 1 Pin Configuration of PSB 4860

1.3 Pin Definitions and Functions

Table 1 Pin Definitions and Functions

Pin No. P-MQFP-80	Symbol	Dir.	Reset	Function
41, 80	V_{DDP}	-	-	Power supply (5V \pm10 %) Power supply for the interface.
7, 15, 21, 29, 39, 49, 58, 61, 67, 73	V_{DD}	-	-	Power supply (3.0 V - 3.6 V) Power supply for logic.
1	V_{DDA}	-	-	Power supply (3.0 V - 3.6 V) Power supply for clock generator.
4	V_{SSA}	-	-	Power supply (0 V) Ground for clock generator.
9, 16, 22, 30, 40, 48, 57, 59, 60, 78, 66, 72	V_{SS}	-	-	Power supply (0 V) Ground for logic and interface.
17	AFEFS	O	L	Analog Frontend Frame Sync: 8 kHz frame synchronization signal for the analog front end.
18	AFECLK	O	L	Analog Frontend Clock: Clock signal for the analog front end.
19	AFEDD	O	L	Analog Frontend Data Downstream: Data output to the analog frontend.
20	AFEDU	I	-	Analog Frontend Data Upstream: Data input from the analog frontend.
79	RST	I	-	Reset: Active high reset signal.
23	FSC	I	-	Data Frame Synchronization: 8 kHz frame synchronization signal (IOM [®] -2 and SSDI mode).
24	DCL	I	-	Data Clock: Data Clock of the serial data interface.

Table 1 Pin Definitions and Functions

26	DD/DR	I/OD I	-	IOM[®]-2 Compatible Mode: Receive data from IOM [®] -2 controlling device. SSDI Mode: Receive data of the strobed serial data interface.
25	DU/DX	I/OD O/ OD	-	IOM[®]-2 Compatible Mode: Transmit data to IOM [®] -2 controlling device. SSDI Mode: Transmit data of the strobed serial data interface.
27	DXST	O	L	DX Strobe: Strobe for DX in SSDI interface mode.
28	DRST	I	-	DR Strobe: Strobe for DR in SSDI interface mode.
14	\overline{CS}	I	-	Chip Select: Select signal of the serial control interface (SCI).
11	SCLK	I	-	Serial Clock: Clock signal of the serial control interface (SCI).
13	SDR	I	-	Serial Data Receive: Data input of the serial control interface (SCI).
12	SDX	O/ OD	H	Serial Data Transmit: Data Output of the serial control interface (SCI).
10	INT	O/ OD	H	Interrupt New status available.

Table 1 Pin Definitions and Functions

52	MA ₀	I/O	L ¹⁾	Memory Address 0-15: Multiplexed address outputs for ARAM, DRAM access. Non-multiplexed address outputs for voice prompt EPROM. Auxiliary Parallel Port: General purpose I/O.
53	MA ₁	I/O	L	
54	MA ₂	I/O	L	
55	MA ₃	I/O	L	
62	MA ₄	I/O	L	
63	MA ₅	I/O	L	
64	MA ₆	I/O	L	
65	MA ₇	I/O	L	
68	MA ₈	I/O	L	
69	MA ₉	I/O	L	
70	MA ₁₀	I/O	L	
71	MA ₁₁	I/O	L	
74	MA ₁₂	I/O	L	
75	MA ₁₃	I/O	L	
76	MA ₁₄	I/O	L	
77	MA ₁₅	I/O	L	
42	MD ₀	I/O	-	Memory Data 0-7: Memory (ARAM, DRAM, Flash Memory, EPROM) data bus.
43	MD ₁	I/O	-	
44	MD ₂	I/O	-	
45	MD ₃	I/O	-	
46	MD ₄	I/O	-	
47	MD ₅	I/O	-	
50	MD ₆	I/O	-	
51	MD ₇	I/O	-	
35	$\overline{\text{CAS}}_0$ / ALE	O	H ²⁾	ARAM, DRAM: Column address strobe for memory bank 0 or 1. Flash Memory: Address Latch Enable for address lines A ₁₆ -A ₂₃ . Chip select signal for Flash Memory
36	$\overline{\text{CAS}}_1$ / FCS	O		
34	$\overline{\text{RAS}}$ / FOE	O	H ²⁾	ARAM, DRAM: Row address strobe for both memory banks. Flash Memory: Output enable signal for Flash Memory.
33	$\overline{\text{VPRD}}$ / FCLE	O	H ²⁾	ARAM, DRAM: Read signal for voice prompt EPROM. Flash Memory: Command latch enable for Flash Memory.

Table 1 Pin Definitions and Functions

32	$\overline{W}/\overline{FWE}$	O	H ²⁾	ARAM, DRAM: Write signal for all memory banks. Flash Memory: Write signal for Flash Memory.
31	FRDY	I	-	Flash Memory Ready Input for Ready/Busy signal of Flash Memory
5 6	OSC ₁ OSC ₂	I O	- Z	Auxiliary Oscillator: Oscillator loop for 32.768 kHz crystal.
8	CLK	I	-	Alternative AFCLK Source 13,824 MHz
2 3	XTAL ₁ XTAL ₂	I O	- Z	Oscillator: XTAL ₁ : External clock or input of oscillator loop. XTAL ₂ : output of oscillator loop for crystal.
37 38	SPS ₀ SPS ₁	O O	L L	Multipurpose Outputs: General purpose, speakerphone, address lines or status
56	RO	O	-	Reserved Output Must be left open.

¹⁾ These lines are driven low with 125 μ A until the mode (address lines or auxiliary port) is defined.

²⁾ These lines are driven high with 70 μ A during reset.

1.4 Logic Symbol

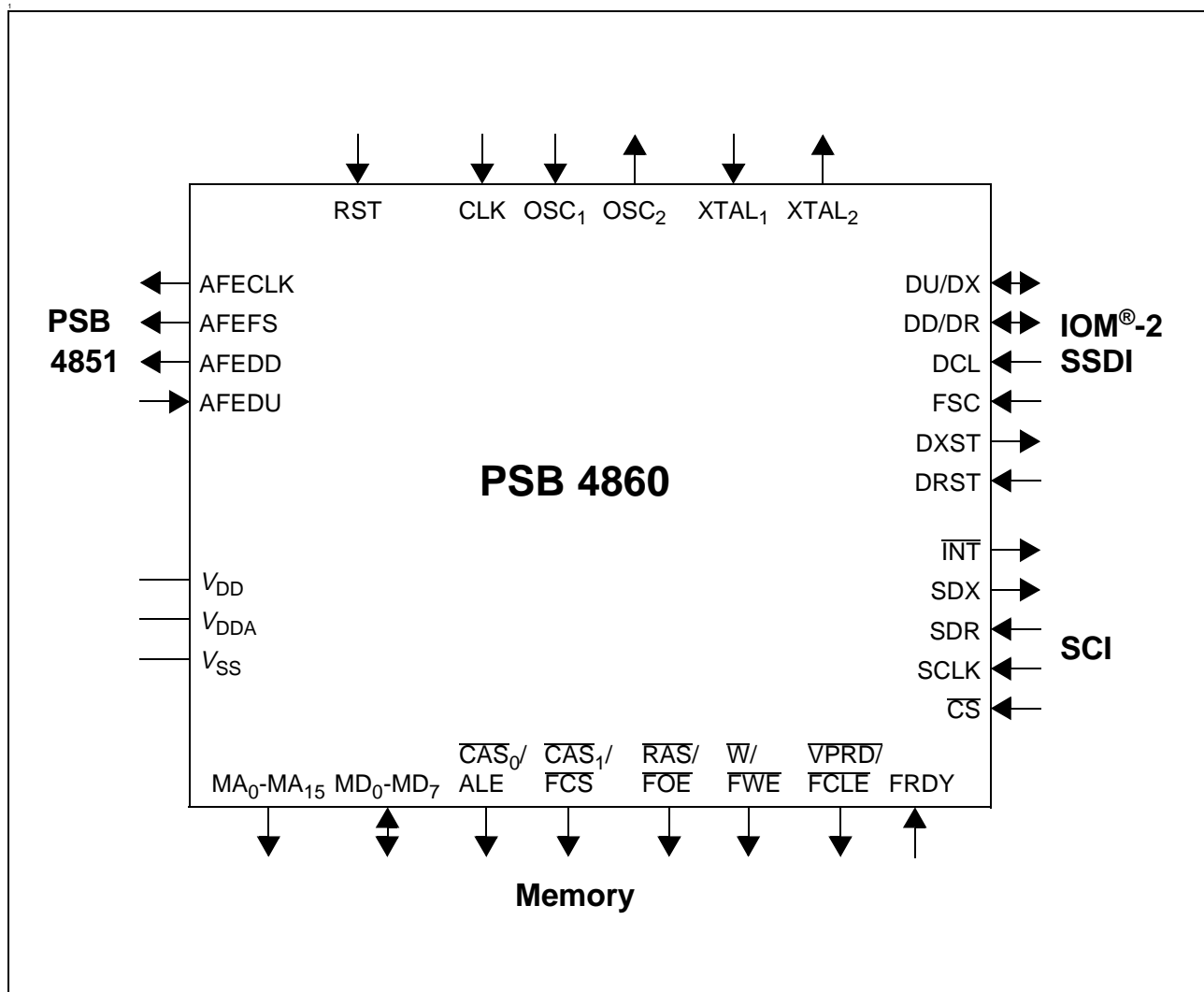

Figure 2 Logic Symbol of PSB 4860

1.5 Functional Block Diagram

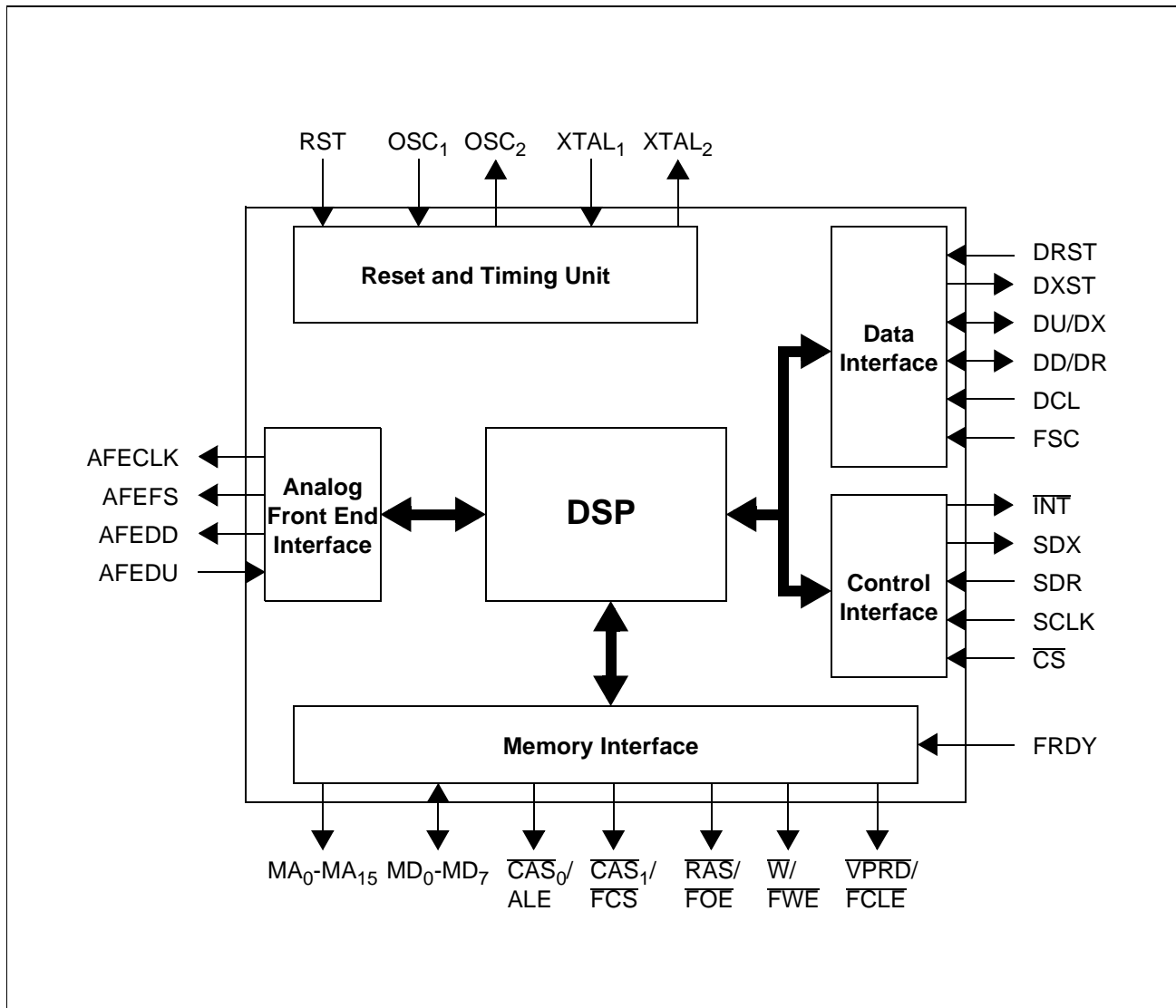

Figure 3 Block Diagram of PSB 4860

1.6 System Integration

The PSB 4860 combined with an analog front end (PSB 4851) can be used in a variety of applications. This combination offers outstanding features like full duplex speakerphone and emergency operation. Some applications are given in the following sections.

1.6.1 Analog Featurephone with Digital Answering Machine

Figure 4 shows an example of an analog telephone system. The telephone can operate during power failure by line powering. In this case only the handset and ringer circuit are active. All other parts of the chipset are shut down leaving enough power for the external microcontroller to perform basic tasks like keyboard monitoring.

Overview

For answering machine operation the voice data is stored in ARAM or Flash Memory devices. In addition, voice prompts can be played back from an optional voice prompt EPROM. If flash memory is used the functionality of the voice prompt EPROM can be realized by the flash memory devices. The microcontroller can use the memory attached to the PSB 4860/PSB 4851 to store and retrieve binary data.

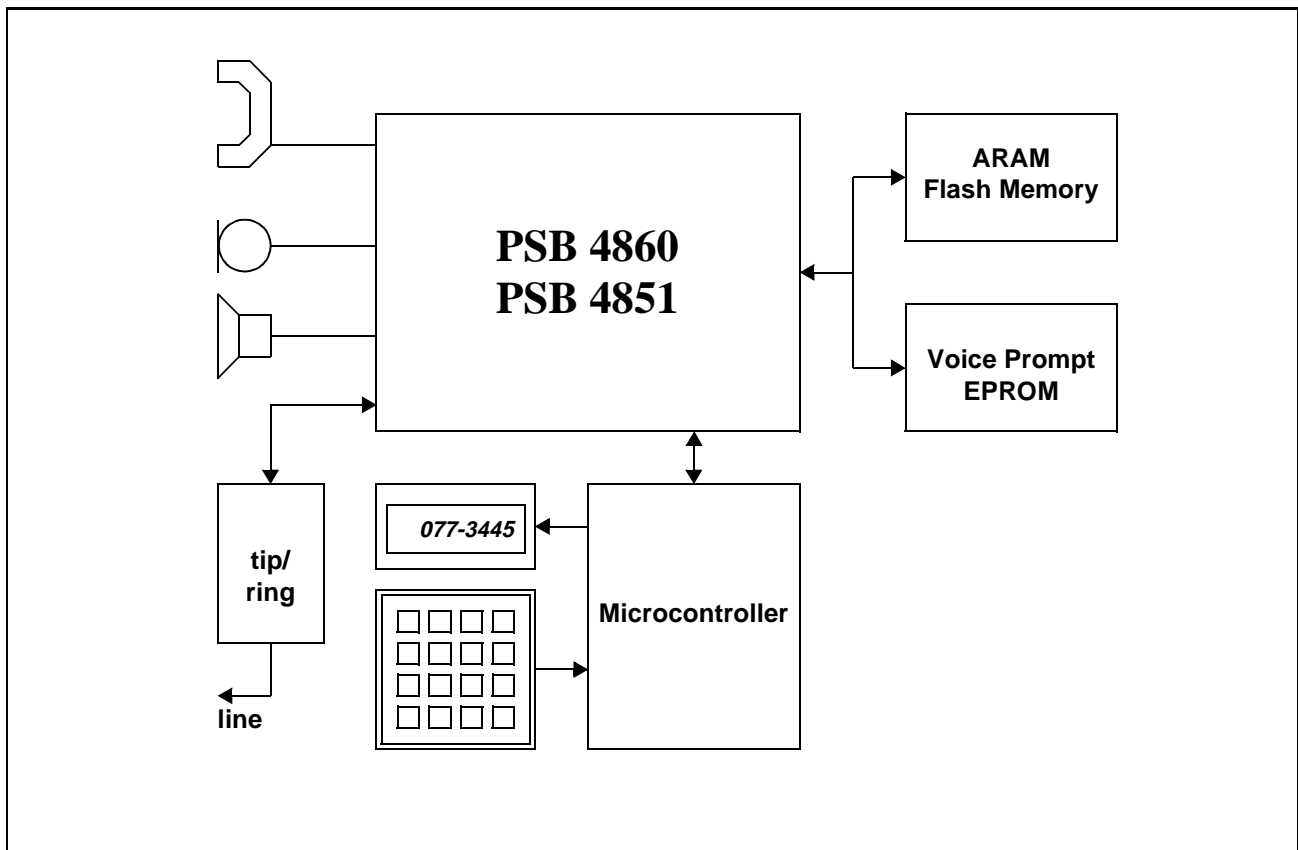

Figure 4 Analog Full Duplex Speakerphone with Digital Answering Machine

1.6.2 Featurephone with Digital Answering Machine for ISDN Terminal

Figure 5 shows an ISDN featurephone that takes full advantage of two simultaneous connections. In this application one channel of the PSB 4851 interfaces to the handset and speakerphone while the other provides an interface for an external analog device (e.g. FAX machine).

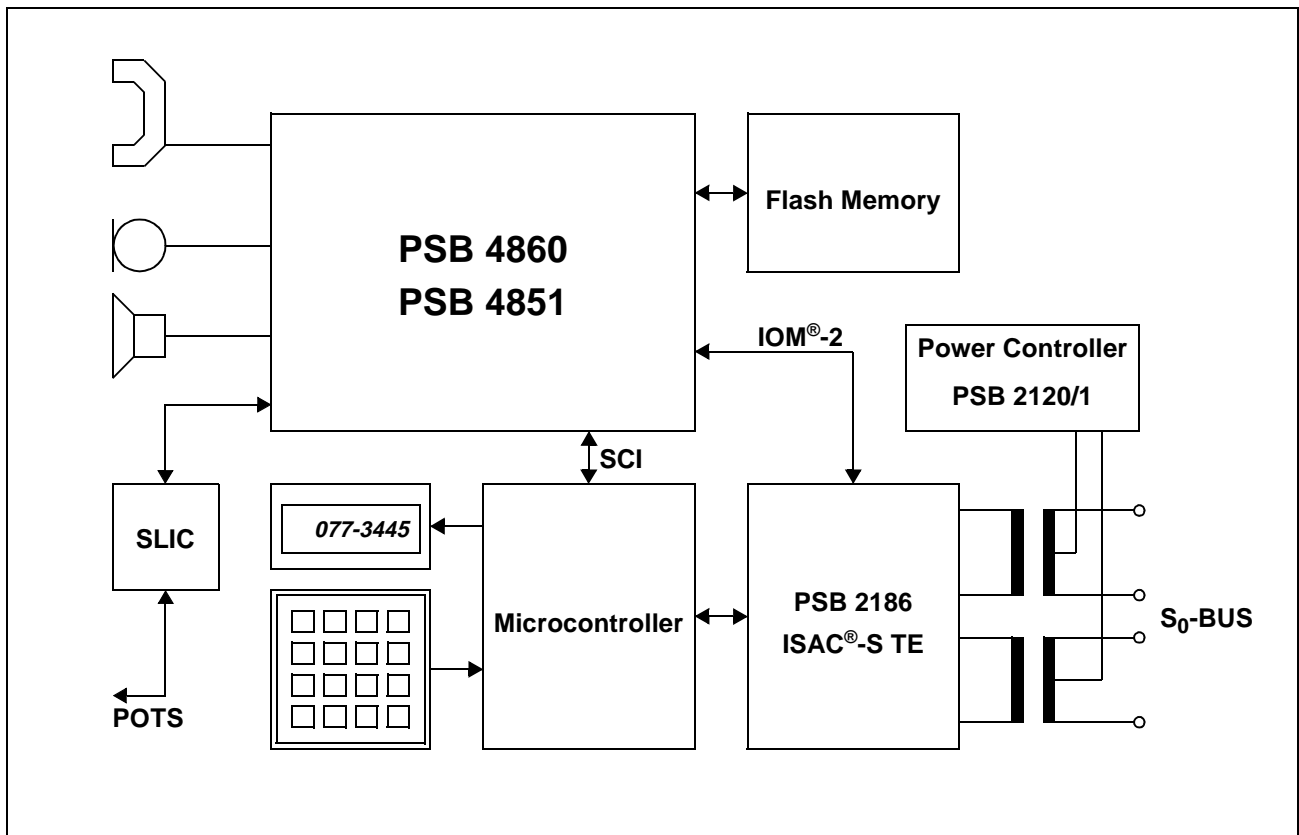

Figure 5 Featurephone with Answering Machine for ISDN Terminal

In addition, the two channels of the PSB 4851 can be used for holding two connections simultaneously. One connection can be switched to the handset and the other to the speakerphone box. Local three party conferences are also possible.

1.6.3 DECT Basestation with Integrated Digital Answering Machine

Figure 6 shows a DECT basestation based on the PSB 4860/PSB 4851 chipset. In this application it is possible to service both an external call and an internal call at the same time. For programming the serial control interface (SCI) is used while voice data is transferred via the strobed serial data interface (SSDI/IOM[®]-2).

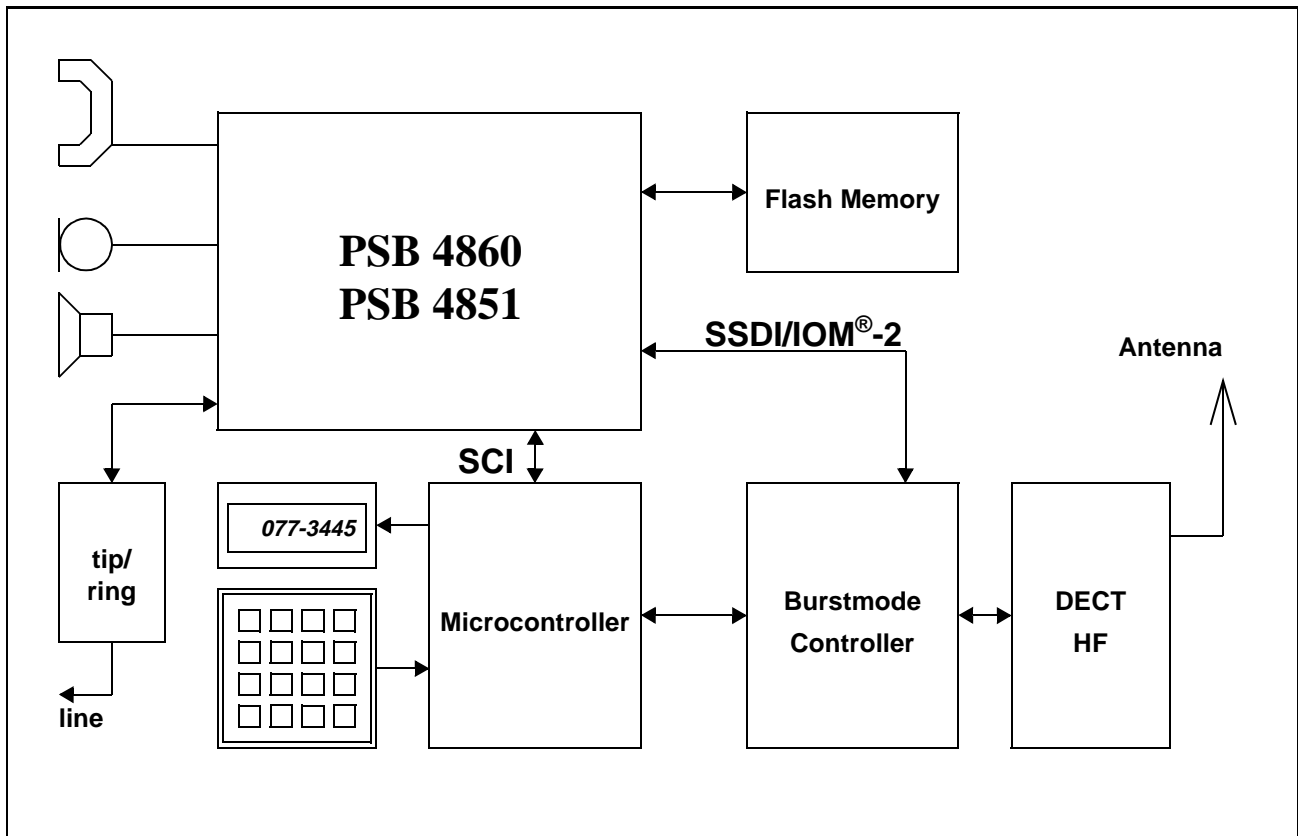

Figure 6 DECT Basestation

Functional Description

2 Functional Description

The PSB 4860 contains several functional units that can be combined with almost no restrictions to perform a given task. Figure 7 gives an overview of the important functional units.

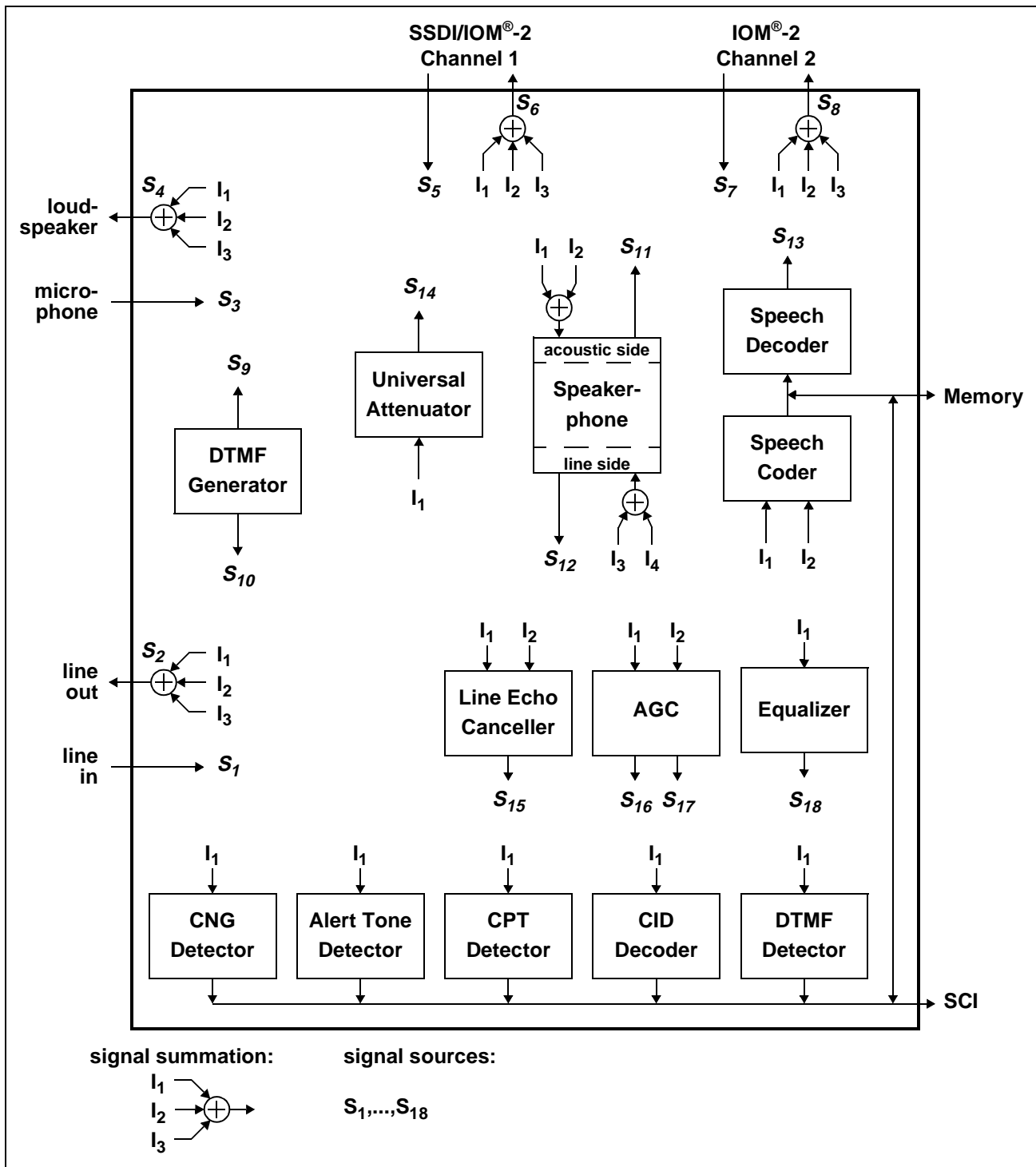

Figure 7 Functional Units - Overview

Functional Description

Each unit has one or more signal inputs (denoted by I). Most units have at least one signal output (denoted by S). Any input I can be connected to any signal output S. In addition to the signals shown in figure 7 there is also the signal S₀ (silence), which is useful at signal summation points. Table 2 lists the available signals within the PSB 4860 according to their reference points.

Table 2 Signal Summary

Signal	Description
S ₀	Silence
S ₁	Analog line input (channel 1 of PSB 4851 interface)
S ₂	Analog line output (channel 1 of PSB 4851 interface)
S ₃	Microphone input (channel 2 of PSB 4851 interface)
S ₄	Loudspeaker/Handset output (channel 2 of PSB 4851 interface)
S ₅	Serial interface input, channel 1
S ₆	Serial interface output, channel 1
S ₇	Serial interface input, channel 2
S ₈	Serial interface output, channel 2
S ₉	DTMF generator output
S ₁₀	DTMF generator auxiliary output
S ₁₁	Speakerphone output (acoustic side)
S ₁₂	Speakerphone output (line side)
S ₁₃	Speech decoder output
S ₁₄	Universal attenuator output
S ₁₅	Line echo canceller output
S ₁₆	Automatic gain control output (after gain stage)
S ₁₇	Automatic gain control output (before gain stage)
S ₁₈	Equalizer output

Functional Description

The following figures show the connections for two typical states during operation. Units that are not needed are not shown. Inputs that are not needed are connected to S_0 which provides silence (denoted by 0). In figure 8 a hands-free phone conversation is currently in progress. The speech coder is used to record the signals of both parties. The alert tone detector is used to detect an alerting tone of an off-hook caller id request while the CID decoder decodes the actual data transmitted in this case.

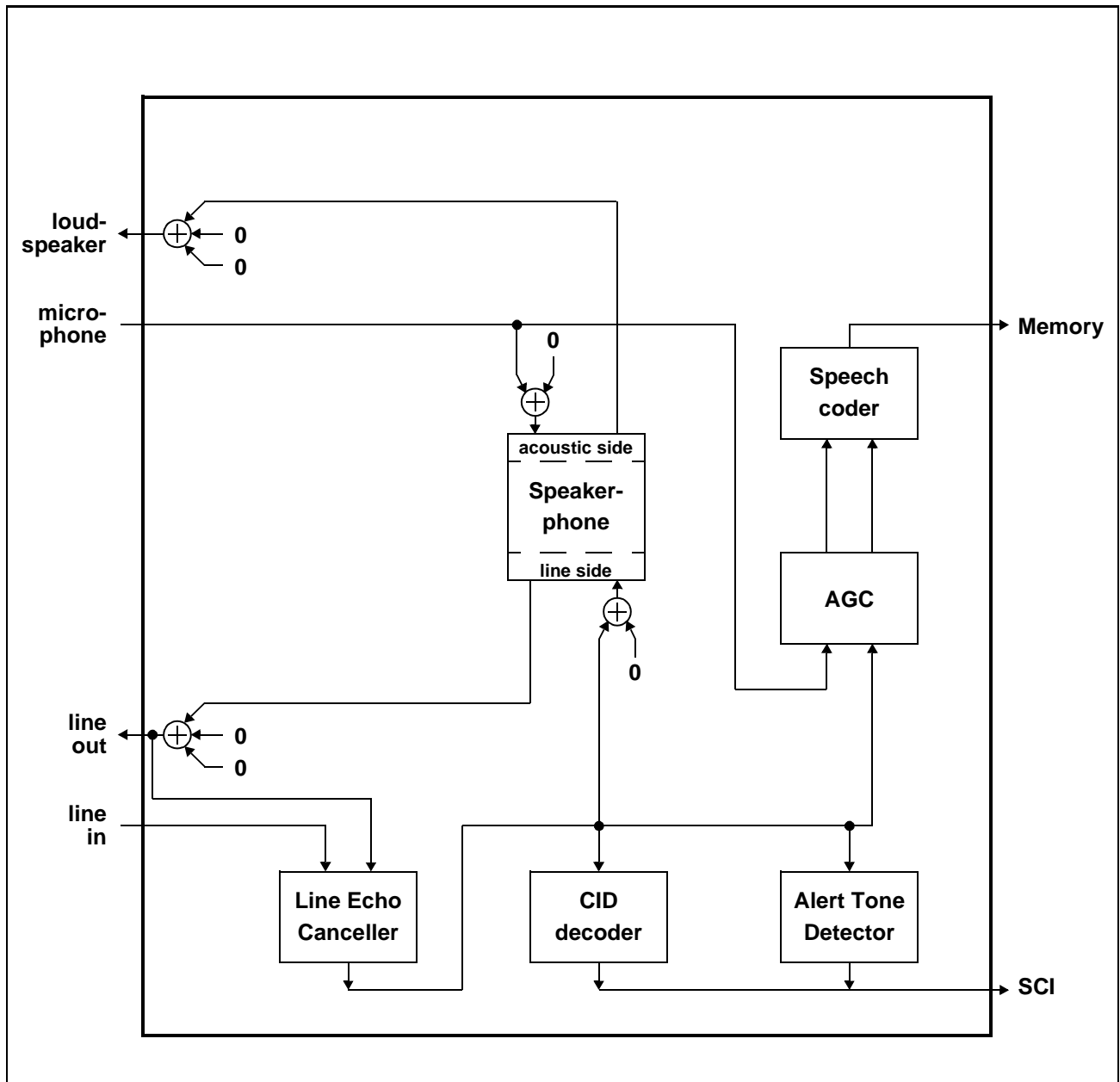

Figure 8 Functional Units - Recording a Phone Conversation

Functional Description

In figure 9 a phone conversation using the speakerphone is in progress. One party is using the base station of a DECT system while the other party is using a mobile handset. At the same time an external call is serviced by the answering machine. In the current state a message (recorded or outgoing) is being played back. In this case the DTMF detector is used to detect signals for remote access while the CPT detector is used to determine the end of the external call.

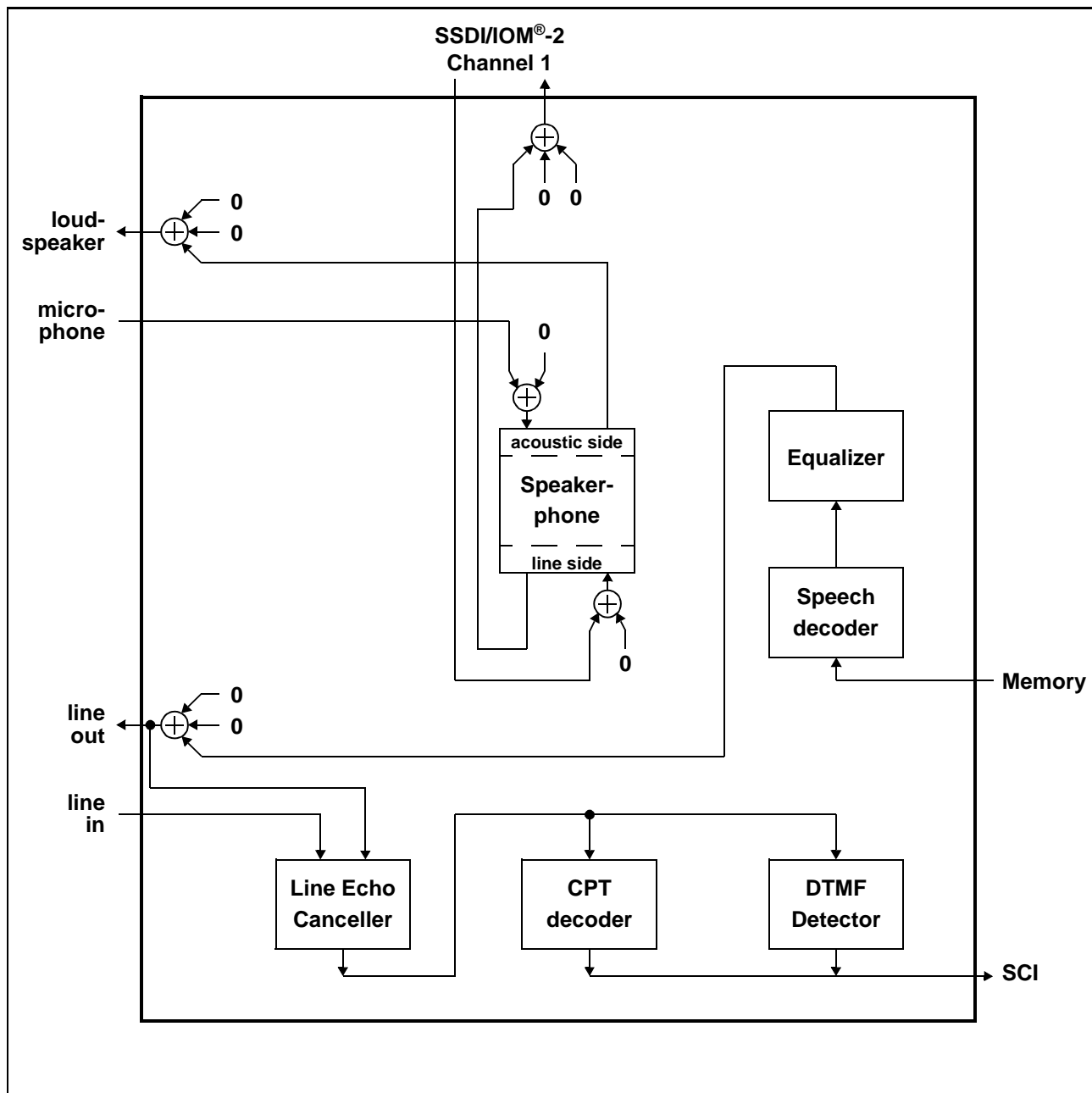

Figure 9 Functional Units - Simultaneous Internal and External Call

Functional Description

2.1 Functional Units

In this section the functional units of the PSB 4860 are described in detail. The functional units can be individually enabled or disabled.

2.1.1 Full Duplex Speakerphone

The speakerphone unit (figure 10) is attached to four signals (microphone, loudspeaker, line out and line in). The two input signals (microphone, line in) are preceded by a signal summation point.

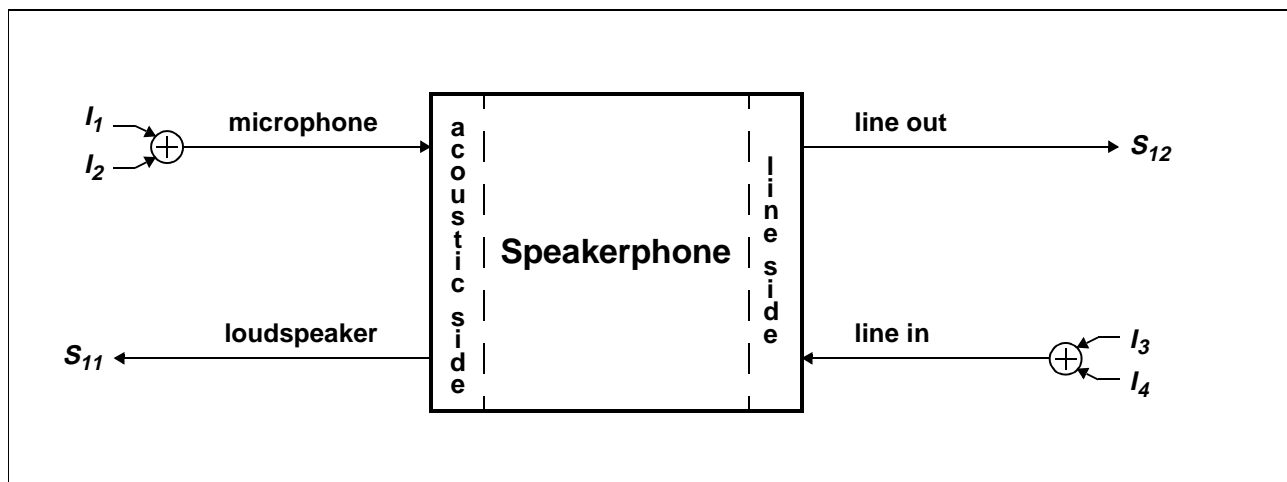

Figure 10 Speakerphone - Signal Connections

Internally, this unit can be divided into an echo cancellation unit and an echo suppression unit (figure 11). The echo cancellation unit provides the attenuation G_C while the echo suppression unit provides the attenuation G_S . The total attenuation ATT of the speakerphone is therefore $ATT=G_C+G_S$.

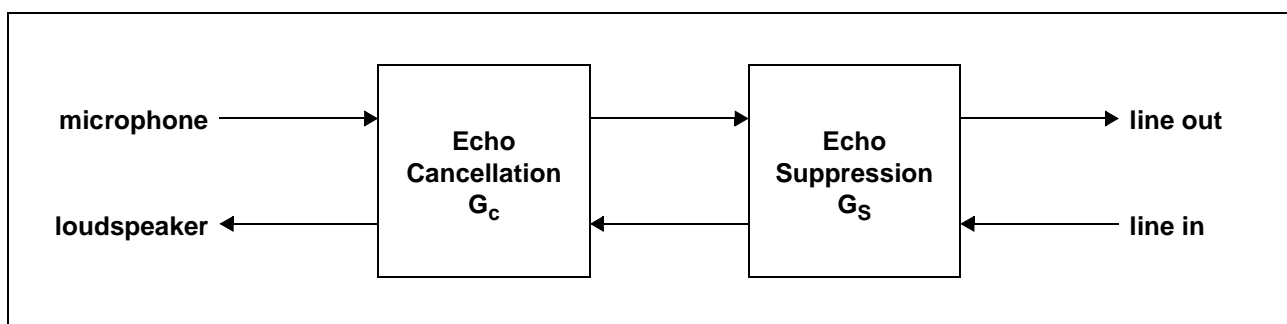

Figure 11 Speakerphone - Block Diagram

The echo suppression unit can be enabled without the echo cancellation unit. If the echo cancellation unit is disabled, the echo suppression unit still provides speakerphone functionality, albeit only half duplex. As the echo cancellation must be disabled during recording or playback of speech data, this option allows for speakerphone operation

Functional Description

even if recording or playback is going on. The echo suppression unit is also used to provide additional attenuation if the echo cancellation unit cannot provide all of the required attenuation itself.

2.1.2 Echo Cancellation

A simplified block diagram of the echo cancellation unit is shown in figure 12.

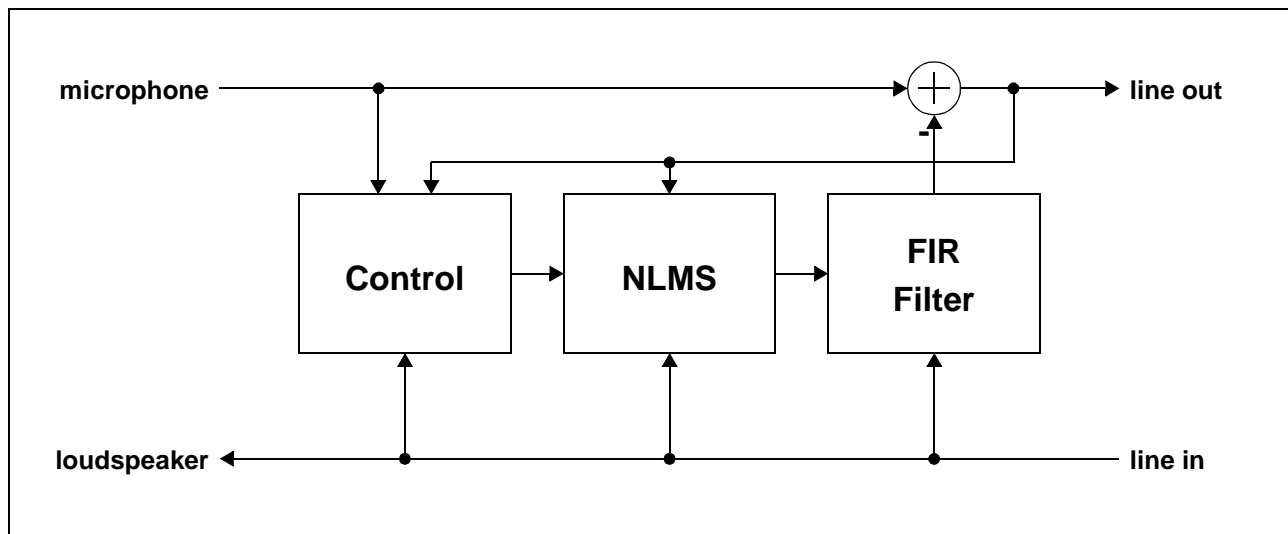

Figure 12 Echo Cancellation Unit - Block Diagram

The echo cancellation unit consists of an finite impulse response filter (FIR) that models the expected acoustic echo, an NLMS based adaption unit and a control unit. The expected echo is subtracted from the actual input signal from the microphone. If the model is exact and the echo does not exceed the length of the filter then the echo can be completely cancelled. However, even if this ideal state can be achieved for one given moment the acoustic echo usually changes over time. Therefore the NLMS unit continuously adapts the coefficients of the FIR filter. This adaption process is steered by the control unit. As an example, the adaption is inhibited as long as double talk is detected by the control unit. Furthermore the control unit informs the echo suppression unit about the achieved echo return loss.

Table 3 shows the registers associated with the echo cancellation unit.

Table 3 Echo Cancellation Unit Registers

Register	# of Bits	Name	Comment
SAELEN	9	LEN	Length of FIR filter
SAEATT	15	ATT	Attenuation reduction during double-talk
SAEGS	3	GS	Global scale (all blocks)

Functional Description

Table 3 Echo Cancellation Unit Registers

SAEPS1	3	AS	Partial scale (for blocks \geq SAEPS2:FB)
SAEPS2	3	FB	First block affected by partial scale

The length of the FIR filter can be varied from 127 to 511 taps (15.875ms to 63.875ms). The taps are grouped into blocks. Each block contains 64 taps.

The performance of the FIR filter can be enhanced by prescaling some or call of the coefficients of the FIR filter. A coefficient is prescaled by multiplying it by a constant. The advantage of prescaling is an enhanced precision and consequently an enhanced echo cancellation. The disadvantage is a reduced echo cancellation performance if the signal exceeds the maximal coefficient value. More precisely, if a coefficient at tap T_i is scaled by a factor C_i then the level of the echo (room impulse response) must not exceed Max/C_i (Max: Maximum PCM value). As an example figure shows a typical room impulse response.

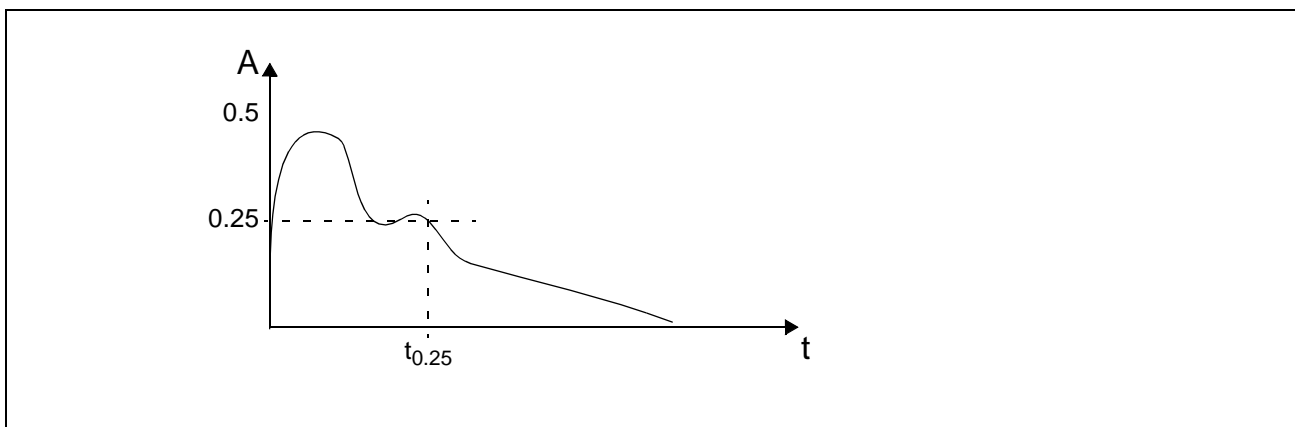

Figure 13 Echo Cancellation Unit - Typical Room Impulse Response

First of all, the echo never exceeds 0.5 of the maximum value. Furthermore the echo never exceeds 0.25 of the maximum value after time $t_{0.25}$. Therefore all coefficients can be scaled by a factor of 2 and all coefficients for taps corresponding to times after $t_{0.25}$ can be scaled a factor of 4.

The echo cancellation unit provides three parameters for scaling coefficients. The first parameter (GS) determines a scale for all coefficients. The second parameter (FB) determines the first block for which an additional scale (PS) takes effect.

This feature can be used for different default settings like large or small rooms.

2.1.3 Echo Suppression

The echo suppression unit can be in one of three states:

- transmit state
- receive state
- idle state

In transmit state the microphone signal drives the line output while the line input is attenuated. In receive state the loudspeaker signal is driven by the line input while the microphone signal is attenuated. In idle state both signal paths are active with evenly distributed attenuation.

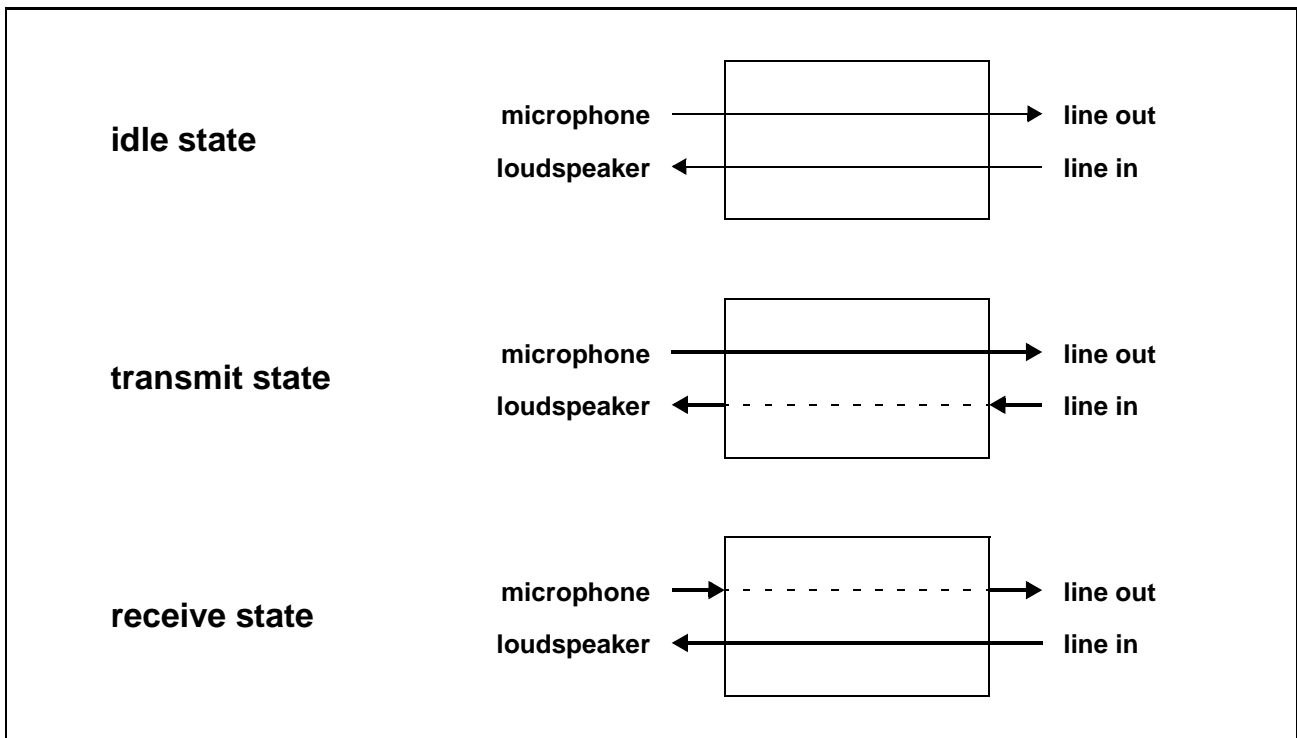

Figure 14 Echo Suppression Unit - States of Operation

Functional Description

Figure 15 shows the signal flow graph of the echo suppression unit in more detail.

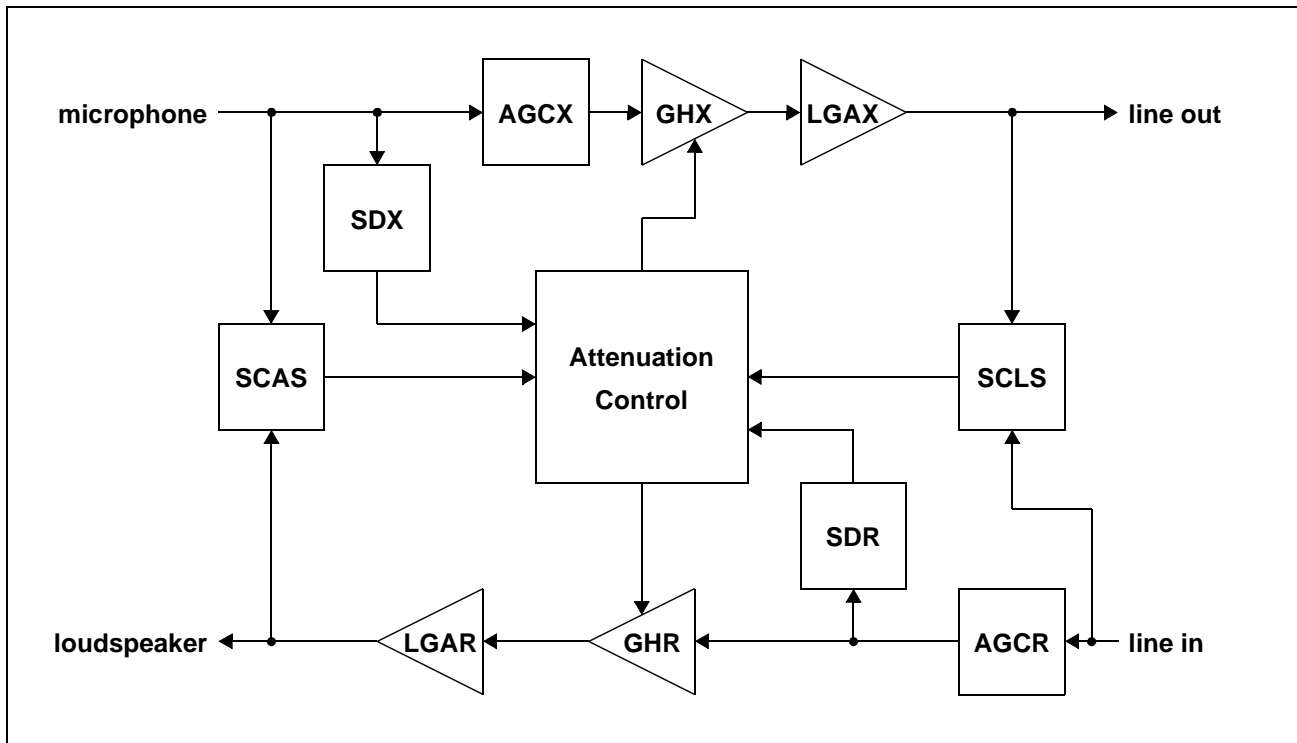

Figure 15 Echo Suppression Unit - Signal Flow Graph

State switching is controlled by the speech comparators (SCAS, SCLS) and the speech detectors (SDX, SDR). The amplifiers (AGCX, AGCR, LGAX, LGAR) are used to achieve proper signal levels for each state. All blocks are programmable. Thus the telephone set can be optimized and adjusted to the particular geometrical and acoustical environment. The following sections discuss each block of the echo suppression unit in detail.

Functional Description

2.1.3.1 Speech Detector

For each signal source a speech detector (SDX, SDR) is available. The speech detectors are identical but can be programmed individually. Figure 16 shows the signal flow graph of a speech detector.

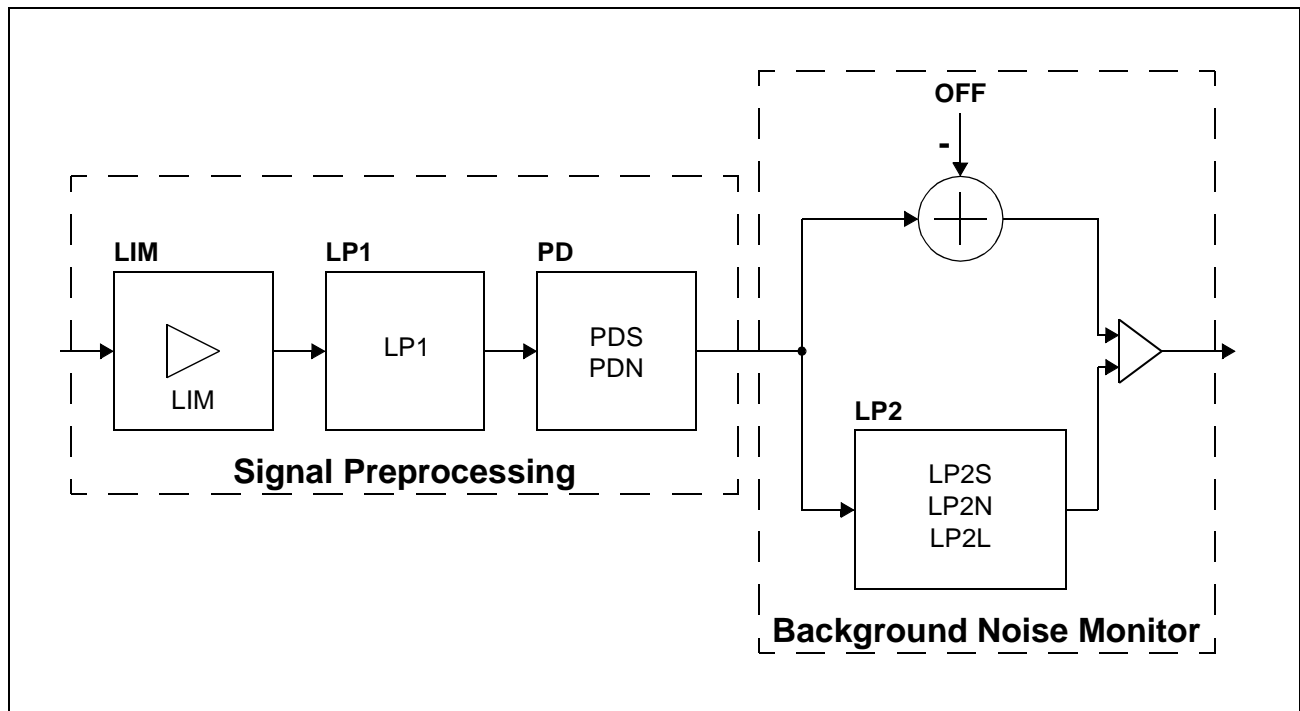

Figure 16 Speech Detector - Signal Flow Graph

The first three units (LIM, LP1, PD) are used for preprocessing the signal while the actual speech detection is performed by the background noise monitor.

Background Noise Monitor

The tasks of the noise monitor are to differentiate voice signals from background noise, even if it exceeds the voice level, and to recognize voice signals without any delay. Therefore the Background Noise Monitor consists of the Low-Pass Filter 2 (LP2) and the offset in two separate branches. Basically it works on the burst-characteristic of the speech: voice signals consist of short peaks with high power (bursts). In contrast, background noise can be regarded approximately stationary from its average power.

Low-Pass Filter 2 provides different time constants for noise (non-detected speech) and speech. It determines the average of the noise reference level. In case of background noise the level at the output of LP2 is approximately the level of the input. As in the other branch an additional offset OFF is added to the signal, the comparator signals noise. At speech bursts the digital signals arriving at the comparator via the offset branch change faster than those via the LP2-branch. If the difference exceeds the offset OFF, the

Functional Description

comparator signals speech. Therefore the output of the background noise monitor is a digital signal indicating speech (1) or noise (0).

A small fade constant (LP2N) enables fast settling of LP2 to the average noise level after the end of speech recognition. However, a too small time constant for LP2N can cause rapid charging to such a high level that after recognizing speech the danger of an unwanted switching back to noise exists. It is recommended to choose a large rising constant (LP2S) so that speech itself charges the LP2 very slowly. Generally, it is not recommended to choose an infinite LP2S because then approaching the noise level is disabled. During continuous speech or tones the LP2 will be charged until the limitation LP2L is reached. Then the value of LP2 is frozen until a break discharges the LP2. This limitation permits transmission of continuous tones and “music on hold”.

The offset stage represents the estimated difference between the speech signal and averaged noise.

Signal Preprocessing

As described in the preceding chapter, the background noise monitor is able to discriminate between speech and noise. In very short speech pauses e.g. between two words, however, it changes immediately to non-speech, which is equal to noise. Therefore a peak detection is required in front of the Noise Monitor.

The main task of the Peak Detector (PD) is to bridge the very short speech pauses during a monolog so that this time constant has to be long. Furthermore, the speech bursts are stored so that a sure speech detection is guaranteed. But if no speech is recognized the noise low-pass LP2 must be charged faster to the average noise level. In addition, the noise edges are to be smoothed. Therefore two time constants are necessary. As the peak detector is very sensitive to spikes, the low-pass LP1 filters the incoming signal containing noise in a way that main spikes are eliminated. Due to the programmable time constant it is possible to refuse high-energy sibilants and noise edges.

To compress the speech signals in their amplitudes and to ease the detection of speech, the signals have to be companded logarithmically. Hereby, the speech detector should not be influenced by the system noise which is always present but should discriminate between speech and background noise. The limitation of the logarithmic amplifier can be programmed via the parameter LIM. LIM is related to the maximum PCM level. A signal exceeding the limitation defined by LIM is getting amplified logarithmically, while very smooth system noise below is neglected. It should be the level of the minimum system noise which is always existing; in the transmit path the noise generated by the telephone circuitry itself and in receive direction the level of the first bit which is stable without any speech signal at the receive path. Table 6 shows the parameters for the speech detector.

Functional Description

Table 4 Speech Detector Parameters

Parameter	# of bytes	Range	Comment
LIM	1	0 to 95 dB	Limitation of log. amplifier
OFF	1	0 to 95 dB	Level offset up to detected noise
PDS	1	1 to 2000 ms	Peak decrement PD1 (speech)
PDN	1	1 to 2000 ms	Peak decrement PD1 (noise)
LP1	1	1 to 2000 ms	Time constant LP1
LP2S	1	2 to 250 s	Time constant LP2 (speech)
LP2N	1	1 to 2000 ms	Time constant LP2 (noise)
LP2L	1	0 to 95 dB	Maximum value of LP2

The input signal of the speech detector can be connected to either the input signal of the echo suppression unit (as shown for SDX) or the output of the associated AGC (as shown for SDR).

Functional Description

2.1.3.2 Speech Comparators (SC)

The echo suppression unit has two identical speech comparators (SCAS, SCLS). Each comparator can be programmed individually to accommodate the different system characteristics of the acoustic interface and the line interface. As SCAS and SCLS are identical, the following description holds for both SCAS and SCLS.

The SC has two input signals SX and SR, which map to microphone/loudspeaker for SCAS and line in/line out for SCLS.

In principle, the SC works according to the following equation:

$$\text{if } SX > SR + V \text{ then switch state}$$

Therefore, SCAS controls the switching to transmit state and SCLS controls the switching to receive state. Switching is done only if SX exceeds SR by at least the expected acoustic level enhancement V which is divided into two parts: G and GD. A block diagram of the SC is shown in figure 17.

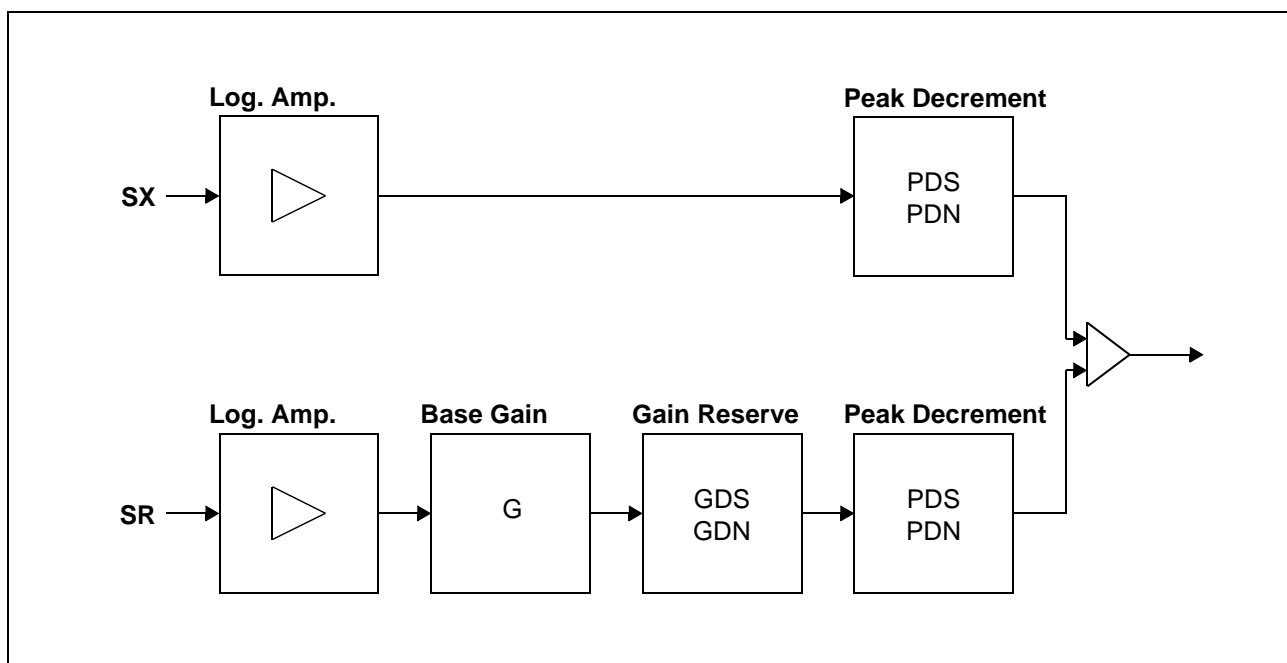

Figure 17 Speech Comparator - Block Diagram

At both inputs, logarithmic amplifiers compress the signal range. Hence after the required signal processing for controlling the acoustic echo, pure logarithmic levels on both paths are compared.

The main task of the comparator is to control the echo. The internal coupling due to the direct sound and mechanical resonances are covered by G. The external coupling, mainly caused by the acoustic feedback, is controlled by GD/PD.

Functional Description

The base gain (G) corresponds to the terminal couplings of the complete telephone: G is the measured or calculated level enhancement between both receive and transmit inputs of the SC.

To control the acoustic feedback two parameters are necessary: GD represents the actual reserve on the measured G. Together with the Peak Decrement (PD) it simulates the echo behavior at the acoustic side: After speech has ended there is a short time during which hard couplings through the mechanics and resonances and the direct echo are present. Till the end of that time (Δt) the level enhancement V must be at least equal to G to prevent clipping caused by these internal couplings. Then, only the acoustic feedback is present. This coupling, however, is reduced by air attenuation. For this in general the longer the delay, the smaller the echo being valid. This echo behavior is featured by the decrement PD.

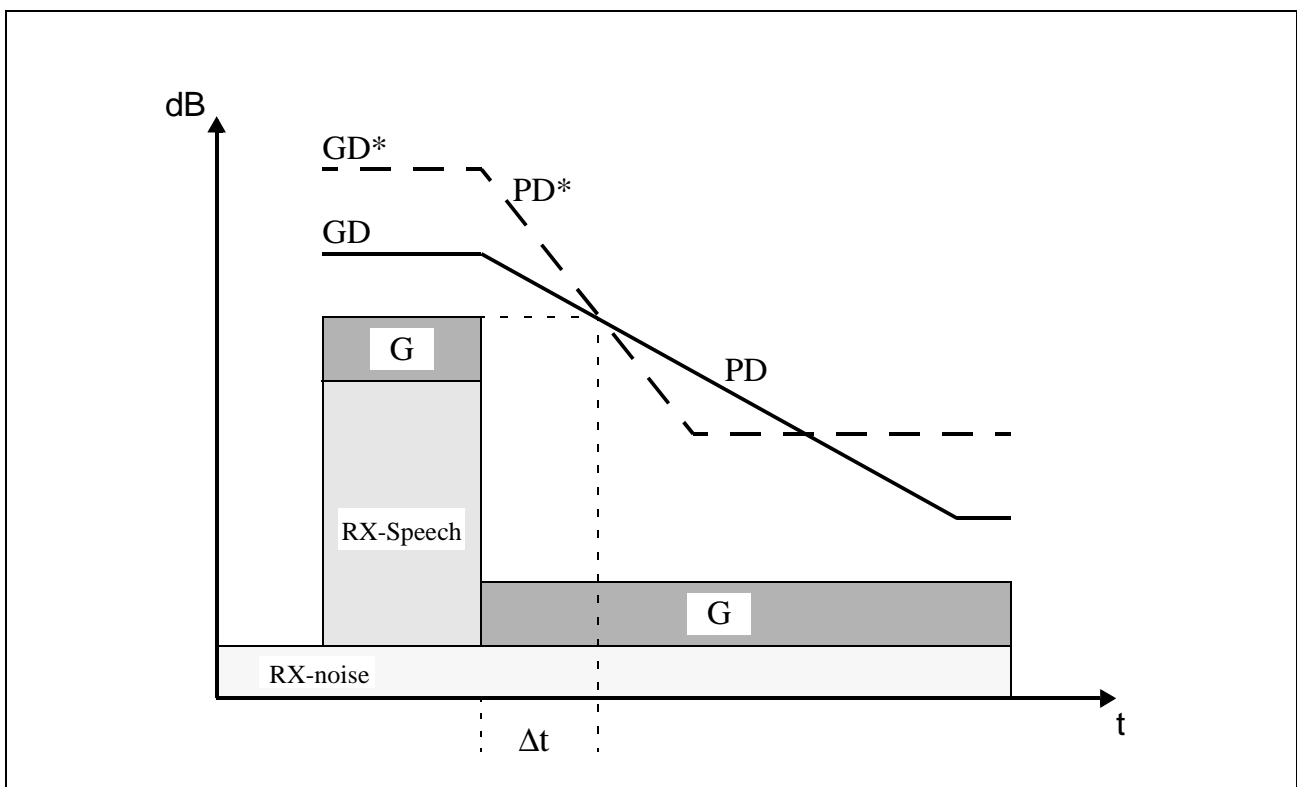

Figure 18 Speech Comparator - Interdependence of Parameters

According to figure 18, a compromise between the reserve GD and the decrement PD has to be made: a smaller reserve (GD) above the level enhancement G requires a longer time to decrease (PD). It is easy to overshoot the other side but the intercommunication is harder because after the end of the speech, the level of the estimated echo has to be exceeded. In contrary, with a higher reserve (GD*) it is harder to overshoot continuous speech or tones, but it enables a faster intercommunication because of a stronger decrement (PD*).

Functional Description

Two pairs of coefficients, GDS/PDS when speech is detected, and GDN/PDN in case of noise, offer a different echo handling for speech and non-speech.

With speech, even if very strong resonances are present, the performance will not be worsened by the high GDS needed. Only when speech is detected, a high reserve prevents clipping. A time period ET [ms] after speech end, the parameters of the comparator are switched to the “noise” values. If both sets of the parameters are equal, ET has no function.

Table 5 Speech Comparator Parameters

Parameter	# of bytes	Range	Comment
G	1	– 48 to + 48 dB	Base Gain
GDS	1	0 to 48 dB	Gain Reserve (Speech)
PDS	1	0.025 to 6 dB/ms	Peak Decrement (Speech)
GDN	1	0 to 48 dB	Gain Reserve (Noise)
PDN	1	0.025 to 6 dB/ms	Peak Decrement (Noise)
ET	1	0 to 992 ms	Time to Switch from speech to noise parameters

2.1.3.3 Attenuation Control

The attenuation control unit controls the attenuation stages GHX and GHR and performs state switching. The programmable attenuation ATT is completely switched to GHX (GHR) in receive state (transmit state). In idle state both GHX and GHR attenuate by ATT/2.

In addition, attenuation is also influenced by the automatic gain control stages (AGCX, AGCR).

State switching depends on the signals of one speech comparator and the corresponding speech detector. While each state is associated with the programmed attenuation, the time it takes to reach the steady-state attenuation after a state switch can be programmed (T_{SW}).

If the current state is either transmit or receive and no speech on either side has been detected for time T_W then idle state is entered. To smoothen the transition, the attenuation is incremented (decremented) by DS until the evenly distributed ATT/2 for both GHX and GHR is reached.

Table 6 shows the parameters for the attenuation unit. Note that T_{SW} is dependent on the current attenuation by the formula $T_{sw} = SW \times ATT$.

Table 6 Attenuation Control Unit Parameters

Parameter	# of bytes	Range	Comment
TW	1	16 ms to 4 s	T_W to return to idle state
ATT	1	0 to 95 dB	Attenuation for GHX and GHR
DS	1	0.6 to 680 ms/dB	Decay Speed (to idle state)
SW	1	0.0052 to 10 ms/dB	Decay Rate (used for T_{SW})

Note: In addition, attenuation is also influenced by the Automatic Gain Control stages (AGCX, AGCR) in order to keep the total loop attenuation constant.

2.1.3.4 Echo Suppression Status Output

The PSB 4860 can report the current state of the echo suppression unit to ease optimization of the parameter set of the echo suppression unit. In this case the SPS_0 and SPS_1 pins are set according to table 7.

Table 7 SPS Output Encoding

SPS_0	SPS_1	Echo Suppression Unit State
0	0	no echo suppression operation
0	1	receive
1	0	transmit
1	1	idle

Furthermore the controller can read the current value of the SPS pins by reading register SPSCCTL.

2.1.3.5 Loudhearing

The speakerphone unit can also be used for controlled loudhearing. If enabled in loudhearing mode, the loudspeaker amplifier of the PSB 4851 (ALS) is used instead of GHR (figure 15) when appropriate to avoid oscillation. In order to enable this feature, the PSB 4851 must be programmed to allow ALS override. The ALS field within the AFE control register AFECTL defines the value sent to the PSB 4851 if attenuation is necessary (see specification of the PSB 4851).

2.1.3.6 Automatic Gain Control

The echo suppression unit has two identical automatic gain control units (AGCX, AGCR).

Functional Description

Operation of the AGC depends on a threshold level defined by the parameter COM (value relative to the maximum PCM-value). The regulation speed is controlled by SPEEDH for signal amplitudes above the threshold and SPEEDL for amplitudes below. Usually SPEEDH will be chosen to be at least 10 times faster than SPEEDL. The bold line in Figure 19 depicts the steady-state output level of the AGC as a function of the input level.

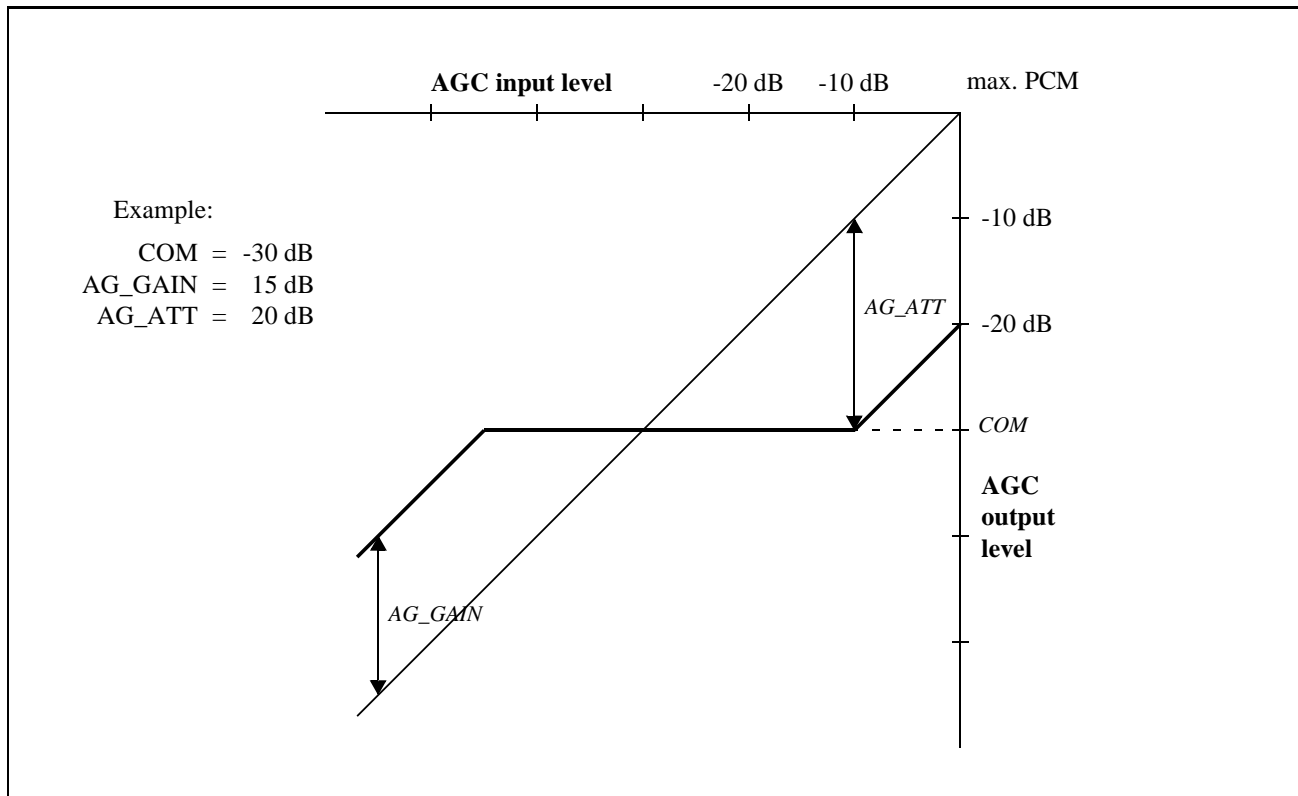

Figure 19 Echo Suppression Unit - Automatic Gain Control

For reasons of physiological acceptance the AGC gain is automatically reduced in case of continuous background noise (e.g. by ventilators). The reduction is programmed via the NOIS parameter. When the noise level exceeds the threshold determined by NOIS, the amplification will be reduced by the same amount the noise level is above the threshold. The current gain/attenuation of the AGC can be read at any time (AG_CUR). An additional low pass with time constant LP is provided to avoid an immediate response of the AGC to very short signal bursts.

If SDX detects noise, AGCX is not working. In this case the last gain setting is used. Regulation starts with this value as soon as SDX detects speech.

Likewise, if SDR detects noise, AGCR is not working. In this case the last gain setting is used. Regulation starts with this value as soon as SDR detects speech. When the AGC has been disabled the initial gain used immediately after enabling the AGC can be programmed. Table 8 shows the parameters of the AGC.

Functional Description

Table 8 Automatic Gain Control Parameters

Parameter	# of Bytes	Range	Comment
AG_INIT	1	-95 dB to 95dB	Initial AGC gain/attenuation
COM	1	0 to – 95 dB	Compare level rel. to max. PCM-value
AG_ATT	1	0 to -95 dB	Attenuation range
AG_GAIN	1	0 to 95 dB	Gain range
AG_CUR	1	-95 dB to 95 dB	Current gain/attenuation
SPEEDL	1	0.25 to 62.5 dB/s	Change rate for lower levels
SPEEDH	1	0.25 to 62.5 dB/s	Change rate for higher levels
NOIS	1	0 to – 95 dB	Threshold for AGC-reduction by background noise
LP	1	0.025 to 16 ms	AGC low pass time constant

Note: There are two sets of parameters, one for AGCX and one for AGCR.

Note: By setting AG_GAIN to 0 dB a limitation function can be realized with the AGC.

2.1.3.7 Fixed Gain

Each signal path features an additional amplifier (LGAX, LGAR) that can be set to a fixed gain. These amplifiers should be used for the basic amplification in order to avoid saturation in the preceding stages. Table 9 shows the only parameter of this stage.

Table 9 Fixed Gain Parameters

Parameter	# of Bytes	Range	Comment
LGA	1	-12 dB to 12 dB	always active

2.1.3.8 Mode Control

Table 10 shows the registers used to determine the signal sources and the mode.

Table 10 Speakerphone Control Registers

Register	# of Bits	Name	Comment
SCTL	1	ENS	Echo suppression unit enable
SCTL	1	ENC	Echo cancellation unit enable
SCTL	1	MD	Speakerphone or loudhearing mode
SCTL	1	AGX	AGCX enable

Functional Description

Table 10 Speakerphone Control Registers

SCTL	1	AGR	AGCR enable
SCTL	1	SDX	SDX input tap
SCTL	1	SDR	SDR input tap
AFECTL	4	ALS	ALS value for loudhearing
SSRC1	5	I1	Input signal 1 (microphone)
SSRC1	5	I2	Input signal 2 (microphone)
SSRC2	5	I3	Input signal 3 (line in)
SSRC2	5	I4	Input signal 4 (line in)

Functional Description

2.1.4 Line Echo Canceller

The PSB 4860 contains an adaptive line echo cancellation unit for the cancellation of near end echoes. The unit has two modes: normal and extended. In normal mode, the maximum echo length is 4 ms. This mode is always available. In extended mode, the maximum echo length is 24 ms. Extended mode cannot be used while the speech encoder, the echo cancellation unit or slow playback is active.

The line echo cancellation unit is especially useful in front of the various detectors (DTMF, CPT, etc.). A block diagram is shown in figure 20.

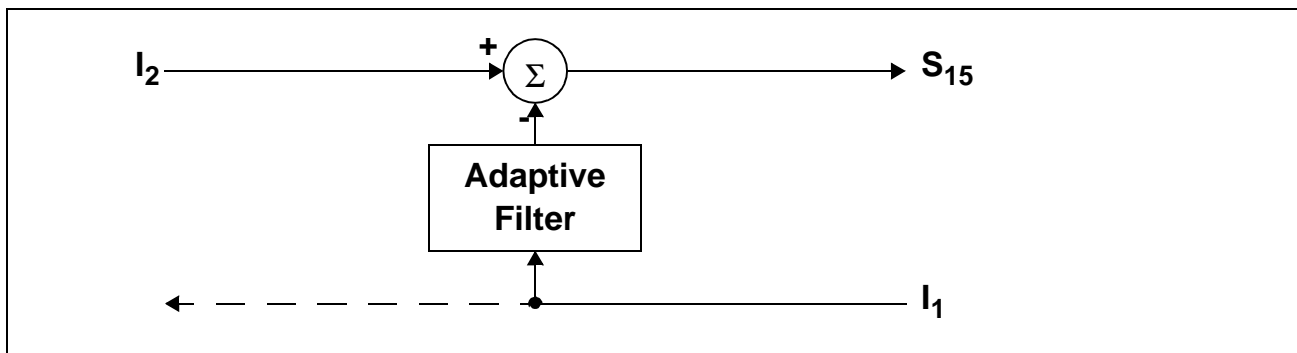

Figure 20 Line Echo Cancellation Unit - Block Diagram

The line echo canceller provides only one outgoing signal (S_{15}) as the other outgoing signal would be identical with the input signal I_1 .

Input I_2 is usually connected to the line input while input I_1 is connected to the outgoing signal.

In normal mode the adaption process can be controlled by three parameters: MIN, ATT and MGN. Adaption takes only place if both of the following conditions hold:

1. $I_1 > \text{MIN}$
2. $I_1 - I_2 - \text{ATT} + \text{MGN} > 0$

With the first condition adaption to small signals can be avoided. The second condition avoids adaption during double talk. The parameter ATT represents the echo loss provided by external circuitry. The adaption stops if the power of the received signal (I_2) exceeds the power of the expected signal ($I_1 - \text{ATT}$) by more than the margin MGN.

Functional Description

Table 11 shows the registers associated with the line echo canceller.

Table 11 Line Echo Cancellation Unit Registers

Register	# of Bits	Name	Comment	Relevant Mode
LECCTL	1	EN	Line echo canceller enable	both
LECCTL	1	MD	Line echo canceller mode	
LECCTL	5	I2	Input signal selection for I ₂	both
LECCTL	5	I1	Input signal selection for I ₁	both
LECLEV	15	MIN	Minimal power for signal I ₁	normal
LECATT	15	ATT	Externally provided attenuation (I ₁ to I ₂)	normal
LECMGN	15	MGN	Margin for double talk detection	normal

Functional Description

2.1.5 DTMF Detector

Figure 21 shows a block diagram of the DTMF detector. The results of the detector are available in the status register and a dedicated result register that can be read via the serial control interface (SCI) by the external controller. All sixteen standard DTMF tones are recognized.

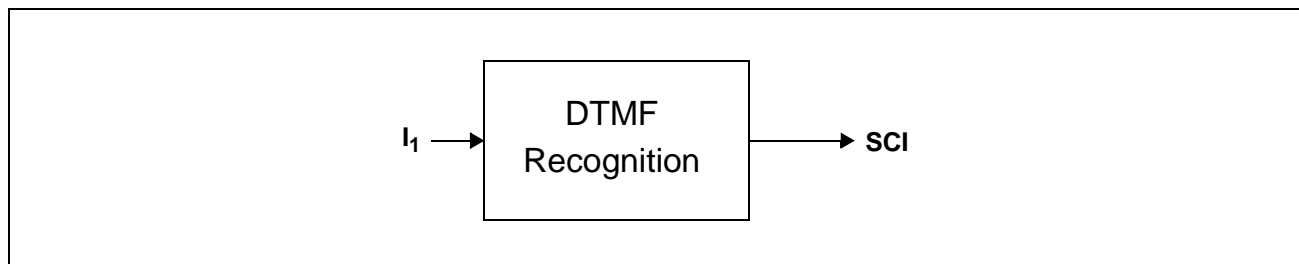

Figure 21 DTMF Detector - Block Diagram

Table 12 to 14 show the associated registers.

Table 12 DTMF Detector Control Register

Register	# of Bits	Name	Comment
DDCTL	1	EN	DTMF detector enable
DDCTL	5	I1	Input signal selection

As soon as a valid DTMF tone is recognized, the status word and the DTMF tone code are updated (table 13).

Table 13 DTMF Detector Results

Register	# of Bits	Name	Comment
STATUS	1	DTV	DTMF code valid
DDCTL	5	DTC	DTMF tone code

DTV is set when a DTMF tone is recognized and reset when no DTMF tone is recognized or the detector is disabled. The code for the DTMF tone is placed into the register DDCTL. The registers DDTW and DDLEV hold parameters for detection (table 14).

Table 14 DTMF Detector Parameters

Register	# of Bits	Name	Comment
DDTW	15	TWIST	Twist for DTMF recognition
DDLEV	6	MIN	Minimum signal level to detect DTMF tones

Functional Description

2.1.6 CNG Detector

The calling tone (CNG) detector can detect the standard calling tones of fax machines or modems. This helps to distinguish voice messages from data transfers. The result of the detector is available in the status register that can be read via the serial control interface (SCI) by the external controller. The CNG detector consists of two band-pass filters with fixed center frequency of 1100 Hz and 1300 Hz.

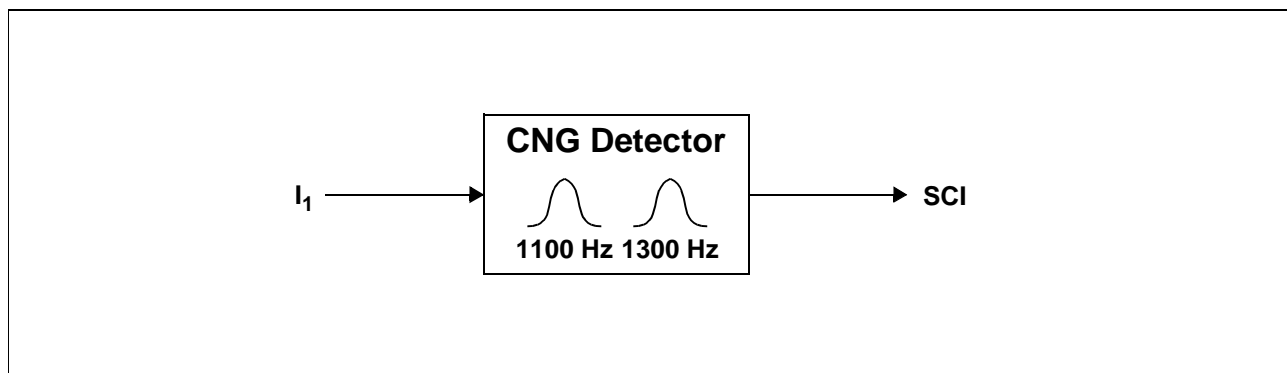

Figure 22 CNG Detector - Block Diagram

Table 15 shows the available parameters.

Table 15 CNG Detector Registers

Register	# of Bits	Name	Comment
CNGCTL	1	EN	CNG detector enable
CNGCTL	5	I1	Input signal selection
CNGLEV	16	MIN	Minimum signal level
CNGBT	16	TIME	Minimum time of signal burst
CNGRES	16	RES	Input signal resolution

Both the programmed minimum time and the minimum signal level must be exceeded for a valid CNG tone. Furthermore the input signal resolution can be reduced by the RES parameter. This can be useful in a noisy environment at low signal levels although the accuracy of the detection decreases. As soon as a valid tone is recognized, the status word of the PSB 4860 is updated. The status bits are defined as follows:

Table 16 CNG Detector Result

Register	# of Bits	Name	Comment
STATUS	1	CNG	Fax/Modem calling tone detected

2.1.7 Alert Tone Detector

The alert tone detector can detect the standard alert tones (2130 Hz and 2750 Hz) for caller id protocols. The results of the detector are available in the status register and the dedicated register ATDCTL0 that can be read via the serial control interface (SCI) by the external controller.

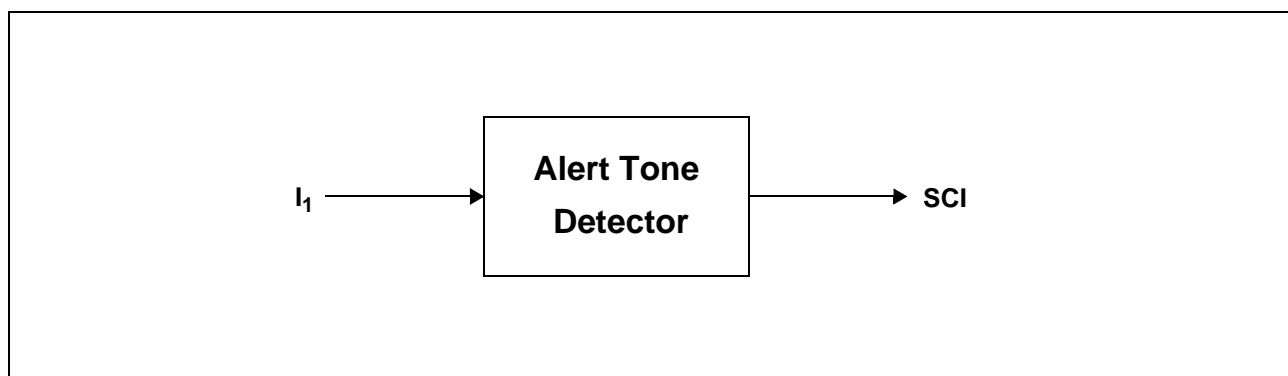

Figure 23 Alert Tone Detector - Block Diagram

Table 17 Alert Tone Detector Registers

Register	# of Bits	Name	Comment
ATDCTL0	1	EN	Alert Tone Detector Enable
ATDCTL0	5	I1	Input signal selection
ATDCTL1	1	MD	Detection of dual tones or single tones
ATDCTL1	1	DEV	Maximum deviation (0.5% or 1.1%)
ATDCTL1	8	MIN	Minimum signal level to detect alert tones

As soon as a valid alert tone is recognized, the status word of the PSB 4860 and the code for the detected combination of alert tones are updated (table 18).

Table 18 Alert Tone Detector Results

Register	# of Bits	Name	Comment
STATUS	1	ATV	Alert tone detected
ATDCTL0	2	ATC	Alert tone code

Functional Description

2.1.8 CPT Detector

The selected signal is monitored continuously for a call progress tone. The CPT detector consists of a band-pass and an optional timing checker (figure 24).

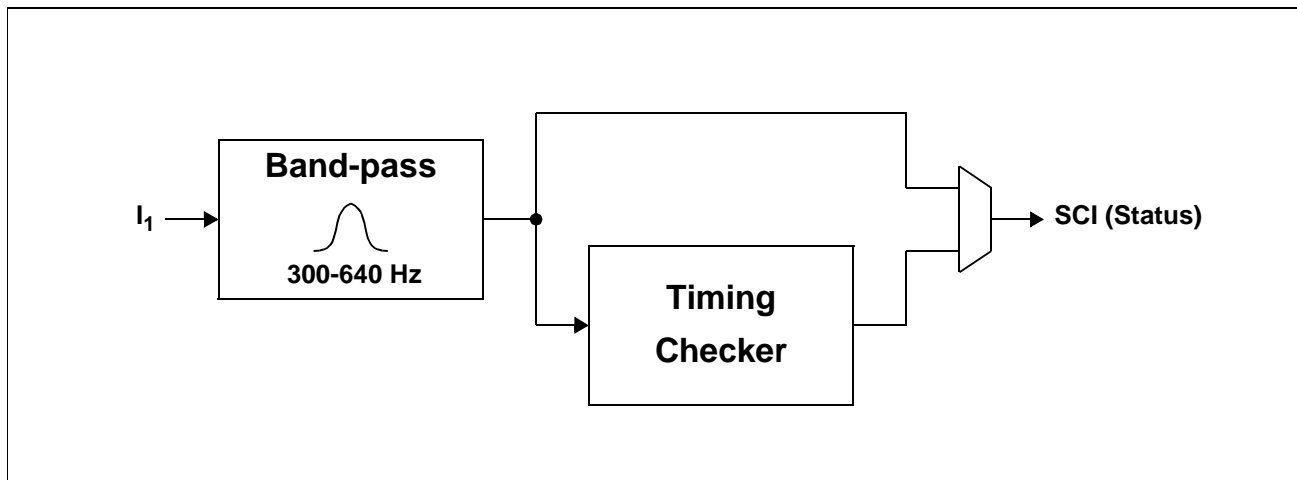

Figure 24 CPT Detector - Block Diagram

The CPT detector can be used in two modes: raw and cooked. In raw mode, the occurrence of a signal within the frequency range, time and energy limits is directly reported. The timing checker is bypassed and therefore the PSB 4860 does not interpret the length or interval of the signal.

In cooked mode, the number and duration of signal bursts are interpreted by the timing checker. A signal burst followed by a gap is called a cycle. Cooked mode requires a minimum of two cycles. The CPT flag is set with the first burst after the programmed number of cycles has been detected. The CPT flag remains set until the unit is disabled, even if the conditions are not met anymore. In this mode the CPT is modelled as a sequence of identical bursts separated by gaps with identical length. The PSB 4860 can be programmed to accept a range for both the burst and the gap. It is also possible to specify a maximum aberration of two consecutive bursts and gaps. Figure 25 shows the parameters for a single cycle (burst and gap).

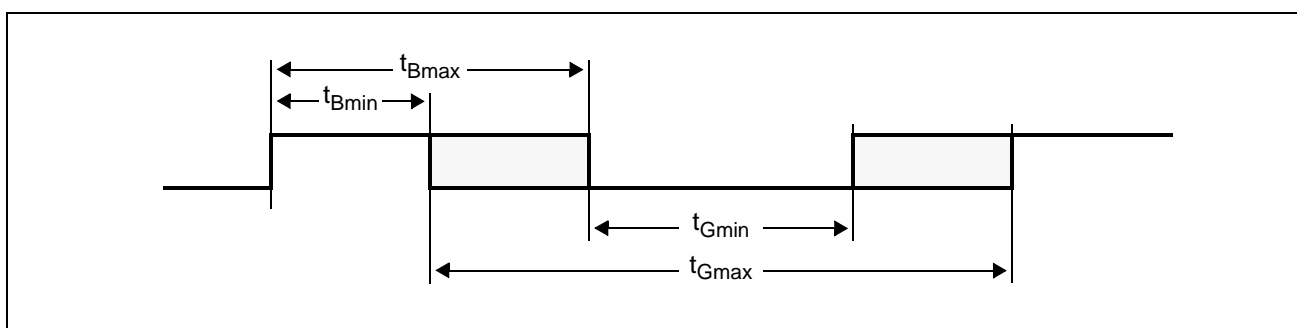

Figure 25 CPT Detector - Cooked Mode

The status bit is defined as follows:

Functional Description

Table 19 CPT Detector Result

Register	# of Bits	Name	Comment
STATUS	1	CPT	CP tone currently detected [340 Hz; 640 Hz]

CPT is not affected by reading the status word. It is automatically reset when the unit is disabled. Table 20 shows the control register for the CPT detector.

Table 20 CPT Detector Registers

Register	# of Bits	Name	Comment
CPTCTL	1	EN	Unit enable
CPTCTL	1	MD	Mode (cooked, raw)
CPTCTL	5	I1	Input signal selection
CPTMN	8	MINB	Minimum time of a signal burst (t_{Bmin})
CPTMN	8	MING	Minimum time of a signal gap (t_{Gmin})
CPTMX	8	MAXB	Maximum time of a signal burst (t_{Bmax})
CPTMX	8	MAXG	Maximum time of a signal gap (t_{Gmax})
CPTDT	8	DIFB	Maximum difference between consecutive bursts
CPTDT	8	DIFG	Maximum difference between consecutive gaps
CPTTR	3	NUM	Number of cycles (cooked mode), 0 (raw mode)
CPTTR	8	MIN	Minimum signal level to detect tones
CPTTR	4	SN	Minimal signal-to-noise ratio

If any condition is violated during a sequence of cycles the timing checker is reset and restarts with the next valid burst.

Note: In cooked mode CPT is set with the first burst after the programmed number of cycles has been detected.

Note: The number of cycles must be set to zero in raw mode.

Functional Description

2.1.9 Caller ID Decoder

The caller ID decoder is basically a 1200 baud modem (FSK, demodulation only). The bit stream is formatted by a subsequent UART and the data is available in a data register along with status information (figure 26).

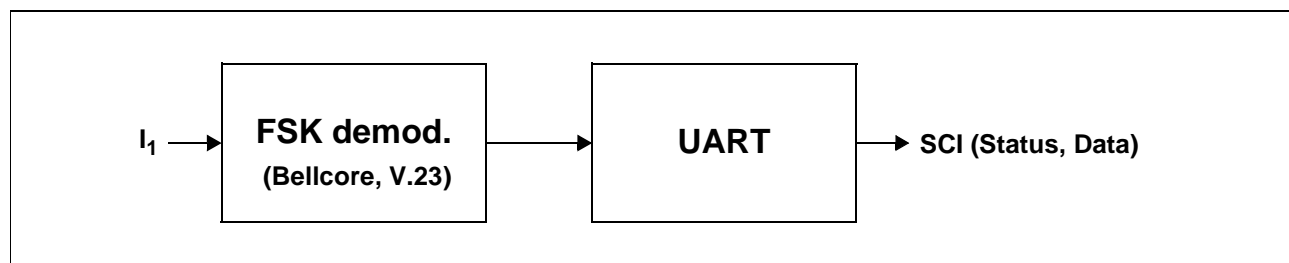

Figure 26 Caller ID Decoder - Block Diagram

The FSK demodulator supports two modes according to table 21. The appropriate mode is detected automatically.

Table 21 Caller ID Decoder Modes

Mode	Mark (Hz)	Space (Hz)	Comment
1	1200	2200	Bellcore
2	1300	2100	V.23

The CID decoder does not interpret the data received. Each byte received is placed into the CIDCTL register (table 23). The status byte of the PSB 4860 is updated (table 22).

Table 22 Caller ID Decoder Status

Register	# of Bits	Name	Comment
STATUS	1	CIA	CID byte received
STATUS	1	CD	Carrier Detected

CIA and CD are cleared when the unit is disabled. In addition, CIA is cleared when CIDCTL0 is read.

Table 23 Caller ID Decoder Registers

Register	# of Bits	Name	Comment
CIDCTL0	1	EN	Unit enable
CIDCTL0	5	I1	Input signal selection
CIDCTL0	8	DATA	Last CID data byte received

Functional Description

Table 23 Caller ID Decoder Registers

Register	# of Bits	Name	Comment
CIDCTL1	5	NMSS	Number of mark/space sequences necessary for successful detection of carrier detect
CIDCTL1	6	NMB	Number of mark bits necessary before space of first byte after carrier detect
CIDCTL1	5	MIN	Minimum signal level for CID detection

When the CID unit is enabled, it first waits for a channel seizure signal consisting of a series of alternating space and mark signals. The number of spaces and marks that have to be received without errors before the PSB 4860 reports a carrier detect by setting status bit CD can be programmed.

Channel seizure must be followed by at least 16 continuous mark signals. The first space signal detected is then regarded as the start bit of the first message byte.

The interpretation of the data, including message type, length and checksum is completely left to the controller. The CID unit should be disabled as soon as the complete information has been received as it cannot detect the end of the transmission by itself.

Note: Some caller ID mechanism may require additional external components for DC decoupling. These tasks must be handled by the controller.

Note: The controller is responsible for selecting and storing parts of the CID as needed.

Functional Description

2.1.10 DTMF Generator

The DTMF generator can generate single or dual tones with programmable frequency and gain. This unit is primarily used to generate the common DTMF tones but can also be used for signalling or other user defined tones. A block diagram is shown in figure 27.

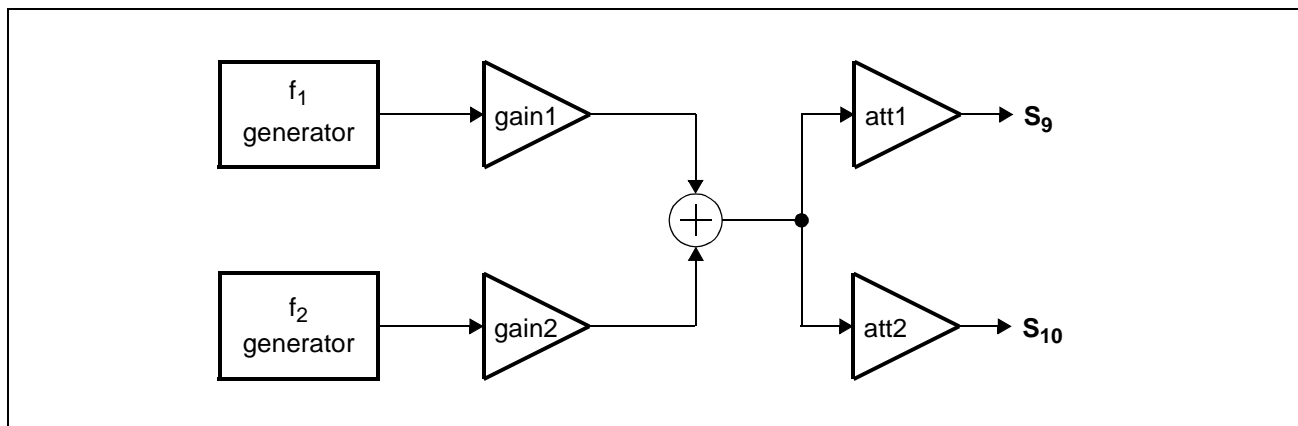

Figure 27 DTMF Generator - Block Diagram

Both generators and amplifiers are identical. There are two modes for programming the generators, cooked mode and raw mode. In cooked mode, the standard DTMF frequencies are generated by programming a single 4 bit code. In raw mode, the frequency of each generator/amplifier can be programmed individually by a separate register. The unit has two outputs which provide the same signal but with individually programmable attenuation. Table 24 shows the parameters of this unit.

Table 24 DTMF Generator Registers

Register	# of Bits	Name	Comment
DGCTL	1	EN	Enable for generators
DGCTL	1	MD	Mode (cooked/raw)
DGCTL	4	DTC	DTMF code (cooked mode)
DGF1	15	FRQ1	Frequency of generator 1
DGF2	15	FRQ2	Frequency of generator 2
DGL	7	LEV1	Level of signal for generator 1
DGL	7	LEV2	Level of signal for generator 2
DGATT	8	ATT1	Attenuation of S ₉
DGATT	8	ATT2	Attenuation of S ₁₀

Note: DGF1 and DGF2 are undefined when cooked mode is used and must not be written.

2.1.11 Speech Coder

The speech coder (figure 28) has two input signals I_1 and I_2 . The first signal (I_1) is fed to the coder while the second signal (I_2) is used as a reference signal for voice controlled recording. The signal I_1 can be coded by either a High Quality coder or a Long Play coder.

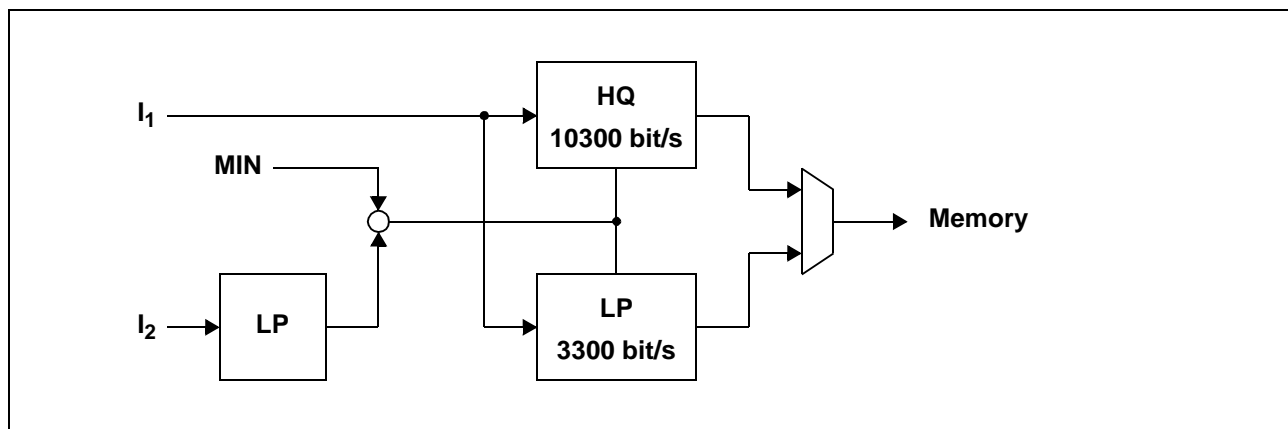

Figure 28 Speech Coder - Block Diagram

In High Quality the output data stream runs at a fixed rate of 10300 bit/s and provides excellent speech quality. In Long Play mode, the output data stream is further reduced to an average of 3300 bit/s while still maintaining good quality.

Data is written starting at the current file pointer and the file pointer is advanced as needed. In case of any memory error (e.g. memory full) a file error is indicated and the coder is disabled. The controller must subsequently close the file.

The coder can be switched on the fly. However, it may take up to 60 ms until the switch is executed. The controller must therefore wait for at least this time until issuing another command that relies on the mode switch. No audio data is lost during switching.

The signal I_2 is first filtered by a low pass LP1 with programmable time constant and then compared to a reference level MIN. If the filtered signal exceeds MIN, then the status bit SD (table 25) is set immediately. If the filtered signal has been smaller than MIN for a programmable time TIME then the status bit SD is reset.

The coder can be enabled in permanent mode or in voice recognition mode. In permanent mode, the coder starts immediately and compresses all input data continuously. The current state of the status bit SD does not affect the coder.

In voice recognition mode, the coder is automatically started on the first transition of the status bit from 0 to 1. Once the coder has started it remains active until disabled.

Table 25 Speech Coder Status

Register	# of Bits	Name	Comment
STATUS	1	SD	Speech detected

Functional Description

The operation of the speech coder is defined according to table 26.

Table 26 Speech Coder Registers

Register	# of Bits	Name	Comment
SCCTL	1	EN	Enable speech coder
SCCTL	1	HQ	High quality mode
SCCTL	1	VC	Voice controlled recording
SCCTL	5	I1	Input signal 1 selection
SCCTL	5	I2	Input signal 2 selection
SCCT2	8	MIN	Minimal signal level for speech detection
SCCT2	8	TIME	Minimum time for reset of SD
SCCT3	8	LP	Time constant for low-pass

Note: The peak data rate in LP mode is 4800 bit/s.

Note: Both HQ and LP mode will not produce identical bit streams after a coding/decoding cycle.

2.1.12 Speech Decoder

The speech decoder (figure 29) decompresses the data previously coded by the speech coder unit and delivers a standard 128 kbit/s data stream.

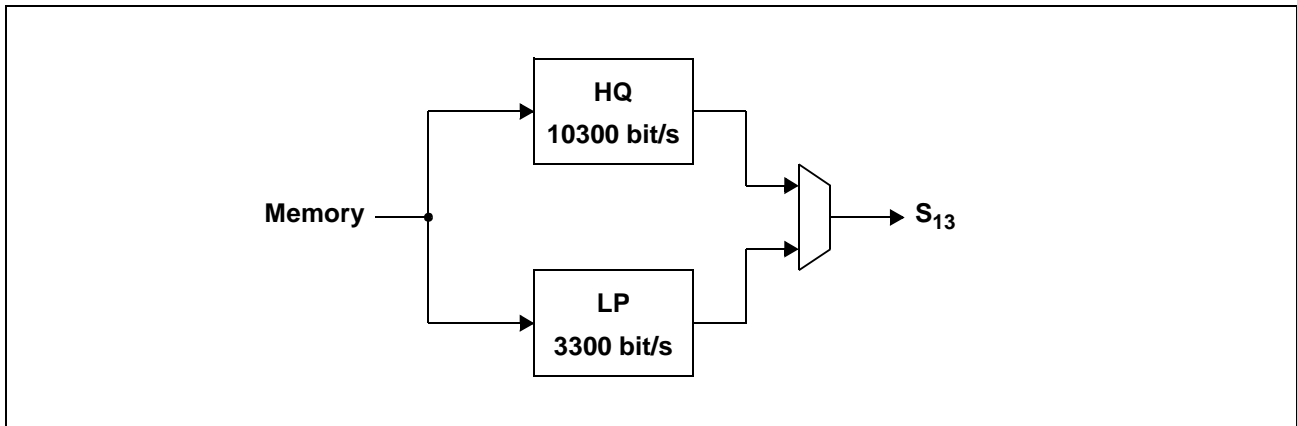

Figure 29 Speech Decoder - Block Diagram

The decoder supports fast (1.5 and 2.0 times) and slow (0.5 times) motion independent of the selected quality. The decoder requests input data as needed at a variable rate. Table 27 shows the signal and mode selection for the speech decoder.

Table 27 Speech Decoder Registers

Register	# of Bits	Name	Comment
SDCTL	1	EN	Enable speech decoder
SDCTL	2	SPEED	Selection of playback speed

Data reading starts at the location of the current file pointer. The file pointer is updated during speech decoding. If the end of the file is reached, the decoder is automatically disabled. The PSB 4860 automatically resets SDCTL:EN at this point.

Functional Description

2.1.13 Analog Front End Interface

There are two identical interfaces at the analog side (to PSB 4851) as shown in figure 30.

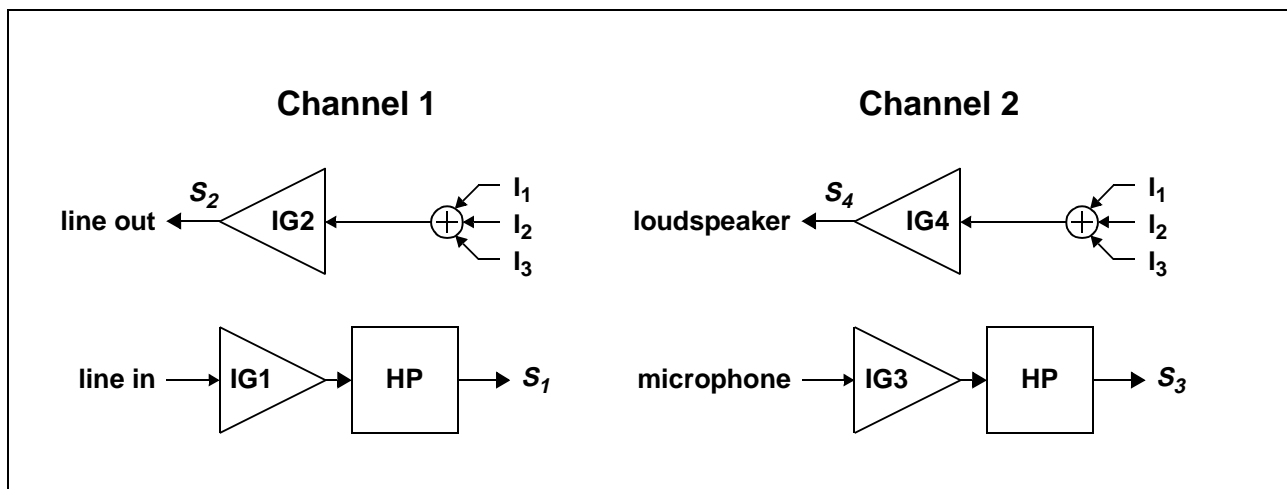

Figure 30 Analog Front End Interface - Block Diagram

For each signal an amplifier is provided for level adjustment. The incoming signals can be passed through an optional high-pass (HP). This high-pass ($f_g=20$ Hz) is useful for blocking DC offsets and should be enabled by default. Furthermore, up to three signals can be mixed in order to generate the outgoing signals (S_2, S_4). Table 28 shows the associated registers.

Table 28 Analog Front End Interface Registers

Register	# of Bits	Name	Comment
IFG1	16	IG1	Gain for IG1
IFG2	16	IG2	Gain for IG2
IFS1	1	HP	High-pass for S_1
IFS1	5	I1	Input signal 1 for IG2
IFS1	5	I2	Input signal 2 for IG2
IFS1	5	I3	Input signal 3 for IG2
IFG3	16	IG3	Gain for IG3
IFG4	16	IG4	Gain for IG4
IFS2	1	HP	High-pass for S_3
IFS2	5	I1	Input signal 1 for IG4
IFS2	5	I2	Input signal 2 for IG4
IFS2	5	I3	Input signal 3 for IG4

Functional Description

2.1.14 Digital Interface

There are two almost identical interfaces at the digital side as shown in figure 31. The only difference between these two interfaces is that only channel 1 supports the SSDI mode.

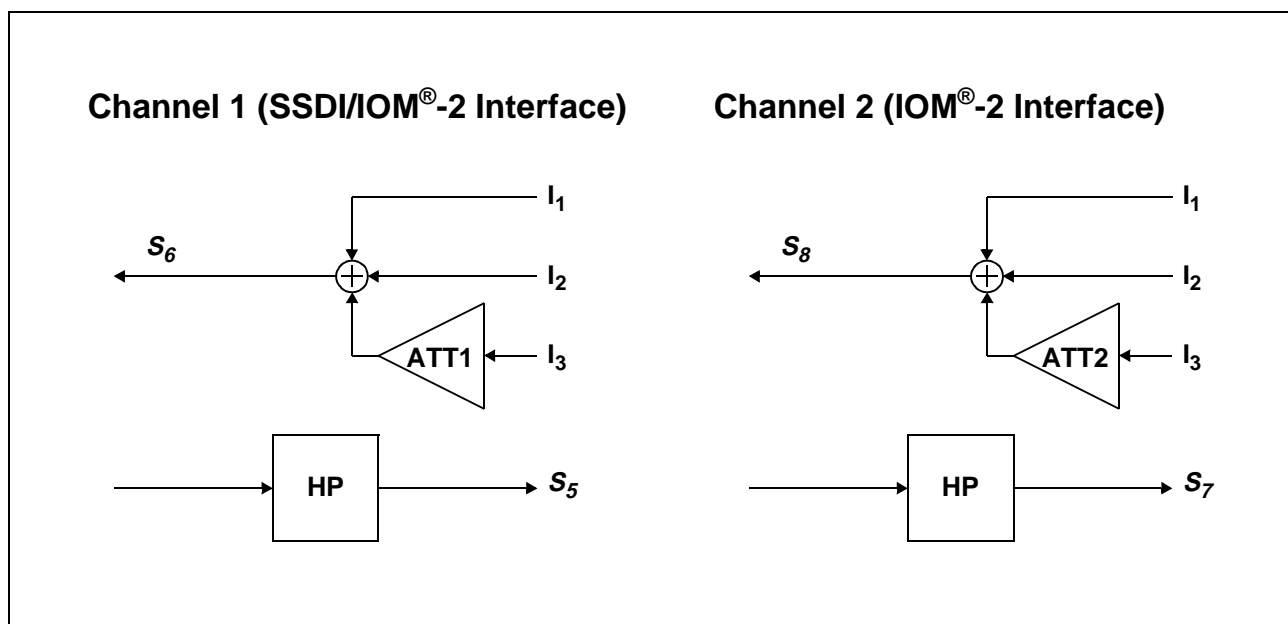

Figure 31 Digital Interface - Block Diagram

Each outgoing signal can be the sum of two signals with no attenuation and one signal with programmable attenuation (ATT). The attenuator can be used for artificial echo if there is none externally provided (e.g. ISDN application). Each input can be passed through an optional high-pass (HP). The associated registers are shown in table 29.

Table 29 Digital Interface Registers

Register	# of Bits	Name	Comment
IFS3	5	I1	Input signal 1 for S ₆
IFS3	5	I2	Input signal 2 for S ₆
IFS3	5	I3	Input signal 3 for S ₆
IFS3	1	HP	High-pass for S ₅
IFS4	5	I1	Input signal 1 for S ₈
IFS4	5	I2	Input signal 2 for S ₈
IFS4	5	I3	Input signal 3 for S ₈
IFS4	1	HP	High-pass for S ₇

Functional Description**Table 29 Digital Interface Registers**

Register	# of Bits	Name	Comment
IFG5	8	ATT1	Attenuation for input signal I3 (Channel 1)
IFG5	8	ATT2	Attenuation for input signal I3 (Channel 2)

Functional Description

2.1.15 Universal Attenuator

The PSB 4860 contains an universal attenuator that can be connected to any signal (e.g. for sidetone gain in ISDN applications).

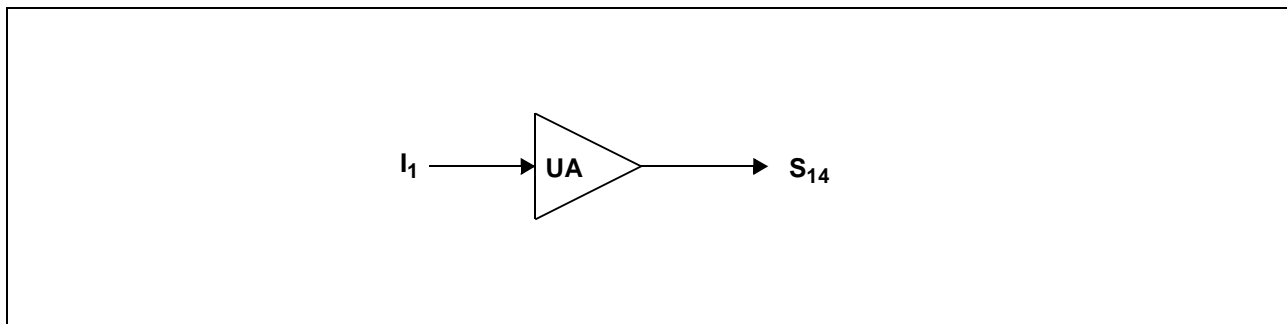

Figure 32 Universal Attenuator - Block Diagram

Table 30 shows the associated register.

Table 30 Universal Attenuator Registers

Register	# of Bits	Name	Comment
UA	8	ATT	Attenuation for UA
UA	5	I1	Input signal for UA

Functional Description

2.1.16 Automatic Gain Control Unit

In addition to the universal attenuator with programmable but fixed gain the PSB 4860 contains an amplifier with automatic gain control (AGC). The AGC is preceded by a signal summation point for two input signals. One of the input signals can be attenuated.

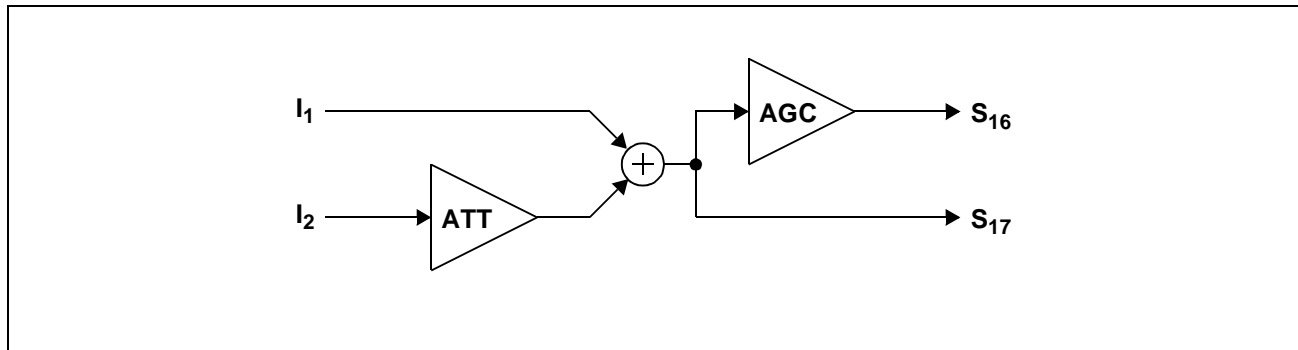

Figure 33 Automatic Gain Control Unit - Block Diagram

Furthermore the signal after the summation point is available. Besides providing a general signal summation (S_{16} not used) this signal is especially useful if the AGC unit provides the input signal for the speech coder. In this case S_{17} can be used as a reference signal for voice controlled recording.

The operation of the AGC is similar to AGCX (ACCR) of the speakerphone. The differences are as follows:

- No NOIS parameter
- Separate enable/disable control
- Slightly different coefficient format

Furthermore the AGC contains a comparator that starts and stops the gain regulation. The signal after the summation point (S_{17}) is filtered by a peak detector with time constant DEC for decay. Then the signal is compared to a programmable limit LIM. Regulation takes only place when the filtered signal exceeds the limit.

Table 31 shows the associated registers.

Table 31 Automatic Gain Control Registers

Register	# of Bits	Name	Comment
AGCCTL	1	EN	Enable
AGCCTL	5	I1	Input signal 1 for AGC
AGCCTL	5	I2	Input signal 2 for AGC
AGCATT	15	ATT	Attenuation for I_2
AGC1	8	AG_INIT	Initial AGC gain/attenuation
AGC1	8	COM	Compare level rel. to max. PCM-value

Functional Description

Table 31 Automatic Gain Control Registers

Register	# of Bits	Name	Comment
AGC2	8	SPEEDL	Change rate for lower levels
AGC2	8	SPEEDH	Change rate for higher level
AGC3	8	AG_ATT	Attenuation range
AGC3	7	AG_GAIN	Gain range
AGC4	7	DEC	Peak detector time constant
AGC4	8	LIM	Comparator minimal signal level
AGC5	7	LP	AGC low pass time constant

Functional Description

2.1.17 Equalizer

The PSB 4860 also provides an equalizer that can be inserted into any signal path. The main application for the equalizer is the adaption to the frequency characteristics of the microphone, transducer or loudspeaker.

The equalizer consists of an IIR filter followed by an FIR filter as shown in figure 34.

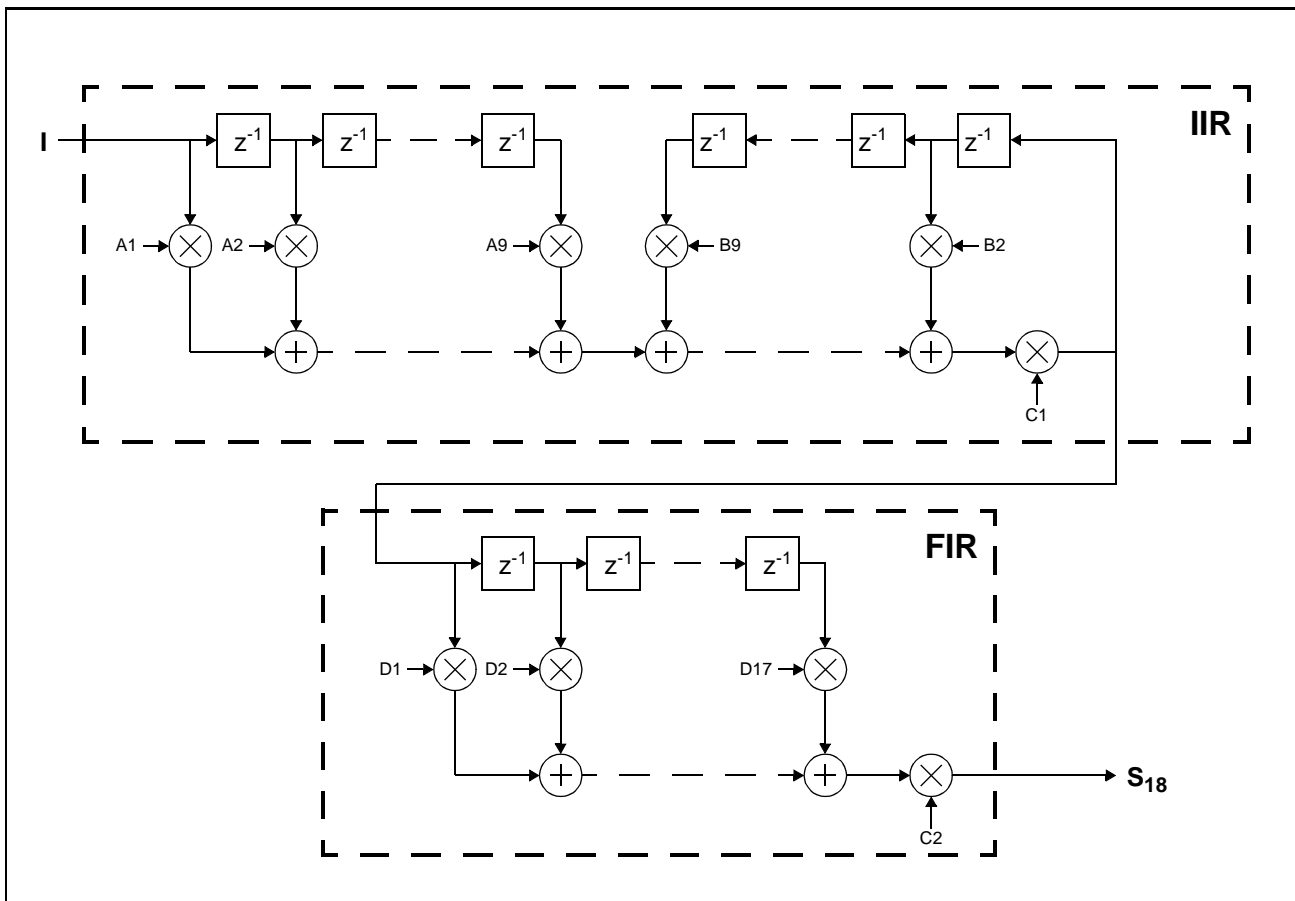

Figure 34 Equalizer - Block Diagram

The coefficients A_1 - A_9 , B_2 - B_9 and C_1 belong to the IIR filter, the coefficients D_1 - D_{17} and C_2 belong to the FIR filter. Table 32 shows the registers associated with the equalizer.

Table 32 Equalizer Registers

Register	# of Bits	Name	Comment
FCFCTL	1	EN	Enable
FCFCTL	5	I	Input signal for equalizer
FCFCTL	6	ADR	Filter coefficient address
FCFCOF	16		Filter coefficient data

Functional Description

Due to the multitude of coefficients the uses an indirect addressing scheme for reading or writing an individual coefficient. The address of the coefficient is given by ADR and the actual value is read or written to register FCFCOF.

In order to ease programming the PSB 4860 automatically increments the address ADR after each access to FCFCOF.

Note: Any access to an out-of-range address automatically resets FCFCTL:ADR.

2.2 Memory Management

This section describes the memory management provided by the PSB 4860. As figure 35 shows, three units can access the external memory. During recording, the speech coder can write compressed speech data into the external memory. For playback, the speech decoder reads compressed speech data from external memory. In addition, the microcontroller can directly access the memory by the SCI interface.

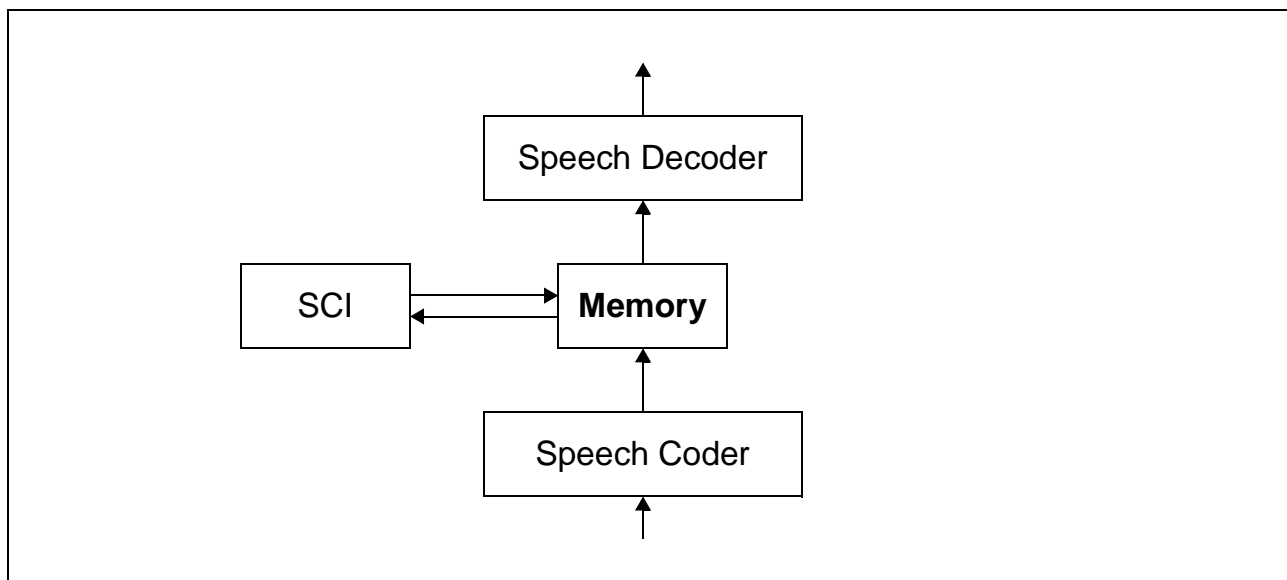

Figure 35 Memory Management - Data Flow

The memory is organized as a file system. For each memory space (R/W-memory and voice prompt memory) the PSB 4860 maintains a directory with 255 file descriptors (figure 36).

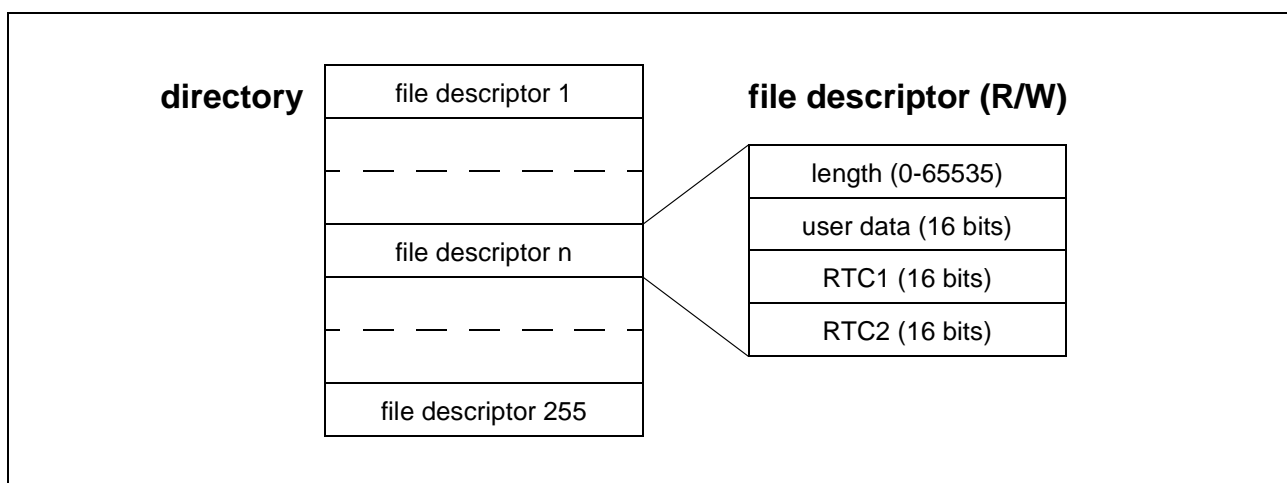

Figure 36 Memory Management - Directory Structure

The directories must be created after each power failure for volatile R/W-memory. All file descriptors are cleared (all words zero). For non-volatile memory, the directories have to

Functional Description

be created only once. If the directories already exist, the memory has just to be activated after a reset. The file descriptors are not changed in this case.

All commands that access the other fields or involve a write access must not be used in voice prompt memory space.

2.2.1 File Definition and Access

A file is a linear sequence of units and can be accessed in two modes: binary and audio. In binary mode, a unit is a word. In audio mode, a unit is a variable number of words representing 30 ms of uncompressed speech. A file can contain at most 65535 units. Figure 37 shows an audio file containing 100 audio units. The length of the message is therefore 3 s.

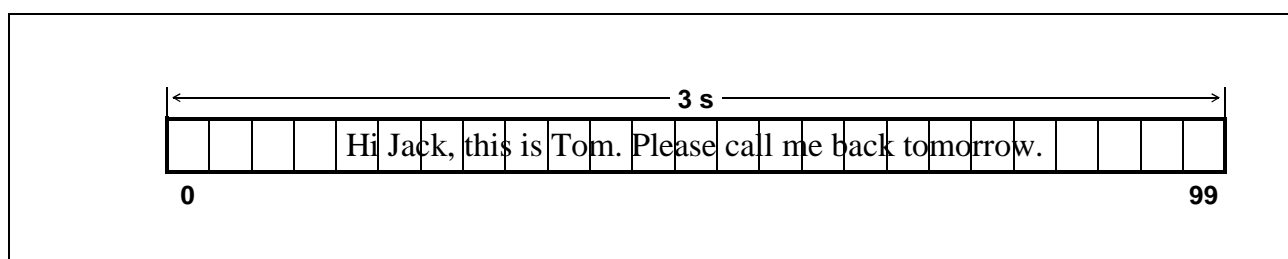

Figure 37 Audio File Organization - Example

Figure 38 shows a binary file of 11 words containing a phonebook (with only two entries).

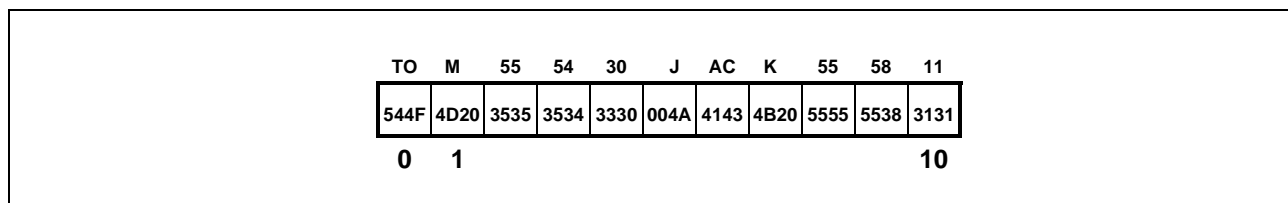

Figure 38 Binary File Organization - Example

There is one special file in the voice prompt directory (referenced by file number 255) which is intended for a large number of phrases and hence has a different organization. This file exists only in the directory for the voice prompt memory. It consists of up to 2048 phrases of arbitrary individual length. The actual number of units within an individual phrase is determined during creation and cannot be altered afterwards. Phrases can be combined in any sequence without intermediate noise or gaps.

Functional Description

Figure 39 shows a phrase file containing a total of five phrases.

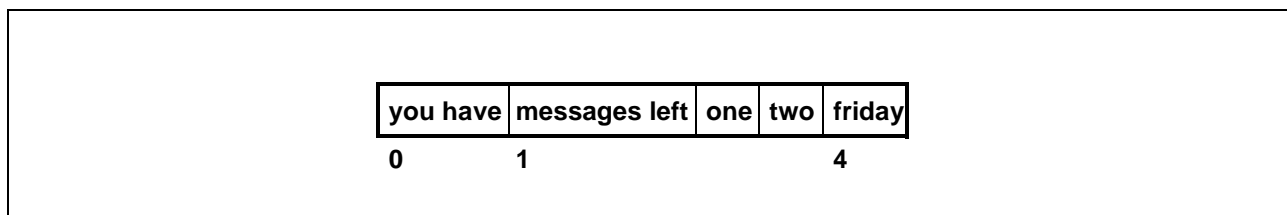

Figure 39 Phrase File Organization - Example

Before an access to a file can take place, the file must be opened with the following information:

1. memory space
2. file number
3. access mode

These parameters remain effective until the next open command is given or, in case of the file pointer, until a file access. All other files are closed and cannot be accessed. The file with file number 0 is not a physical file. Opening this file closes all physical files.

The PSB 4860 provides four registers for file access and two bits within the STATUS register. Table 33 shows these registers.

Table 33 Memory Management Registers

Register	# of Bits	Comment
FCMD	16	Command to execute
FCTL	16	Access mode and file number
FDATA	16	Data transfer and additional parameters
FPTR	16 (11)	File pointer (phrase selector)
STATUS	16	Busy and Error indication

The status register contains two flags (table 34) to indicate if currently a file command is under execution and if the last file command terminated without error. A new command must not be written to FCMD while the last one is still running (STATUS:BSY=1). The only command that can be aborted is Compress File.

Table 34 Memory Management Status

Register	# of Bits	Name	Comment
STATUS	1	BSY	File command or decoder/encoder still running
STATUS	1	ERR	File command completed/aborted with error

Functional Description

Writing to FCMD also resets the error bit in the status register.

Table 35 shows the parameters defining the access mode and the access location. All parameters can only be written when no file command is currently running. They become effective after the completion of an open command. If another unit (e.g. speech coder) accesses the file, the file pointer is updated automatically. Therefore the controller can monitor the progress of recording or playing by reading the file pointer.

Table 35 Memory Management Parameters

Register	# of Bits	Name	Comment
FCTL	1	MS	Memory space (R/W or voice prompt)
FCTL	1	MD	Access mode (audio or binary)
FCTL	1	TS	Write timestamp (file open only)
FCTL	8	FNO	File number (active file)
FPTR	16		File pointer or phrase selector

Commands are written to the FCMD register. The busy bit in the STATUS register is set within 125µs. The command may start execution after a delay, however (see section 2.2.5). Some commands require additional parameters which are written prior to the command into the specified registers. Data transfer is done by the register FDATA (both reading and writing).

2.2.2 User Data Word

The user data word consists of 12 bits that can be read or written by the user, two bits (R) that are reserved for future use and two read-only bits (D,M) which indicate the status of a file.

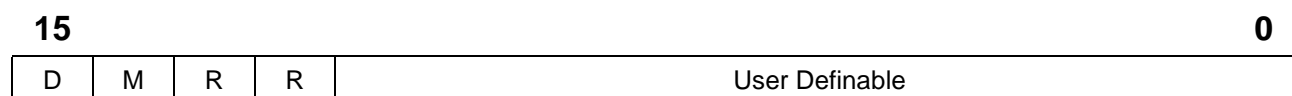

If D is set, the file is marked for deletion and should not be used any more. This bit is maintained by the PSB 4860 for housekeeping.

Functional Description

2.2.3 High Level Memory Management Commands

This section describes each of the high level memory management commands in detail. These commands are sufficient for normal operation of an answering machine. In addition, there are four low level commands (section 2.2.4). These commands are only required for special tasks like in-system reprogramming of the voice prompt area.

2.2.3.1 Initialize

This command creates a directory, sets the external memory configuration and delivers the size of usable memory in 1 kByte blocks. Furthermore the voice prompt memory space is scanned for a valid directory. The PSB 4860 can either create an empty directory from scratch or leave the first n files of an existing directory untouched while deleting the remaining files (ARAM/DRAM only). This option is useful if due to an unexpected event (e.g. power loss during recording) some data is corrupted. In that case vital system information can still be recovered if it has been stored in the first files.

Table 36 Initialize Memory Parameters

Register	# of Bits	Name	Comment
FCMD	5	CMD	Initialize command code
FCMD	1	IN	Confirmation for Initialization
FCTL	8	FNO	0: delete no file 1: delete all files n: delete starting with file n
CCTL	2	MT	Type of R/W memory (DRAM, Flash)
CCTL	1	MQ	Quality of R/W memory (Audio, Normal)
CCTL	1	MV	Scan for voice prompt directory

Table 37 Initialize Memory Results

Register	# of Bits	Name	Comment
FDATA	16		Number of usable 1kByte blocks in R/W memory

Possible Errors:

- no R/W memory found
- more than 59 bad blocks (flash and ARAM)
- voice prompt directory requested, but not detected

Note: This command must be given only once for flash devices.

Functional Description

2.2.3.2 Activate

This command activates an existing directory, sets the external memory configuration and delivers the size of usable memory in 1 kByte blocks. Furthermore the voice prompt memory space is scanned for a valid directory. Upon activation the PSB 4860 checks (in case of ARAM/DRAM only) the consistency of the directory in R/W memory space. It returns the first file that contains corrupted data (if any). If corrupted data is detected an initialization should be performed with the same file number as an input parameter.

Table 38 Activate Memory Parameters

Register	# of Bits	Name	Comment
FCMD	5	CMD	Activate command code
CCTL	2	MT	Type of R/W memory (DRAM, Flash)
CCTL	1	MQ	Quality of R/W memory (Audio, Normal)
CCTL	1	MV	Voice prompt directory available

Table 39 Activate Memory Results

Register	# of Bits	Name	Comment
FDATA	16		Number of usable 1 kByte blocks in R/W memory
FCTL	8	FNO	n: number of first corrupted file

Possible error conditions:

- no memory connected
- no directory found
- device ID wrong (flash only)
- corrupted files found (see FCTL:FNO)
- directory corrupted

This command can have three types of result as shown in table 40.

Table 40 Activate Memory Result Interpretation

Result	STATUS: ERR	FCTL: FNO	Comment
no error	0	0	Command successful, memory activated.
soft error	1	n	The first n-1 files are O.K. The memory is activated.
hard error	1	1	The memory is not activated due to a hard error.

Functional Description

2.2.3.3 Open File

A specific file is opened for subsequent accesses with the specified access mode. Opening a new file automatically closes the currently open file and clears the file pointer. Opening file number 0 can be used to close all physical files. If the TS flag is set, the current content of RTC1 and RTC2 is written to the appropriate fields of the file descriptor in order to provide a timestamp.

Table 41 Open File Parameters

Register	# of Bits	Name	Comment
FCMD	5	CMD	Open command code
FCTL	1	MS	Memory space (R/W, voice prompt)
FCTL	1	MD	Access mode (audio or binary)
FCTL	1	TS	Write timestamp
FCTL	8	FNO	File number <fno>

Possible error conditions:

- selected file marked for deletion, but not yet deleted by garbage collection
- memory space invalid
- new file selected, but memory full
- <fno> exceeds number of prompts (in voice prompt space only)
- wrong access mode selected for existing file

Note: In case of flash memory existing ones in the entries RTC1/RTC2 of the file descriptor cannot be altered. Therefore TS should be set only once during the lifetime of a file.

2.2.3.4 Open Next Free File

The next free file is opened for subsequent write accesses with the specified access mode. The search starts at the specified file number. If the TS flag is set, the current content of RTC1 and RTC2 is written to the appropriate fields of the file descriptor in order to provide a timestamp. If a free file has been found, the file is opened and the file number is returned in FCTL:FNO. Otherwise an error is reported.

Table 42 Open Next Free File Parameters

Register	# of Bits	Name	Comment
FCMD	5	CMD	Open Next Free File command code
FCTL	1	MD	Access mode (audio or binary)

Functional Description

Table 42 Open Next Free File Parameters

Register	# of Bits	Name	Comment
FCTL	1	TS	Write timestamp
FCTL	8	FNO	Starting point (>0)

Table 43 Open Next Free File Results

Register	# of Bits	Name	Comment
FCTL	8	FNO	File number

Possible error conditions:

- no unused file found
- memory full

Note: In case of flash memory existing ones cannot be altered. Therefore TS should be set only once during the lifetime of a file.

Note: R/W-memory must be selected. Otherwise the result is unpredictable.

2.2.3.5 Seek

The file pointer of the currently opened file is set to the specified position. If the current file is the phrase file the PSB 4860 starts the speech decoder immediately after the seek is finished. This is done by simply enabling the decoder. All other settings of the decoder remain unaffected. The BSY bit is first set during the file command. It is then reset for a short period until the speech decoder is enabled internally. It is then set again while the decoder is running and finally reset when the phrase is finished.

Table 44 Seek Parameters

Register	# of Bits	Name	Comment
FCMD	5	CMD	Seek command code
FPTR	16 (11)		File pointer (phrase selector)

Possible error conditions:

- file pointer out of range
- phrase number out of range

Functional Description

2.2.3.6 Cut File

All units starting with the unit addressed by the file pointer are removed from the file. If all units are deleted the file is marked for deletion (see user data word). However, the associated file descriptor and memory space are released only after a subsequent garbage collection.

Table 45 Cut File Parameters

Register	# of Bits	Name	Comment
FCMD	5	CMD	Cut command code
FPTR	16		Position of first unit to delete

Possible error conditions:

- file pointer out of range
- voice prompt memory selected

2.2.3.7 Compress File

An audio file that has been recorded in HQ mode can be recoded using LP mode. This reduces the file size to approximately one third of the original size. The speech quality, however, is somewhat lower compared to a signal that has been recorded in LP mode in the first place. This command can be aborted at any time and resumed later without loss of information. Prior to this command all files must be closed. Table 46 shows the parameters for this command.

Table 46 Compress File Parameters

Register	# of Bits	Name	Comment
FCMD	5	CMD	Compress command code
FCTL	8	FNO	File number <fno>

Possible error conditions:

- <fno> invalid
- another file currently open
- binary file selected

Functional Description

2.2.3.8 Memory Status

This command returns the number of available 1 kB blocks in R/W memory space.

Table 47 Memory Status Parameters

Register	# of Bits	Name	Comment
FCMD	5	CMD	Memory status code

Table 48 Memory Status Results

Register	# of Bits	Name	Comment
FDATA	16	FREE	Number of free blocks

Possible error conditions:

- file open

2.2.3.9 Garbage Collection

This command initiates a garbage collection. Until a garbage collection files that are marked for deletion still occupy the associated file descriptor and memory space. After the garbage collection these file descriptors and the associated memory space are available again. This command can optionally remap the directory. In this mode the remaining file descriptors are remapped to form a contiguous block starting with file number 1. The original order is preserved. This command requires that all files are closed, i.e. file 0 is opened. Independently of the selected directory only the read/write directory is used.

Table 49 Garbage Collection Parameters

Register	# of Bits	Name	Comment
FCMD	5	CMD	Garbage Collection Command Code
FCMD	1	RD	Remap Directory

Possible error conditions:

- file open

2.2.3.10 Access File Descriptor

By this command the length, user data word and RTC1/RTC2 of a file descriptor can be read. The user data word can also be written. The file or the other entries of the file descriptor are not affected by this command.

Functional Description

Table 50 Access File Descriptor Parameters

Register	# of Bits	Name	Comment
FCMD	5	CMD	Read Access or Write Access command code
FDATA	16		User data (write access only)

Table 51 Access File Descriptor Results

Register	# of Bits	Name	Comment
FDATA	16		Content of selected entry (read access only)

Possible error conditions:

- none

Note: In case of flash memory bits already set to 1 cannot be altered.

Note: Do not use this command with the phrase file (fno = 255).

2.2.3.11 Read Data

This command can be used in binary access mode only. A single word is read at the position given by the file pointer. The file pointer can be set by the Seek command. The file pointer is advanced by one word automatically.

Table 52 Read Data Parameters

Register	# of Bits	Name	Comment
FCMD	5	CMD	Read Data Command Code

Table 53 Read Data Results

Register	# of Bits	Name	Comment
FDATA	16		Data word

Possible error conditions:

- file pointer out of range
- phrase file selected
- audio file selected

Functional Description

2.2.3.12 Write Data

This commands can be used in binary access mode only. A single word is written at the position of the file pointer. The file pointer is advanced by one word automatically. Note, that for FLASH memory only zeroes can be overwritten by ones. This restriction occurs only if an already used value within an existing file is to be overwritten.

Table 54 Write Data Parameters

Register	# of Bits	Name	Comment
FCMD	5	CMD	Access Mode Command Code (including mode)
FDATA	16		Data word

Possible error conditions:

- file pointer out of range (for existing files only)
- voice prompt memory selected
- memory full
- audio file selected

Functional Description

2.2.4 Low Level Memory Management Commands

These commands allow the direct access of any location (single word) of the external memory. Additionally it is possible to erase any block in case of a flash device. These commands should not be used during normal operation as they may interfere with the file system. No file must be open when one of these commands is given.

The primary use of these commands is the in-system programming of a flash device with voice prompts. Please refer to the appropriate Application Notes.

2.2.4.1 Set Address

This command sets the 24 bit address pointer APTR. Only the address bits A₈-A₂₃ are set, the address bits A₀-A₇ are automatically cleared.

Table 55 Set Address Parameters

Register	# of Bits	Name	Comment
FCMD	5	CMD	Set Address command code
FDATA	16	ADR	Address bits A ₈ -A ₂₃ of address pointer APTR

Possible error conditions:

- file open

2.2.4.2 DMA Read

This command reads a single word addressed by APTR. After the read access APTR is automatically incremented by one. Table 56 shows the parameters for this command.

Table 56 DMA Read Parameters

Register	# of Bits	Name	Comment
FCMD	5	CMD	DMA Read command code

Table 57 DMA Read Results

Register	# of Bits	Name	Comment
FDATA	16	DATA	Data read from address APTR.

Possible error conditions:

- file open

Functional Description

2.2.4.3 DMA Write

This command writes a single word to the location addressed by APTR. After the write access APTR is automatically incremented by one. Table 58 shows the parameters for this command.

Table 58 DMA Write Parameters

Register	# of Bits	Name	Comment
FCMD	5	CMD	DMA Write command code
FDATA	16	DATA	Data to be written to APTR

Possible error conditions:

- file open

Note: If flash memory is connected the actual write is only performed when the last word within a page is written. Until then the data is merely buffered in the flash device. Please check the flash memory data sheets on page size.

2.2.4.4 Block Erase

This command erases the physical block which includes the address given by APTR. The actual amount of memory erased by this command depends on the block size of the flash device. Table 59 shows the parameters for this command.

Table 59 Block Erase Parameters

Register	# of Bits	Name	Comment
FCMD	5	CMD	Block Erase command code

Possible error conditions:

- file open
- ARAM/DRAM configured

2.2.5 Execution Time

The execution time of the file commands is determined by four factors:

1. Internal state of the PSB 4860
2. Memory configuration
3. Memory state
4. Individual characteristics of the memory devices

Therefore there is no general formula for an exact calculation of the execution time for file commands. For ARAM/DRAM items three and four are not significant as the memory access timing is always fixed and no additional delay is incurred for erasing memory blocks. However, the amount of memory has significant impact on the initialization in case of ARAM and flash.

For flash devices the particular location of a write access in combination with the internal organization of the memory device may result in a block erase and subsequent write accesses in order to copy data. In this case the individual erase and write timing of the attached devices also prolongs the execution time.

The first factor, the internal state of the PSB 4860, can influence all file commands regardless of the memory type attached. In general the PSB 4860 may delay any file command by up to 30 ms. However, it is possible to skip this delay if the following conditions hold:

1. The command is not *initialize/activate*
2. Neither the DTMF detector nor the speech coder nor the speech decoder are running

If neither condition is violated then the PSB 4860 can be forced to start command execution immediately. This is done by setting the EIE bit in the FCMD register along with the command code.

Table 60 gives an indication of the execution time for two typical memory configurations.

Table 60 Execution Times

Command	ARAM (4 MBit)	KM29LV040
Initialize	40 s ¹⁾	<11 s
Activate	< 10 ms	3 s
Open File /Open Next Free File	<10 ms	<26 ms
Seek (within 4 MBit File)	<0.5 s	<0.5 s
Seek (within phrase file)	<1 ms	<1 ms
Cut File	<5 ms	<5 ms
Compress File	#units * 30 ms	#units * 30 ms
Access File Descriptor	<10 ms	<10 ms

Functional Description

Table 60 Execution Times

Command	ARAM (4 MBit)	KM29LV040
Memory Status	<10 ms	<10 ms
Read/Write Data	<10 ms	<10 ms
Garbage Collection	<20 ms	3 s

¹⁾ less than 20 ms for DRAM

2.2.6 Special Notes on File Commands

1. No MMU commands must be inserted between opening a file and writing data to it, either by writing data to a binary file or by enabling the coder for audio files. Therefore reading or writing the file descriptor is only allowed after all data writing has happened.
2. If an audio file has been opened for replay, a Write File Descriptor Command must be followed by a Seek command before the decoder can be enabled.

Functional Description

2.3 Miscellaneous**2.3.1 Real Time Clock**

The PSB 4860 supplies a real time clock which maintains time with a resolution of a second and a range of up to a year. There are two registers which contain the current time and date (table 61).

Table 61 Real Time Clock Registers

Register	# of Bits	Name	Comment
RTC1	6	SEC	Seconds elapsed
RTC1	6	MIN	Minutes elapsed
RTC2	5	HR	Hours elapsed
RTC2	11	DAY	Days elapsed

The real time clock maintains time during normal mode and power down mode only if the auxiliary oscillator OSC is running and the RTC is enabled.

Note: Writing out-of-range values to RTC1 and RTC2 results in undefined operation of the RTC

2.3.2 SPS Control Register

The two SPS outputs (SPS₀, SPS₁) can be used as either general purpose outputs, speakerphone status outputs, extended address outputs for Voice Prompt EPROM or as status register outputs. Table 62 shows the associated register.

Table 62 SPS Registers

SPSCTL	1	SP0	Output Value of SPS ₀
SPSCTL	1	SP1	Output Value of SPS ₁
SPSCTL	3	MODE	Mode of Operation
SPSCTL	4	POS	Position for status register window

When used as status register outputs, the status register bit at position POS appears at SPS₀ and the bit at position POS+1 appears at SPS₁. This mode of operation can be used for debugging purposes or direct polling of status register bits.

2.3.3 Reset and Power Down Mode

The PSB 4860 can be in either reset mode, power down mode or active mode. During reset the PSB 4860 clears the hardware configuration registers and stops both internal

Functional Description

and external activity. The address lines MA₀-MA₁₅ provide a weak low until they are actually used as address lines (strong outputs) or auxiliary port pins (I/O). In reset mode the hardware configuration registers can be read and written. With the first access to a read/write register the PSB 4860 enters active mode. In this mode the main oscillator is running and normal operation takes place. By setting the power down bit (PD) the PSB 4860 can be brought to power down mode.

Table 63 Power Down Bit

Register	# of Bits	Name	Comment
CCTL	1	PD	power down mode

In power down mode the main oscillator is stopped and, depending on HWCONFIG2:PPM), the memory control lines are released (weak high). Depending on the configuration (ARAM/DRAM, APP) the PSB 4860 may still generate external activity (e.g. refresh cycles). The PSB 4860 enters active mode again upon an access to a read/write register. Figure 40 shows a state chart of the modes of the PSB 4860.

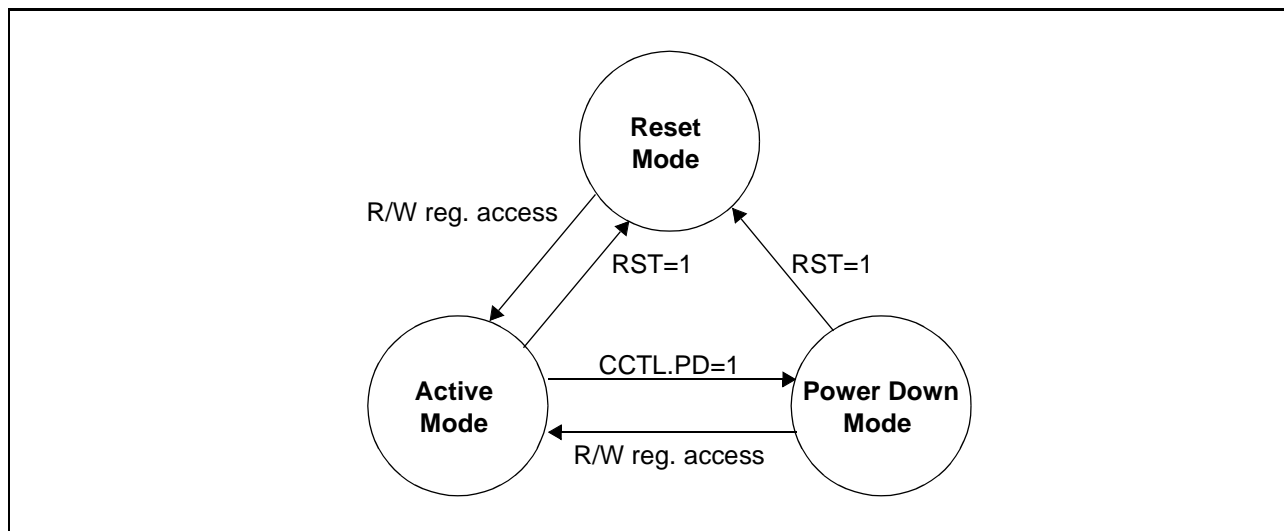

Figure 40 Operation Modes - State Chart

2.3.4 Interrupt

The PSB 4860 can generate an interrupt to inform the host of an update of the STATUS register according to table 64. An interrupt mask register (INTM) can be used to disable or enable the interrupting capability of each bit of the STATUS register except ABT individually.

Functional Description

Table 64 Interrupt Source Summary

STATUS (old)	STATUS (new)	Set by	Reset by
RDY=0	RDY=1	Command completed	Command issued
CIA=0	CIA=1	New Caller ID byte available	CIDCTL0 read
CD=0	CD=1	Carrier detected	Carrier lost
CD=1	CD=0	Carrier lost	Carrier detected
CPT=0	CPT=1	Call progress tone detected	CPT lost
CPT=1	CPT=0	Call progress tone lost	CPT detected
CNG=0	CNG=1	Fax calling tone detected	CNG lost
DTV=0	DTV=1	DTMF tone detected	DTMF tone lost
DTV=1	DTV=0	DTMF tone lost	DTMF tone detected
ATV=0	ATV=1	Alert tone detected	Alert tone lost
ATV=1	ATV=0	Alert tone lost	Alert tone detected
BSY=1	BSY=0	File command completed	New command issued
SD=0	SD=1	Speech activity detected	Speech activity lost
SD=1	SD=0	Speech activity lost	Speech activity detected

An interrupt is internally generated if any combination of these events occurs and the interrupt is not masked. The interrupt is cleared when the host reads the STATUS register. If a new event occurs while the host reads the status register, the status register is updated *after* the current access is terminated and a new interrupt is generated immediately after the access has ended.

Note: If the internal interrupt occurs after the controller has already selected the device but not yet read the STATUS word, then the STATUS word is updated and the internal interrupt is cleared. Therefore the controller should always evaluate the STATUS word when read.

2.3.5 Abort

If the PSB 4860 cannot continue the current operations in progress (e.g. due to a transient loss of power) it stops operation and initializes all read/write registers to their reset state. After that it sets the ABT bit of the STATUS register and generates an interrupt. The PSB 4860 discards all commands with the exception of a write command to the revision register while ABT is set. Only after the write command to the revision register (with any value) the ABT bit is reset and a reinitialization can take place.

Functional Description

2.3.6 Revision Register

The PSB 4860 contains a revision register. This register is read only and does not influence operation in any way. A write to the revision register clears the ABT bit of the STATUS register but does not alter the content of the revision register.

2.3.7 Hardware Configuration

The PSB 4860 can be adapted to various external hardware configurations by four special registers: HWCONFIG0 to HWCONFIG3. These registers are usually only written once during initialization and must not be changed while the PSB 4860 is in active mode. It is mandatory that the programmed configuration reflects the external hardware for proper operation. Special care must be taken to avoid I/O conflicts or excess current by enabling inputs without an external driving source. Table 65 can be used as a checklist.

Table 65 Hardware Configuration Checklist

Register	Name	Value	Check
HWCONFIG0	PFRDY	1	FRDY must not float
HWCONFIG0	OSC	1	OSC1/2 must be connected to a crystal
HWCONFIG0	ACS	1	CLK must not float (tie low if no clock present)
HWCONFIG1	MFS	1	FSC must not float (tie low if no clock present)
HWCONFIG1	ACT	1	FSC must not float (tie low if no clock present)

2.3.8 Frame Synchronization

The PSB 4860 locks itself to either an externally supplied clock or frame sync signal or generates the frame sync signal itself. This internal reference frame sync signal is called master frame sync (MFSC). In addition, the PSB 4860 can derive the AFECLK and AFEFSC from either the main oscillator or an auxiliary clock input. Table 66 shows how AFECLK and MFSC are derived by the PSB 4860. The bits ACS and MFS are contained in the hardware configuration registers.

Table 66 Frame Synchronization Selection

ACS	MFS	AFECLK	MFSC	Application
0	0	XTAL	AFEFSC	Analog featurephone
0	1	-	FSC	ISDN stand-alone
1	0	CLK	AFEFSC	DECT
1	1	CLK	FSC	unused

Functional Description

2.3.9 Clock Tracking

The PSB 4860 can adjust AFECLK and AFEFSC dynamically to a slightly varying FSC if AFECLK and AFEFSC are derived from the main oscillator (XTAL). This mode requires that both AFEFSC and FSC are nominally running at the same frequency (8 kHz).

This feature is especially useful when the FSC signal is not derived from the same clock source as AFECLK (ISDN application).

2.3.10 Dependencies of Modules

There are some restrictions concerning the modules that can be enabled at the same time (table 67). A checked cell indicates that the two modules (defined by the row and the column of the cell) must not be enabled at the same time.

Table 67 Dependencies of Modules

	Speech Encoder	Speech Decoder	Line EC (24 ms)	Acoustic EC	DTMF Detector	File Command
Speech Enc.		X	X	X		B,O,I
Speech Dec.	X		X ¹⁾	X		B,O,I
Line EC (24 ms)	X	X ¹⁾		X		B,O
Acoustic EC	X	X	X		X	B,O
DTMF Det.				X		B,I
File Cmd.	B,O,I	B,O,I	B,O	B,O	B,I	

¹⁾ if Speech Decoder is running at slow speed

There are three classes of file commands denoted by the letters B, O and I. Table 68 shows the definition of these classes:

Table 68 File Command Classes

Class	Description
B	Background commands (Activate, Recompress, Garbage Collection, Initialize)
O	Open Commands (Open, Open Next Free File)
I	Any command executed with EIE=1 (i.e. immediate execution)

Examples:

- The line echo canceller (in 24 ms mode) cannot be enabled when the speech decoder is running at slow speed.
- If the DTMF detector is running, none of the background file commands (B) must be executed. In addition, no file command must be executed with immediate execution

Functional Description

enabled (I). However, files may be opened and other commands (like read or write) may be executed without immediate execution enabled.

Furthermore it may be necessary to restrict the length of the FIR filter of the echo cancellation unit if several other units are operating at the same time. The sum of all weights (table 69) of the simultaneously enabled modules must not exceed 100 at any given time.

Table 69 Module Weights

Module	Weight	Comment	Example 1	Example 2
Equalizer	2.8		X	X
CPT Detector	5.6			
Caller ID Decoder ¹⁾	4.2		X	
CNG Detector	2.6			
DTMF Generator	2.2		X	
Echo Cancellation	52.1	127 taps (16 ms)		
Echo Cancellation	62.5	255 taps (32 ms)	X	
Echo Cancellation	72.9	383 taps (48 ms)		
Echo Cancellation	83.3	511 taps (64 ms)		X
Line Echo Cancellation	12.7		X	
Universal Attenuator	0.2			
Digital Interface	1.7	channel 1 or SSDI		X
Digital Interface	1.7	channel 2		
Analog Interface	2.5		X	X
Clock Tracking	0.6			X
Miscellaneous	8.0	always active	X	X

¹⁾ The alert tone detector would add another 2.6, but can be disabled after the alert tone has been detected. Therefore it can be left out of the calculation.

Example:

- For an analog phone echo cancellation, DTMF tone generation, caller ID reception, and line echo cancellation are necessary. The system uses the PSB 4851 and the equalizer to linearize the loudspeaker. In this case the sum of all weights without echo cancellation is 35.6. Therefore 255 taps can be used for a total of 98.1.
- In an ISDN phone echo cancellation, channel 1 of the digital interface, the analog interface with clock tracking and the equalizer shall be enabled at the same time. In

Functional Description

this application the sum of all weights without echo cancellation is 15.6. Therefore 511 taps can be used for a total of 98.9.

Functional Description

2.4 Interfaces

This section describes the interfaces of the PSB 4860. The PSB 4860 supports both an IOM[®]-2 interface with single and double clock mode and a strobed serial data interface (SSDI). However, these two interfaces cannot be used simultaneously as they share some pins. Both interfaces are for data transfer only and cannot be used for programming the PSB 4860. Table 70 lists the features of the two alternative interfaces.

Table 70 SSDI vs. IOM[®]-2 Interface

	IOM [®] -2	SSDI
Signals	4	6
Channels (bidirectional)	2	1
Code	linear PCM, A-law, μ -law	linear PCM
Synchronization within frame	by timeslot (programmable)	by signal (DXST, DRST)

2.4.1 IOM[®]-2 Interface

The data stream is partitioned into packets called frames. Each frame is divided into a fixed number of timeslots. Each timeslot is used to transfer 8 bits. Figure 41 shows a commonly used terminal mode (three channels ch_0 , ch_1 and ch_2 with four timeslots each). The first timeslot (in figure 41: B1) is denoted by number 0, the second one (B2) by 1 and so on.

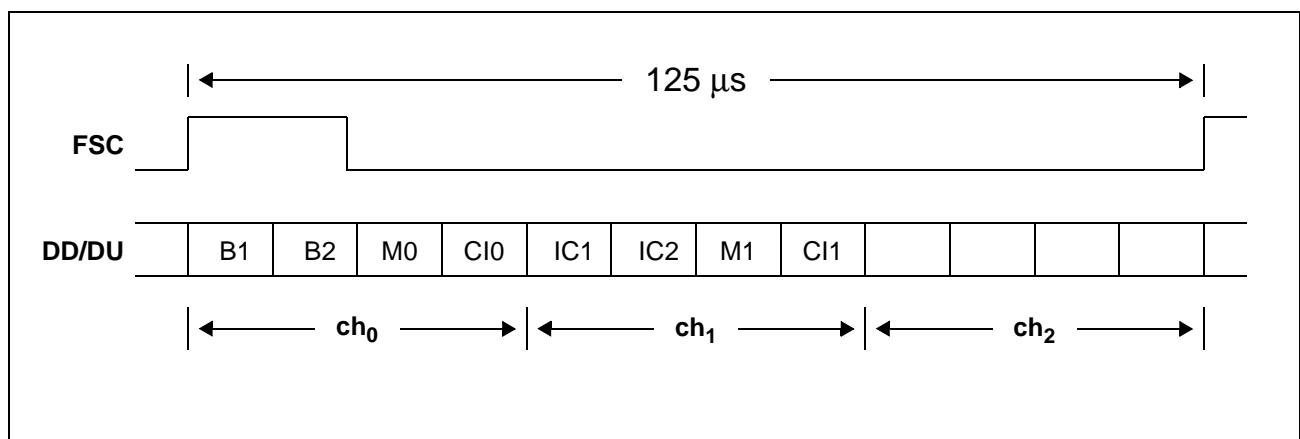

Figure 41 IOM[®]-2 Interface - Frame Structure

The signal FSC is used to indicate the start of a frame. Figure 42 shows as an example two valid FSC-signals (FSC, FSC*) which both indicate the same clock cycle as the first clock cycle of a new frame (T_1).

Note: Any timeslot (including M0, CI0, ...) can be used for data transfer. However, programming is not supported via the monitor channels.

Functional Description

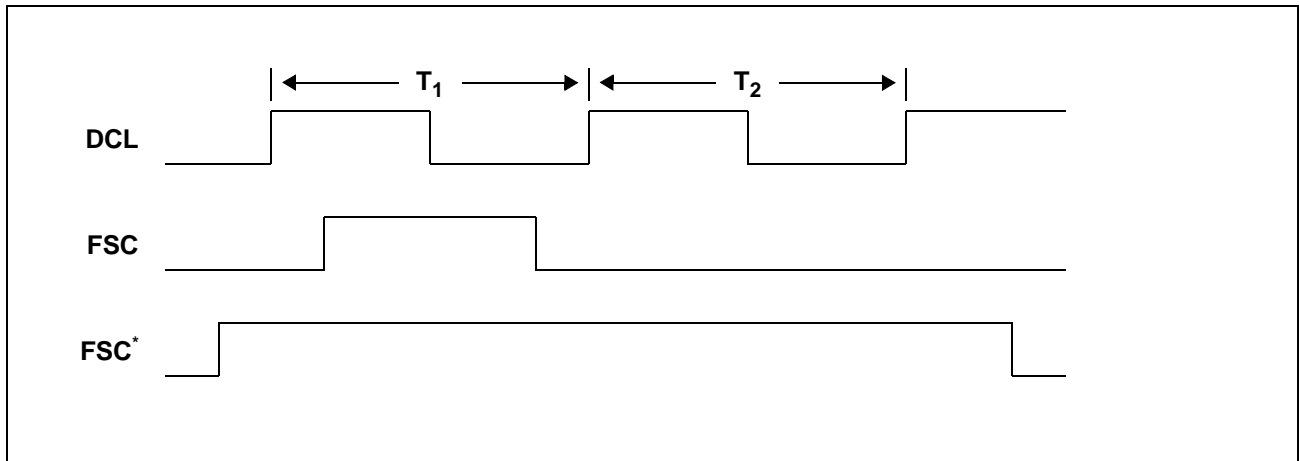

Figure 42 IOM[®]-2 Interface - Frame Start

The PSB 4860 supports both single clock mode and double clock mode. In single clock mode, the bit rate is equal to the clock rate. Bits are shifted out with the rising edge of DCL and sampled at the falling edge. In double clock mode, the clock runs at twice the bit rate. Therefore for each bit there are two clock cycles. Bits are shifted out with the rising edge of the first clock cycle and sampled with the falling edge of the second clock cycle. Figure 43 shows the timing for single clock mode and figure 44 shows the timing for double clock mode.

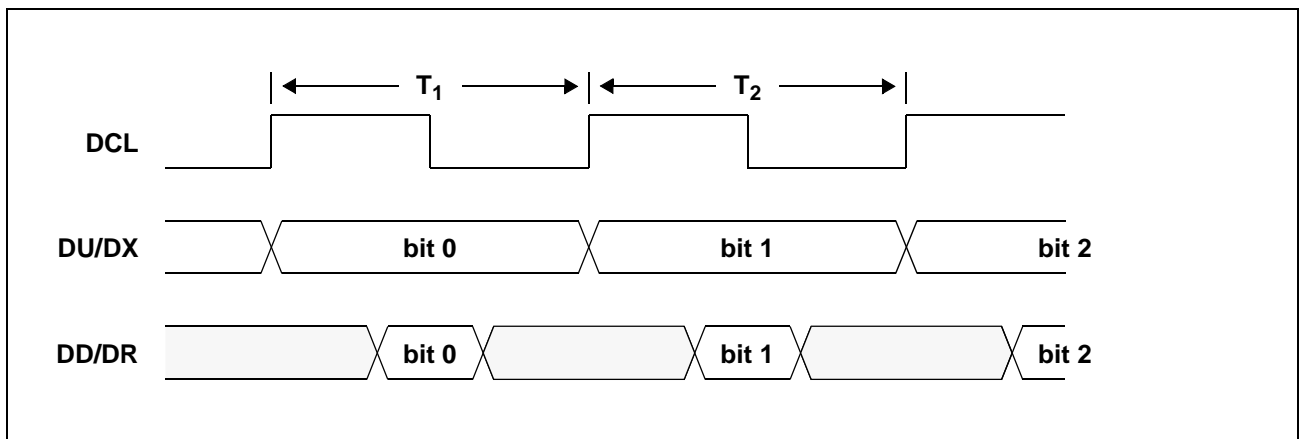

Figure 43 IOM[®]-2 Interface - Single Clock Mode

Functional Description

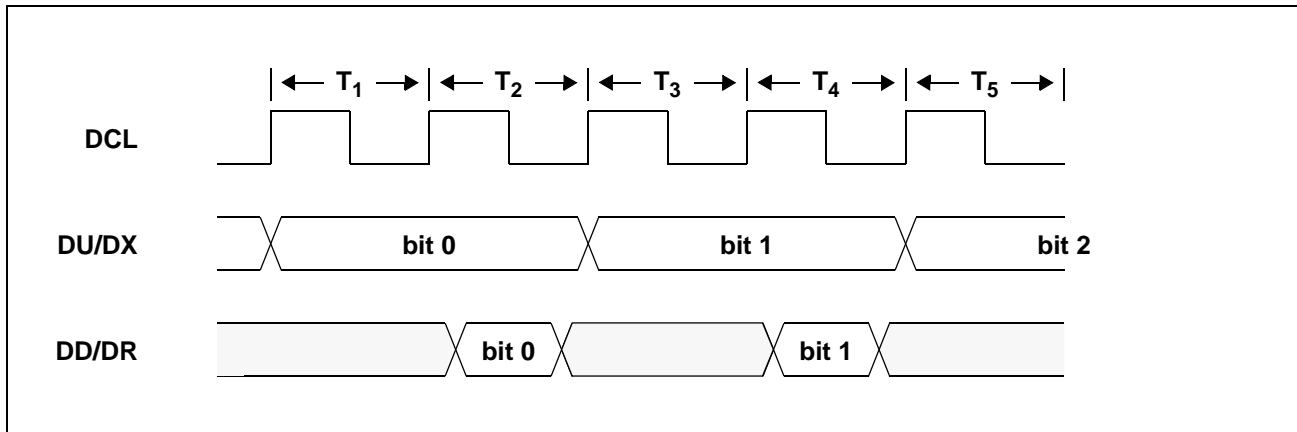

Figure 44 IOM[®]-2 Interface - Double Clock Mode

The PSB 4860 supports up to two channels simultaneously for data transfer. Both the coding (PCM or linear) and the data direction (DD/DU assignment for transmit/receive) can be programmed individually for each channel. Table 71 shows the registers used for configuration of the IOM[®]-2 interface.

Table 71 IOM[®]-2 Interface Registers

Register	# of Bits	Name	Comment
SDCONF	1	EN	Interface enable
SDCONF	1	DCL	Selection of clock mode
SDCONF	6	NTS	Number of timeslots within frame
SDCHN1	1	EN	Channel 1 enable
SDCHN1	6	TS	First timeslot (channel 1)
SDCHN1	1	DD	Data Direction (channel 1)
SDCHN1	1	PCM	8 bit code or 16 bit linear PCM (channel 1)
SDCHN1	1	PCD	8 bit code (A-law or μ -law, channel 1)
SDCHN2	1	EN	Channel 2 enable
SDCHN2	6	TS	First timeslot (channel 2)
SDCHN2	1	DD	Data Direction (channel 2)
SDCHN2	1	PCM	8 bit code or 16 bit linear PCM (channel 2)
SDCHN2	1	PCD	8 bit code (A-law or μ -law, channel 2)

In A-law or μ -law mode, only 8 bits are transferred and therefore only one timeslot is needed for a channel. In linear mode, 16 bits are needed for a single channel. In this mode, two consecutive timeslots are used for data transfer. Bits 8 to 15 are transferred

Functional Description

within the first timeslot and bits 0 to 7 are transferred within the next timeslot. The first timeslot must have an even number. The most significant bit is always transmitted first.

2.4.2 SSDI Interface

The SSDI interface is intended for seamless connection to low-cost burst mode controllers (e.g. PMB 27251) and supports a single channel in each direction. The data stream is partitioned into frames. Within each frame one 16 bit value can be sent and received by the PSB 4860. The start of a frame is indicated by the rising edge of FSC. Data is always sampled at the falling edge of DCL and shifted out with the rising edge of DCL.

The SSDI transmitter and receiver are operating independently of each other except that both use the same FSC and DCL signal.

2.4.2.1 SSDI Interface - Transmitter

The PSB 4860 indicates outgoing data (on signal DX) by activating DXST for 16 clocks. The signal DXST is activated with the same rising edge of DCL that is used to send the first bit (Bit 15) of the data. DXST is deactivated with the first rising edge of DCL after the last bit has been transferred. The PSB 4860 drives the signal DX only when DXST is activated. Figure 45 shows the timing for the transmitter.

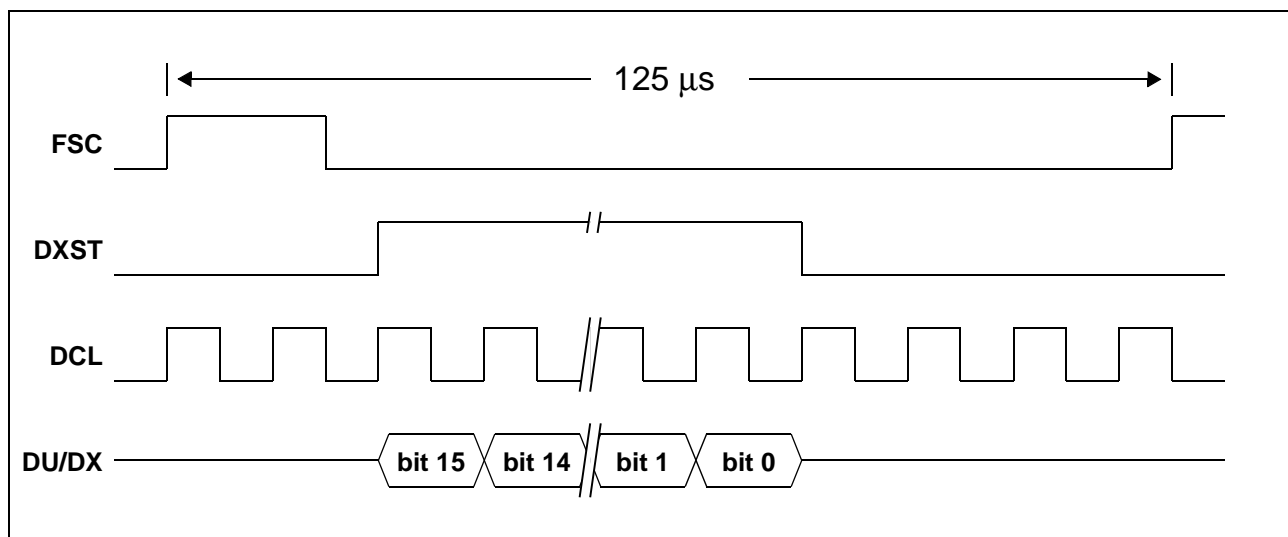

Figure 45 SSDI Interface - Transmitter Timing

2.4.2.2 SSDI Interface - Receiver

Valid data is indicated by an active DRST pulse. Each DRST pulse must last for exactly 16 DCL clocks. As there may be more than one DRST pulses within a single frame the PSB 4860 can be programmed to listen to the n-th pulse with n ranging from 1 to 16. In order to detect the first pulse properly, DRST must not be active at the rising edge of FSC. In figure 46 the PSB 4860 is listening to the third DRST pulse (n=3).

Functional Description

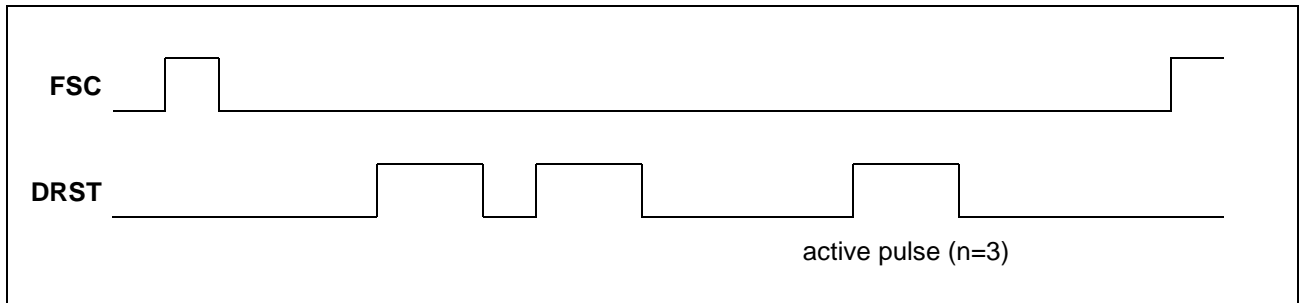

Figure 46 SSDI Interface - Active Pulse Selection

Figure 47 shows the timing for the SSDI receiver.

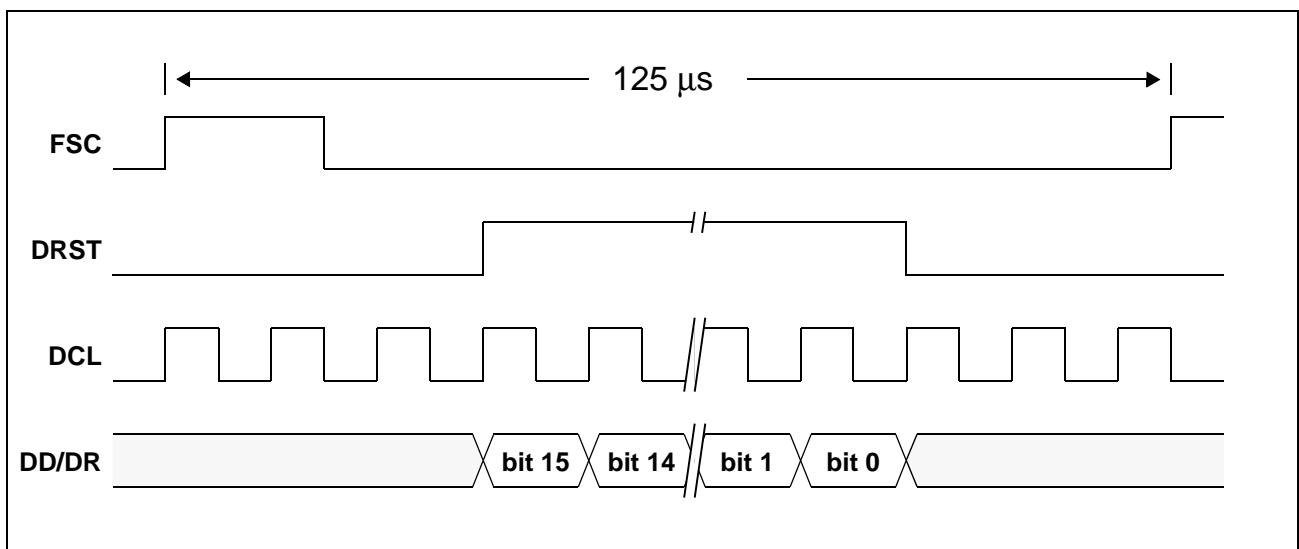

Figure 47 SSDI Interface - Receiver Timing

Table 72 shows the registers used for configuration of the SSDI interface.

Table 72 SSDI Interface Register

Register	# of Bits	Name	Comment
SDCHN1	4	NAS	Number of active DRST strobe

Functional Description

2.4.3 Analog Front End Interface

The PSB 4860 uses a four wire interface similar to the IOM[®]-2 interface to exchange information with the analog front end (PSB 4851). The main difference is that all timeslots and the channel assignments are fixed as shown in figure 48.

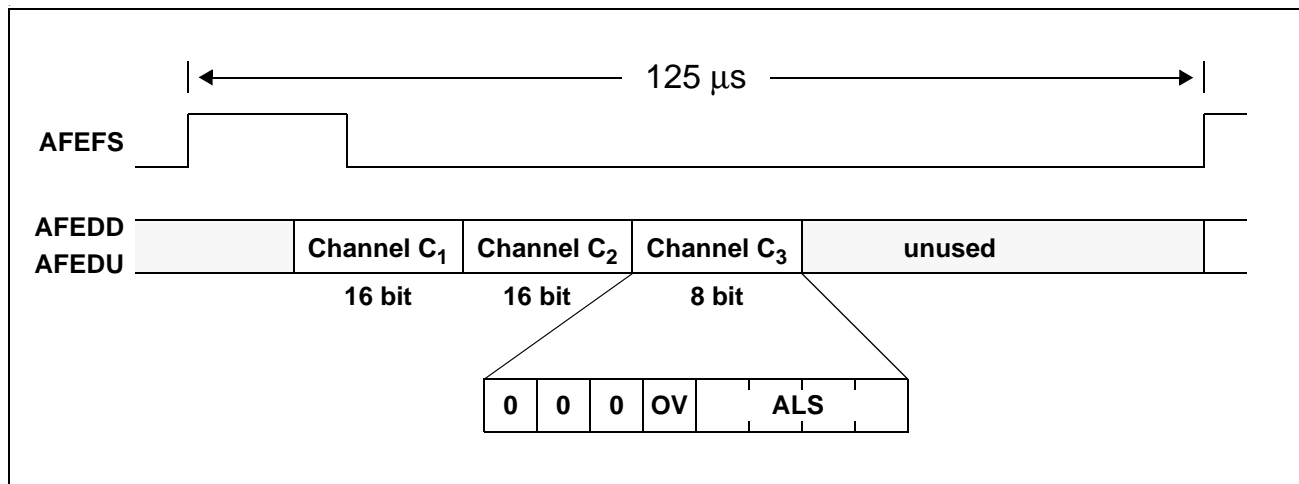

Figure 48 Analog Front End Interface - Frame Structure

Voice data is transferred in 16 bit linear coding in two bidirectional channels C₁ and C₂. An auxiliary channel C₃ is used to transfer the current setting of the loudspeaker amplifier ALS to the PSB 4860. The remaining bits are fixed to zero. In the other direction C₃ transfers an override value for ALS from the PSB 4860 to the PSB 4851. An additional override bit OV determines if the currently transmitted value should override the AOAR:LSC¹⁾ setting. The AOAR:LSC setting is not affected by C₃:ALS override. Table 73 shows the source control of the gain for the ALS amplifier.

Table 73 Control of ALS Amplifier

AOPR:OVRE	C ₃ :OV	Gain of ALS amplifier
0	-	AOAR:LSC
1	0	AOAR:LSC
1	1	C ₃ :ALS

Furthermore the AFE interface can be enabled or disabled according to table 74.

Table 74 Analog Front End Interface Register

Register	# of Bits	Name	Comment
AFECTL	1	EN	Interface enable

¹⁾ See specification of PSB 4851, automatically set by the PSB 4860 in loudhearing mode.

Functional Description

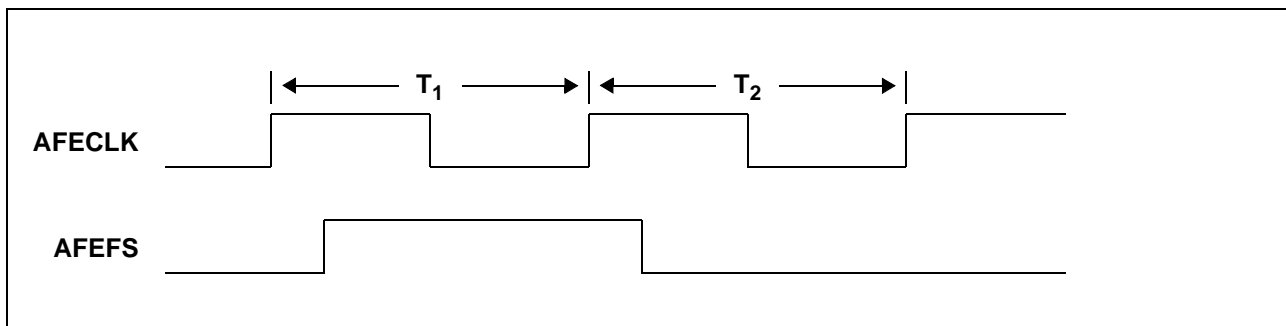

Figure 49 Analog Front End Interface - Frame Start

Figure 49 shows the synchronization of a frame by AFEFS. The first clock of a new frame (T_1) is indicated by AFEFS switching from low to high before the falling edge of T_1 . AFEFS may remain high during subsequent cycles up to T_{32} .

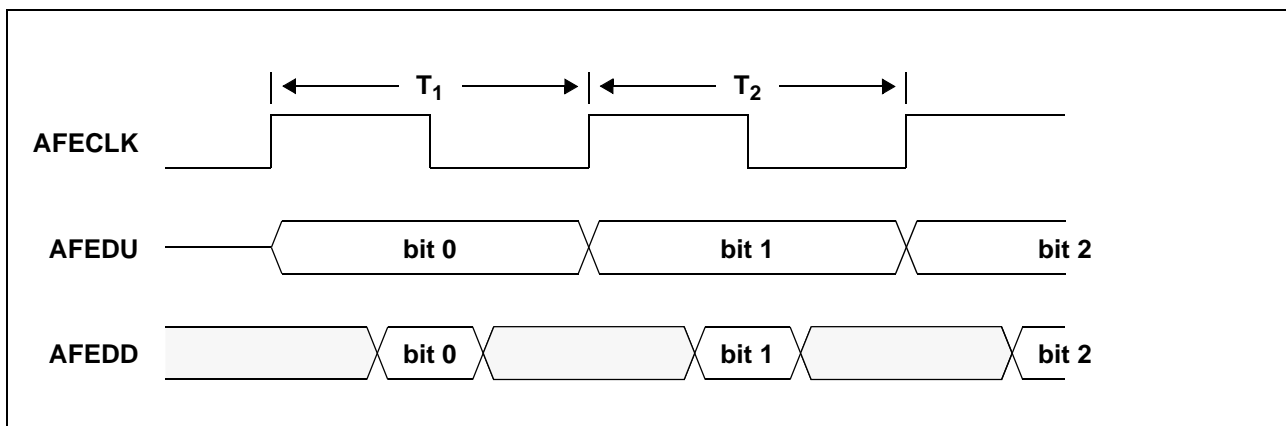

Figure 50 Analog Front End Interface - Data Transfer

The data is shifted out with the rising edge of AFECLK and sampled at the falling edge of AFECLK (figure 50). If AOPR:OVRE is not set, the channel C_3 is not used by the PSB 4851. All values (C_1 , C_2 , C_3 :ALS) are transferred MSB first. The data clock (AFECLK) rate is fixed at 6.912 MHz. Table 75 shows the clock cycles used for the three channels.

Table 75 Analog Front End Interface Clock Cycles

Clock Cycles	AFEDD (driven by PSB 4860)	AFEDU (driven by PSB 4851)
T_1 - T_{16}	C_1 data	C_1 data
T_{17} - T_{32}	C_2 data	C_2 data
T_{33} - T_{40}	C_3 data	C_3 data
T_{41} - T_{864}	0	tristate

2.4.4 Serial Control Interface

The serial control interface (SCI) uses four lines: SDR, SDX, SCLK and \overline{CS} . Data is transferred by the lines SDR and SDX at the rate given by SCLK. The falling edge of \overline{CS} indicates the beginning of an access. Data is sampled by the PSB 4860 at the rising edge of SCLK and shifted out at the falling edge of SCLK. Each access must be terminated by a rising edge of \overline{CS} . The accesses to the PSB 4860 can be divided into three classes:

1. Configuration Read/Write
2. Status/Data Read
3. Register Read/Write

If the PSB 4860 is in power down mode, a read access to the status register does not deliver valid data with the exception of the RDY bit. After the status has been read the access can be either terminated or extended to read data from the PSB 4860. A register read/write access can only be performed when the PSB 4860 is ready. The RDY bit in the status register provides this information.

Any access to the PSB 4860 starts with the transfer of 16 bits to the PSB 4860 over line SDR. This first word specifies the access class, access type (read or write) and, if necessary, the register accessed. If a configuration register is written, the first word also includes the data and the access is terminated. Likewise, if a register read is issued, the access is terminated after the first word. All other accesses continue by the transfer of the status register from the PSB 4860 over line SDX. If a register (excluding configuration) is to be written, the next 16 bits containing the data are transferred over line SDR and the access is terminated. Figures 51 to 54 show the timing diagrams for the different access classes and types to the PSB 4860.

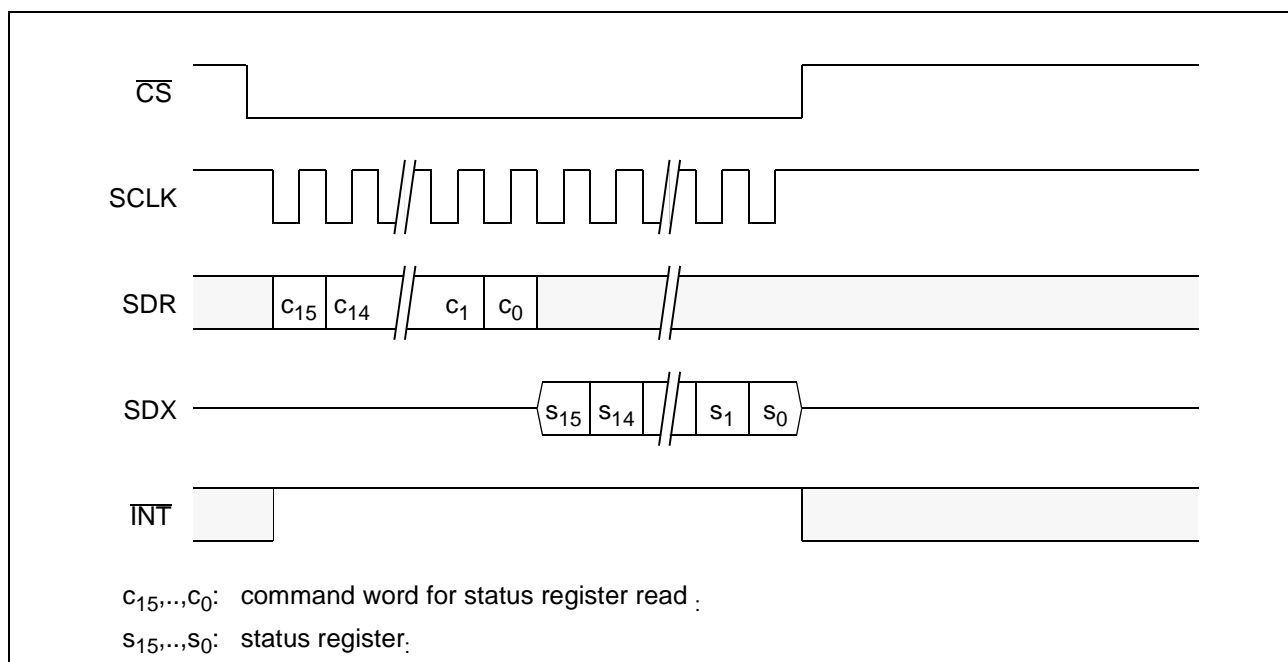

Figure 51 Status Register Read Access

Functional Description

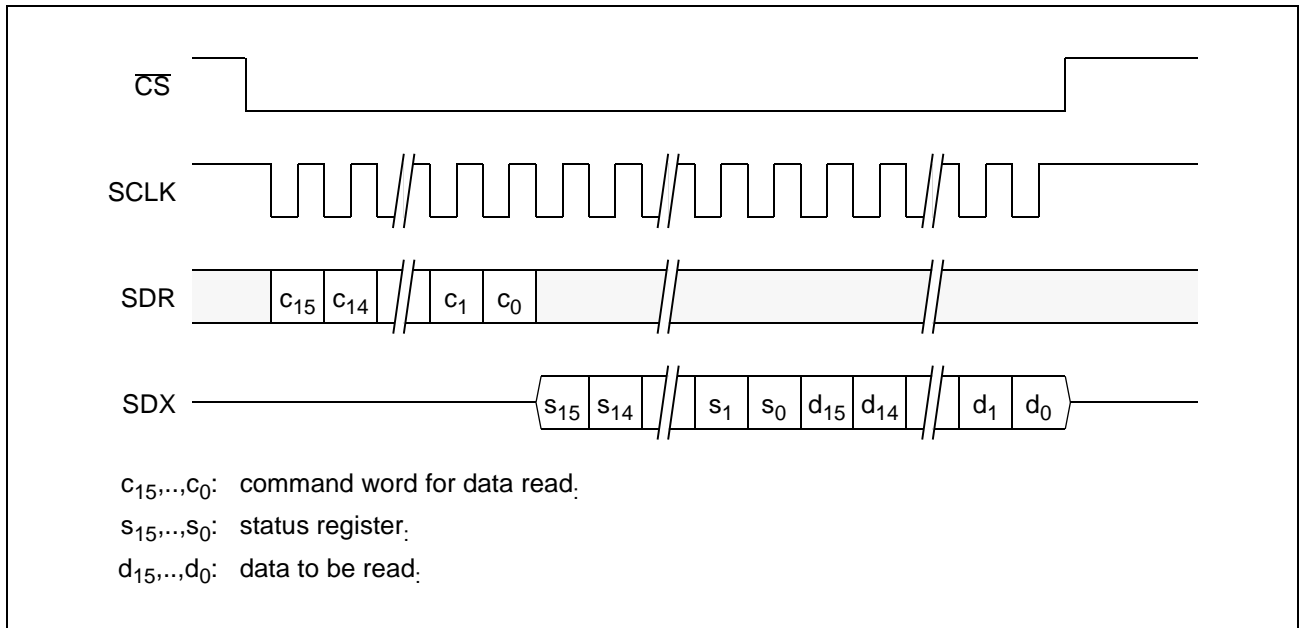

Figure 52 Data Read Access

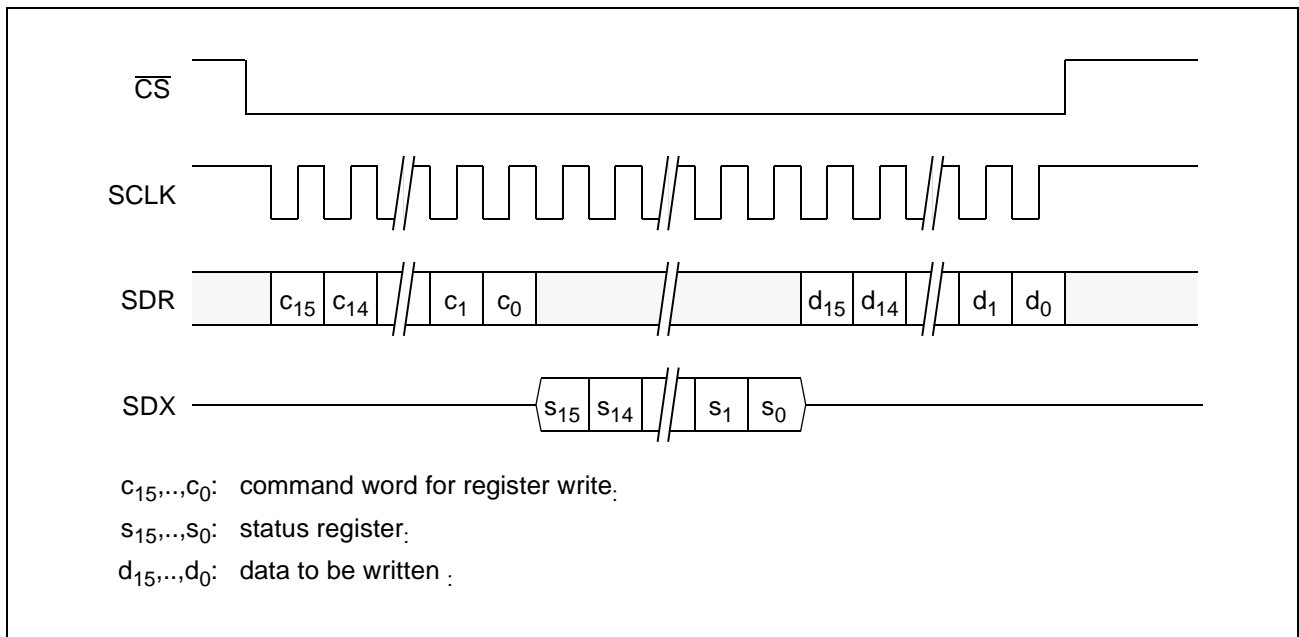

Figure 53 Register Write Access

Functional Description

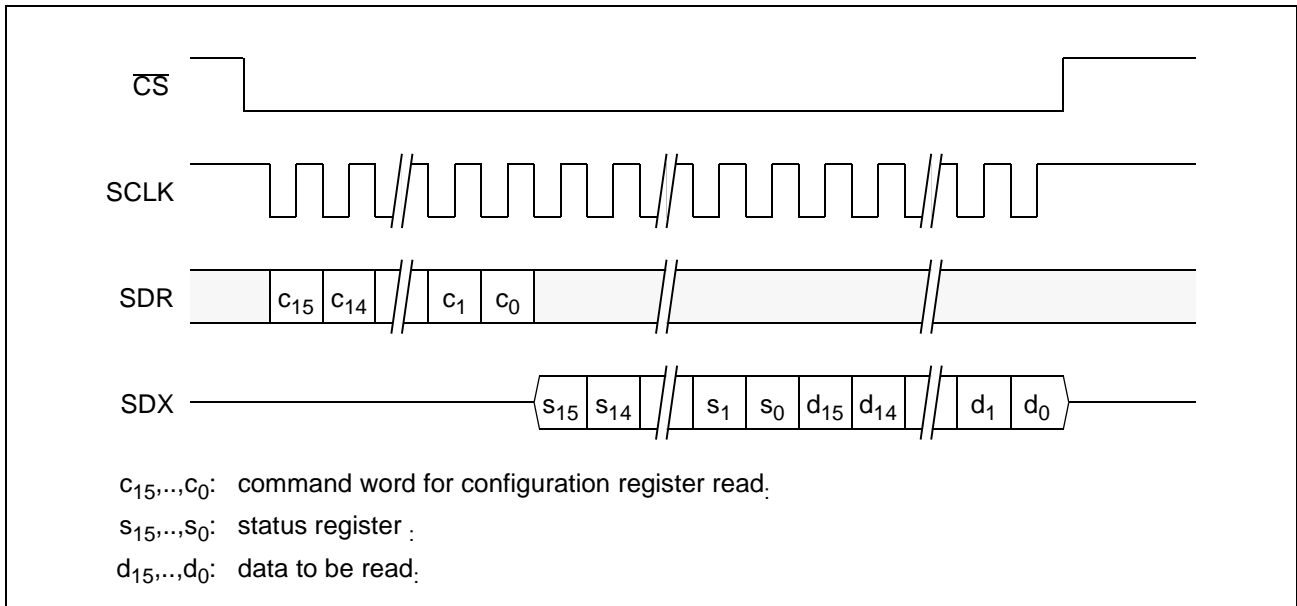

Figure 54 Configuration Register Read Access

Configuration registers at even addresses use bit positions d_7-d_0 while configuration registers at odd addresses use bit positions $d_{15}-d_8$.

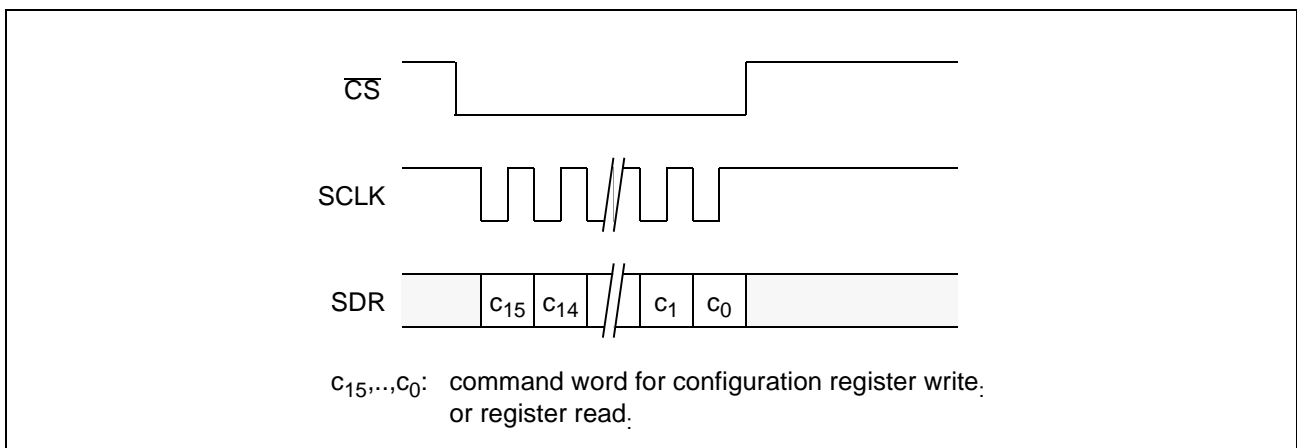

Figure 55 Configuration Register Write Access or Register Read Command

The internal interrupt signal is cleared when the first bit of the status register is put on SDX. However, externally the signal \overline{INT} is deactivated as long as \overline{CS} stays low. If the internal interrupt signal is not cleared or another event causing an interrupt occurs while the microcontroller is already reading the status belonging to the first event then INT goes low again immediately after \overline{CS} is removed. The timing is shown in figure 51. Table 76 shows the formats of the different command words. All other command words are reserved.

Functional Description

Table 76 Command Words for Register Access

	15	14	13	12	11	10	9	8	7	6	5	4	3	2	1	0
Read Status Register or Data Read Access	0	0	1	1	0	0	0	0	0	0	0	0	0	0	0	0
Read Register	0	1	0	1	REG											
Write Register	0	1	0	0	REG											
Read Configuration Reg.	0	1	1	1	0	0	R	0	0	0	0	0	0	0	0	0
Write Configuration Reg.	0	1	1	0	0	0	W	DATA								

In case of a configuration register write, W determines which configuration register is to be written (table 77):

Table 77 Address Field W for Configuration Register Write

9	8	Register
0	0	HWCONFIG 0
0	1	HWCONFIG 1
1	0	HWCONFIG 2
1	1	HWCONFIG 3

In case of a configuration register read, R determines which pair of configuration registers is to be read (table 78):

Table 78 Address Field R for Configuration Register Read

9	Register pair
0	HWCONFIG 0 / HWCONFIG 1
1	HWCONFIG 2 / HWCONFIG 3

Note: Reading any register except the status register or a hardware configuration register requires at least two accesses. The first access is a register read command (figure 55). With this access the register address is transferred to the. After that access data read accesses (figure 52) must be executed. The first data read access with STATUS:RDY=1 delivers the value of the register.

Functional Description

2.4.5 Memory Interface

The PSB 4860 supports either Flash Memory or ARAM/DRAM as external memory for storing messages. If ARAM/DRAM is used, an EPROM can be added optionally to support read-only messages (e.g. voice prompts). Table 79 summarizes the different configurations supported.

Table 79 Supported Memory Configurations

Mbit	Type	Bank 0 (D ₀ -D ₃)	Bank 1 (D ₄ -D ₇)	Comment
1	ARAM/DRAM	256kx4	-	
2	ARAM/DRAM	256kx4	256kx4	
4	ARAM/DRAM	1Mx4	-	
4	ARAM/DRAM	512kx8		
8	ARAM/DRAM	1Mx4	1Mx4	
16	ARAM/DRAM	4Mx4	-	2k or 4k refresh
16	ARAM/DRAM	2Mx8		2k refresh
32	ARAM/DRAM	4Mx4	4Mx4	2k or 4k refresh
32	ARAM/DRAM	2x2Mx8		2k refresh
64	ARAM/DRAM	16Mx4	-	4k or 8k refresh
64	ARAM/DRAM	8Mx8		4k or 8k refresh
128	ARAM/DRAM	16Mx4	16Mx4	4k or 8k refresh
4-128	FLASH	512kx8 devices		KM29N040
16-128	FLASH	2Mx8 devices		KM29N16000

If ARAM/DRAM is used, the total amount of memory must be a power of two and all devices must be of the same type. The pin FRDY must be tied high.

For flash devices, the PSB 4860 supports in-circuit programming of voice prompts by releasing the control lines during reset and (optionally) power down. Instead of actively driving the lines \overline{FCS} , \overline{FOE} , \overline{FWE} , \overline{FCLE} and \overline{ALE} these lines are pulled high by a weak pullup during reset and (optionally) power down.

Functional Description

2.4.5.1 ARAM/DRAM Interface

The PSB 4860 supports up to two banks of memory which may be 4 bit or 8 bit wide (Figure 56). If both banks are used they must be populated identically.

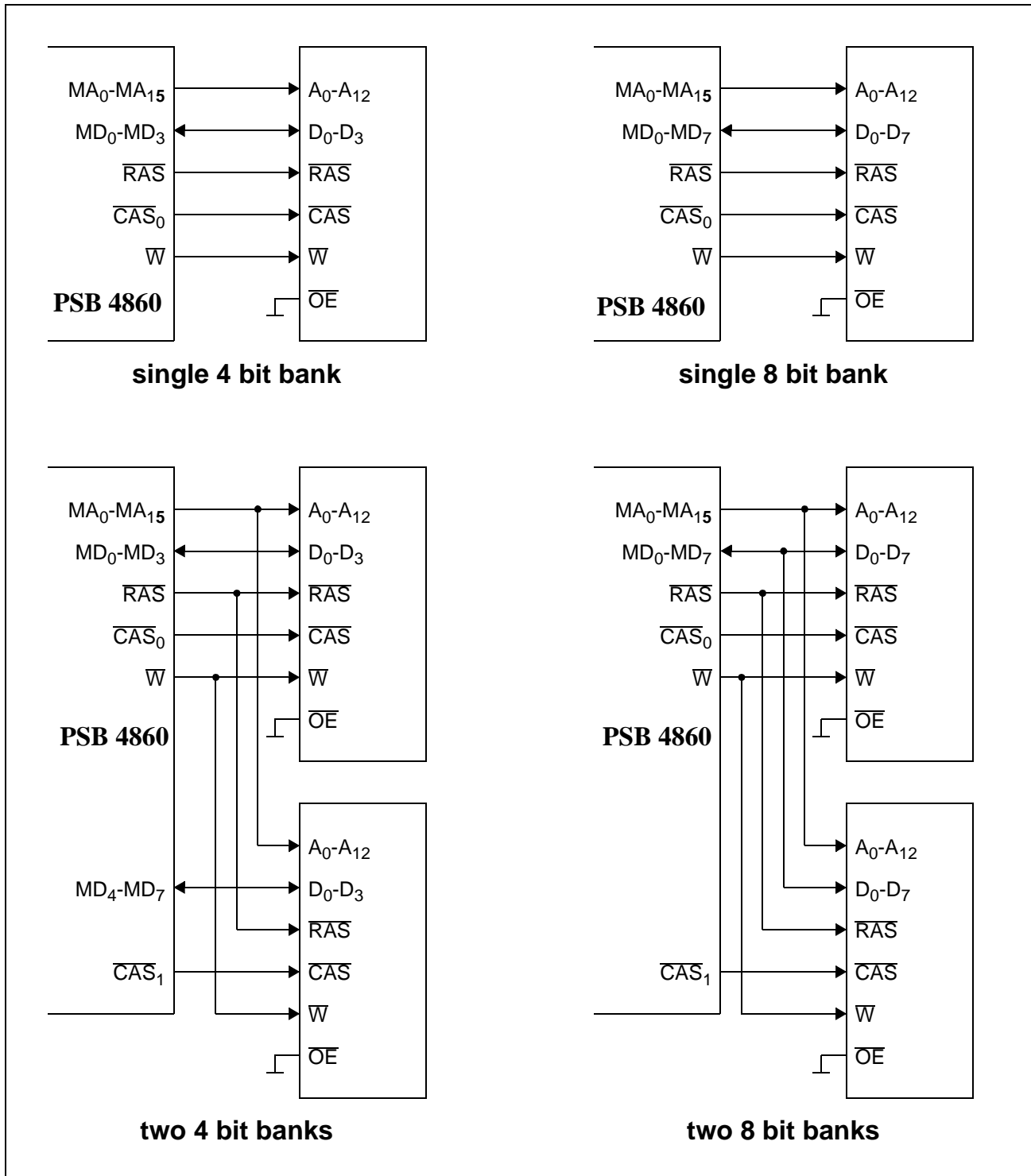

Figure 56 ARAM/DRAM Interface - Connection Diagram

Functional Description

The PSB 4860 also supports different internal organizations of ARAM/DRAM chips. Table 80 shows the necessary connections on the address bus.

Table 80 Address Line Usage (ARAM/DRAM Mode)

ARAM/DRAM	CS9 ¹⁾	MA ₀ -MA ₈	MA ₉	MA ₁₀	MA ₁₁	MA ₁₂	MA ₁₃
256k x4	1	A ₀ -A ₈					
512k x8	1	A ₀ -A ₈	A ₉				
1M x4	0	A ₀ -A ₈	A ₉				
4M x4 (2k refresh)	0	A ₀ -A ₈	A ₉	A ₁₀			
4M x4 (4k refresh)	0	A ₀ -A ₈	A ₉	A ₁₀	A ₁₁		
2M x8	0	A ₀ -A ₈	A ₉	A ₁₀			
16M x4 (4k refresh)	0	A ₀ -A ₈	A ₉	A ₁₀		A ₁₁	
16M x4 (8k refresh)	0	A ₀ -A ₈	A ₉	A ₁₀		A ₁₁	A ₁₂
8M x8 (4k refresh)	0	A ₀ -A ₈	A ₉	A ₁₀		A ₁₁	
8M x8 (8k refresh)	0	A ₀ -A ₈	A ₉	A ₁₀		A ₁₁	A ₁₂

¹⁾ see chip control register CCTL

The timing of the ARAM/DRAM interface is shown in figures 57 to 59. The timing is derived from the internal memory clock MCLK* which runs at a quarter of the system clock.

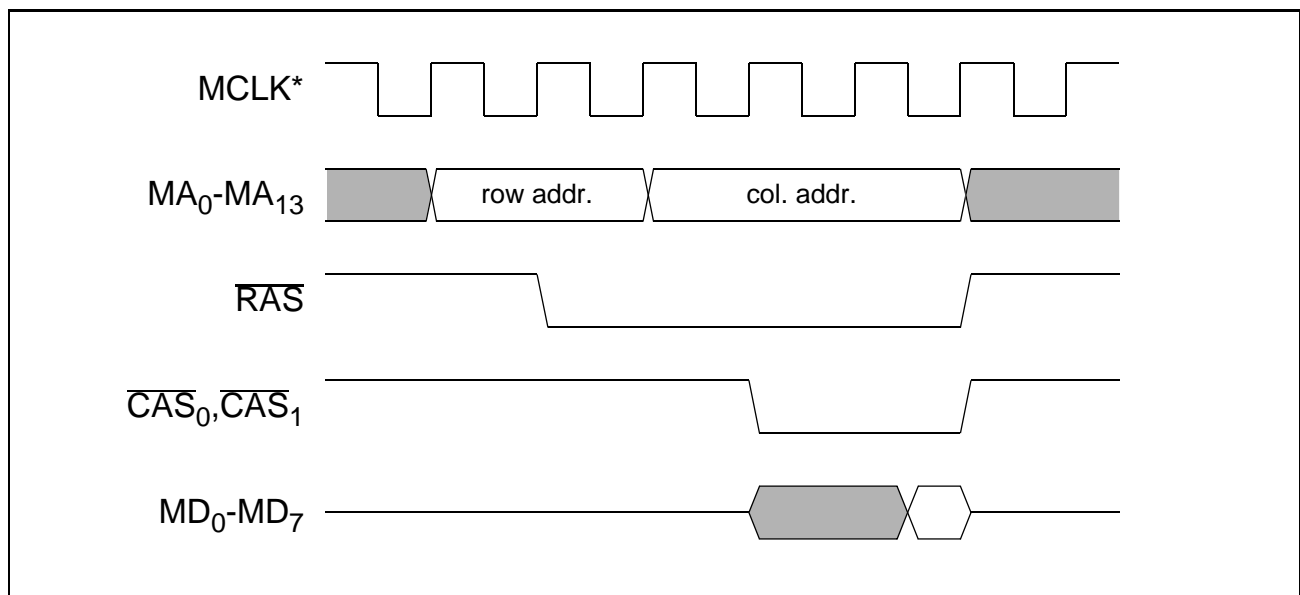

Figure 57 ARAM/DRAM Interface - Read Cycle Timing

Functional Description

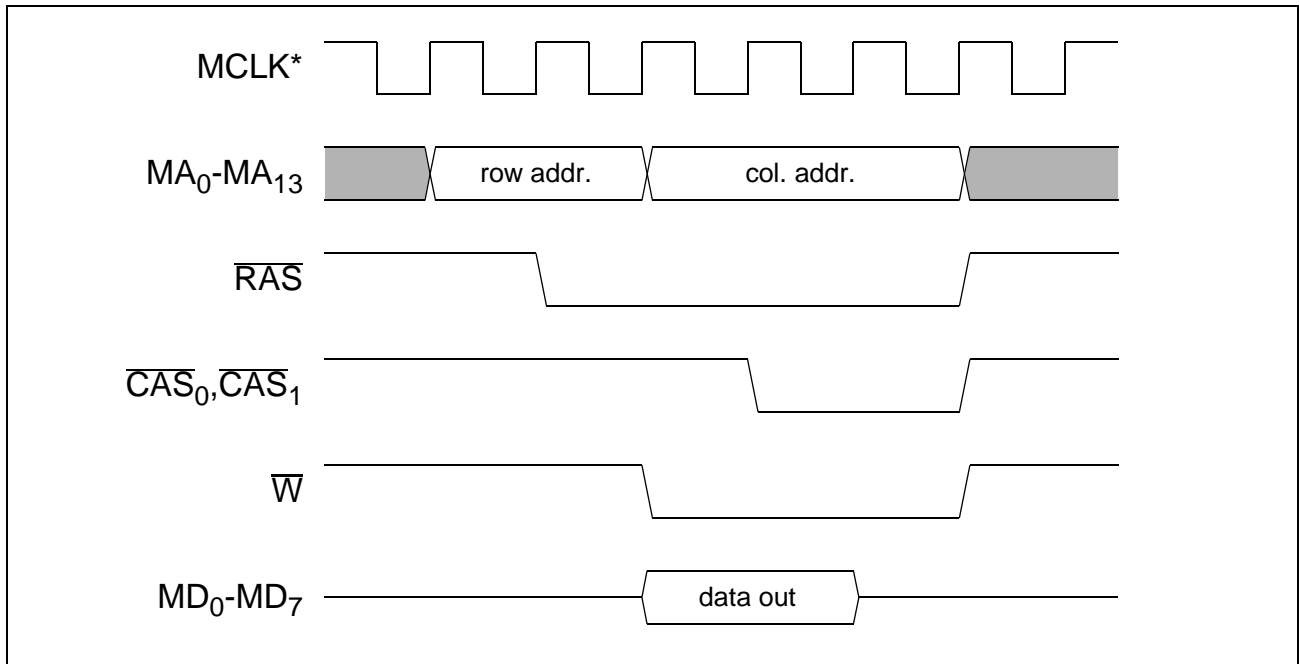

Figure 58 ARAM/DRAM Interface - Write Cycle Timing

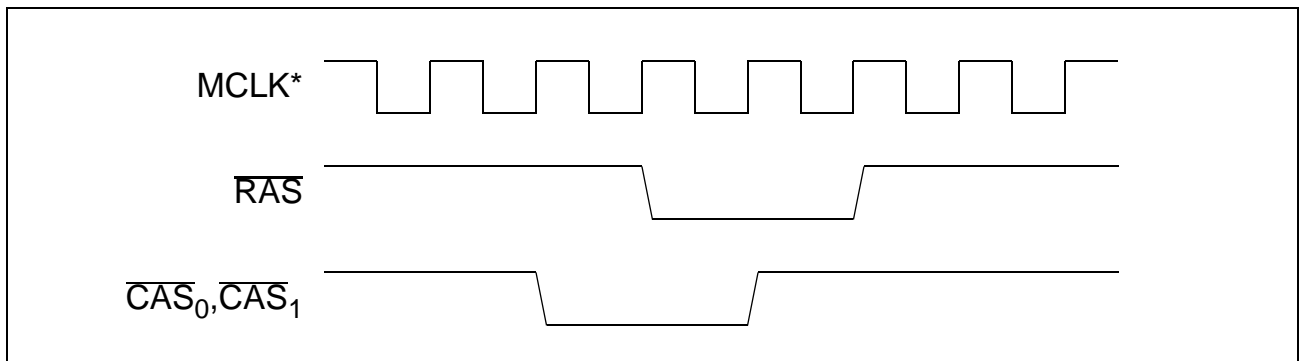

Figure 59 ARAM/DRAM Interface - Refresh Cycle Timing

The PSB 4860 ensures that \overline{RAS} remains inactive for at least one MCLK*-cycle between successive accesses.

The frequency at which refresh cycles are performed is shown in table 81.

Table 81 Refresh Frequency Selection

Refresh frequency	Comment
64 kHz	Memory access (e.g. recording) in progress
8, 16, 32 or 64 kHz ¹⁾	No memory access in progress or power-down

¹⁾ as programmed by HWCONFIG2:RSEL

2.4.5.2 EPROM Interface

The PSB 4860 supports an EPROM in parallel with ARAM/DRAM. This interface is always 8 Bits wide and supports a maximum of 256 kB. Figure 60 shows a connection diagram and figure 61 the timing. This interface supports read cycles only.

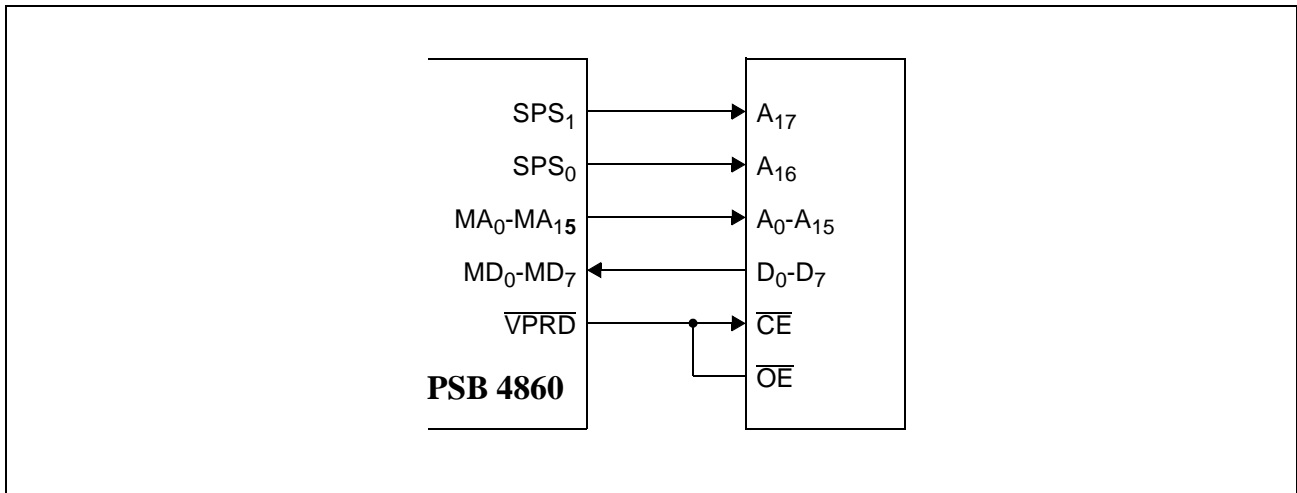

Figure 60 EPROM Interface - Connection Diagram

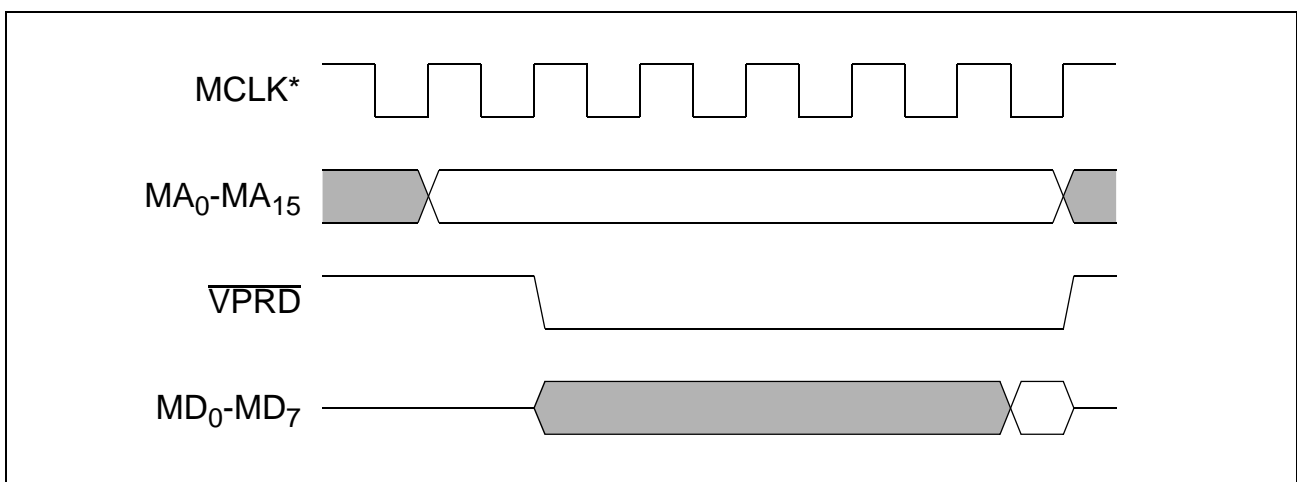

Figure 61 EPROM Interface - Read Cycle Timing

Note: In order to access more than 64 kB the pins SPS₀ and SPS₁ can be programmed to provide the address lines A₁₆ and A₁₇. In this mode A₁₆ and A₁₇ remain stable during the whole read cycle. See the register SPSCTL for programming information.

Functional Description

2.4.5.3 Flash Memory Interface

The PSB 4860 has special support for the KM29N040 and KM29N16000 or equivalent devices. No external components are required for up to four KM29N040. Figure 62 shows the connection diagram for a single device.

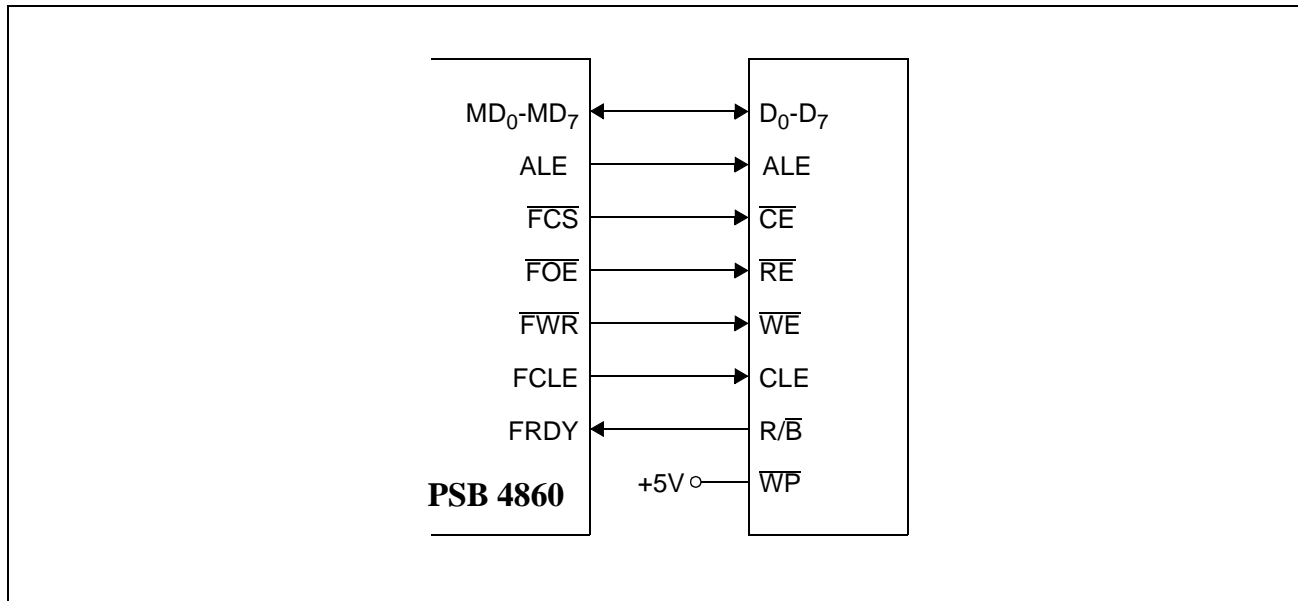

Figure 62 Flash Memory Interface - Connection Diagram

Table 82 shows the signals output during a device access on the MA-lines. The address bits can be used by an external decoder. Up to four KM29N040 are supported directly by the decoded select signals \overline{FCS}_0 - \overline{FCS}_3 .

Table 82 Address Line Usage (Samsung Mode)

MA ₁₁	MA ₁₀	MA ₉	MA ₈	MA ₇	MA ₆	MA ₅	MA ₄	MA ₃	MA ₂	MA ₁	MA ₀
\overline{FCS}_3	\overline{FCS}_2	\overline{FCS}_1	\overline{FCS}_0	A ₂₃	A ₂₂	A ₂₁	A ₂₀	A ₁₉	A ₁₈	A ₁₇	A ₁₆

Functional Description

Figure 63 shows an application with three KM29N040 devices.

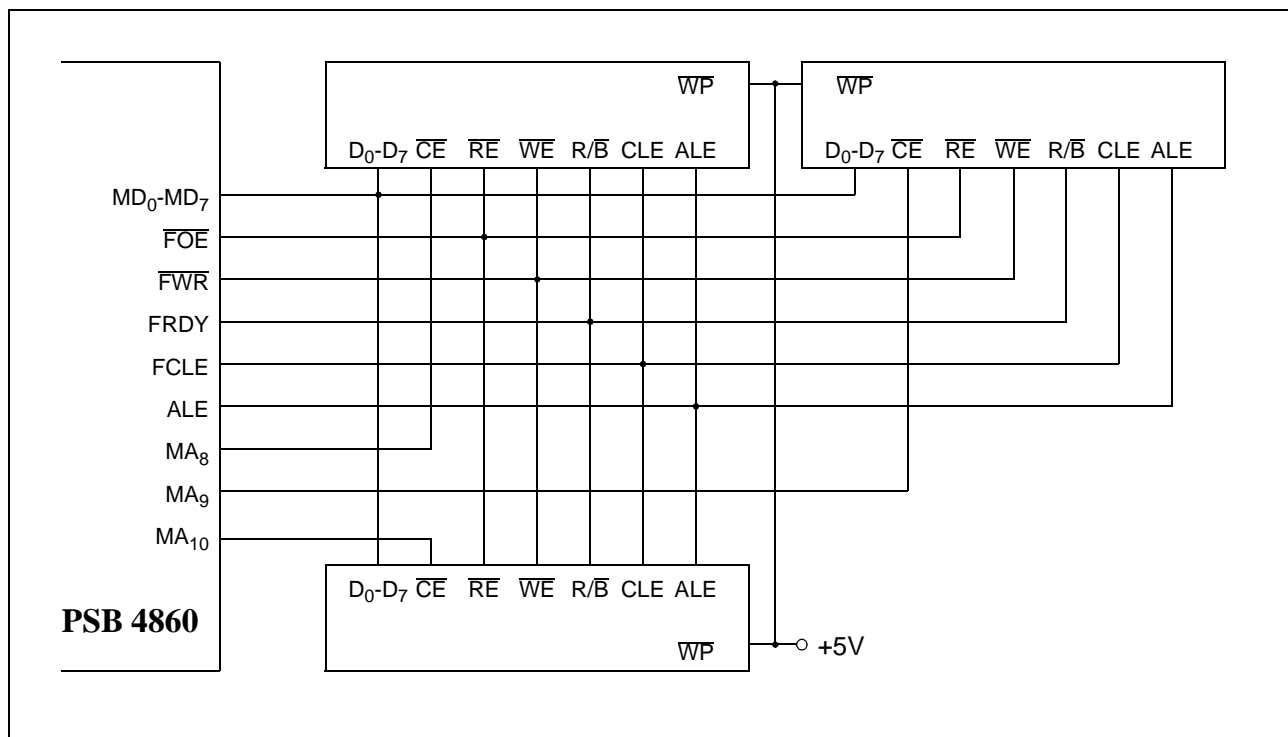

Figure 63 Flash Memory Interface - Multiple Devices

An access to the Flash Memory can consist of several partial access cycles where only the timing of the partial access cycles is defined but not the time between two adjacent partial access cycles. The PSB 4860 performs three types of partial access cycles:

1. Command write
2. Address write
3. Data read/write

Table 83 shows the supported accesses and the corresponding partial access cycles.

Table 83 Flash Memory Command Summary

Access	Command write	Address write 1	Address write 2	Address write 3	# of Data read/write	Command write
RESET	FF	-	-	-	-	-
STATUS READ	70	-	-	-	1	-
BLOCK ERASE	60	A ₈ -A ₁₅	A ₁₆ -A ₂₃	-	-	D0
READ	00	A ₀ -A ₇	A ₈ -A ₁₅	A ₁₆ -A ₂₃	1-32	-
WRITE	80	A ₀ -A ₇	A ₈ -A ₁₅	A ₁₆ -A ₂₃	1-32	10

Functional Description

The timing for the partial access cycles is shown in figures 64 to 65. Note that both \overline{FCS} and MA_0-MA_{15} remain stable between the first and the last partial access of a device access.

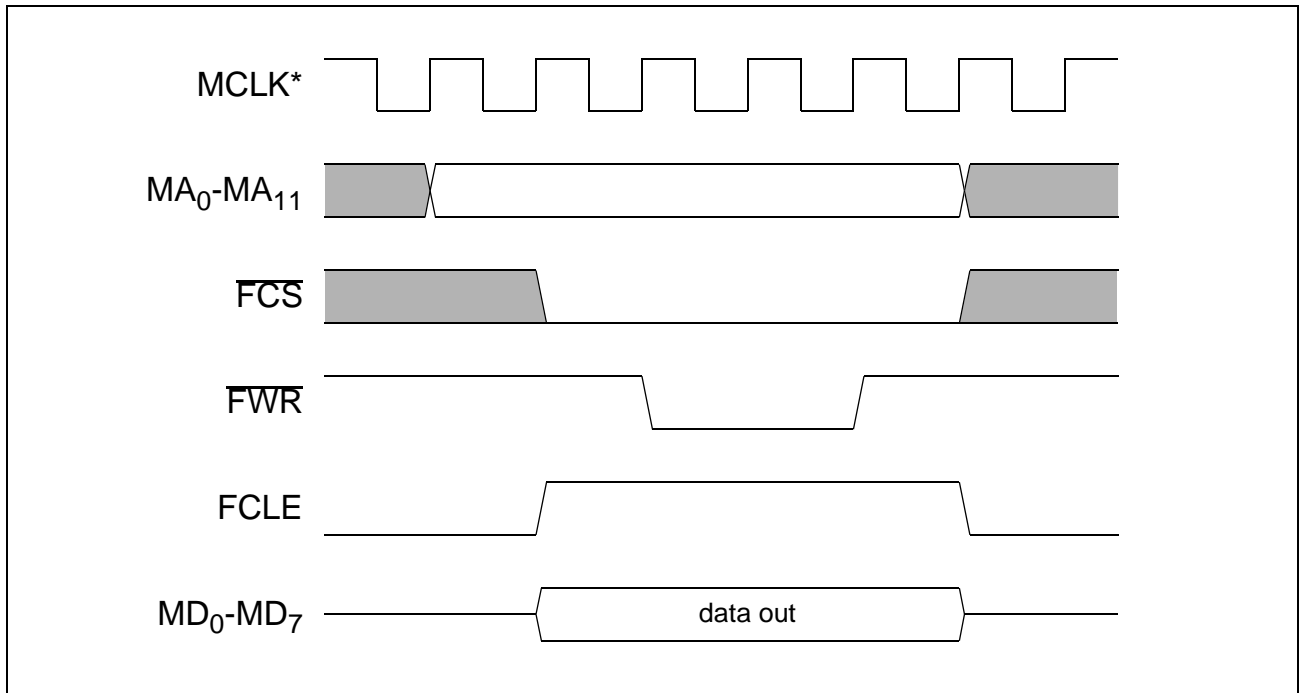

Figure 64 Flash Memory Interface - Command Write

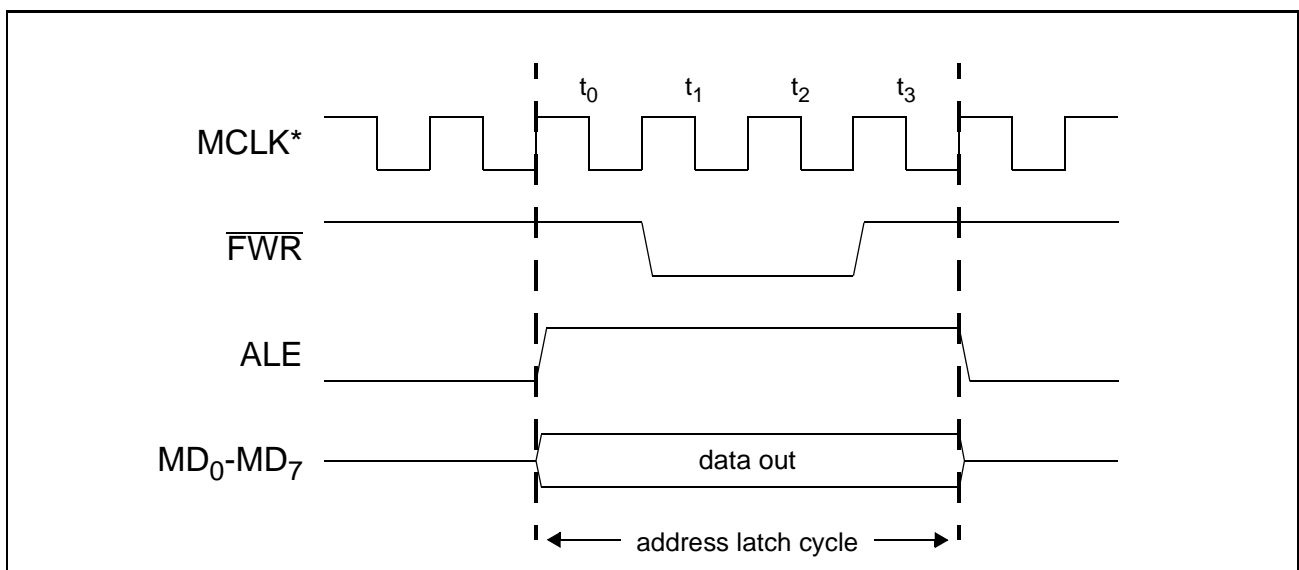

Figure 65 Flash Memory Interface - Address Write

As there is no access that starts or stops with an address write cycle (figure 65) \overline{FCS} is already low at the start of this cycle and also remains low.

Functional Description

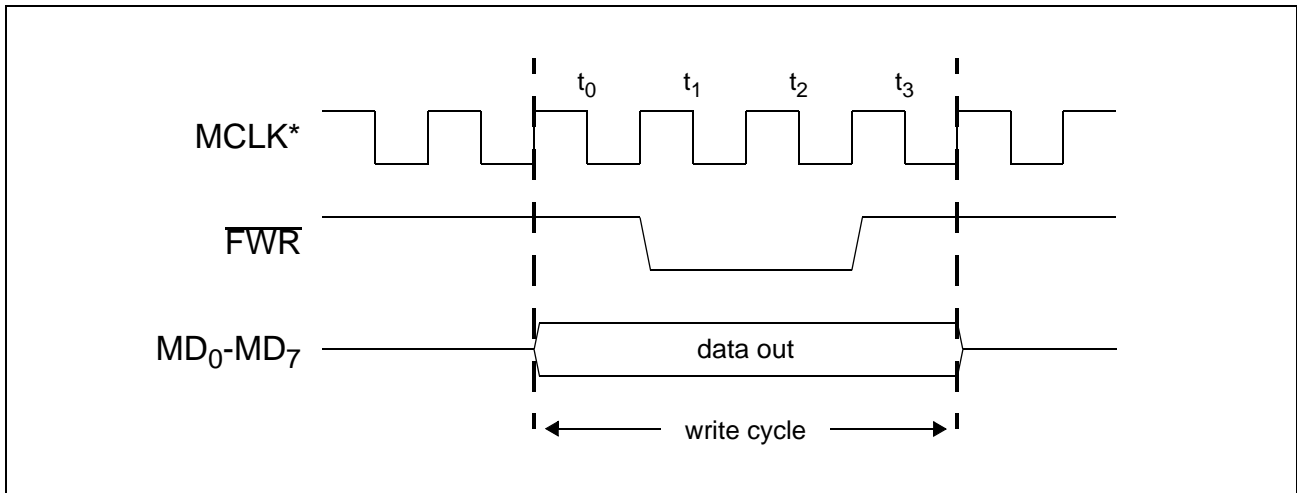

Figure 66 Flash Memory Interface - Data Write

As there is no access that starts or stops with a data write cycle (figure 66) \overline{FCS} is already low at the start of this cycle and also remains low.

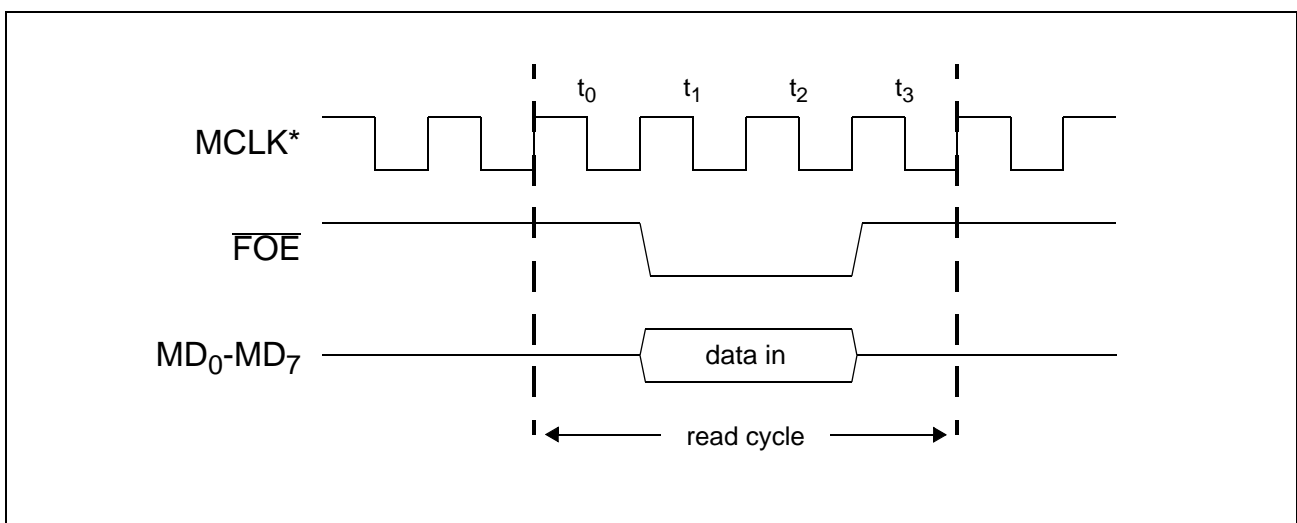

Figure 67 Flash Memory Interface - Data Read

If the device access ends with a read cycle, the \overline{FCS} -signals go inactive after t_3 of the last read cycle. The data is latched at the rising edge of \overline{FOE} .

Functional Description

2.4.6 Auxiliary Parallel Port

The PSB 4860 provides an auxiliary parallel port if the memory interface is in Samsung mode and only one device is used. In this case the lines MA_0 to MA_{15} are not needed for the memory interface and can therefore be used for an auxiliary parallel port. This port has two modes: static mode and multiplex mode.

2.4.6.1 Static Mode

In static mode all pins of the auxiliary parallel port interface have identical functionality. Any pin can be configured as an output or an input. Pins configured as outputs provide a static signal as programmed by the controller. Pins configured as inputs are monitoring the signal continuously without latching. The controller always reads the current value. Table 84 shows the registers used for static mode.

Table 84 Static Mode Registers

Register	# of bits	Comment
DOUT3	16	Output signals (for pins configured as outputs)
DIN	16	Input signals (for pins configured as inputs)
DDIR	16	Pin direction

2.4.6.2 Multiplex Mode

In multiplex mode, the PSB 4860 uses MA_{12} - MA_{15} to distinguish four timeslots. Each timeslot has a duration of approximately 2 ms. The timeslots are separated by a gap of approximately 125 μ s in which none of the signals at MA_{12} - MA_{15} are active. The PSB 4860 multiplexes three more output registers to MA_0 - MA_{11} in timeslots 0, 1 and 2. In timeslot 3 the direction of the pins can be programmed. For input pins, the signal is latched at the falling edge of MA_{15} . Table 85 shows the registers used for multiplex mode.

This mode is useful for scanning keys or controlling seven segment LED displays.

Table 85 Multiplex Mode Registers

Register	# of bits	Comment
DOUT0	12	Output signals on MA_0 - MA_{11} while $MA_{15}=1$
DOUT1	12	Output signals on MA_0 - MA_{11} while $MA_{14}=1$
DOUT2	12	Output signals on MA_0 - MA_{11} while $MA_{13}=1$
DOUT3	12	Output signals (for pins configured as outputs) while $MA_{12}=1$
DIN	12	Input signals (for pins configured as inputs) at falling edge of MA_{12}
DDIR	12	Pin direction during $MA_{12}=1$

Functional Description

Figure 68 shows the timing diagram for multiplex mode.

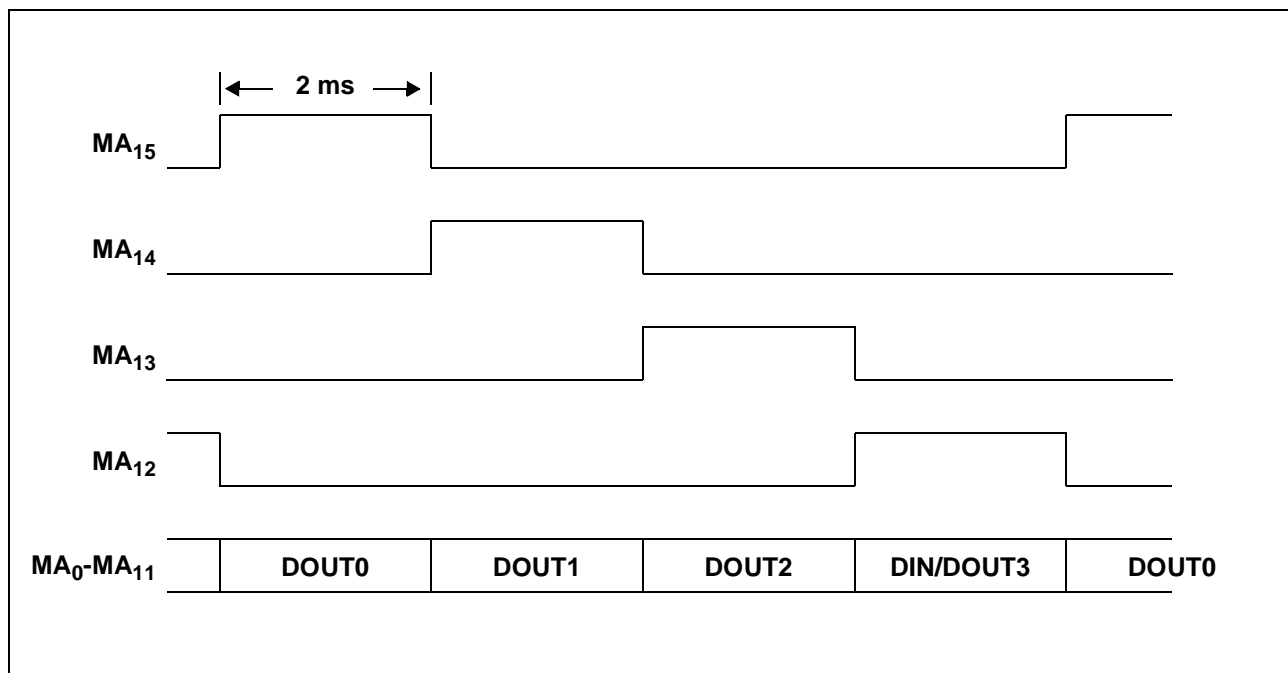

Figure 68 Auxiliary Parallel Port - Multiplex Mode

Note: In either mode the voltage at any pin (MA₀ to MA₁₅) must not exceed V_{DD}.

Detailed Register Description

3 Detailed Register Description

The PSB 4860 has a single status register (read only) and an array of data registers (read/write). The purpose of the status register is to inform the external microcontroller of important status changes of the PSB 4860 and to provide a handshake mechanism for data register reading or writing. If the PSB 4860 generates an interrupt, the status register contains the reason of the interrupt.

3.1 Status Register

15													0		
RDY	ABT	0	0	CIA	CD	CPT	CNG	SD	ERR	BSY	DTV	ATV	¹⁾	¹⁾	¹⁾

¹⁾ undefined

RDY **Ready**

- 0: The last command (if any) is still in progress.
- 1: The last command has been executed.

ABT **Abort**

- 0: No exception during operation
- 1: Some exception other than reset caused the PSB 4860 to abort any operation currently in progress. The external microcontroller should reinitialize the PSB 4860 to ensure proper operation. The ABT bit is cleared by writing any value to register REV. No other command is accepted by the PSB 4860 while ABT is set.

CIA **Caller ID Available**

- 0: No new data for caller ID
- 1: New caller ID byte available

CD **Carrier Detect**

- 0: No carrier detected
- 1: Carrier detected

Detailed Register Description**CPT Call Progress Tone**

- 0: Currently no call progress tone detected or pause detected (raw mode)
- 1: Currently a call progress is detected

CNG Fax Calling Tone

- 0: Currently no fax calling tone detected
- 1: Currently a fax calling tone is detected

SD Speech Detected

- 0: No speech detected
- 1: Speech signal at input of coder

ERR Error (File Command)

- 0: No error
- 1: Last file command resulted in an error

BSY Busy (File Command)

- 0: File system idle
- 1: File system still busy (also set during encoding/decoding)

DTV DTMF Tone Valid

- 0: No new DTMF code available
- 1: New DTMF code available in DDCTL

ATV Alert Tone Valid

- 0: No new alert tone code available
- 1: New alert tone code available in ADCTL0

3.2 Hardware Configuration Registers

HWCONFIG 0 - Hardware Configuration Register 0

7				0			
PD	ACS	RTC	OSC	PPSDI	$\overline{\text{PFRDY}}$	PPINT	PPSDX

PPSDX Push/Pull for SDX

- 0: The SDX pin has open-drain characteristic
- 1: The SDX pin has push/pull characteristic

PPINT Push/Pull for $\overline{\text{INT}}$

- 0: The $\overline{\text{INT}}$ pin has open-drain characteristic
- 1: The $\overline{\text{INT}}$ pin has push/pull characteristic

$\overline{\text{PFRDY}}$ Pullup for FRDY

- 0: The internal pullup resistor of pin $\overline{\text{FRDY}}$ is enabled
- 1: The internal pullup resistor of $\overline{\text{FRDY}}$ is disabled

PPSDI Push/Pull for SDI interface

- 0: The DU and DD pins have open-drain characteristic
- 1: The DU and DD pins have push/pull characteristic

OSC Enable Auxiliary Oscillator

- 0: The auxiliary oscillator (OSC₁, OSC₂) is disabled
- 1: The auxiliary oscillator (OSC₁, OSC₂) is enabled

RTC Enable Real Time Clock

- 0: The real time clock is disabled
- 1: The real time clock (RTC) is enabled.

ACS AFE Clock Source

- 0: AFECLK is derived from the main oscillator
- 1: AFECLK is derived from the CLK input

PD Power Down (read only)

- 0: The PSB 4860 is in active mode
- 1: The PSB 4860 is in power down mode

Detailed Register Description

HWCONFIG 1 - Hardware Configuration Register 1

7	0
APP	SSDI

APP Auxiliary Parallel Port

7	6	Description
0	0	normal (ARAM/DRAM, Intel type flash, voice prompt EPROM)
0	1	APP static mode
1	0	APP multiplex mode
1	1	reserved

ACT AFE Clock Tracking

- 0: AFECLK tracking disabled
- 1: AFECLK tracking enabled

ADS AFE Double Speed

- 0: 8 kHz AFEFSC
- 1: 16 kHz AFEFSC

MFS Master Frame Sync Selection

- 0: AFEFSC
- 1: FSC

XTAL XTAL Frequency

2	1	Factor p ¹⁾	Description
0	0	reserved	reserved
0	1	4.5	31.104 MHz
1	0	reserved	reserved
1	1	reserved	reserved

¹⁾ The factor p is needed to calculate the clock frequency at AFECLK.

SSDI SSDI Interface Selection

- 0: IOM[®]-2 Interface
- 1: SSDI Interface

Detailed Register Description

HWCONFIG 2 - Hardware Configuration Register 2

7						0
PPM	ESDX	ESDR	CSEL	CHS	RSEL	

PPM Push/Pull for Memory Interface (reset, power down)

- 0: The signals for the memory interface have push/pull characteristic
- 1: The signals for the memory interface have pullup/pulldown characteristic

ESDX Edge Select for DX

- 0: DX is transmitted with the rising edge of DCL
- 1: DX is transmitted with the falling edge of DCL

ESDR Edge Select for DR

- 0: DR is latched with the falling edge of DCL
- 1: DR is latched with the rising edge of DCL

CSEL Codec Selection for AFE interface

- 0: Interface to PSB 4851
- 1: Interface to AK 4510

CHS Channel Select (AK 4510 only)

3	2	Description
0	0	left channel of AK 4510
0	1	right channel of AK4510
1	0	left and right channel
1	1	reserved

RSEL Refresh Select

1	0	Description
0	0	64 kHz refresh frequency
0	1	32 kHz refresh frequency
1	0	16 kHz refresh frequency
1	1	8 kHz refresh frequency

Detailed Register Description

HWCONFIG 3 - Hardware Configuration Register 3

7							0
0	0	0	0	0	0	0	0

Detailed Register Description

3.3 Read/Write Registers

The following sections contains all read/write registers of the PSB 4860. The register addresses are given as hexadecimal values. Registers marked with an R are affected by reset or a wake up after power down. All other registers retain their previous value. No access must be made to addresses other than those associated with a read/write register.

3.3.1 Register Table

Address.	Name	Long Name	Page
00h	REV	Revision.....	119
01h R	CCTL	Chip Control	120
02h R	INTM	Interrupt Mask Register	121
03h R	AFECTL	Analog Front End Interface Control.....	122
04h R	IFS1	Interface Select 1	123
05h R	IFG1	Interface Gain 1	124
06h R	IFG2	Interface Gain 2.....	125
07h R	IFS2	Interface Select 2	126
08h R	IFG3	Interface Gain 3.....	127
09h R	IFG4	Interface Gain 4.....	128
0Ah R	SDCONF	Serial Data Interface Configuration	129
0Bh R	SDCHN1	Serial Data Interface Channel 1	130
0Ch R	IFS3	Interface Select 3	132
0Dh R	SDCHN2	Serial Data Interface Channel 2	133
0Eh R	IFS4	Interface Select 4	134
0Fh R	IFG5	Interface Gain 5.....	135
10h R	UA	Universal Attenuator.....	136
11h R	DGCTL	DTMF Generator Control.....	137
12h	DGF1	DTMF Generator Frequency 1	138
13h	DGF2	DTMF Generator Frequency 2	139
14h	DGL	DTMF Generator Level.....	140
15h	DGATT	DTMF Generator Attenuation	141
16h R	CNGCTL	Calling Tone Control.....	142
17h	CNGBT	CNG Burst Time	143
18h	CNGLEV	CNG Minimal Signal Level	144
19h	CNGRES	CNG Signal Resolution	145
1Ah R	ATDCTL0	Alert Tone Detection 0.....	146
1Bh	ATDCTL1	Alert Tone Detection 1.....	147
1Ch R	CIDCTL0	Caller ID Control 0.....	148
1Dh	CIDCTL1	Caller ID Control 1.....	149
20h R	CPTCTL	Call Progress Tone Control	150
21h	CPTTR	Call Progress Tone Thresholds.....	151
22h	CPTMN	CPT Minimum Times.....	152

Detailed Register Description

23h	CPTMX	CPT Maximum Times.....	153
24h	CPTDT	CPT Delta Times.....	154
25h R	LECCTL	Line Echo Cancellation Control.....	155
26h	LECLEV	Minimal Signal Level for Line Echo Cancellation.....	156
27h	LECATT	Externally Provided Attenuation.....	157
28h	LECMGN	Margin for Double Talk Detection.....	158
29h R	DDCTL	DTMF Detector Control.....	159
2Ah	DDTW	DTMF Detector Signal Twist.....	160
2Bh	DDLEV	DTMF Detector Minimum Signal Level.....	161
2Eh R	FCFCTL	Equalizer Control.....	162
2Fh	FCFCOF	Equalizer Coefficient Data.....	164
30h R	SCCTL	Speech Coder Control.....	165
31h	SCCT2	Speech Coder Control 2.....	166
32h	SCCT3	Speech Coder Control 3.....	167
34h R	SDCTL	Speech Decoder Control.....	168
38h R	AGCCTL	AGC Control.....	169
39h R	AGCATT	Automatic Gain Control Attenuation.....	170
3Ah	AGC1	Automatic Gain Control 1.....	171
3Bh	AGC2	Automatic Gain Control 2.....	172
3Ch	AGC3	Automatic Gain Control 3.....	173
3Dh	AGC4	Automatic Gain Control 4.....	174
3Eh	AGC5	Automatic Gain Control 5.....	175
40h R	FCTL	File Control.....	176
41h R	FCMD	File Command.....	177
42h R	FDATA	File Data.....	179
43h R	FPTR	File Pointer.....	180
47h R	SPSCTL	SPS Control.....	181
48h R	RTC1	Real Time Clock 1.....	182
49h R	RTC2	Real Time Clock 2.....	183
4Ah R	DOUT0	Data Out (Timeslot 0).....	184
4Bh R	DOUT1	Data Out (Timeslot 1).....	185
4Ch R	DOUT2	Data Out (Timeslot 2).....	186
4Dh R	DOUT3	Data Out (Timeslot 3 or Static Mode).....	187
4Eh	DIN	Data In (Timeslot 3 or Static Mode).....	188
4Fh R	DDIR	Data Direction (Timeslot 3 or Static Mode).....	189
60h R	SCTL	Speakerphone Control.....	190
62h R	SSRC1	Speakerphone Source 1.....	191
63h R	SSRC2	Speakerphone Source 2.....	192
64h	SSDX1	Speech Detector (Transmit) 1.....	193
65h	SSDX2	Speech Detector (Transmit) 2.....	194
66h	SSDX3	Speech Detector (Transmit) 3.....	195
67h	SSDX4	Speech Detector (Transmit) 4.....	196
68h	SSDR1	Speech Detector (Receive) 1.....	197

Detailed Register Description

69h	SSDR2	Speech Detector (Receive) 2	198
6Ah	SSDR3	Speech Detector (Receive) 3	199
6Bh	SSDR4	Speech Detector (Receive) 4	200
6Ch	SSCAS1	Speech Comparator (Acoustic Side) 1	201
6Dh	SSCAS2	Speech Comparator (Acoustic Side) 2.....	202
6Eh	SSCAS3	Speech Comparator (Acoustic Side) 3.....	203
6Fh	SSCLS1	Speech Comparator (Line Side) 1	204
70h	SSCLS2	Speech Comparator (Line Side) 2.....	205
71h	SSCLS3	Speech Comparator (Line Side) 3.....	206
72h	SATT1	Attenuation Unit 1	207
73h	SATT2	Attenuation Unit 2.....	208
74h	SAGX1	Automatic Gain Control (Transmit) 1	209
75h	SAGX2	Automatic Gain Control (Transmit) 2.....	210
76h	SAGX3	Automatic Gain Control (Transmit) 3.....	211
77h	SAGX4	Automatic Gain Control (Transmit) 4.....	212
78h	SAGX5	Automatic Gain Control (Transmit) 5.....	213
79h	SAGR1	Automatic Gain Control (Receive) 1	214
7Ah	SAGR2	Automatic Gain Control (Receive) 2.....	215
7Bh	SAGR3	Automatic Gain Control (Receive) 3.....	216
7Ch	SAGR4	Automatic Gain Control (Receive) 4.....	217
7Dh	SAGR5	Automatic Gain Control (Receive) 5.....	218
7Eh	SLGA	Line Gain	219
80h	SAELEN	Acoustic Echo Cancellation Length.....	220
81h	SAEATT	Acoustic Echo Cancellation Double Talk Attenuation	221
82h	SAEGS	Acoustic Echo Cancellation Global Scale	222
83h	SAEPS1	Acoustic Echo Cancellation Partial Scale.....	223
84h	SAEPS2	Acoustic Echo Cancellation First Block.....	224

Note: Registers CCTL, FCTL, FCMD, FDATA, FPTR, RTC1, RTC2, DOUT0, DOUT1, DOUT2, DOUT3 and DDIR are only affected by reset, not by wakeup. For register SPSCTL see the register description for the exact behaviour.

3.3.2 Register Naming Conventions

Several registers contain one or more fields for input signal selection. All fields labelled I₁ (I₂, I₃) are five bits wide and use the same coding as shown in table 86.

Table 86 Signal Encoding

4	3	2	1	0	Signal	Description
0	0	0	0	0	S ₀	Silence
0	0	0	0	1	S ₁	Analog line input (channel 1 of PSB 4851 interface)

Detailed Register Description

Table 86 Signal Encoding

4	3	2	1	0	Signal	Description
0	0	0	1	0	S ₂	Analog line output (channel 1 of PSB 4851 interface)
0	0	0	1	1	S ₃	Microphone input (channel 2 of PSB 4851 interface)
0	0	1	0	0	S ₄	Loudspeaker/Handset output (channel 2 of PSB 4851 interface)
0	0	1	0	1	S ₅	Serial interface input, channel 1
0	0	1	1	0	S ₆	Serial interface output, channel 1
0	0	1	1	1	S ₇	Serial interface input, channel 2
0	1	0	0	0	S ₈	Serial interface output, channel 2
0	1	0	0	1	S ₉	DTMF generator output
0	1	0	1	0	S ₁₀	DTMF generator auxiliary output
0	1	0	1	1	S ₁₁	Speakerphone output (acoustic side)
0	1	1	0	0	S ₁₂	Speakerphone output (line side)
0	1	1	0	1	S ₁₃	Speech decoder output
0	1	1	1	0	S ₁₄	Universal attenuator output
0	1	1	1	1	S ₁₅	Line echo canceller output
1	0	0	0	0	S ₁₆	AGC unit output (after AGC)
1	0	0	0	1	S ₁₇	AGC unit output (before AGC)
1	0	0	1	0	S ₁₈	Equalizer output
1	0	0	1	1		reserved
1	0	1	-	-		reserved
1	1	-	-	-		reserved

Detailed Register Description

00_h REV Revision

15														0	
0	0	0	1	0	0	0	0	0	0	0	0	0	0	0	0

The revision register can only be read. For the PSB 4860, V2.1, all bits except bit 12 are zero.

Note: A write access to the revision register does not alter its content. It does, however, reset the ABT bit of the STATUS register.

Detailed Register Description

01_h CCTL Chip Control

15															0
0	0	0	0	MV	0	0	PD	0	0	0	MQ	MT	CS9	SAS	
Reset Value															
0	0	0	0	0	0	0	0	0	0	0	0	0	0	0	0

MV Voice Prompt Directory
 0: not available
 1: available (within EPROM or Flash)

PD Power Down
 0: PSB 4860 is in active mode
 1: enter power-down mode

MQ Memory Quality
 0: ARAM
 1: DRAM

MT Memory Type

3	2	Description
0	0	ARAM/DRAM
1	1	Samsung flash memory

CS9 CAS selection
 0: other memory
 1: 256kx4 or 512kx8 memory

SAS Split Address Space
 0: other ARAM/DRAM
 1: two 2Mx8 devices

Detailed Register Description

02_h INTM Interrupt Mask Register

													15					0
RDY	1	0	0	CIA	CD	CPT	CNG	SD	ERR	BSY	DTV	ATV	0	0	0			
Reset Value																		
0	1	0	0	0	0	0	0	0	0	0	0	0	0	0	0			

If a bit of this register is reset (set to 0), the corresponding bit of the status register does not generate an interrupt.

If a bit is set (set to 1), an external interrupt can be generated by the corresponding bit of the status register.

Detailed Register Description

03_h AFECTL Analog Front End Interface Control

15													0	
0	0	0	0	ALS			0	0	0	0	0	0	0	EN
Reset Value														
0	0	0	0	0			0	0	0	0	0	0	0	0

ALS Loudspeaker Amplification

This value is transferred on channel C3 of the AFE interface. If the PSB 4851 is used it represents the amplification of the loudspeaker amplifier.

EN Interface Enable

0: AFE interface disabled

1: AFE interface enabled

Detailed Register Description

04_h IFS1 Interface Select 1

15			0
HP	I1	I2	I3
Reset Value			
0	0	0	0

The signal selection fields I1, I2 and I3 of IFS1 determine the outgoing signal of channel 1 of the analog interface. For the PSB 4851 this is usually the line out signal.

The HP bit enables a high-pass for the incoming signal of channel 1 of the analog interface. For the PSB 4851 this is usually the line in signal.

HP High-Pass for S₁

0: Disabled

1: Enabled

I1 Input signal 1 for IG2

I2 Input signal 2 for IG2

I3 Input signal 3 for IG2

Note: As all sources are always active, unused sources must be set to 0 (S₀).

Detailed Register Description

05_h IFG1 Interface Gain 1

15	0
0	IG1
Reset Value	
0	8192 (0 dB)

IFG1 is associated with the incoming signal of channel 1 of the analog interface. For the PSB 4851 this is usually the line in signal.

IG1

In order to obtain a gain *G* the parameter IG1 can be calculated by the following formula:

$$IG1 = 32768 \times 10^{(G - 12.04 \text{ dB}) / 20 \text{ dB}}$$

Detailed Register Description

06_h IFG2 Interface Gain 2

15	0
0	IG2
Reset Value	
0	8192 (0 dB)

IFG2 is associated with the outgoing signal of channel 1 of the analog interface. For the PSB 4851 this is usually the line out signal.

IG2 Gain of Amplifier IG2

In order to obtain a gain G the parameter IG2 can be calculated by the following formula:

$$IG2 = 32768 \times 10^{(G - 12.04 \text{ dB}) / 20 \text{ dB}}$$

Detailed Register Description

07_h IFS2 Interface Select 2

15			0
HP	I1	I2	I3
Reset Value			
0	0	0	0

The signal selection fields I1, I2 and I3 of IFS2 determine the outgoing signal of channel 2 of the analog interface. For the PSB 4851 this is usually the loudspeaker signal.

The HP bit enables a high-pass for the incoming signal of channel 2 of the analog interface. For the PSB 4851 this is usually the microphone signal.

HP High-Pass for S₃

0: Disabled

1: Enabled

I1 Input signal 1 for IG4

I2 Input signal 2 for IG4

I3 Input signal 3 for IG4

Note: As all sources are always active, unused sources must be set to 0 (S₀).

Detailed Register Description

08_h IFG3 Interface Gain 3

15	0
0	IG3
Reset Value	
0	8192 (0 dB)

IFG3 is associated with the incoming signal of channel 2 of the analog interface. For the PSB 4851 this is usually the microphone signal.

IG3 Gain of Amplifier IG3

In order to obtain a gain G the parameter IG3 can be calculated by the following formula:

$$IG3 = 32768 \times 10^{(G - 12.04 \text{ dB}) / 20 \text{ dB}}$$

Detailed Register Description

09_h IFG4 Interface Gain 4

15	0
0	IG4
Reset Value	
0	8192 (0 dB)

IFG4 is associated with the outgoing signal of channel 2 of the analog interface. For the PSB 4851 this is usually the loudspeaker signal.

IG4 Gain of Amplifier IG4

In order to obtain a gain *G* the parameter IG4 can be calculated by the following formula:

$$IG4 = 32768 \times 10^{(G - 12.04 \text{ dB}) / 20 \text{ dB}}$$

Detailed Register Description

0A_h SDCONF Serial Data Interface Configuration

15										0				
0	0	NTS					0	0	0	0	0	DCL	0	EN
Reset Value														
0	0	0					0	0	0	0	0	0	0	0

NTS Number of Timeslots

13	12	11	10	9	8	Description
0	0	0	0	0	0	1
0	0	0	0	0	1	2
...
1	1	1	1	1	1	64

DCL Double Clock Mode

- 0: Single Clock Mode
- 1: Double Clock Mode

EN Enable Interface

- 0: Interface is disabled (both channels)
- 1: Interface is enabled (depending on separate channel enable bits)

Detailed Register Description

0B_h SDCHN1 Serial Data Interface Channel 1

15

0

NAS	0	0	PCD	EN	PCM	DD	TS
-----	---	---	-----	----	-----	----	----

Reset Value

0	0	0	0	0	0	0	0
---	---	---	---	---	---	---	---

NAS Number of active DRST strobe (SSDI interface mode)

15	14	13	12	Description
0	0	0	0	1
...
1	1	1	1	16

PCD PCM Code

0: A-law

1: μ -law

EN Enable Interface

0: Interface is disabled

1: Interface is enabled if SDCONF:EN=1

PCM PCM Mode

0: 16 Bit Linear Coding (two timeslots)

1: 8 Bit PCM Coding (one timeslot)

DD Data Direction

0: DD: Data Downstream, DU: Data Upstream

1: DD: Data Upstream, DU: Data Downstream

TS Timeslot for Channel 1

5	4	3	2	1	0	Description
0	0	0	0	0	0	0
...
1	1	1	1	1	1	63

Detailed Register Description

*Note: If PCM=0 then TS denotes the first timeslot of the two consecutive timeslots used.
Only even timeslots are allowed in this case.*

Detailed Register Description

0C_h IFS3 Interface Select 3

15			0
HP	I1	I2	I3
Reset Value			
0	0	0	0

The signal selection fields I1, I2 and I3 of IFS3 determine the outgoing signal of channel 1 of the IOM/SSDI-interface.

The HP bit enables a high-pass for the incoming signal of channel 1 of the analog IOM/SSDI-interface.

HP High-Pass for S₆

0: Disabled

1: Enabled

I1 Input signal 1 for S₅

I2 Input signal 2 for S₅

I3 Input signal 3 for S₅

Note: As all sources are always active, unused sources must be set to 0 (S₀).

Detailed Register Description

0D_h SDCHN2 Serial Data Interface Channel 2

15 **0**

0	0	0	0	0	0	PCD	EN	PCM	DD	TS
---	---	---	---	---	---	-----	----	-----	----	----

Reset Value

0	0	0	0	0	0	0	0	0	0	0
---	---	---	---	---	---	---	---	---	---	---

PCD PCM Code

- 0: A-law
- 1: μ -law

EN Enable Interface

- 0: Interface is disabled
- 1: Interface is enabled if SDCONF:EN=1

PCM PCM Mode

- 0: 16 Bit Linear Coding (two timeslots)
- 1: 8 Bit PCM Coding (one timeslot)

DD Data Direction

- 0: DD: Data Downstream, DU: Data Upstream
- 1: DD: Data Upstream, DD: Data Downstream

TS Timeslot for Channel 2

5	4	3	2	1	0	Description
0	0	0	0	0	0	0
0	0	0	0	0	1	1
...
1	1	1	1	1	1	63

Note: If PCM=0 then TS denotes the first timeslot of the two consecutive timeslots used. Only even timeslots are allowed in this case.

Detailed Register Description

0E_h IFS4 Interface Select 4

15			0
HP	I1	I2	I3
Reset Value			
0	0	0	0

The signal selection fields I1, I2 and I3 of IFS4 determine the outgoing signal of channel 2 of the IOM/SSDI-interface. The HP bit enables a high-pass for the incoming signal of channel 2.

HP High-Pass for S₇

0: Disabled

1: Enabled

I1 Input signal 1 for S₈

I2 Input signal 2 for S₈

I3 Input signal 3 for S₈

As all sources are always active, unused sources must be set to 0 (S₀).

Detailed Register Description

0F_h IFG5 Interface Gain 5

15	0
ATT1	ATT2
Reset Value	
255 (0 dB)	255 (0 dB)

ATT1 Attenuation for I3 (Channel 1)

In order to obtain an attenuation *A* the parameter ATT1 can be calculated by the following formula:

$$ATT1 = 256 \times 10^{A/20 \text{ dB}}$$

ATT2 Attenuation for I3 (Channel 2)

In order to obtain an attenuation *A* the parameter ATT2 can be calculated by the following formula:

$$ATT2 = 256 \times 10^{A/20 \text{ dB}}$$

Detailed Register Description

10_h UA Universal Attenuator

15 0

ATT	0	0	0	I1
-----	---	---	---	----

Reset Value

0 (-100 dB)	0	0	0	0
-------------	---	---	---	---

ATT Attenuation for UA

For a given attenuation A [dB] the parameter ATT can be calculated by the following formula:

$$ATT = 256 \times 10^{A/20 \text{ dB}}$$

I1 Input Selection for UA

Detailed Register Description

11_h DGCTL DTMF Generator Control

15

0

EN	MD	0	0	0	0	0	0	0	0	0	0	DTC
----	----	---	---	---	---	---	---	---	---	---	---	-----

Reset Value

0	0	0	0	0	0	0	0	0	0	0	0	0
---	---	---	---	---	---	---	---	---	---	---	---	---

EN Generator Enable

0: Disabled

1: Enabled

MD Mode

0: raw

1: cooked

DTC Dial Tone Code (cooked mode)

3	2	1	0	Digit	Frequency
0	0	0	0	1	697/1209
0	0	0	1	2	697/1336
0	0	1	0	3	697/1477
0	0	1	1	A	697/1633
0	1	0	0	4	770/1209
0	1	0	1	5	770/1336
0	1	1	0	6	770/1477
0	1	1	1	B	770/1633
1	0	0	0	7	852/1209
1	0	0	1	8	852/1336
1	0	1	0	9	852/1477
1	0	1	1	C	852/1633
1	1	0	0	*	941/1209
1	1	0	1	0	941/1336
1	1	1	0	#	941/1477
1	1	1	1	D	941/1633

Detailed Register Description**12_h DGF1 DTMF Generator Frequency 1**

15	0
0	FRQ

FRQ Frequency of Generator 1

The parameter FRQ for a given frequency f [Hz] can be calculated by the following formula:

$$\text{FRQ} = 32768 \times \frac{f}{4000\text{Hz}}$$

Detailed Register Description

13_h DGF2 DTMF Generator Frequency 2

15	0
0	FRQ

FRQ Frequency of Generator 2

The parameter FRQ for a given frequency f [Hz] can be calculated by the following formula:

$$FRQ = 32768 \times \frac{f}{4000\text{Hz}}$$

Detailed Register Description

14_h DGL DTMF Generator Level

15			0
0	LEV2	0	LEV1

LEV2 Signal Level of Generator 2

In order to obtain a signal level L (relative to the PCM maximum value) for generator 2 the value of LEV2 can be calculated according to the following formula:

$$LEV2 = 128 \times 10^{L/20 \text{ dB}}$$

LEV1 Signal Level of Generator 1

In order to obtain a signal level L (relative to the PCM maximum value) for generator 1 the value of LEV1 can be calculated according to the following formula:

$$LEV1 = 128 \times 10^{L/20 \text{ dB}}$$

Detailed Register Description

15_h DGATT DTMF Generator Attenuation

15

0

ATT2	ATT1
------	------

ATT2 Attenuation of Signal S₁₀

In order to obtain attenuation *A* the parameter ATT2 can be calculated by the formula:

$$ATT2 = \begin{cases} 128 + 1024 \times 10^{A/20 \text{ dB}} & ;A > 18, 1 \text{ dB} \\ 128 \times 10^{A/20 \text{ dB}} & ;A < 18, 1 \text{ dB} \end{cases}$$

ATT1 Attenuation of Signal S₉

In order to obtain attenuation *A* the parameter ATT1 can be calculated by the formula:

$$ATT1 = \begin{cases} 128 + 1024 \times 10^{A/20 \text{ dB}} & ;A > 18, 1 \text{ dB} \\ 128 \times 10^{A/20 \text{ dB}} & ;A < 18, 1 \text{ dB} \end{cases}$$

Detailed Register Description

16_h CNGCTL Calling Tone Control

15

0

EN	0	0	0	0	0	0	0	0	0	0	0	I1
----	---	---	---	---	---	---	---	---	---	---	---	----

Reset Value

0	0	0	0	0	0	0	0	0	0	0	0	0
---	---	---	---	---	---	---	---	---	---	---	---	---

EN Enable

0: CNG unit disabled

1: CNG unit enabled

I1 Input Selection for Calling Tone Detector

Detailed Register Description

17_h CNGBT CNG Burst Time

15	0
0	TIME

TIME Minimum Time for Calling Tone

In order to obtain the parameter TIME for a minimum time t the following formula can be used:

$$TIME = t/0.125 \text{ ms}$$

Detailed Register Description

18_h CNGLEV CNG Minimal Signal Level

15		0
0	0	MIN

MIN Minimum Signal Level for Calling Tone

In order to obtain the parameter MIN for a minimum signal level L the following formula can be used:

$$MIN = 16384 \times 10^{L/20} \text{ dB}$$

Detailed Register Description

19_h CNGRES CNG Signal Resolution

15				0
1	1	1	1	RES

RES Signal Resolution

The parameter RES depends on the noise level *L* as follows:

$$RES = -4096 \times 10^{L/20 \text{ dB}}$$

Detailed Register Description

1A_h ATDCTL0 Alert Tone Detection 0

15

0

EN	0	0	I1	0	0	0	0	0	0	0	ATC
----	---	---	----	---	---	---	---	---	---	---	-----

Reset Value

0	0	0	0	0	0	0	0	0	0	0	- ¹⁾
---	---	---	---	---	---	---	---	---	---	---	-----------------

¹⁾ undefined

EN Enable alert tone detection

0: The alert tone detection is disabled

1: The alert tone detection is enabled

I1 Input signal selection

ATC Alert Tone Code

1	0	Description
0	0	no tone
0	1	2130
1	0	2750
1	1	2130/2750

Detailed Register Description

1B_h ATDCTL1 Alert Tone Detection 1

15

0

MD	0	0	DEV	0	0	0	0	MIN
----	---	---	-----	---	---	---	---	-----

MD Alert tone detection mode

0: Only dual tones will be detected

1: Either dual or single tones will be detected

DEV Maximum frequency deviation for alert tone

0: 0.5%

1: 1.1%

MIN Minimum level of alert tone signal

For a minimum signal level *min* the parameter MIN is given by the following formula:

$$MIN = 2560 \times 10^{\min/20 \text{ dB}}$$

Detailed Register Description

1C_h CIDCTL0 Caller ID Control 0

15

0

EN	0	0	I1	DATA
----	---	---	----	------

Reset Value

0	0	0	0	0
---	---	---	---	---

EN CID Enable

0: Disabled

1: Enabled

I1 Input signal selection

DATA Last received data byte

Detailed Register Description

1D_h CIDCTL1 Caller ID Control 1

15

0

NMB	NMSS	MIN
-----	------	-----

NMB Minimum Number of Mark Bits

15	14	13	12	11	10	Description
0	0	0	0	0	0	0
0	0	0			1	10
...
1	1	1	1	1	1	630

NMSS Minimum Number of Mark/Space Sequences

9	8	7	6	5	Description
0	0	0	0	0	1
0	0	0	0	1	11
...	
1	1	1	1	1	311

MIN Minimum Signal Level for CID Decoder

For a minimum signal level *min* the parameter MIN is given by the following formula:

$$MIN = 640 \times 10^{\min/20 \text{ dB}}$$

Detailed Register Description

20_h CPTCTL Call Progress Tone Control

15

0

EN	MD	0	0	0	0	0	0	0	0	0	I1
----	----	---	---	---	---	---	---	---	---	---	----

Reset Value

0	0	0	0	0	0	0	0	0	0	0	0
---	---	---	---	---	---	---	---	---	---	---	---

EN CPT Detector Enable

0: Disabled

1: Enabled

MD CPT Mode

0: raw

1: cooked

I1 Input signal selection

Detailed Register Description

21_h CPTTR Call Progress Tone Thresholds

15

0

NUM	0	SN	MIN
-----	---	----	-----

NUM Number of Cycles

15	14	13	cooked mode	raw mode
0	0	0	reserved	0
0	0	1	2	reserved
...	reserved
1	1	1	8	reserved

SN Minimal Signal-to-Noise Ratio

11	10	9	8	Description
1	1	1	1	9 dB
1	0	0	0	12 dB
0	1	0	0	15 dB
0	0	1	0	18 dB
0	0	0	0	22 dB

MIN Minimum Signal Level for CPT Detector

Value	Description
89 _h	-40 dB
85 _h	-42 dB
80 _h	-44 dB
9A _h	-46 dB
95 _h	-48 dB
90 _h	-50 dB

Detailed Register Description

22_h CPTMN CPT Minimum Times

15

0

MINB	MING
------	------

MINB Minimum Time for CPT Burst

The parameter MINB for a minimal burst time TB_{min} can be calculated by the following formula:

$$MINB = \frac{TB_{min} - 32 \text{ ms}}{4}$$

MING Minimum Time for CPT Gap

The parameter MING for a minimal burst time TG_{min} can be calculated by the following formula:

$$MING = \frac{TG_{min} - 32 \text{ ms}}{4}$$

Detailed Register Description

23_h CPTMX CPT Maximum Times

15	0
MAXB	MAXG

MAXB Maximum Time for CPT Burst

The parameter MAXB for a maximal burst time of TB_{max} can be calculated by the following formula:

$$MAXB = \frac{TB_{max} - TB_{min}}{8}$$

MAXG Maximum Time for CPT Gap

The parameter MAXG for a maximal burst time of TG_{max} can be calculated by the following formula:

$$MAXG = \frac{TG_{max} - TG_{min}}{8}$$

Detailed Register Description

24_h CPTDT CPT Delta Times

15	0
DIFB	DIFG

DIFB Maximum Time Difference between consecutive Bursts

The parameter DIFB for a maximal difference of t ms of two burst durations can be calculated by the following formula:

$$\text{DIFB} = \frac{t}{2 \text{ ms}}$$

DIFG Maximum Time Difference between consecutive Gaps

The parameter DIFG for a maximal difference of t ms of two gap durations can be calculated by the following formula:

$$\text{DIFG} = \frac{t}{2 \text{ ms}}$$

Detailed Register Description

25_h LECCTL Line Echo Cancellation Control

15								0
EN	MD	0	0	0	0	I1	I2	
Reset Value								
0	0	0	0	0	0	0	0	

EN Enable

0: Disabled

1: Enabled

MD Mode

0: Normal

1: Extended

I1 Input signal selection for I₁

I2 Input signal selection for I₂

Detailed Register Description

26_h LECLEV Minimal Signal Level for Line Echo Cancellation

15	0
0	MIN

MIN

The parameter MIN for a minimal signal level L (dB) can be calculated by the following formula:

$$MIN = \frac{512 \times (96.3 + L)}{5 \times \log 2}$$

Detailed Register Description**27_h LECATT Externally Provided Attenuation**

15	0
0	ATT

ATT

The parameter ATT for an externally provided attenuation A (dB) can be calculated by the following formula:

$$ATT = \frac{512 \times A}{5 \times \log 2}$$

Detailed Register Description

28_h LECMGN Margin for Double Talk Detection

15	0
0	MGN

MGN

The parameter MGN for a margin of L (dB) can be calculated by the following formula:

$$MGN = \frac{512 \times L}{5 \times \log 2}$$

Detailed Register Description

29_h DDCTL DTMF Detector Control

15

0

EN	0	0	I1			0	0	0	DTC
----	---	---	----	--	--	---	---	---	-----

Reset Value

0	0	0	0			0	0	0	_1)
---	---	---	---	--	--	---	---	---	-----

¹⁾ undefined

EN Enable DTMF tone detection

0: The DTMF detection is disabled

1: The DTMF detection is enabled

I1 Input signal selection

DTC DTMF Tone Code

4	3	2	1	0	Frequency	Digit
1	0	0	0	0	941 / 1633	D
1	0	0	0	1	697 / 1209	1
1	0	0	1	0	697 / 1336	2
1	0	0	1	1	697 / 1477	3
1	0	1	0	0	770 / 1209	4
1	0	1	0	1	770 / 1336	5
1	0	1	1	0	770 / 1477	6
1	0	1	1	1	852 / 1209	7
1	1	0	0	0	852 / 1336	8
1	1	0	0	1	852 / 1477	9
1	1	0	1	0	941 / 1336	0
1	1	0	1	1	941 / 1209	*
1	1	1	0	0	941 / 1477	#
1	1	1	0	1	697 / 1633	A
1	1	1	1	0	770 / 1633	B
1	1	1	1	1	852 / 1633	C

Detailed Register Description

2A_h DDTW DTMF Detector Signal Twist

15

0

0	TWIST
---	-------

TWIST Signal twist for DTMF tone

In order to obtain a minimal signal twist T the parameter TWIST can be calculated by the following formula:

$$\text{TWIST} = 32768 \times 10^{(0.5 \text{ dB} - T) / 10 \text{ dB}}$$

Note: TWIST must be in the range [4096,20480]

Detailed Register Description

2B_h DDLEV DTMF Detector Minimum Signal Level

15

0

1	1	1	1	1	1	1	1	1	1	1	MIN
---	---	---	---	---	---	---	---	---	---	---	-----

MIN Minimum Signal Level

5	4	3	2	1	0	Description
0	0	1	1	1	0	-50 dB
0	0	1	1	1	1	-49 dB
...
1	0	0	0	0	1	-31 dB
1	0	0	0	1	0	-30 dB

Note: Values outside the given range are reserved and must not be used.

Detailed Register Description

2E_h FCFCTL Equalizer Control

15

0

EN	0	ADR	0	0	0	1
----	---	-----	---	---	---	---

Reset Value

0	0	0	0	0	0	0
---	---	---	---	---	---	---

EN Enable equalizer

0: The equalizer is disabled

1: The equalizer is enabled

ADR Coefficient address

13	12	11	10	9	8	Coefficient
0	0	0	0	0	0	A1
0	0	0	0	0	1	A2
0	0	0	0	1	0	A3
0	0	0	0	1	1	A4
0	0	0	1	0	0	A5
0	0	0	1	0	1	A6
0	0	0	1	1	0	A7
0	0	0	1	1	1	A8
0	0	1	0	0	0	A9
0	0	1	0	0	1	B2
0	0	1	0	1	0	B3
0	0	1	0	1	1	B4
0	0	1	1	0	0	B5
0	0	1	1	0	1	B6
0	0	1	1	1	0	B7
0	0	1	1	1	1	B8
0	1	0	0	0	0	B9
0	1	0	0	0	1	C1
0	1	0	0	1	0	D1
0	1	0	0	1	1	D2
0	1	0	1	0	0	D3
0	1	0	1	0	1	D4
0	1	0	1	1	0	D5

Detailed Register Description

13	12	11	10	9	8	Coefficient
0	1	0	1	1	1	D6
0	1	1	0	0	0	D7
0	1	1	0	0	1	D8
0	1	1	0	1	0	D9
0	1	1	0	1	1	D10
0	1	1	1	0	0	D11
0	1	1	1	0	1	D12
0	1	1	1	1	0	D13
0	1	1	1	1	1	D14
1	0	0	0	0	0	D15
1	0	0	0	0	1	D16
1	0	0	0	1	0	D17
1	0	0	0	1	1	C2

I1 Input signal selection

Detailed Register Description

2F_h FCFCOF Equalizer Coefficient Data

15	0
V	

V Coefficient value

For the coefficient A₁-A₉, B₂-B₉ and D₁-D₁₇ the following formula can be used to calculate V for a coefficient c:

$$V = 32768 \times c \quad ; -1 \leq c < 1$$

For the coefficients C₁ and C₂ the following formula can be used to calculate V for a coefficient c:

$$V = 128 \times c \quad ; 1 \leq c < 256$$

Detailed Register Description

30_h SCCTL Speech Coder Control

15								0
EN	HQ	VC	0	0	0	I1		I2
Reset Value								
0	0	0	0	0	0	0		0

EN Enable

- 0: Disabled
- 1: Enabled

HQ High Quality Mode

- 0: Long Play Mode
- 1: High Quality Mode

VC Voice Controlled Start of Recording

- 0: Disabled
- 1: Enabled

I1 Input signal selection (first input)

I2 Input signal selection (second input)

Detailed Register Description

31_h SCCT2 Speech Coder Control 2

15	0
TIME	MIN

TIME

The parameter TIME for a time t ([ms]) can be calculated by the following formula:

$$\text{TIME} = \frac{t}{32}$$

MIN

The parameter MIN for a signal level L ([dB]) can be calculated by the following formula:

$$\text{MIN} = 16384 \times 10^{\frac{L}{20}}$$

Detailed Register Description

32_h SCCT3 Speech Coder Control 3

15										0
0		LP		0	0	0	0	0	0	0

LP

The parameter LP for a time constant of t ([ms]) can be calculated by the following formula:

$$LP = \frac{256}{t}$$

Detailed Register Description

34_h SDCTL Speech Decoder Control

15

0

EN	0	0	0	0	0	0	0	0	0	0	0	0	0	SPEED
----	---	---	---	---	---	---	---	---	---	---	---	---	---	-------

Reset Value

0	0	0	0	0	0	0	0	0	0	0	0	0	0	0
---	---	---	---	---	---	---	---	---	---	---	---	---	---	---

EN Enable

0: Disabled

1: Enabled

SPEED Playback Speed

1	0	Description
0	0	normal speed
0	1	0.5 times normal speed
1	0	1.5 times normal speed
1	1	2.0 times normal speed

Detailed Register Description

38_h AGCCTL AGC Control

15								0	
EN	0	0	0	0	0	I1		I2	
Reset Value									
0	0	0	0	0	0	0		0	

EN Enable

0: Disabled

1: Enabled

I1 Input signal selection for I₁

I2 Input signal selection for I₂

Detailed Register Description

39_h AGCATT Automatic Gain Control Attenuation

15	0
ATT	
Reset Value	
0 (-100 dB)	

ATT

The parameter ATT for an attenuation A ([dB]) can be calculated by the following formula:

$$ATT = 32768 \times 10^{\frac{A}{20}}$$

Detailed Register Description

3A_h AGC1 Automatic Gain Control 1

15

0

COM	AG_INIT
-----	---------

COM

The parameter COM for a signal level L ([dB]) can be calculated by the following formula:

$$COM = \begin{cases} 128 + 10^{\frac{L + 66,22}{20}} & ;L < -42,14 \text{ dB} \\ 10^{\frac{L + 42,14}{20}} & ;L > -42,14 \text{ dB} \end{cases}$$

AG_INIT

In order to obtain an initial gain G ([db]) the parameter AG_INIT can be calculated by the following formula:

$$AG_INIT = \begin{cases} 128 + 10^{\frac{G + 18,06}{20}} & ;G < 6,02 \text{ dB} \\ 10^{\frac{G - 6,02}{20}} & ;G > 6,02 \text{ dB} \end{cases}$$

Detailed Register Description

3B_h AGC2 Automatic Gain Control 2

15	0
SPEEDL	SPEEDH

SPEEDL

The parameter SPEEDL for a multiplication factor M is given by the following formula:

$$\text{SPEEDL} = \frac{M}{8192}$$

SPEEDH

The parameter SPEEDH for a multiplication factor M is given by the following formula:

$$\text{SPEEDH} = \frac{M}{256}$$

Detailed Register Description

3C_h AGC3 Automatic Gain Control 3

15	0
MIN	MAX

MIN

The parameter MIN for a gain G ([dB]) can be calculated by the following formula:

$$\text{MIN} = \begin{cases} 128 + 10^{\frac{G + 18,06}{20}} & ;G < 6,02 \text{ dB} \\ 10^{\frac{G - 6,02}{20}} & ;G > 6,02 \text{ dB} \end{cases}$$

MAX

The parameter MAX for an attenuation A ([dB]) can be calculated by the following formula:

$$\text{MAX} = 10^{\frac{A + 42,14}{20}}$$

Detailed Register Description

3D_h AGC4 Automatic Gain Control 4

15	0
DEC	LIM

DEC

The parameter DEC for a time constant t ([1/ms]) is given by the following formula:

$$\text{DEC} = \frac{256}{t}$$

LIM

The parameter LIM for a signal level L ([dB]) can be calculated by the following formula:

$$\text{LIM} = \begin{cases} 128 + 10^{\frac{L + 90,3}{20}} & ;L < 66,22 \text{ dB} \\ 10^{\frac{L + 66,22}{20}} & ;L > 66,22 \text{ dB} \end{cases}$$

Detailed Register Description

3E_h AGC5 Automatic Gain Control 5

15									0
0	0	0	0	0	0	0	0	1	LP

LP

The parameter LP for a time constant t ([1/ms]) is given by the following formula:

$$LP = \frac{16}{t}$$

Detailed Register Description

40_h FCTL File Control

15 **0**

0	MD	MS	TS	0	0	0	0	FNO
---	----	----	----	---	---	---	---	-----

Reset Value

0	0	0	0	0	0	0	0	0
---	---	---	---	---	---	---	---	---

MD Mode

- 0: Audio Mode
- 1: Binary Mode

MS Memory Space

- 0: R/W Memory
- 1: Voice Prompt Directory

TS Time Stamp

- 0: no update of RTC1/RTC2 entry of file descriptor
- 1: RTC1/RTC2 entries are updated by content of RTC1/RTC2 registers.

FNO File Number

Detailed Register Description

41_h FCMD File Command

15 **0**

0	IN	RD	0	0	0	0	0	0	ABT	EIE	0	CMD
---	----	----	---	---	---	---	---	---	-----	-----	---	-----

Reset Value

0	0	0	0	0	0	0	0	0	0	0	0	0
---	---	---	---	---	---	---	---	---	---	---	---	---

IN Initialize

- 0: no
- 1: yes (if CMD=1111)

RD Remap Directory

- 0: no
- 1: yes

ABT Abort Command

- 0: no
- 1: abort recompress

EIE Enable Immediate Execution

- 0: disabled (default, always possible)
- 1: enabled (restricted to certain commands and operating modes)

CMD File Command

4	3	2	1	0	Description
0	0	0	0	0	Open File
0	0	0	0	1	Activate
0	0	0	1	0	Seek
0	0	0	1	1	Cut File
0	0	1	0	0	Read Data
0	0	1	0	1	Write Data
0	0	1	1	0	Memory Status
0	0	1	1	1	Recompress file
0	1	0	0	0	Read File Descriptor - User
0	1	0	0	1	Write File Descriptor - User

Detailed Register Description

4	3	2	1	0	Description
0	1	0	1	0	Read File Descriptor - RTC1
0	1	0	1	1	Read File Descriptor - RTC2
0	1	1	0	0	Read File Descriptor - LEN
0	1	1	0	1	Garbage Collection
0	1	1	1	0	Open Next Free File
0	1	1	1	1	Initialize
1	0	0	0	0	DMA Read
1	0	0	0	1	DMA Write
1	0	0	1	0	Erase Block
1	0	0	1	1	Set Address
1	0	1	-	-	reserved
1	1	0	-	-	reserved
1	1	1	-	-	reserved

Detailed Register Description

42_h FDATA File Data

15		0
FREE		
Reset Value		
0		

The FDATA register contains the following information after a memory status command:

FREE Free Blocks

Number of blocks (1 kByte) currently usable for recording.

Detailed Register Description

43_h FPTR File Pointer

15

0

File Pointer					
0	0	0	0	0	Phrase selector

Reset Value

0

Detailed Register Description

47h SPSCTL SPS Control

15

0

POS	0	0	0	0	0	0	0	0	MODE	SP1	SP0
-----	---	---	---	---	---	---	---	---	------	-----	-----

Reset Value

0	0	0	0	0	0	0	0	0	0	- ¹⁾	- ¹⁾
---	---	---	---	---	---	---	---	---	---	-----------------	-----------------

¹⁾ undefined

POS Position of Status Register Window

15	14	13	12	SPS ₀	SPS ₁
0	0	0	0	Bit 0	Bit 1
0	0	0	1	Bit 1	Bit 2
...
1	1	1	0	Bit 14	Bit 15

MODE Mode of SPS Interface

4	3	2	Description
0	0	0	Disabled (SPS ₀ and SPS ₁ zero)
0	0	1	Output of SP1 and SP0
1	0	0	Output of speakerphone state
1	0	1	Expanded address output
1	1	0	Output of STATUS register

SP1 Direct Control for SPS₁

0: SPS₁ set to 0

1: SPS₁ set to 1

SP0 Direct Control for SPS₀

0: SPS₀ set to 0

1: SPS₀ set to 1

Note: If mode 1 has been selected prior to power-down, both mode 1 and the values of SP1 and SP0 are retained during power-down and wake-up. Other modes are reset to 0 during power down.

Detailed Register Description

48_h RTC1 Real Time Clock 1

15

0

0	0	0	0	MIN	SEC
---	---	---	---	-----	-----

Reset Value

0	0	0	0	0	0
---	---	---	---	---	---

MIN Minutes

Number of minutes elapsed in the current hour (0-59).

SEC Seconds

Number of seconds elapsed in the current minute (0-59).

Detailed Register Description

49_h RTC2 Real Time Clock 2

15	0
DAY	HR
Reset Value	
0	0

DAY Days

Number of days elapsed since last reset (0-2047).

HR Hours

Number of hours elapsed in the current day (0-23).

Detailed Register Description

4A_h DOUT0 Data Out (Timeslot 0)

15				0
0	0	0	0	DATA
Reset Value				
0	0	0	0	0

DATA Output Data

Output data for pins MA₀-MA₁₁ while MA₁₂=1 (only if HWCONFIG1:APP=10).

Note: This register cannot be read.

Detailed Register Description

4B_n DOUT1 Data Out (Timeslot 1)

15				0
0	0	0	0	DATA
Reset Value				
0	0	0	0	0

DATA Output Data

Output data for pins MA₀-MA₁₁ while MA₁₃=1 (only if HWCONFIG1:APP=10).

Note: This register cannot be read.

Detailed Register Description

4C_h DOUT2 Data Out (Timeslot 2)

15				0
0	0	0	0	DATA
Reset Value				
0	0	0	0	0

DATA Output Data

Output data for pins MA₀-MA₁₁ while MA₁₄=1 (only if HWCONFIG1:APP=10).

Note: This register cannot be read.

Detailed Register Description

4D_h DOUT3 Data Out (Timeslot 3 or Static Mode)

15	0
DATA	
Reset Value	
0	

DATA Output Data

Output data for pins MA₀-MA₁₁ while MA₁₅=1 (only if HWCONFIG1:APP=10).

Output data for pins MA₀-MA₁₅ (only if HWCONFIG1:APP=01)

Note: This register cannot be read.

Detailed Register Description

4E_h DIN Data In (Timeslot 3 or Static Mode)

15

0



DATA Input Data

Input data for pins MA₀-MA₁₁ at falling edge of MA₁₂ (only if HWCONFIG1:APP=10).

Input data for pins MA₀-MA₁₅ (only if HWCONFIG1:APP=01)

Detailed Register Description

4F_h DDIR Data Direction (Timeslot 3 or Static Mode)

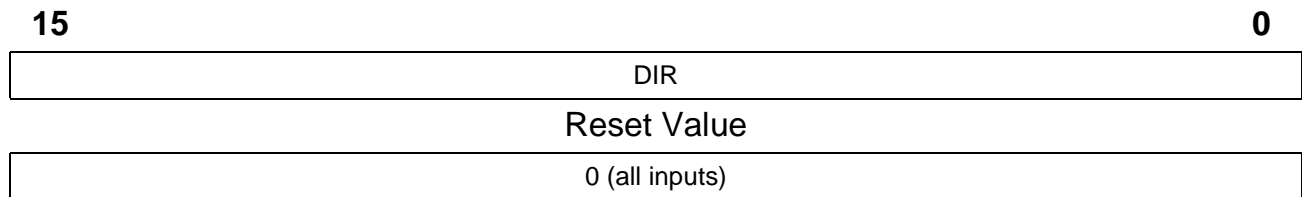

DIR Port Direction

Port direction during MA₁₂=1 or in static mode.

0: input

1: output

Note: This register cannot be read.

Detailed Register Description

60_h SCTL Speakerphone Control

15

0

ENS	ENC	0	0	0	0	0	0	MD	SDR	SDX	0	0	AGR	AGX	0
-----	-----	---	---	---	---	---	---	----	-----	-----	---	---	-----	-----	---

Reset Value

0	0	0	0	0	0	0	0	0	0	0	0	0	0	0	0
---	---	---	---	---	---	---	---	---	---	---	---	---	---	---	---

ENS Enable Echo Suppression

- 0: The echo suppression unit is disabled
- 1: The echo suppression unit is enabled

ENC Enable Echo Cancellation

- 0: The echo cancellation unit is disabled
- 1: The echo cancellation unit is enabled

MD Mode

- 0: Speakerphone mode
- 1: Loudhearing mode

SDR Signal Source of SDR

- 0: after AGCR
- 1: before AGCR

SDX Signal Source of SDX

- 0: after AGCX
- 1: before AGCX

AGR AGCR Enable

- 0: AGCR disabled
- 1: AGCR enabled

AGX AGCX Enable

- 0: AGCX disabled
- 1: AGCX enabled

Detailed Register Description

62_h SSRC1 Speakerphone Source 1

15								0	
0	0	0	0	0	0	I1		I2	
Reset Value									
0	0	0	0	0	0	0		0	

I1 Input Signal Selection (Acoustic Source 1)

I2 Input Signal Selection (Acoustic Source 2)

Detailed Register Description

63_h SSRC2 Speakerphone Source 2

15 **0**

0	0	0	0	0	0	13	14
---	---	---	---	---	---	----	----

Reset Value

0	0	0	0	0	0	0	0
---	---	---	---	---	---	---	---

13 Input Signal Selection (Line Source 1)

14 Input Signal Selection (Line Source 2)

Detailed Register Description

64_h SSDX1 Speech Detector (Transmit) 1

15			0
0	LP2L	0	LIM

LP2L

The parameter LP2L for a saturation level L (dB) can be calculated by the following formula:

$$LP2L = \frac{2 \times L}{5 \times \log 2}$$

LIM

The parameter LIM for a minimum signal level L (dB, relative to PCM max. value) can be calculated by the following formula:

$$LIM = \frac{2 \times (96.3 + L)}{5 \times \log 2}$$

Detailed Register Description

65_h SSDX2 Speech Detector (Transmit) 2

15

0

LP1	0	OFF
-----	---	-----

LP1

The parameter LP1 for a time t (ms) can be calculated by the following formula:

$$LP1 = \begin{cases} 64/t & ;0.5 < t < 64 \\ 128 + 2048/t & ;16.2 < t < 2048 \end{cases}$$

OFF

The parameter OFF for a level offset of O (dB) can be calculated by the following formula:

$$OFF = \frac{2 \times O}{5 \times \log 2}$$

Detailed Register Description

66_h SSDX3 Speech Detector (Transmit) 3

15	0
PDN	LP2N

PDN

The parameter PDN for a time t (ms) can be calculated by the following formula:

$$PDN = \begin{cases} 64/t & ;0.5 < t < 64 \\ 128 + 2048/t & ;16.2 < t < 2048 \end{cases}$$

LP2N

The parameter LP2N for a time t (ms) can be calculated by the following formula:

$$LP2N = \begin{cases} 64/t & ;0.5 < t < 64 \\ 128 + 2048/t & ;16.2 < t < 2048 \end{cases}$$

Detailed Register Description

67_h SSDX4 Speech Detector (Transmit) 4

15	0	0
PDS	0	LP2S

PDS

The parameter PDS for a time t (ms) can be calculated by the following formula:

$$PDS = \begin{cases} 64/t & ;0.5 < t < 64 \\ 128 + 2048/t & ;16.2 < t < 2048 \end{cases}$$

LP2S

The parameter LP2S for a time t (ms) can be calculated by the following formula:

$$LP2S = \frac{262144}{t}$$

Detailed Register Description

68_h SDDR1 Speech Detector (Receive) 1

15		0
0	LP2L	LIM

LP2L

The parameter LP2L for a saturation level L (dB) can be calculated by the following formula:

$$LP2L = \frac{2 \times L}{5 \times \log 2}$$

LIM

The parameter LIM for a minimum signal level L (dB, relative to PCM max. value) can be calculated by the following formula:

$$LIM = \frac{2 \times (96.3 + L)}{5 \times \log 2}$$

Detailed Register Description

69_h SSSDR2 Speech Detector (Receive) 2

15

0

LP1	0	OFF
-----	---	-----

LP1

The parameter LP1 for a time t (ms) can be calculated by the following formula:

$$LP1 = \begin{cases} 64/t & ;0.5 < t < 64 \\ 128 + 2048/t & ;16.2 < t < 2048 \end{cases}$$

OFF

The parameter OFF for a level offset of O (dB) can be calculated by the following formula:

$$OFF = \frac{2 \times O}{5 \times \log 2}$$

Detailed Register Description

6A_h SSSDR3 Speech Detector (Receive) 3

15	0
PDN	LP2N

PDN

The parameter PDN for a time t (ms) can be calculated by the following formula:

$$PDN = \begin{cases} 64/t & ;0.5 < t < 64 \\ 128 + 2048/t & ;16.2 < t < 2048 \end{cases}$$

LP2N

The parameter LP2N for a time t (ms) can be calculated by the following formula:

$$LP2N = \begin{cases} 64/t & ;0.5 < t < 64 \\ 128 + 2048/t & ;16.2 < t < 2048 \end{cases}$$

Detailed Register Description

6B_h SSSDR4 Speech Detector (Receive) 4

15

0

PDS	0	LP2S
-----	---	------

PDS

The parameter PDS for a time t (ms) can be calculated by the following formula:

$$PDS = \begin{cases} 64/t & ;0.5 < t < 64 \\ 128 + 2048/t & ;16.2 < t < 2048 \end{cases}$$

LP2S

The parameter LP2S for a time t (ms) can be calculated by the following formula:

$$LP2S = \frac{262144}{t}$$

Detailed Register Description

6C_h SSCAS1 Speech Comparator (Acoustic Side) 1

15	0
G	ET

G

The parameter G for a gain A (dB) can be calculated by the following formula:

$$G = \frac{2 \times A}{5 \times \log 2}$$

Note: The parameter G is interpreted in two's complement.

ET

The parameter ET for a time t (ms) can be calculated by the following formula:

$$ET = \frac{t}{4}$$

Detailed Register Description

6D_h SSCAS2 Speech Comparator (Acoustic Side) 2

15	0
0	0
GDN	PDN

GDN

The parameter GDN for a gain G (dB) can be calculated by the following formula:

$$\text{GDN} = \frac{4 \times G}{5 \times \log 2}$$

PDN

The parameter PDN for a decay rate R (ms/dB) can be calculated by the following formula:

$$\text{PDN} = \frac{64 \times R}{5 \times \log 2}$$

Detailed Register Description

6E_h SSCAS3 Speech Comparator (Acoustic Side) 3

15		0
0	GDS	PDS

GDS

The parameter GDS for a gain G (dB) can be calculated by the following formula:

$$\text{GDS} = \frac{4 \times G}{5 \times \log 2}$$

PDS

The parameter PDS for a decay rate R (ms/dB) can be calculated by the following formula:

$$\text{PDS} = \frac{64 \times R}{5 \times \log 2}$$

Detailed Register Description

6F_h SSCLS1 Speech Comparator (Line Side) 1

15	0
G	ET

G

The parameter G for a gain A (dB) can be calculated by the following formula:

$$G = \frac{2 \times A}{5 \times \log 2}$$

Note: The parameter G is interpreted in two's complement.

ET

The parameter ET for a time t (ms) can be calculated by the following formula:

$$ET = \frac{t}{4}$$

Detailed Register Description

70_h SSCLS2 Speech Comparator (Line Side) 2

15	0
0	0
GDN	PDN

GDN

The parameter GDN for a gain G (dB) can be calculated by the following formula:

$$\text{GDN} = \frac{4 \times G}{5 \times \log 2}$$

PDN

The parameter PDN for a decay rate R (ms/dB) can be calculated by the following formula:

$$\text{PDN} = \frac{64 \times R}{5 \times \log 2}$$

Detailed Register Description

71_h SSCLS3 Speech Comparator (Line Side) 3

15	0
0	0
GDS	PDS

GDS

The parameter GDS for a gain G (dB) can be calculated by the following formula:

$$\text{GDS} = \frac{4 \times G}{5 \times \log 2}$$

PDS

The parameter PDS for a decay rate R (ms/dB) can be calculated by the following formula:

$$\text{PDS} = \frac{64 \times R}{5 \times \log 2}$$

Detailed Register Description

72_h SATT1 Attenuation Unit 1

15	0
0	0
ATT	SW

ATT

The parameter ATT for an attenuation A (dB) can be calculated by the following formula:

$$ATT = \frac{2 \times A}{5 \times \log 2}$$

SW

The parameter SW for a switching rate R (ms/dB) can be calculated by the following formula:

$$SW = \begin{cases} 128 + \frac{1}{5 \times \log 2 \times SW} & ; 0.0053 < SW < 0.66 \\ \frac{16}{5 \times \log 2 \times SW} & ; 0.66 < SW < 0.63 \end{cases}$$

Detailed Register Description

73_h SATT2 Attenuation Unit 2

15	0
TW	DS

TW

The parameter TW for a time t (ms) can be calculated by the following formula:

$$TW = \frac{t}{16}$$

DS

The parameter DS for a decay rate R (ms/dB) can be calculated by the following formula:

$$DS = \frac{5 \times \log_2 \times R - 1}{4}$$

Detailed Register Description

74_h SAGX1 Automatic Gain Control (Transmit) 1

15	0	0
AG_INIT	0	COM

AG_INIT

The parameter AG_INIT for a gain G (dB) can be calculated by the following formula:

$$AG_INIT = \frac{-2 \times G}{5 \times \log 2}$$

This parameter is interpreted in two's complement.

COM

The threshold COM for a level L (dB) can be calculated by the following formula:

$$COM = \frac{2 \times (96.3 + L)}{5 \times \log 2}$$

Detailed Register Description

75_h SAGX2 Automatic Gain Control (Transmit) 2

15	0
0	SPEEDH

AG_ATT

The parameter AG_ATT for a gain G (dB) can be calculated by the following formula:

$$AG_ATT = \frac{-2 \times G}{5 \times \log 2}$$

SPEEDH

The parameter SPEEDH for the regulation speed R (ms/dB) can be calculated by the following formula:

$$SPEEDH = \frac{4096}{D \times R}$$

The variable D denotes the aberration (dB).

Detailed Register Description

76_h SAGX3 Automatic Gain Control (Transmit) 3

15	0
AG_GAIN	SPEEDL

AG_GAIN

The parameter AG_GAIN for a gain G (dB) can be calculated by the following formula:

$$\text{AG_GAIN} = \frac{-2 \times G}{5 \times \log 2}$$

SPEEDL

The parameter COM for a gain G (dB) can be calculated by the following formula:

$$\text{COM} = \frac{2 \times (96.3 + G)}{5 \times \log 2}$$

The variable D denotes the aberration (dB).

Detailed Register Description

77_h SAGX4 Automatic Gain Control (Transmit) 4

15			0
0	NOIS	0	LPA

NOIS

The parameter NOIS for a threshold level L (dB) can be calculated by the following formula:

$$\text{COM} = \frac{2 \times (96.3 + L)}{5 \times \log 2}$$

LPA

The parameter LPA for a low pass time constant T (mS) can be calculated by the following formula:

$$\text{LPA} = \frac{16}{T}$$

Detailed Register Description

78_h **SAGX5** **Automatic Gain Control (Transmit) 5**

15	0
AG_CUR	0 0 0 0 0 0 0 0

AG_CUR

The current gain G of the AGC can be derived from the parameter Parameter AG_CUR by the following formula:

$$G = \frac{-5 \times \log_2 \times \text{AG_CUR}}{2}$$

AG_CUR is interpreted in two's complement.

Detailed Register Description

79_h SAGR1 Automatic Gain Control (Receive) 1

15	0	0
AG_INIT	0	COM

AG_INIT

The parameter AG_INIT for a gain G (dB) can be calculated by the following formula:

$$AG_INIT = \frac{-2 \times G}{5 \times \log 2}$$

This parameter is interpreted in two's complement.

COM

The parameter COM for a threshold L (dB) can be calculated by the following formula:

$$COM = \frac{2 \times (96.3 + L)}{5 \times \log 2}$$

Detailed Register Description

7A_h SAGR2 Automatic Gain Control (Receive) 2

15	0
0	SPEEDH

AG_ATT

The parameter AG_ATT for a gain G (dB) can be calculated by the following formula:

$$AG_ATT = \frac{-2 \times G}{5 \times \log 2}$$

SPEEDH

The parameter SPEEDH for the regulation speed R (ms/dB) can be calculated by the following formula:

$$SPEEDH = \frac{4096}{D \times R}$$

The variable D denotes the aberration (dB).

Detailed Register Description

7B_h SAGR3 Automatic Gain Control (Receive) 3

15

0

AG_GAIN	SPEEDL
---------	--------

AG_GAIN

The parameter AG_GAIN for a gain G (dB) can be calculated by the following formula:

$$\text{AG_GAIN} = \frac{-2 \times G}{5 \times \log 2}$$

SPEEDL

The parameter SPEEDL for the regulation speed R (ms/dB) can be calculated by the following formula:

$$\text{SPEEDL} = \frac{4096}{D \times R}$$

The variable D denotes the aberration (dB).

Detailed Register Description

7C_h SAGR4 Automatic Gain Control (Receive) 4

15			0
0	NOIS	0	LPA

NOIS

The parameter NOIS for a threshold level L (dB) can be calculated by the following formula:

$$COM = \frac{2 \times (96.3 + L)}{5 \times \log 2}$$

LPA

The parameter LPA for a low pass time constant T (mS) can be calculated by the following formula:

$$LPA = \frac{16}{T}$$

Detailed Register Description

7D_h SAGR5 Automatic Gain Control (Receive) 5

15	0
AG_CUR	0 0 0 0 0 0 0 0

AG_CUR

The current gain G of the AGC can be derived from the parameter Parameter AG_CUR by the following formula:

$$G = \frac{-5 \times \log_2 \times \text{AG_CUR}}{2}$$

AG_CUR is interpreted in two's complement.

Detailed Register Description

7E_h SLGA Line Gain

15			0
0	LGAR	0	LGAX

LGAR

The parameter LGAR for a gain G (dB) is given by the following formula:

$$LGAR = 128 \times 10^{(G - 12)/20}$$

LGAX

The parameter LGAX for a gain G (dB) is given by the following formula:

$$LGAX = 128 \times 10^{(G - 12)/20}$$

Detailed Register Description**80_h SAELEN Acoustic Echo Cancellation Length****15****0**

0	0	0	0	0	0	0	LEN
---	---	---	---	---	---	---	-----

LEN

LEN denotes the number of FIR-taps used.

Detailed Register Description**81_h SAEATT Acoustic Echo Cancellation Double Talk Attenuation**

15	0
0	ATT

ATT

The parameter ATT for an attenuation A (dB) is given by the following formula:

$$ATT = \frac{512 \times A}{5 \times \log 2}$$

Detailed Register Description

82_h SAEGS Acoustic Echo Cancellation Global Scale

15													0
0	0	0	0	0	0	0	0	0	0	0	0	0	GS

GS

All coefficients of the FIR filter are scaled by a factor C. This factor is given by the following equation:

$$C = 2^{GS}$$

Detailed Register Description

83_h SAEPS1 Acoustic Echo Cancellation Partial Scale

15													0
0	0	0	0	0	0	0	0	0	0	0	0	0	PS

PS

The additional scaling coefficient AC is given by the following formula:

$$AC = 2^{PS}$$

Detailed Register Description

84_h SAEPS2 Acoustic Echo Cancellation First Block

15													0	
0	0	0	0	0	0	0	0	0	0	0	0	0	0	FB

FB

The parameter FB denotes the first block that is affected by the partial scaling coefficient. If the partial coefficient is one, FB is disregarded.

Electrical Characteristics

4 Electrical Characteristics

4.1 Absolute Maximum Ratings

Parameter	Symbol	Limit Values	Unit
Ambient temperature under bias	T_A	-20 to 85	°C
Storage temperature	T_{STG}	- 65 to 125	°C
Supply Voltage	V_{DD}	-0.5 to 4.2	V
Supply Voltage	V_{DDA}	-0.5 to 4.2	V
Supply Voltage	V_{DDP}	-0.5 to 6	V
Voltage of pin with respect to ground: XTAL ₁ , XTAL ₂	V_S	0 to V_{DDA}	V
Voltage on any pin with respect to ground	V_S	If $V_{DDP} < 3$ V: - 0.4 to $V_{DD} + 0.5$ If $V_{DDP} > 3$ V: - 0.4 to $V_{DDP} + 0.5$	V

ESD integrity (according MIL-Std. 883D, method 3015.7): 2 kV

Exception: The pins \overline{INT} , SDX, DU/DX, DD/DR, SPS₀, SPS₁ and MD₀-MD₇ are not protected against voltage stress >1 kV.

Note: Stresses above those listed here may cause permanent damage to the device. Exposure to absolute maximum ratings conditions for extended periods may affect device reliability.

4.2 DC Characteristics

$V_{DD}/V_{DDA} = 3.3 \text{ V} \pm 0.3 \text{ V}$; $V_{DDP} = 5 \text{ V} \pm 10\%$; $V_{SS}/V_{SSA} = 0 \text{ V}$; $T_A = 0 \text{ to } 70 \text{ °C}$

Parameter	Symbol	Limit Values			Unit	Test Condition
		min.	typ.	max.		
Input leakage current	I_{IL}	- 1.0		1.0	μA	$0 \text{ V} \leq V_{IN} \leq V_{DD}$
H-input level (except MA ₀ -MA ₁₅ , XTAL ₁ , OSC ₁)	V_{IH1}	2.0		$V_{DDP} + 0.3$	V	
H-input level (OSC ₁)	V_{IH2}	0.8 V_{DD}		$V_{DDA} + 0.3$	V	
H-input level (MA ₀ -MA ₁₅ , MCTL ¹⁾)	V_{IH3}	2.0		V_{DD}	V	
L-input level (except pins XTAL ₁ , OSC ₁)	V_{IL1}	- 0.3		0.8	V	

Electrical Characteristics

$V_{DD}/V_{DDA} = 3.3 \text{ V} \pm 0.3 \text{ V}$; $V_{DDP} = 5 \text{ V} \pm 10\%$; $V_{SS}/V_{SSA} = 0 \text{ V}$; $T_A = 0 \text{ to } 70 \text{ }^\circ\text{C}$

Parameter	Symbol	Limit Values			Unit	Test Condition
		min.	typ.	max.		
L-input level (OSC ₁)	V_{IL2}	- 0.3		0.2 V_{DDA}	V	
H-output level (except DU/DX, DD/DR, MA ₀ -MA ₁₅ , SPS ₀ , SPS ₁ , MD ₀ -MD ₇)	V_{OH1}	$V_{DD} - 0.45$			V	$I_O = 2 \text{ mA}$
H-output level (SPS ₀ , SPS ₁ , MD ₀ -MD ₇ , SDX, INT)	V_{OH2}	$V_{DD} - 0.6$			V	$I_O = 2 \text{ mA}$
H-output level (MA ₀ -MA ₁₅)	V_{OH3}	$V_{DD} - 0.45$			V	$I_O = 5 \text{ mA}$
H-output level (DU/DX, DD/DR)	V_{OH4}	$V_{DD} - 0.6$			V	$I_O = 7 \text{ mA}$
L-output level (except DU/DX, DD/DR, MA ₀ -MA ₁₅)	V_{OL1}			0.45	V	$I_O = - 2 \text{ mA}$
L-output level (MA ₀ -MA ₁₅) (address mode or APP output)	V_{OL2}			0.45	V	$I_O = - 5 \text{ mA}$
L-output current (MA ₀ -MA ₁₅) (after reset)	I_{LO}	50	150	240	μA	RST=1
H-output current (MCTL ¹⁾)	I_{HO}	25	65	120	μA	RST=1
L-output level (pins DU/DX, DD/DR)	V_{OL3}			0.45	V	$I_O = - 7 \text{ mA}$
Internal pullup current (FRDY)	I_{LI}	350	750	1300	μA	
Input capacitance	C_I			10	pF	
Output capacitance	C_O			15	pF	
V_{DD} supply current (power down, no refresh, no RTC)	I_{DDS1}		10	50	μA	
V_{DD} supply current (power down, refresh, RTC)	I_{DDS2}		20	70	μA	
V_{DD} supply current operating	I_{DDO}		55	70	mA	$V_{DD} = 3.3 \text{ V}$
V_{DDP} supply current	I_{DDP}		1	10	μA	

¹⁾ MCTL signals are ($\overline{W}/\overline{FWE}$, $\overline{VPRD}/\overline{FCLE}$, $\overline{RAS}/\overline{FOE}$, $\overline{CAS}_0/\overline{ALE}$, $\overline{CAS}_1/\overline{FCS}$)

Electrical Characteristics

4.3 AC Characteristics

Digital inputs are driven to 2.4 V for a logical “1” and to 0.45 V for a logical “0”. Timing measurements are made at 2.0 V for a logical “1” and 0.8 V for a logical “0”. The AC-testing input/output waveforms are shown below.

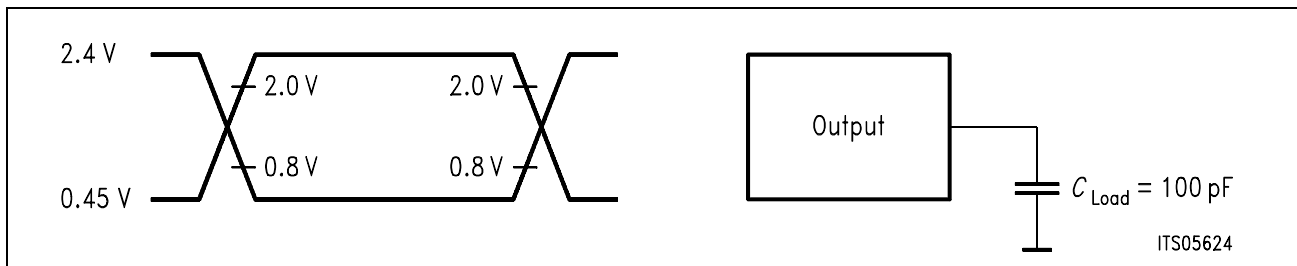

Figure 69 Input/Output Waveforms for AC-Tests

Electrical Characteristics

DTMF Detector

Parameter	Symbol	Limit Values			Unit	Test Condition
		min.	typ.	max.		
Frequency deviation accept		-1.5		1.5	%	
Frequency deviation reject		3.5		-3.5	%	
Acceptance level		-45		0	dB	rel. to max. PCM
Rejection level				-50	dB	rel. to max. PCM
Twist deviation accept		+/-2		+/-8	dB	programmable
Noise Tolerance				12	dB	
Signal duration accept		40			ms	
Signal duration reject				23	ms	
Gap duration accept		18			ms	

CPT Detector

Parameter	Symbol	Limit Values			Unit	Test Condition
		min.	typ.	max.		
Frequency acceptance range		300		640	Hz	
Frequency rejection range		800		200	Hz	
Acceptance level		-45		0	dB	rel. to max. PCM
Rejection level				-50	dB	rel. to max. PCM
Signal duration accept		50			ms	programmable
Signal duration reject				10	ms	

Caller ID Decoder

Parameter	Symbol	Limit Values			Unit	Test Condition
		min.	typ.	max.		
Frequency deviation accept		-2		2	%	
Acceptance level		-45		0	dB	rel. to max. PCM
Transmission rate		1188	1200	1212	baud	
Noise Tolerance				-12	dB	

Electrical Characteristics

Alert Tone Detector

Parameter	Symbol	Limit Values			Unit	Test Condition
		min.	typ.	max.		
Frequency deviation accept		-0.5		0.5	%	ATDCTL1:DEV=0
Frequency deviation accept		-1.1		1.1	%	ATDCTL1:DEV=1
Frequency deviation reject		3.5		-3.5	%	
Acceptance level		-40		0	dB	rel. to max. PCM
Rejection level				-5	dB	rel. to acceptance level
Twist deviation accept				+/-7	dB	
Noise Tolerance				20	dB	
Signal duration accept		75			ms	
Gap duration accept		40			ms	

CNG Detector

Parameter	Symbol	Limit Values			Unit	Test Condition
		min.	typ.	max.		
Frequency deviation accept		-40		40	Hz	
Frequency deviation reject		-50		50	Hz	
Acceptance level		-45		0	dB	SNR >10 dB
Acceptance level		-50		0	dB	SNR >15 dB
Rejection level		-3 dB			dB	rel. to CNGLEV:MIN
Signal duration reject				-1	%	rel. to CNGBT:TIME

Electrical Characteristics

Status Register Update Time

The individual bits of the STATUS register may change due to an event (like a recognized DTMF tone) or a command. The timing can be divided into four classes

Table 87 Status Register Update Timing

Class	Timing		Comment
	Min.	Max.	
I	0	0	Immediately after command has been issued
A	0	125 μ s ¹⁾	Command has been accepted
D	125 μ S	250 μ s	Deactivation time after command has been issued
E	-	-	Associated event has happened

¹⁾ one FSC period

With these definitions the timing of the individual bits in the STATUS register can be given as shown in table:

Bit	RDY	ABT	CIA	CD	CPT	CNG	SD	ERR	BSY	DTV	ATV
0->1	A	E	E	E	E	E	E	E	A ¹⁾	E	E
1->0	I	A	A,D	E,D	E,D	D	E,D	A	E	E,D	E,D

¹⁾ up to 30 ms if command is either SDCTL:EN=1 or SCCTL:EN=1

Electrical Characteristics

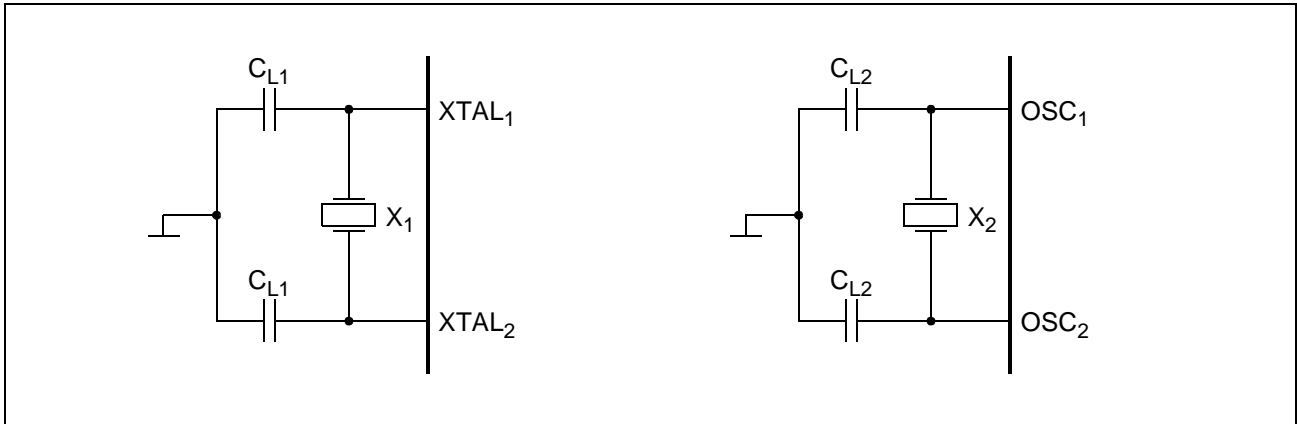

Figure 70 Oscillator Circuits

Recommended Values Oscillator Circuits	Value			Unit
	Min	Typ	Max	
Load CL ₁			40	pF
Static capacitance X ₁			5	pF
Motional capacitance X ₁			17	fF
Resonance resistor X ₁			60	Ω
Load CL ₂			30	pF
Static Capacitance X ₂		1.7		pF
Motional capacitance X ₂		3.5		fF
Resonance resistor X ₂		18	40	kΩ
Frequency deviation			100	ppm

Electrical Characteristics

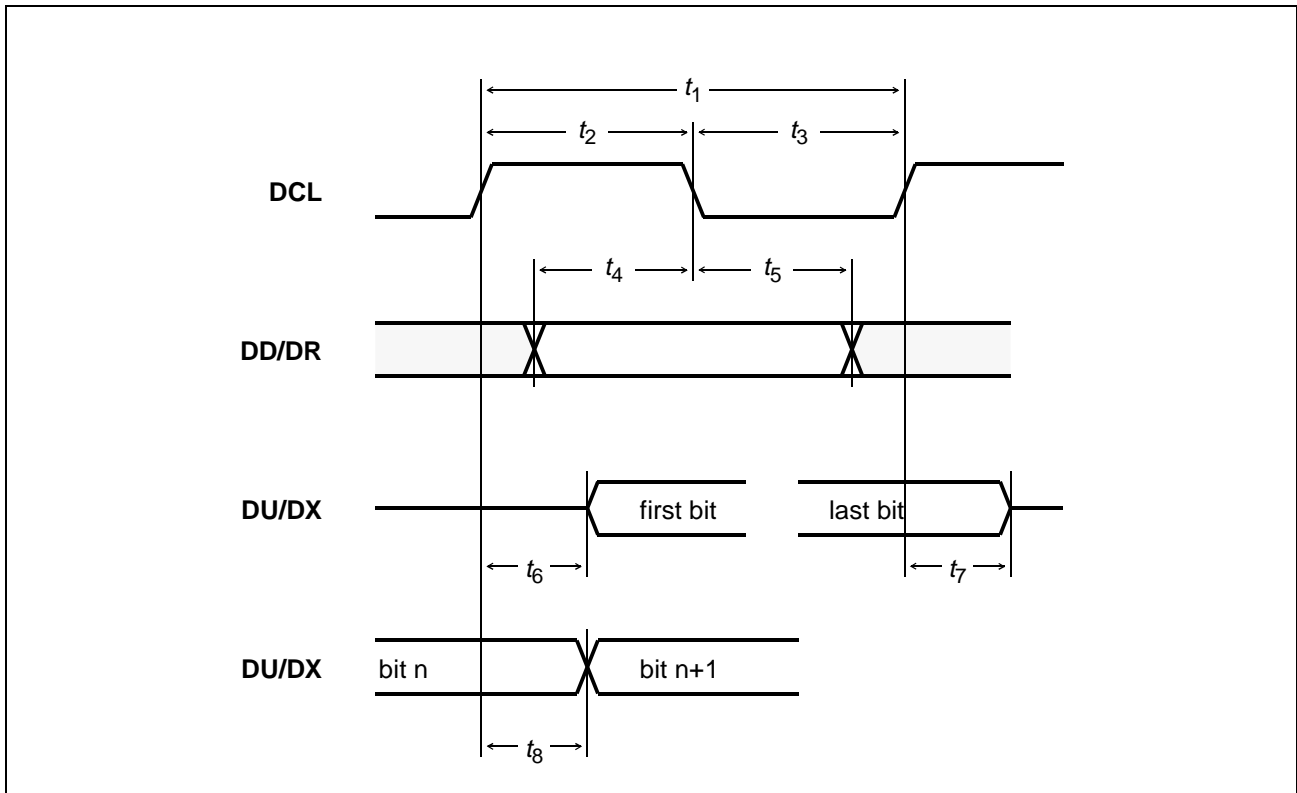

Figure 71 SSDI/IOM[®]-2 Interface - Bit Synchronization Timing

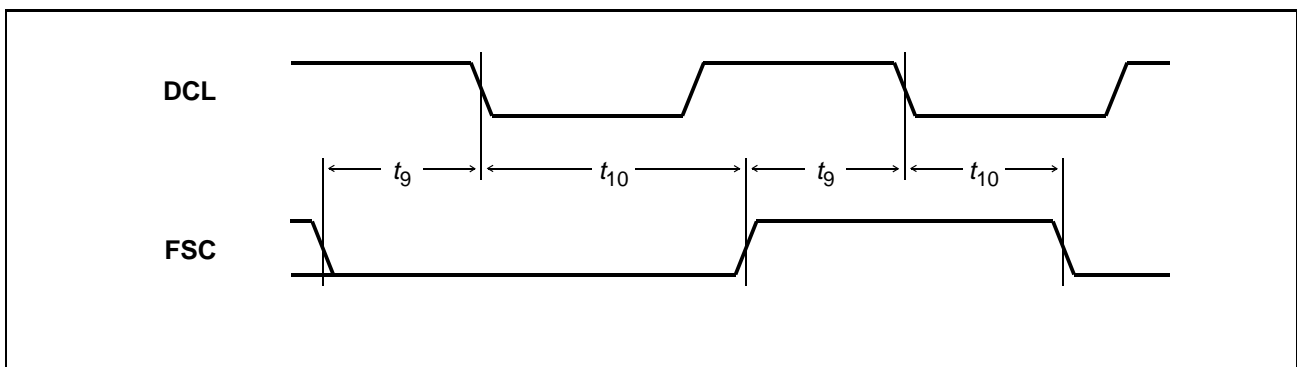

Figure 72 SSDI/IOM[®]-2 Interface - Frame Synchronization Timing

Parameter SSDI/IOM [®] -2 Interface	Symbol	Limit values		Unit
		Min	Max	
DCL period	t_1	90		ns
DCL high	t_2	35		ns
DCL low	t_3	35		ns
Input data setup	t_4	20		ns

Electrical Characteristics

Parameter SSDI/IOM [®] -2 Interface	Symbol	Limit values		Unit
		Min	Max	
Input data hold	t_5	20		ns
Output data from high impedance to active (FSC high or other than first timeslot)	t_6		30	ns
Output data from active to high impedance	t_7		30	ns
Output data delay from clock	t_8		30	ns
FSC setup	t_9	40		ns
FSC hold	t_{10}	40		ns
FSC jitter (deviation per frame)		-200	200	ns

Electrical Characteristics

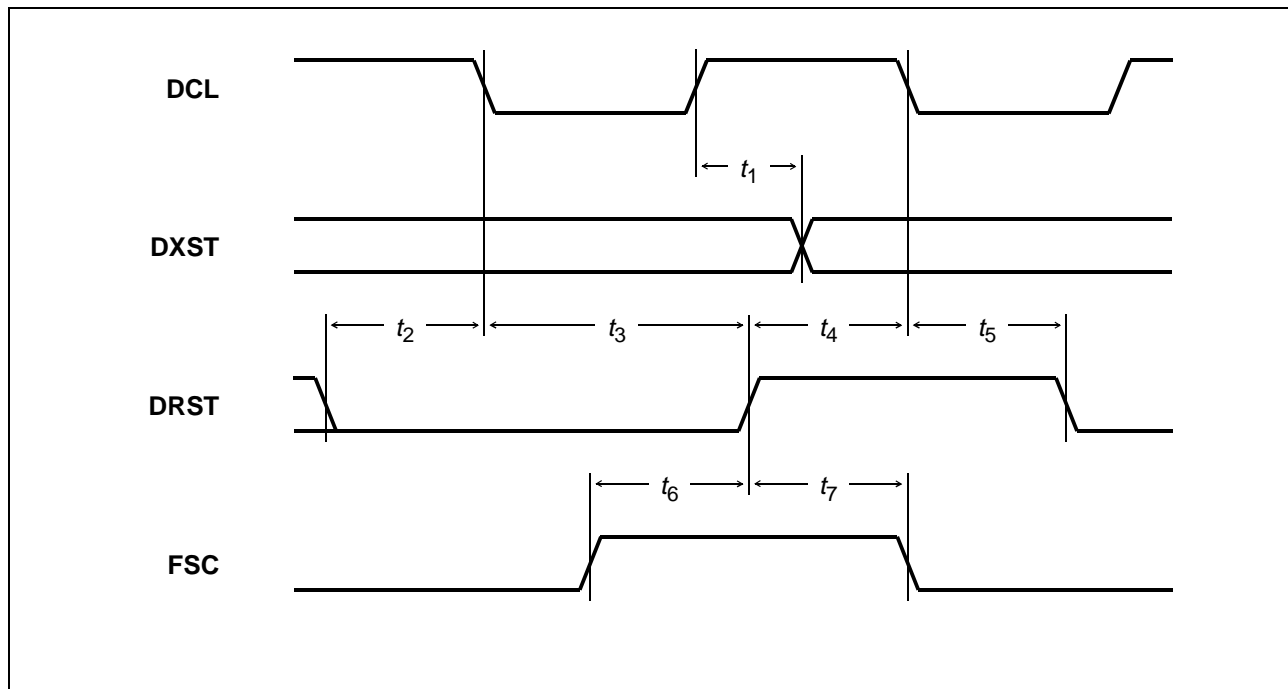

Figure 73 SSDI Interface - Strobe Timing

Parameter SSDI Interface	Symbol	Limit values		Unit
		Min	Max	
DXST delay	t_1		20	ns
DRST inactive setup	t_2	20		ns
DRST inactive hold	t_3	20		ns
DRST active setup	t_4	20		ns
DRST active hold	t_5	20		ns
FSC setup	t_6	8		DCL cycles
FSC hold	t_7	40		ns

Electrical Characteristics

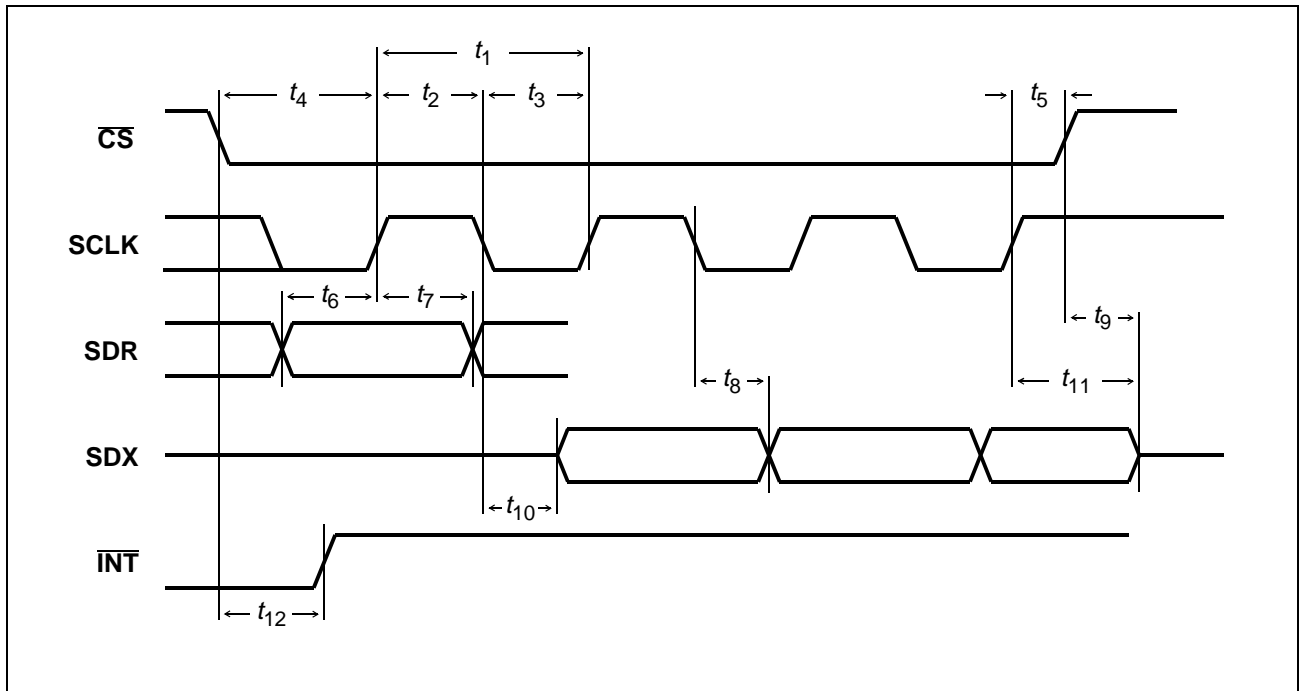

Figure 74 Serial Control Interface

Parameter SCI Interface	Symbol	Limit values		Unit
		Min	Max	
SCLK cycle time	t_1	500		ns
SCLK high time	t_2	100		ns
SCLK low time	t_3	100		ns
\overline{CS} setup time	t_4	40		ns
\overline{CS} hold time	t_5	10		ns
SDR setup time	t_6	40		ns
SDR hold time	t_7	40		ns
SDX data out delay	t_8		80	ns
\overline{CS} high to SDX tristate	t_9		40	ns
SCLK to SDX active	t_{10}		80	ns
SCLK to SDX tristate	t_{11}		40	ns
\overline{CS} to \overline{INT} delay	t_{12}		80	ns

Electrical Characteristics

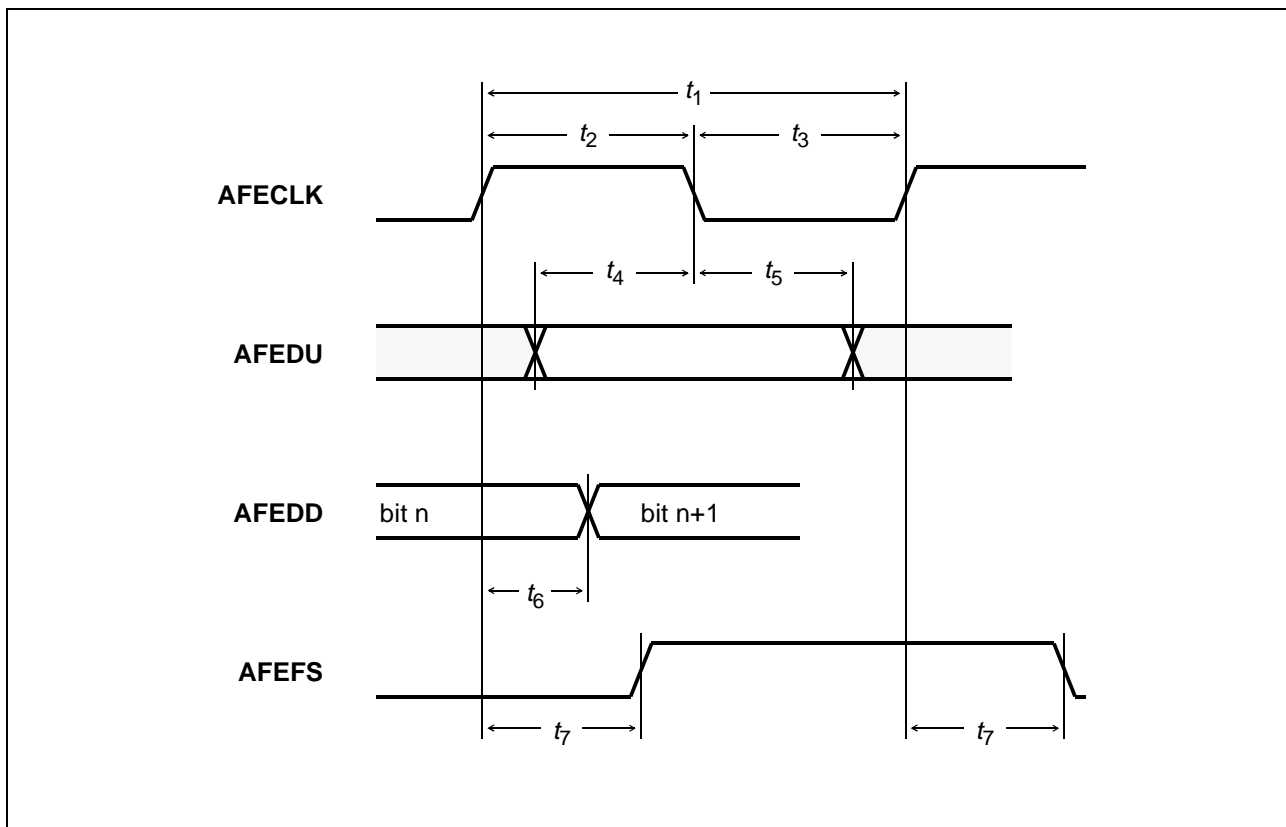

Figure 75 Analog Front End Interface

Parameter AFE Interface	Symbol	Limit values		Unit
		Min	Max	
AFECLK period	t_1	125	165	ns
AFECLK high	t_2	2		$1/f_{XTAL}$
AFECLK low	t_3	2		$1/f_{XTAL}$
AFEDU setup	t_4	20		ns
AFEDU hold	t_5	20		ns
AFEDD output delay	t_6		30	ns
AFEFS output delay	t_7		30	ns

Electrical Characteristics

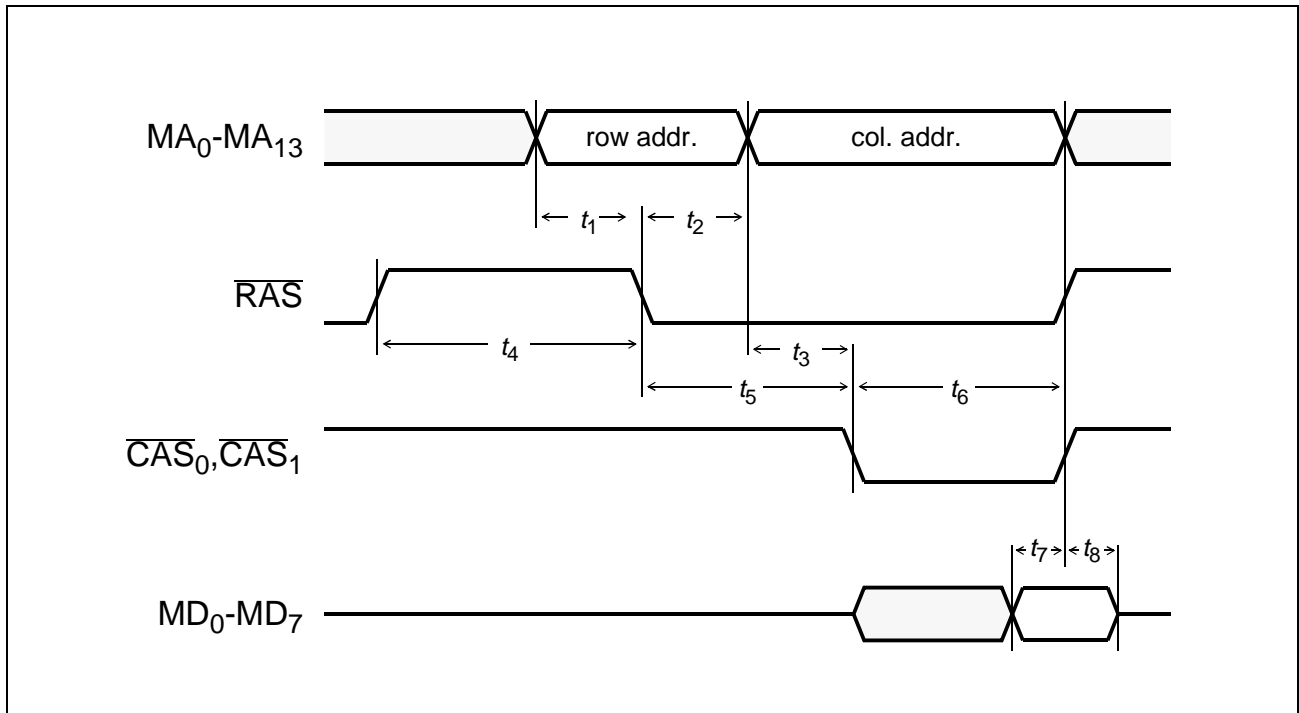

Figure 76 Memory Interface - DRAM Read Access

Parameter Memory Interface - DRAM Read Access	Symbol	Limit values		Unit
		Min	Max	
row address setup time	t_1	50		ns
row address hold time	t_2	50		ns
column address setup time	t_3	50		ns
$\overline{\text{RAS}}$ precharge time	t_4	110		ns
$\overline{\text{RAS}}$ to $\overline{\text{CAS}}$ delay	t_5	110	2000	ns
$\overline{\text{CAS}}$ pulse width	t_6	110	2000	ns
Data input setup time	t_7	40		ns
Data input hold time	t_8	0		ns

Electrical Characteristics

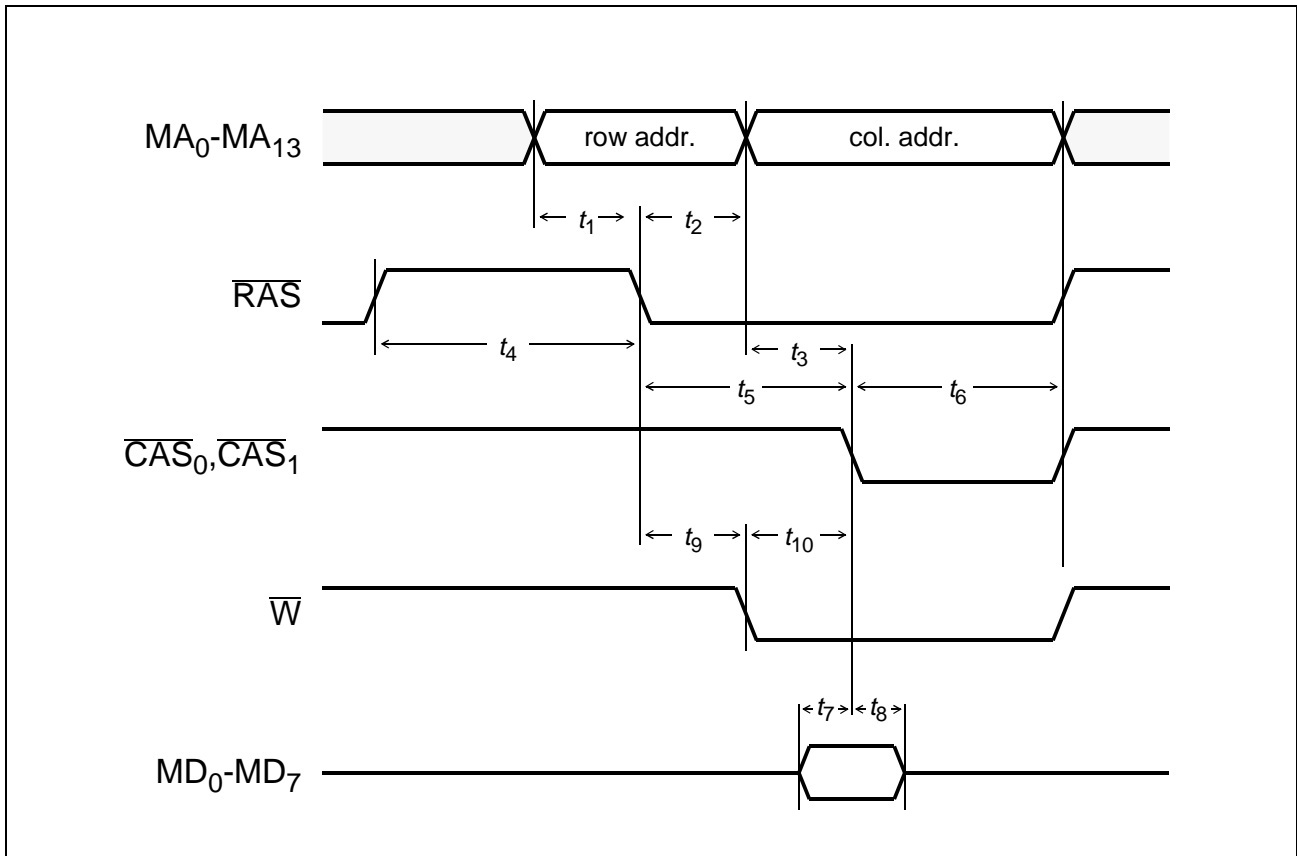

Figure 77 Memory Interface - DRAM Write Access

Parameter Memory Interface - DRAM Write Access	Symbol	Limit values		Unit
		Min	Max	
row address setup time	t_1	50		ns
row address hold time	t_2	50		ns
column address setup time	t_3	50		ns
RAS precharge time	t_4	110		ns
RAS to CAS delay	t_5	110	2000	ns
CAS pulse width	t_6	110	2000	ns
Data output setup time	t_7	100		ns
Data output hold time	t_8	50		ns
RAS to W delay	t_9	50		ns
W to CAS setup	t_{10}	50		ns

Electrical Characteristics

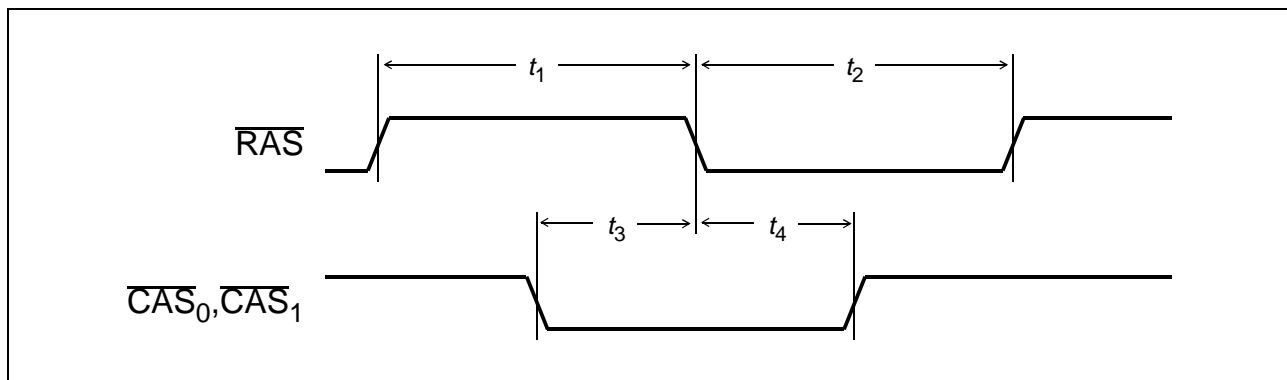

Figure 78 Memory Interface - DRAM Refresh Cycle

Parameter Memory Interface - DRAM Refresh Cycle	Symbol	Limit values		Unit
		Min	Max	
\overline{RAS} precharge time	t_1	100		ns
\overline{RAS} low time	t_2	200	5000	ns
\overline{CAS} setup	t_3	100		ns
\overline{CAS} hold	t_4	100		ns

Note: The frequency of the DRAM refresh cycle depends on the selected mode. In active mode or normal refresh mode (during power down) the minimal frequency is 64 kHz. In battery backup mode, the refresh frequency is 8 kHz.

Electrical Characteristics

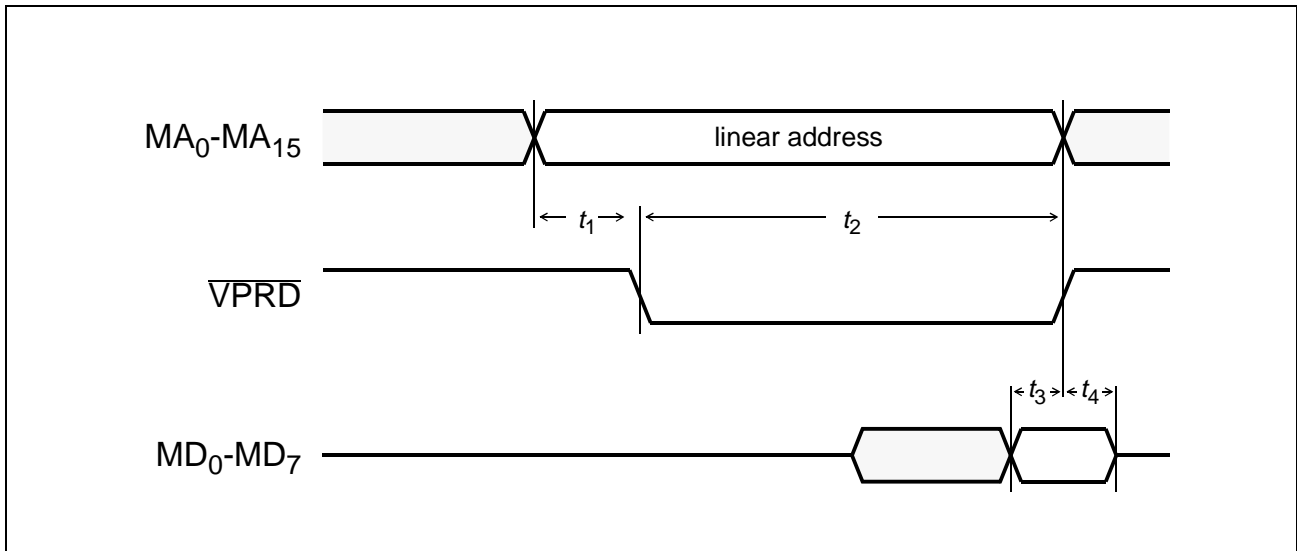

Figure 79 Memory Interface - EPROM Read

Parameter Memory Interface - EPROM Read	Symbol	Limit values		Unit
		Min	Max	
Address setup before \overline{VPRD}	t_1	110		ns
\overline{VPRD} low time	t_2	500		ns
Data setup time	t_3	40		ns
Data hold time	t_4	0		ns

Electrical Characteristics

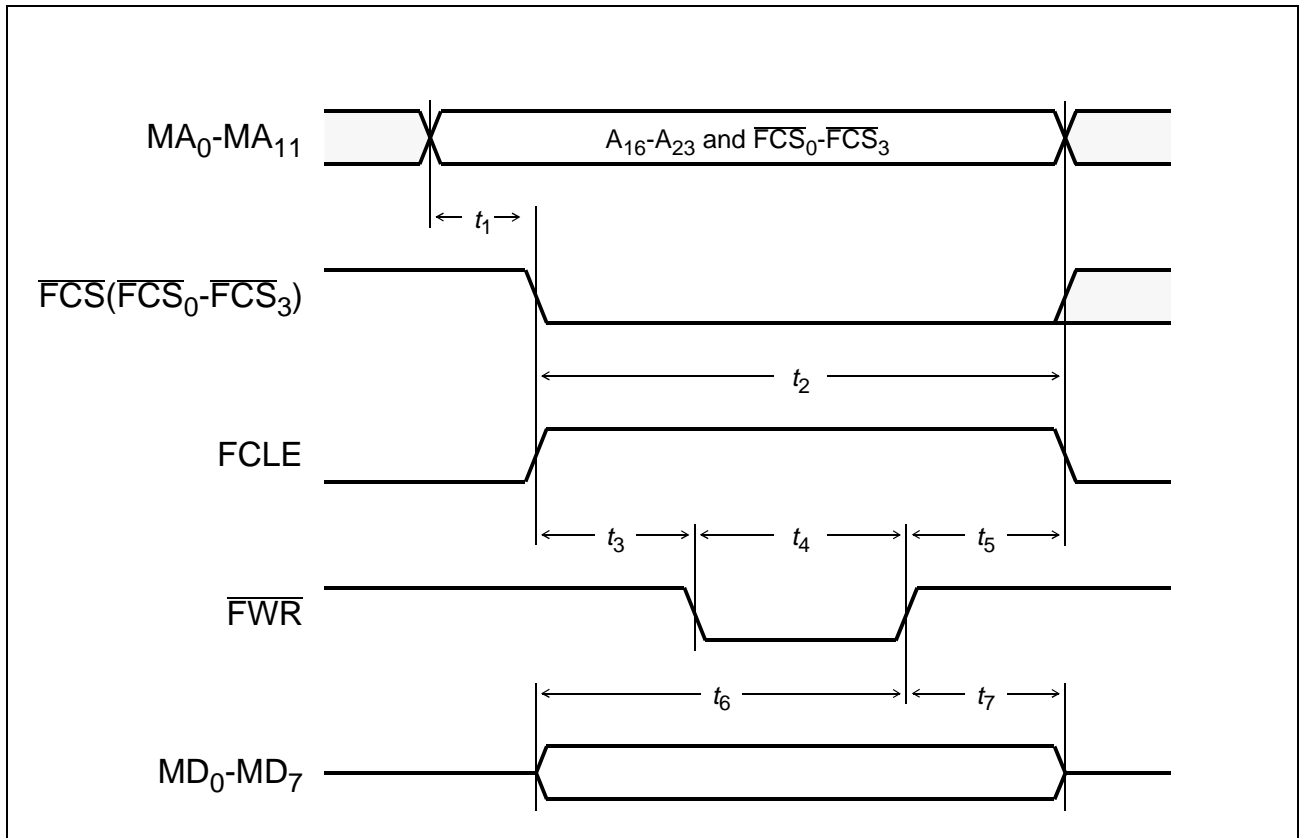

Figure 80 Memory Interface - Samsung Command Write

Parameter Memory Interface - Samsung Command Write	Symbol	Limit values		Unit
		Min	Max	
Address setup before FCS, FCLE	t ₁	100		ns
FCS low time, FCLE high time	t ₂	400		ns
FWR hold after FCLE rising	t ₃	100		ns
FWR low time	t ₄	200		ns
FWR setup before FCLE falling	t ₅	100		ns
Data setup time	t ₆	200		ns
Data hold time	t ₇	50		ns

Note: FCS stays low if other cycles follow for the same access.

Electrical Characteristics

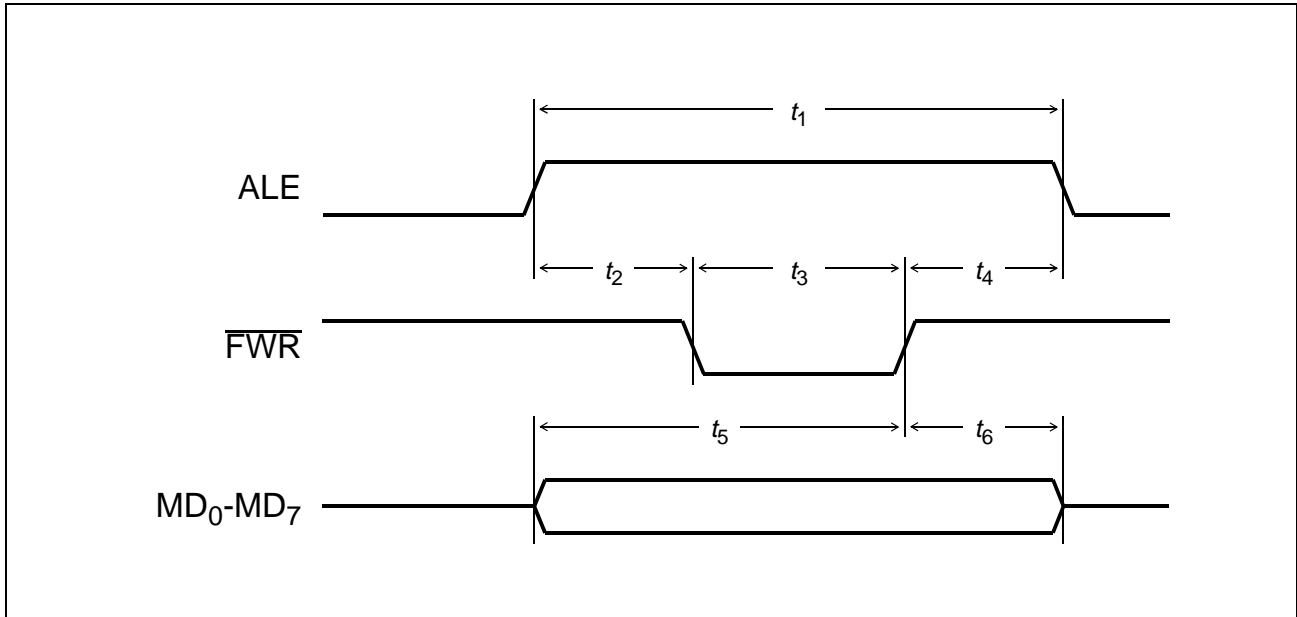

Figure 81 Memory Interface - Samsung Address Write

Parameter Memory Interface - Samsung Address Write	Symbol	Limit values		Unit
		Min	Max	
ALE high time	t_1	400		ns
FWR hold after ALE rising	t_2	100		ns
FWR low time	t_3	200		ns
FWR setup before ALE falling	t_4	100		ns
Data setup time	t_5	200		ns
Data hold time	t_6	50		ns

Electrical Characteristics

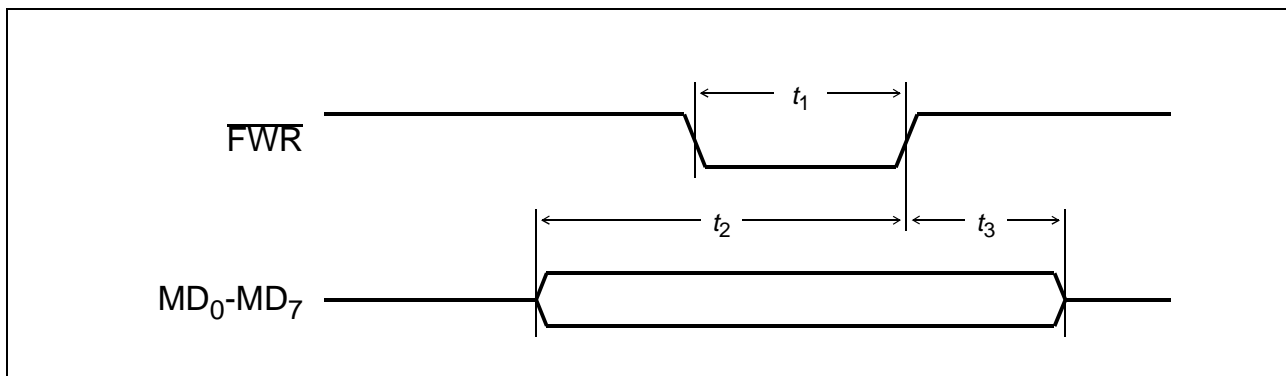

Figure 82 Memory Interface - Samsung Data Write

Parameter Memory Interface - Samsung Data Write	Symbol	Limit values		Unit
		Min	Max	
\overline{FWR} low time	t_1	200		ns
Data setup time	t_2	200		ns
Data hold time	t_3	50		ns

Electrical Characteristics

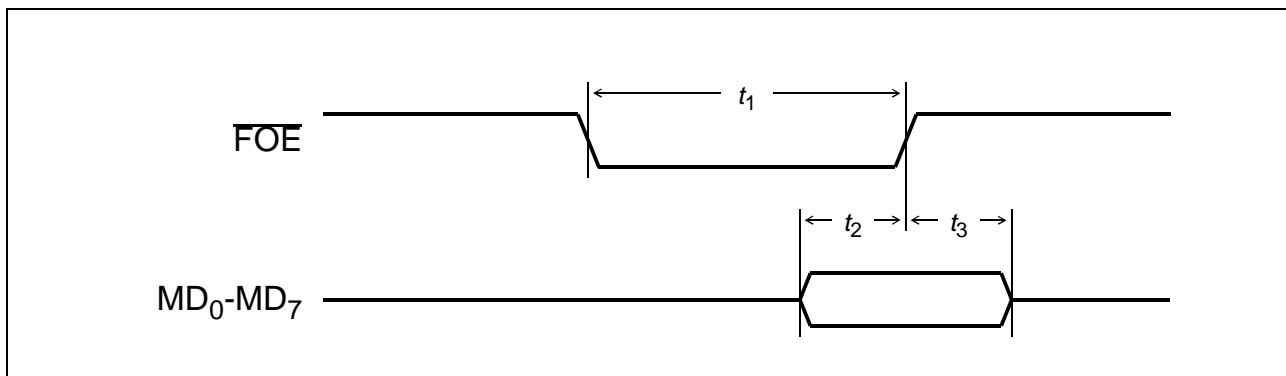

Figure 83 Memory Interface - Samsung Data Read

Parameter Memory Interface - Samsung Data Read	Symbol	Limit values		Unit
		Min	Max	
$\overline{\text{FOE}}$ low time	t_1	200		ns
Data setup time	t_2	40		ns
Data hold time	t_3	0		ns

Electrical Characteristics

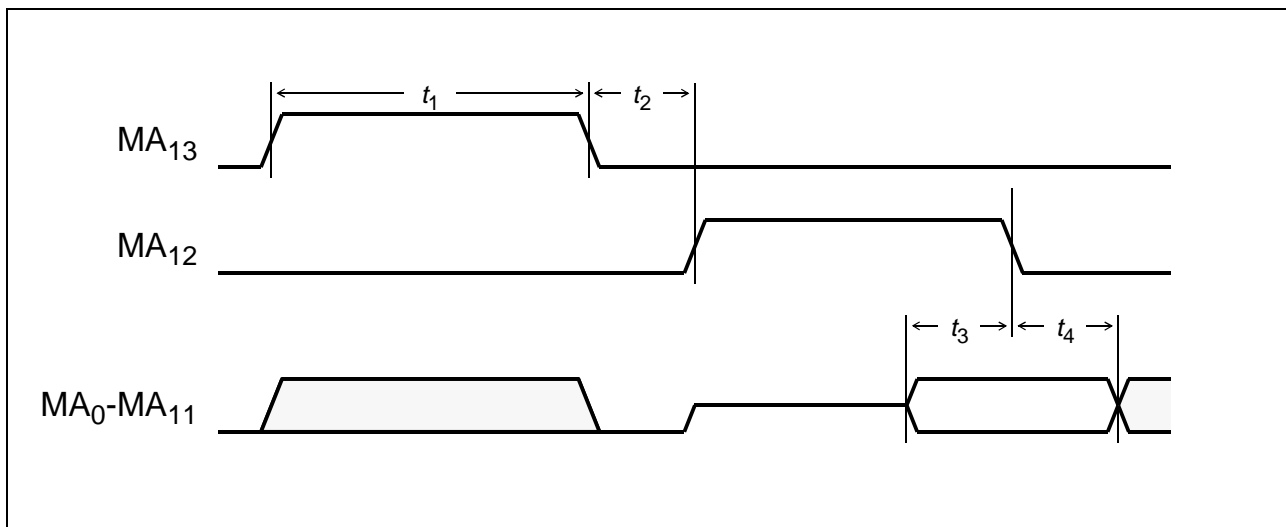

Figure 84 Auxiliary Parallel Port - Multiplex Mode

Parameter Auxiliary Port Interface - Multiplex Mode	Symbol	Limit values			Unit
		Min	Typ	Max	
Active time (MA ₀ -MA ₁₅)	t_1		2		ms
Gap time (MA ₀ -MA ₁₅)	t_2		125		μs
Data setup time	t_3	50			ns
Data hold time	t_4	0			ns

Electrical Characteristics

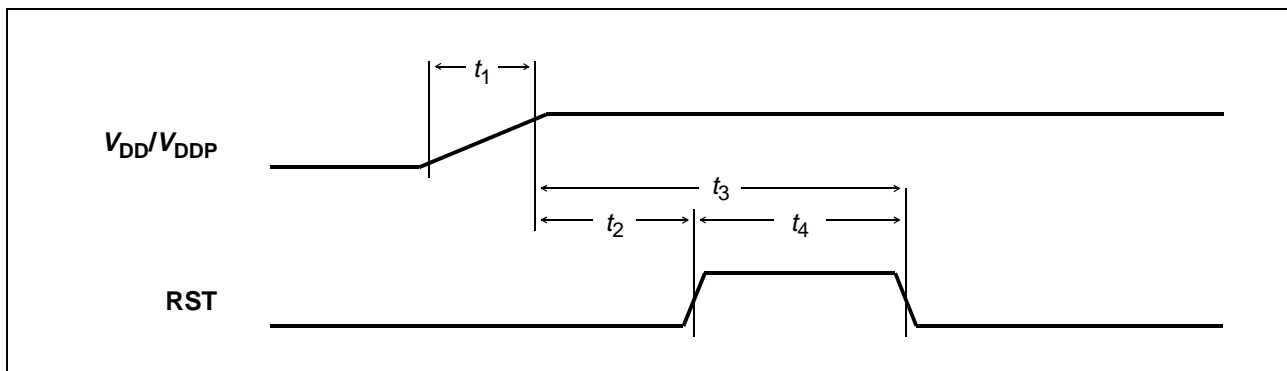
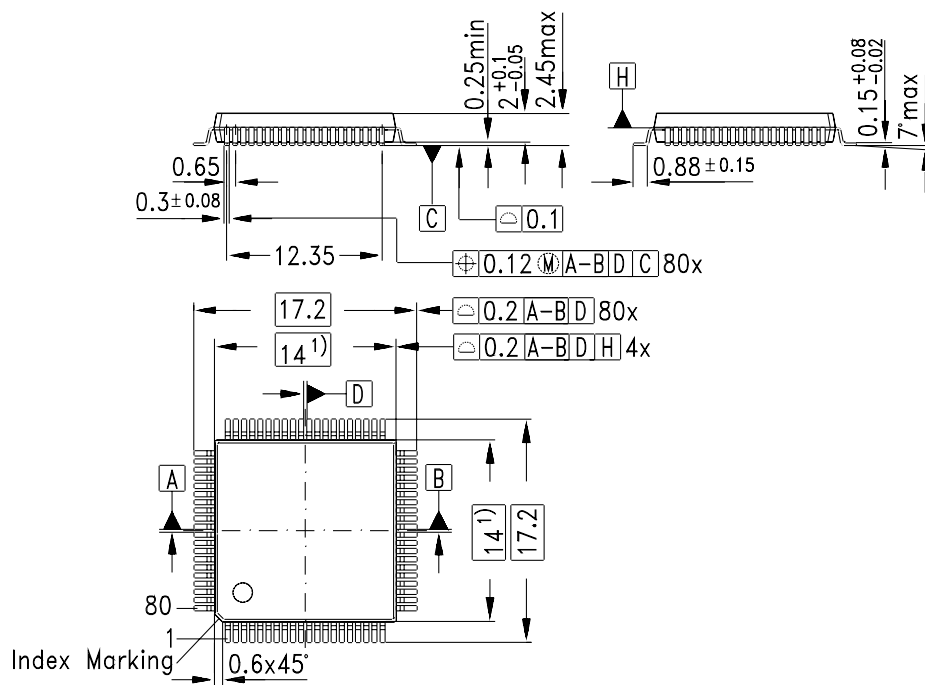

Figure 85 Reset Timing

Parameter Reset Timing	Symbol	Limit values		Unit
		Min	Max	
$V_{DD}/V_{DDP}/V_{DDA}$ rise time 5%-95%	t_1		20	ms
Supply voltages stable to RST high	t_2	0		ns
Supply voltages stable to RST low	t_3	0.1		ms
RST high time	t_4	1000		ns

5 Package Outlines

Plastic Package, P-MQFP-80 (SMD)
 (Plastic Metric Quad Flat Package)



1) Does not include plastic or metal protrusions of 0.25 max per side

Sorts of Packing

Package outlines for tubes, trays etc. are contained in our Data Book "Package Information".

SMD = Surface Mounted Device

Dimensions in mm

A

Abort

- Clearing Event 82, 119
- Functional Description 81
- Status Bit 109

Alert Tone Detector

- Electrical Characteristics 229
- Functional Description 46
- Registers 146–147
- Status Bit 110

Analog Front End Interface

- Electrical Characteristics 236
- Functional Description 55
- Registers 122–128
- Timing 92

ARAM

- see Memory Interface

Automatic Gain Control

- Functional Description 59
- Registers 169–175

Auxiliary Parallel Port

- Electrical Characteristics 245
- Mode Bits 112
- Multiplex Mode 107
- Registers 184–189
- Static Mode 107

C

Caller ID Decoder

- Electrical Characteristics 228
- Functional Description 49
- Registers 148–149
- Status Bits 109

CNG Detector

- Electrical Characteristics 229
- Functional Description 45
- Registers 142–145

- Status Bit 110

CPT Detector

- Electrical Characteristics 228
- Functional Description 47
- Registers 150–154
- Status Bit 110

D

Digital Interface

- Functional Description 56
- Mode Bits 112
- Registers 129–135

DRAM

- see Memory Interface

DTMF Detector

- Electrical Characteristics 228
- Functional Description 44
- Registers 159–161
- Status Bit 110

DTMF Generator

- Functional Description 51
- Registers 137–141

E

EPROM

- see Memory Interface

Equalizer

- Functional Description 61
- Registers 162–164

Execution Times

- File Commands 77

F

File

- Commands
 - Access File Descriptor 72
 - Compress 71
 - Create Next New 69
 - Delete 71

- Execution Times 77
- New File 69
- Open 69
- Read Binary Data 73
- Registers 176–180
- Restrictions 78
- Seek 70
- Status Bits 110
- Tailcut 71
- Write Binary Data 74
- Type
 - Audio 64
 - Binary 64
 - Phrase 65
- User Data Word 66
- Flash Memory
 - see Memory Interface
- G**
- Group Listening 38
- H**
- Hardware Configuration
 - Functional Description 82
 - Registers 111
- I**
- Interrupt
 - Functional Description 80
 - Pin Configuration 111
 - Register 121
- IOM®-2 Interface
 - Electrical Characteristics 232–233
 - Functional Description 86
 - see also: Digital Interface
- L**
- Line Echo Canceller
 - Functional Description 42
 - Registers 155–158
- Loudhearing 38
- M**
- Memory Interface
 - ARAM/DRAM
 - Connection Diagram 99
 - Electrical Characteristics 237–239
 - Refresh 101, 113
 - Timing 100
 - EPROM
 - Connection Diagram 102
 - Electrical Characteristics 240
 - Timing 102
 - Flash
 - Connection Diagram 103
 - Electrical Characteristics 241–244
 - In-Circuit Programming 98, 113
 - Multiple Devices 104
 - Timing 105
 - Register 120
 - Supported Devices 98
- Memory Management
 - Activation 68
 - Directories 63
 - ExecutionTimes 77
 - Files 64
 - Garbage Collection 72
 - Initialization 67
 - Memory Status 72
 - Overview 63
 - Status 65
- O**
- Oscillator
 - Electrical Characteristics 231
 - Mode Bits 112
- P**
- Power Down
 - Functional Description 79

- Status Bit 111
- R**
- Real Time Clock
 - Configuration Bits 111
 - Functional Description 79
 - Oscillator 231
 - Registers 182–183
- Recompression 71
- Reset
 - Electrical Characteristics 246
 - Functional Description 79
 - Register Values 115
- Restrictions
 - File Commands 78
 - Modules 83
- Revision
 - Functional Description 82
 - Register 119
- S**
- Serial Control Interface
 - Command Opcodes 97
 - Electrical Characteristics 235
 - Functional Description 94
- Signals
 - Encoding 117
 - Reference Table 117
- Speakerphone
 - Functional Description
 - Automatic Gain Control 38
 - Control 37
 - Echo Cancellation 28
 - Echo Suppression 30
 - Overview 27
 - Speech Comparator 35
 - Speech Detector 32
 - Registers 190–223
- Speech Coder
 - Functional Description 52
 - Registers 165–167
- Speech Decoder
 - Functional Description 54
 - Register 168
- SPS Outputs
 - Functional Description 38, 79
 - Register 181
- SSDI Interface
 - Electrical Characteristics 232–234
 - Functional Description 90
 - see also: Digital Interface
- Status Register
 - Definition 109
 - Update Timing 230
- U**
- Universal Attenuator
 - Functional Description 58
 - Register 136