

# 6.5mA, 220MHz, 1500V/ $\mu$ s Operational Amplifier with Programmable Current

January 2001

## FEATURES

- 220MHz Gain-Bandwidth Product
- 1500V/ $\mu$ s Slew Rate
- 7mA Maximum Supply Current
- Space Saving SOT-23 Packages
- Shutdown or Programmable Current Option
- 6nV/ $\sqrt{\text{Hz}}$  Input Noise Voltage
- 450MHz  $-3\text{dB}$  Bandwidth ( $A_V = 1$ )
- Unity-Gain Stable with  $C_{\text{LOAD}}$  Up to 100pF
- 1.5mV Maximum Input Offset Voltage
- 8 $\mu$ A Maximum Input Bias Current
- 800nA Maximum Input Offset Current
- 50mA Minimum Output Current,  $V_{\text{OUT}} = \pm 3\text{V}$
- $\pm 3.5\text{V}$  Minimum Input CMR,  $V_S = \pm 5\text{V}$
- Specified at  $\pm 5\text{V}$ , Single 5V Supplies
- Operating Temperature Range:  $-40^\circ\text{C}$  to  $85^\circ\text{C}$

## APPLICATIONS

- Wideband Amplifiers
- Buffers
- Active Filters
- Video and RF Amplification
- Communication Receivers
- Cable Drivers
- Data Acquisition Systems

## DESCRIPTION

The LT<sup>®</sup>1815 is a low power, high speed, very high slew rate operational amplifier with excellent DC performance. The LT1815 features higher bandwidth and slew rate, much lower input offset voltage and lower noise than devices with comparable supply current. A programmable current option (LT1815S6) allows power savings and flexibility by operating at reduced supply current and speed, as well as a complete shutdown reducing supply current to 150 $\mu$ A. The circuit topology is a voltage feedback amplifier with the slewing characteristics of a current feedback amplifier.

The output drives a 100 $\Omega$  load to  $\pm 3.8\text{V}$  with  $\pm 5\text{V}$  supplies. On a single 5V supply, the output swings from 1V to 4V with a 100 $\Omega$  load connected to 2.5V. The amplifier is stable with a 100pF capacitive load, which makes it useful in buffer and cable driver applications.

The LT1815 is manufactured on Linear Technology's advanced low voltage complementary bipolar process and is available in space saving 5-lead and 6-lead SOT23 packages, as well as in an SO-8.

 , LTC and LT are registered trademarks of Linear Technology Corporation.

## TYPICAL APPLICATION

Programmable Current Amplifier Switches  
from Low Power Mode to Full Speed Mode

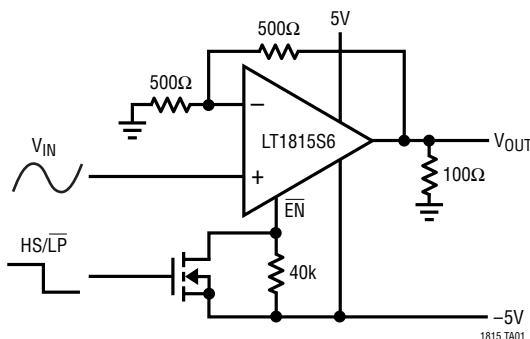

Distortion vs Frequency

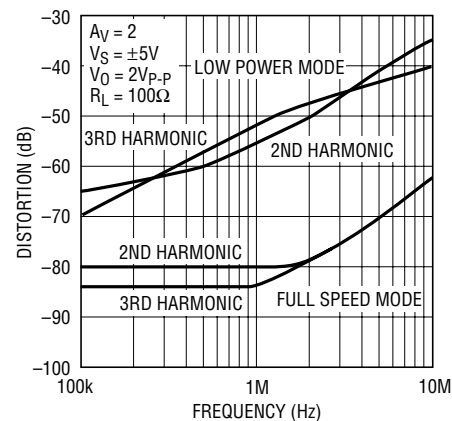

**ABSOLUTE MAXIMUM RATINGS** (Note 1)

Total Supply Voltage ( $V^+$ to $V^-$ ) .....	12.6V	Operating Temperature Range .....	-40°C to 85°C
Differential Input Voltage (Transient Only, Note 2) .....	$\pm 6V$	Specified Temperature Range (Note 8) ...	-40°C to 85°C
Input Voltage .....	$\pm V_S$	Maximum Junction Temperature .....	150°C
Output Short-Circuit Duration (Note 3) .....	Indefinite	Storage Temperature Range .....	-65°C to 150°C
		Lead Temperature (Soldering, 10 sec) .....	300°C

**PACKAGE/ORDER INFORMATION**

<p>S5 PACKAGE 5-LEAD PLASTIC SOT-23 <math>T_{JMAX} = 150^\circ\text{C}</math>, <math>\theta_{JA} = 250^\circ\text{C/W}</math> (NOTE 9)</p>		<p>S6 PACKAGE 6-LEAD PLASTIC SOT-23 <math>T_{JMAX} = 150^\circ\text{C}</math>, <math>\theta_{JA} = 230^\circ\text{C/W}</math> (NOTE 9)</p>		<p>S8 PACKAGE 8-LEAD PLASTIC SO <math>T_{JMAX} = 150^\circ\text{C}</math>, <math>\theta_{JA} = 150^\circ\text{C/W}</math> (NOTE 9)</p>	
ORDER PART NUMBER	S5 PART MARKING	ORDER PART NUMBER	S6 PART MARKING	ORDER PART NUMBER	S8 PART MARKING
LT1815CS5 LT1815IS5	LTUP LTVC	LT1815CS6 LT1815IS6	LTUL LTVD	LT1815CS8 LT1815IS8	1815 1815I

Consult factory for parts specified with wider operating temperature ranges.

**ELECTRICAL CHARACTERISTICS** The ● denotes the specifications which apply over the full operating temperature range, otherwise specifications are at  $T_A = 25^\circ\text{C}$ . (Note 8)  $V_S = \pm 5V$ ,  $V_{CM} = 0V$  unless otherwise noted. For 6-lead SOT-23 version, Pin 5 must be pulled down to  $V^-$  through  $75\Omega$  or less, unless otherwise noted.

SYMBOL	PARAMETER	CONDITIONS	MIN	TYP	MAX	UNITS
$V_{OS}$	Input Offset Voltage	(Note 4)		0.2	1.5	mV
		$T_A = 0^\circ\text{C}$ to $70^\circ\text{C}$ (Note 4)	●		2.0	mV
		$T_A = -40^\circ\text{C}$ to $85^\circ\text{C}$ (Note 4)	●		3.0	mV
$V_{OS}$	Input Offset Voltage (Low Power Mode)	6-Lead SOT-23, $40k\Omega$ Between $\overline{EN}$ and $V^-$		1	7	mV
		$T_A = 0^\circ\text{C}$ to $70^\circ\text{C}$	●		9	mV
		$T_A = -40^\circ\text{C}$ to $85^\circ\text{C}$	●		10	mV
$\frac{\Delta V_{OS}}{\Delta T}$	Input Offset Voltage Drift	$T_A = 0^\circ\text{C}$ to $70^\circ\text{C}$ (Note 7)	●	10	15	$\mu\text{V}/^\circ\text{C}$
		$T_A = -40^\circ\text{C}$ to $85^\circ\text{C}$ (Note 7)	●	10	30	$\mu\text{V}/^\circ\text{C}$
$I_{OS}$	Input Offset Current	$T_A = 0^\circ\text{C}$ to $70^\circ\text{C}$	●	60	800	nA
		$T_A = -40^\circ\text{C}$ to $85^\circ\text{C}$	●		1000	nA
			●		1200	nA
$I_B$	Input Bias Current	$T_A = 0^\circ\text{C}$ to $70^\circ\text{C}$	●	-2.0	$\pm 8$	$\mu\text{A}$
		$T_A = -40^\circ\text{C}$ to $85^\circ\text{C}$	●		$\pm 10$	$\mu\text{A}$
			●		$\pm 12$	$\mu\text{A}$

**ELECTRICAL CHARACTERISTICS** The ● denotes the specifications which apply over the full operating temperature range, otherwise specifications are at  $T_A = 25^\circ\text{C}$ . (Note 8)  $V_S = \pm 5\text{V}$ ,  $V_{CM} = 0\text{V}$  unless otherwise noted. For 6-lead SOT-23 version, Pin 5 must be pulled down to  $V^-$  through  $75\Omega$  or less, unless otherwise noted.

SYMBOL	PARAMETER	CONDITIONS	MIN	TYP	MAX	UNITS
$e_n$	Input Noise Voltage Density	$f = 10\text{kHz}$		6		$\text{nV}/\sqrt{\text{Hz}}$
$i_n$	Input Noise Current Density	$f = 10\text{kHz}$		1.3		$\text{pA}/\sqrt{\text{Hz}}$
$R_{IN}$	Input Resistance	$V_{CM} = \pm 3.5\text{V}$ Differential	1.5	5 750		$\text{M}\Omega$ $\text{k}\Omega$
$C_{IN}$	Input Capacitance			2		$\text{pF}$
$V_{CM}$	Input Voltage Range	Guaranteed by CMRR $T_A = -40^\circ\text{C}$ to $85^\circ\text{C}$	● $\pm 3.5$ ● $\pm 3.5$	$\pm 4.2$		V V
CMRR	Common Mode Rejection Ratio	$V_{CM} = \pm 3.5\text{V}$ $T_A = 0^\circ\text{C}$ to $70^\circ\text{C}$ $T_A = -40^\circ\text{C}$ to $85^\circ\text{C}$	● 75 ● 73 ● 72	85		$\text{dB}$ $\text{dB}$ $\text{dB}$
	Minimum Supply Voltage	Guaranteed by PSRR $T_A = -40^\circ\text{C}$ to $85^\circ\text{C}$	●	$\pm 1.25$	$\pm 2$ $\pm 2$	V V
PSRR	Power Supply Rejection Ratio	$V_S = \pm 2\text{V}$ to $\pm 5.5\text{V}$ $T_A = 0^\circ\text{C}$ to $70^\circ\text{C}$ $T_A = -40^\circ\text{C}$ to $85^\circ\text{C}$	● 78 ● 76 ● 75	97		$\text{dB}$ $\text{dB}$ $\text{dB}$
$A_{VOL}$	Large-Signal Voltage Gain	$V_{OUT} = \pm 3\text{V}$ , $R_L = 500\Omega$ $T_A = 0^\circ\text{C}$ to $70^\circ\text{C}$ $T_A = -40^\circ\text{C}$ to $85^\circ\text{C}$	● 1.5 ● 1.0 ● 0.8	3		$\text{V}/\text{mV}$ $\text{V}/\text{mV}$ $\text{V}/\text{mV}$
		$V_{OUT} = \pm 3\text{V}$ , $R_L = 100\Omega$ $T_A = 0^\circ\text{C}$ to $70^\circ\text{C}$ $T_A = -40^\circ\text{C}$ to $85^\circ\text{C}$	● 0.7 ● 0.5 ● 0.4	1.5		$\text{V}/\text{mV}$ $\text{V}/\text{mV}$ $\text{V}/\text{mV}$
$V_{OUT}$	Maximum Output Swing	$R_L = 500\Omega$ , 30mV Overdrive $T_A = 0^\circ\text{C}$ to $70^\circ\text{C}$ $T_A = -40^\circ\text{C}$ to $85^\circ\text{C}$	● $\pm 3.8$ ● $\pm 3.7$ ● $\pm 3.6$	$\pm 4.1$		V V V
		$R_L = 100\Omega$ , 30mV Overdrive $T_A = 0^\circ\text{C}$ to $70^\circ\text{C}$ $T_A = -40^\circ\text{C}$ to $85^\circ\text{C}$	● $\pm 3.05$ ● $\pm 3.25$ ● $\pm 3.15$	$\pm 3.8$		V V V
$I_{OUT}$	Maximum Output Current	$V_{OUT} = \pm 3\text{V}$ , 30mV Overdrive $T_A = 0^\circ\text{C}$ to $70^\circ\text{C}$ $T_A = -40^\circ\text{C}$ to $85^\circ\text{C}$	● $\pm 50$ ● $\pm 45$ ● $\pm 40$	$\pm 75$		$\text{mA}$ $\text{mA}$ $\text{mA}$
	Maximum Output Current (Low Power Mode)	6-Lead SOT-23; $40\text{k}\Omega$ Between $\overline{\text{EN}}$ and $V^-$ ; $V_{OUT} = \pm 3\text{V}$ , 30mV Overdrive $T_A = 0^\circ\text{C}$ to $70^\circ\text{C}$ $T_A = -40^\circ\text{C}$ to $85^\circ\text{C}$	● $\pm 50$ ● $\pm 40$ ● $\pm 30$	$\pm 75$		$\text{mA}$ $\text{mA}$ $\text{mA}$
$I_{SC}$	Output Short-Circuit Current	$V_{OUT} = 0\text{V}$ , 1V Overdrive (Note 3) $T_A = 0^\circ\text{C}$ to $70^\circ\text{C}$ $T_A = -40^\circ\text{C}$ to $85^\circ\text{C}$	● $\pm 100$ ● $\pm 90$ ● $\pm 70$	$\pm 160$		$\text{mA}$ $\text{mA}$ $\text{mA}$
SR	Slew Rate	$A_V = -1$ (Note 5) $T_A = 0^\circ\text{C}$ to $70^\circ\text{C}$ $T_A = -40^\circ\text{C}$ to $85^\circ\text{C}$	● 900 ● 750 ● 600	1500		$\text{V}/\mu\text{s}$ $\text{V}/\mu\text{s}$ $\text{V}/\mu\text{s}$
FPBW	Full-Power Bandwidth	$6V_{P-P}$ (Note 6), $V_S = \pm 5\text{V}$		80		$\text{MHz}$
GBW	Gain-Bandwidth Product	$f = 200\text{kHz}$ , $R_L = 500\Omega$ $T_A = 0^\circ\text{C}$ to $70^\circ\text{C}$ $T_A = -40^\circ\text{C}$ to $85^\circ\text{C}$	● 150 ● 140 ● 130	220		$\text{MHz}$ $\text{MHz}$ $\text{MHz}$
	Gain-Bandwidth Product (Low Power Mode)	6-Lead SOT-23; $40\text{k}\Omega$ Between $\overline{\text{EN}}$ and $V^-$ ; $f = 200\text{kHz}$ , $R_L = 500\Omega$ $T_A = 0^\circ\text{C}$ to $70^\circ\text{C}$ $T_A = -40^\circ\text{C}$ to $85^\circ\text{C}$	● 40 ● 35 ● 30	60		$\text{MHz}$ $\text{MHz}$ $\text{MHz}$

**ELECTRICAL CHARACTERISTICS** The ● denotes the specifications which apply over the full operating temperature range, otherwise specifications are at  $T_A = 25^\circ\text{C}$ . (Note 8)  $V_S = \pm 5\text{V}$ ,  $V_{CM} = 0\text{V}$  unless otherwise noted. For 6-lead SOT-23 version, Pin 5 must be pulled down to  $V^-$  through  $75\Omega$  or less, unless otherwise noted.

SYMBOL	PARAMETER	CONDITIONS	MIN	TYP	MAX	UNITS
-3dB BW	-3dB Bandwidth	$A_V = 1, R_L = 500\Omega$		450		MHz
$t_r, t_f$	Rise Time, Fall Time	$A_V = 1, 10\% \text{ to } 90\%, 0.1\text{V}, R_L = 100\Omega$		1.0		ns
$t_{PD}$	Propagation Delay	$A_V = 1, 50\% \text{ to } 50\%, 0.1\text{V}, R_L = 100\Omega$		1.4		ns
OS	Overshoot	$A_V = 1, 0.1\text{V}; R_L = 100\Omega$		25		%
$t_S$	Settling Time	$A_V = -1, 0.1\%, 5\text{V}$		15		ns
THD	Total Harmonic Distortion	$A_V = 2, f = 5\text{MHz}, V_{OUT} = 2V_{P-P}, R_L = 500\Omega$		-70		dB
dG	Differential Gain	$A_V = 2, V_{OUT} = 2V_{P-P}, R_L = 150\Omega$		0.08		%
dP	Differential Phase	$A_V = 2, V_{OUT} = 2V_{P-P}, R_L = 150\Omega$		0.04		Deg
$R_{OUT}$	Output Resistance	$A_V = -1, f = 1\text{MHz}$		0.20		$\Omega$
$I_S$	Supply Current	$T_A = 0^\circ\text{C to } 70^\circ\text{C}$	●	6.5	7	mA
		$T_A = -40^\circ\text{C to } 85^\circ\text{C}$	●		9	mA
	Supply Current (Low Power Mode)	6-Lead SOT-23, $40k\Omega$ Between $\overline{EN}$ and $V^-$ $T_A = 0^\circ\text{C to } 70^\circ\text{C}$ $T_A = -40^\circ\text{C to } 85^\circ\text{C}$	●	1.2	1.5	mA
Supply Current (Shutdown Mode)	6-Lead SOT-23, $\overline{EN} = V^- + 2\text{V}$ $T_A = 0^\circ\text{C to } 70^\circ\text{C}$ $T_A = -40^\circ\text{C to } 85^\circ\text{C}$	●		1.8	2.0	mA
		●	150	200	$\mu\text{A}$	
$I_{\overline{EN}}$	$\overline{EN}$ Pin Current	$T_A = 0^\circ\text{C to } 70^\circ\text{C}$	●	-150	-100	$\mu\text{A}$
		$T_A = -40^\circ\text{C to } 85^\circ\text{C}$	●	-175		$\mu\text{A}$
	$\overline{EN}$ Pin Current (Shutdown Mode)	6-Lead SOT-23, $\overline{EN} = V^- + 2\text{V}$ $T_A = 0^\circ\text{C to } 70^\circ\text{C}$ $T_A = -40^\circ\text{C to } 85^\circ\text{C}$	●	-1.0	0	1.0
●		●	-1.5	1.5	$\mu\text{A}$	
●		●	-2.0	2.0	$\mu\text{A}$	

The ● denotes the specifications which apply over the full operating temperature range, otherwise specifications are at  $T_A = 25^\circ\text{C}$ . (Note 8)  $V_S = 5\text{V}, 0\text{V}; V_{CM} = 2.5\text{V}, R_L$  to  $2.5\text{V}$ , unless otherwise noted. For 6-lead SOT-23 version, Pin 5 must be pulled down to  $V^-$  through  $75\Omega$  or less, unless otherwise noted.

SYMBOL	PARAMETER	CONDITIONS	MIN	TYP	MAX	UNITS
$V_{OS}$	Input Offset Voltage	(Note 4)		0.4	2.0	mV
		$T_A = 0^\circ\text{C to } 70^\circ\text{C}$ (Note 4)	●		2.5	mV
		$T_A = -40^\circ\text{C to } 85^\circ\text{C}$ (Note 4)	●		3.5	mV
Input Offset Voltage (Low Power Mode)	6-Lead SOT-23, $40k\Omega$ Between $\overline{EN}$ and $V^-$ $T_A = 0^\circ\text{C to } 70^\circ\text{C}$ $T_A = -40^\circ\text{C to } 85^\circ\text{C}$	●		1	7	mV
		●			9	mV
		●			10	mV
$\frac{\Delta V_{OS}}{\Delta T}$	Input Offset Voltage Drift	$T_A = 0^\circ\text{C to } 70^\circ\text{C}$ (Note 7)	●	10	15	$\mu\text{V}/^\circ\text{C}$
		$T_A = -40^\circ\text{C to } 85^\circ\text{C}$ (Note 7)	●	10	30	$\mu\text{V}/^\circ\text{C}$
$I_{OS}$	Input Offset Current	$T_A = 0^\circ\text{C to } 70^\circ\text{C}$	●	60	800	nA
		$T_A = -40^\circ\text{C to } 85^\circ\text{C}$	●		1000	nA
			●		1200	nA
$I_B$	Input Bias Current	$T_A = 0^\circ\text{C to } 70^\circ\text{C}$	●	-2.4	$\pm 8$	$\mu\text{A}$
		$T_A = -40^\circ\text{C to } 85^\circ\text{C}$	●		$\pm 10$	$\mu\text{A}$
			●		$\pm 12$	$\mu\text{A}$
$e_n$	Input Noise Voltage Density	$f = 10\text{kHz}$		6		$\text{nV}/\sqrt{\text{Hz}}$
$i_n$	Input Noise Current Density	$f = 10\text{kHz}$		1.3		$\text{pA}/\sqrt{\text{Hz}}$

**ELECTRICAL CHARACTERISTICS** The ● denotes the specifications which apply over the full operating temperature range, otherwise specifications are at  $T_A = 25^\circ\text{C}$ . (Note 8)  $V_S = 5\text{V}$ ,  $0\text{V}$ ;  $V_{CM} = 2.5\text{V}$ ,  $R_L$  to  $2.5\text{V}$ , unless otherwise noted. For 6-lead SOT-23 version, Pin 5 must be pulled down to  $V^-$  through  $75\Omega$  or less, unless otherwise noted.

SYMBOL	PARAMETER	CONDITIONS	MIN	TYP	MAX	UNITS
$R_{IN}$	Input Resistance	$V_{CM} = 1.5\text{V to } 3.5\text{V}$ Differential	1.5	5		$M\Omega$
				750		$k\Omega$
$C_{IN}$	Input Capacitance			2		$\mu\text{F}$
$V_{CM}$	Input Voltage Range (High)	Guaranteed by CMRR $T_A = -40^\circ\text{C to } 85^\circ\text{C}$	● 3.5	4.2		V
	Input Voltage Range (Low)	Guaranteed by CMRR $T_A = -40^\circ\text{C to } 85^\circ\text{C}$	●	0.8	1.5	V
CMRR	Common Mode Rejection Ratio	$V_{CM} = 1.5\text{V to } 3.5\text{V}$ $T_A = 0^\circ\text{C to } 70^\circ\text{C}$ $T_A = -40^\circ\text{C to } 85^\circ\text{C}$	● 73	82		$\text{dB}$
			● 71			$\text{dB}$
			● 70			$\text{dB}$
	Minimum Supply Voltage	Guaranteed by PSRR $T_A = -40^\circ\text{C to } 85^\circ\text{C}$	●	$\pm 1.25$	$\pm 2$	V
					$\pm 2$	V
$A_{VOL}$	Large-Signal Voltage Gain	$V_{OUT} = 1.5\text{V to } 3.5\text{V}$ , $R_L = 500\Omega$ $T_A = 0^\circ\text{C to } 70^\circ\text{C}$ $T_A = -40^\circ\text{C to } 85^\circ\text{C}$	● 1.0	2		$\text{V/mV}$
			● 0.7			$\text{V/mV}$
		● 0.6			$\text{V/mV}$	
		$V_{OUT} = 1.5\text{V to } 3.5\text{V}$ , $R_L = 100\Omega$ $T_A = 0^\circ\text{C to } 70^\circ\text{C}$ $T_A = -40^\circ\text{C to } 85^\circ\text{C}$	● 0.7	1.5		$\text{V/mV}$
● 0.5				$\text{V/mV}$		
$V_{OUT}$	Maximum Output Swing (High)	$R_L = 500\Omega$ , 30mV Overdrive $T_A = 0^\circ\text{C to } 70^\circ\text{C}$ $T_A = -40^\circ\text{C to } 85^\circ\text{C}$	● 3.9	4.2		V
			● 3.8			V
			● 3.7			V
	Maximum Output Swing (Low)	$R_L = 100\Omega$ , 30mV Overdrive $T_A = 0^\circ\text{C to } 70^\circ\text{C}$ $T_A = -40^\circ\text{C to } 85^\circ\text{C}$	● 3.7	4		V
			● 3.6			V
			● 3.5			V
Maximum Output Swing (Low)	$R_L = 500\Omega$ , 30mV Overdrive $T_A = 0^\circ\text{C to } 70^\circ\text{C}$ $T_A = -40^\circ\text{C to } 85^\circ\text{C}$	●	0.8	1.1	V	
		●		1.2	V	
		●		1.3	V	
$I_{OUT}$	Maximum Output Current	$V_{OUT} = 1.5\text{V or } 3.5\text{V}$ , 30mV Overdrive $T_A = 0^\circ\text{C to } 70^\circ\text{C}$ $T_A = -40^\circ\text{C to } 85^\circ\text{C}$	● $\pm 30$	$\pm 50$		$\text{mA}$
			● $\pm 25$			$\text{mA}$
			● $\pm 20$			$\text{mA}$
$I_{OUT}$	Maximum Output Current (Low Power Mode)	6-Lead SOT-23; $40k\Omega$ Between $\overline{EN}$ and $V^-$ ; $V_{OUT} = 1.5\text{V or } 3.5\text{V}$ , 30mV Overdrive $T_A = 0^\circ\text{C to } 70^\circ\text{C}$ $T_A = -40^\circ\text{C to } 85^\circ\text{C}$	● $\pm 30$	$\pm 50$		$\text{mA}$
			● $\pm 25$			$\text{mA}$
			● $\pm 20$			$\text{mA}$
$I_{SC}$	Output Short-Circuit Current	$V_{OUT} = 2.5\text{V}$ , 1V Overdrive (Note 3) $T_A = 0^\circ\text{C to } 70^\circ\text{C}$ $T_A = -40^\circ\text{C to } 85^\circ\text{C}$	● $\pm 80$	$\pm 140$		$\text{mA}$
			● $\pm 70$			$\text{mA}$
			● $\pm 50$			$\text{mA}$
SR	Slew Rate	$A_V = -1$ (Note 5) $T_A = 0^\circ\text{C to } 70^\circ\text{C}$ $T_A = -40^\circ\text{C to } 85^\circ\text{C}$	● 450	750		$\text{V}/\mu\text{s}$
			● 375			$\text{V}/\mu\text{s}$
			● 300			$\text{V}/\mu\text{s}$

**ELECTRICAL CHARACTERISTICS** The ● denotes the specifications which apply over the full operating temperature range, otherwise specifications are at  $T_A = 25^\circ\text{C}$ . (Note 8)  $V_S = 5\text{V}$ ,  $0\text{V}$ ;  $V_{\text{CM}} = 2.5\text{V}$ ,  $R_L$  to  $2.5\text{V}$ , unless otherwise noted. For 6-lead SOT-23 version, Pin 5 must be pulled down to  $V^-$  through  $75\Omega$  or less, unless otherwise noted.

SYMBOL	PARAMETER	CONDITIONS	MIN	TYP	MAX	UNITS
FPBW	Full-Power Bandwidth	$2V_{\text{P-P}}$ (Note 6)		120		MHz
GBW	Gain-Bandwidth Product	$f = 200\text{kHz}$ , $R_L = 500\Omega$ $T_A = 0^\circ\text{C}$ to $70^\circ\text{C}$ $T_A = -40^\circ\text{C}$ to $85^\circ\text{C}$	● 140 ● 130 ● 120	200		MHz MHz MHz
	Gain-Bandwidth Product (Low Power Mode)	6-Lead SOT-23; $40\text{k}\Omega$ Between $\overline{\text{EN}}$ and $V^-$ ; $f = 200\text{kHz}$ , $R_L = 500\Omega$ $T_A = 0^\circ\text{C}$ to $70^\circ\text{C}$ $T_A = -40^\circ\text{C}$ to $85^\circ\text{C}$	● 35 ● 30 ● 25	55		MHz MHz MHz
-3dB BW	-3dB Bandwidth	$A_V = 1$ , $R_L = 500\Omega$		400		MHz
$t_r$ , $t_f$	Rise Time, Fall Time	$A_V = 1$ , 10% to 90%, $0.1\text{V}$ , $R_L = 100\Omega$		1.2		ns
$t_{\text{PD}}$	Propagation Delay	$A_V = 1$ , 50% to 50%, $0.1\text{V}$ , $R_L = 100\Omega$		1.5		ns
OS	Overshoot	$A_V = 1$ , $0.1\text{V}$ ; $R_L = 100\Omega$		25		%
$t_s$	Settling Time	$A_V = -1$ , 0.1%, $2\text{V}$		15		ns
THD	Total Harmonic Distortion	$A_V = 2$ , $f = 5\text{MHz}$ , $V_{\text{OUT}} = 2V_{\text{P-P}}$ , $R_L = 500\Omega$		-69		dB
dG	Differential Gain	$A_V = 2$ , $V_{\text{OUT}} = 2V_{\text{P-P}}$ , $R_L = 150\Omega$		0.08		%
dP	Differential Phase	$A_V = 2$ , $V_{\text{OUT}} = 2V_{\text{P-P}}$ , $R_L = 150\Omega$		0.13		Deg
$R_{\text{OUT}}$	Output Resistance	$A_V = -1$ , $f = 1\text{MHz}$		0.24		$\Omega$
$I_S$	Supply Current	$T_A = 0^\circ\text{C}$ to $70^\circ\text{C}$ $T_A = -40^\circ\text{C}$ to $85^\circ\text{C}$	● 6.3 ● 10 ● 11	8		mA mA mA
	Supply Current (Low Power Mode)	6-Lead SOT-23, $40\text{k}\Omega$ Between $\overline{\text{EN}}$ and $V^-$ $T_A = 0^\circ\text{C}$ to $70^\circ\text{C}$ $T_A = -40^\circ\text{C}$ to $85^\circ\text{C}$	● 1 ● 1.8 ● 2.0	1.5		mA mA mA
	Supply Current (Shutdown Mode)	6-Lead SOT-23, $\overline{\text{EN}} = V^- + 2\text{V}$ $T_A = 0^\circ\text{C}$ to $70^\circ\text{C}$ $T_A = -40^\circ\text{C}$ to $85^\circ\text{C}$	● 100 ● 175 ● 200	150		$\mu\text{A}$ $\mu\text{A}$ $\mu\text{A}$
$I_{\overline{\text{EN}}}$	$\overline{\text{EN}}$ Pin Current	6-Lead SOT-23 $T_A = 0^\circ\text{C}$ to $70^\circ\text{C}$ $T_A = -40^\circ\text{C}$ to $85^\circ\text{C}$	● -150 ● -175 ● -200	-100		$\mu\text{A}$ $\mu\text{A}$ $\mu\text{A}$
	$\overline{\text{EN}}$ Pin Current (Shutdown Mode)	6-Lead SOT-23, $\overline{\text{EN}} = V^- + 2\text{V}$ $T_A = 0^\circ\text{C}$ to $70^\circ\text{C}$ $T_A = -40^\circ\text{C}$ to $85^\circ\text{C}$	● -1.0 ● -1.5 ● -2.0	0	1.0	$\mu\text{A}$ $\mu\text{A}$ $\mu\text{A}$

**Note 1:** Absolute Maximum Ratings are those values beyond which the life of a device may be impaired.

**Note 2:** Differential inputs of  $\pm 3\text{V}$  are appropriate for transient operation only, such as during slewing. Large sustained differential inputs can cause excessive power dissipation and may damage the part.

**Note 3:** A heat sink may be required to keep the junction temperature below absolute maximum when the output is shorted indefinitely.

**Note 4:** Input offset voltage is pulse tested and is exclusive of warm-up drift.

**Note 5:** Slew rate is measured between  $\pm 2\text{V}$  at the output with  $\pm 3\text{V}$  input for  $\pm 5\text{V}$  supplies and  $2V_{\text{P-P}}$  at the output with a  $3V_{\text{P-P}}$  input for single  $5\text{V}$  supplies.

**Note 6:** Full-power bandwidth is calculated from the slew rate:

$$\text{FPBW} = \text{SR}/2\pi V_{\text{P}}$$

**Note 7:** This parameter is not 100% tested.

**Note 8:** The LT1815C is guaranteed to meet specified performance from  $0^\circ\text{C}$  to  $70^\circ\text{C}$  and is designed, characterized and expected to meet the extended temperature limits, but is not tested at  $-40^\circ\text{C}$  and  $85^\circ\text{C}$ . The LT1815I is guaranteed to meet the extended temperature limits.

**Note 9:** Thermal resistance ( $\theta_{\text{JA}}$ ) varies with the amount of PC board metal connected to the package. The specified values are for short traces connected to the leads. If desired, the thermal resistance can be substantially reduced by connecting Pin 2 of the SOT-23 or Pin 4 of the SO-8 to a large metal area.

## APPLICATIONS INFORMATION

### Layout and Passive Components

As with all high speed amplifiers, the LT1815 requires some attention to board layout. A ground plane is recommended and trace lengths should be minimized, especially on the negative input lead.

Low ESL/ESR bypass capacitors should be placed directly at the positive and negative supply (0.01 $\mu$ F ceramics are recommended). For high drive current applications, additional 1 $\mu$ F to 10 $\mu$ F tantalums should be added.

The parallel combination of the feedback resistor and gain setting resistor on the inverting input combine with the input capacitance to form a pole that can cause peaking or even oscillations. If feedback resistors greater than 1k are used, a parallel capacitor of value,

$$C_F > R_G \cdot C_{IN}/R_F$$

should be used to cancel the input pole and optimize dynamic performance. For applications where the DC noise gain is 1 and a large feedback resistor is used,  $C_F$  should be greater than or equal to  $C_{IN}$ . An example would be an I-to-V converter.

### Input Considerations

The inputs of the LT1815 amplifier are connected to the base of an NPN and PNP bipolar transistor in parallel. The base currents are of opposite polarity and provide first-order bias current cancellation. Due to variation in the matching of NPN and PNP beta, the polarity of the input bias current can be positive or negative. The offset current, however, does not depend on beta matching and is tightly controlled. Therefore, the use of balanced source resistance at each input is recommended for applications where DC accuracy must be maximized. For example, with a 100 $\Omega$  source resistance at each input, the 800nA maximum offset current results in only 80 $\mu$ V of extra offset, while without balance the 8 $\mu$ A maximum input bias current could result in a 0.8mV offset contribution.

The inputs can withstand differential input voltages of up to 6V without damage and without needing clamping or series resistance for protection. This differential input

voltage generates a large internal current (up to 80mA), which results in the high slew rate. In normal transient closed-loop operation, this does not increase power dissipation significantly because of the low duty cycle of the transient inputs. Sustained differential inputs, however, will result in excessive power dissipation and therefore **this device should not be used as a comparator**.

### Capacitive Loading

The LT1815 is stable with capacitive loads from 0pF to 100pF, which is outstanding for a 220MHz amplifier. The internal compensation circuitry accomplishes this by sensing the load induced output pole and adding compensation at the amplifier gain node as needed. As the capacitive load increases, both the bandwidth and phase margin decrease, so there will be peaking in the frequency domain and ringing in the transient response. Coaxial cable can be driven directly, but for best pulse fidelity, a resistor of value equal to the characteristic impedance of the cable (e.g. 75 $\Omega$ ) should be placed in series with the output. The receiving end of the cable should be terminated with the same value resistance to ground.

### Slew Rate

The slew rate of the LT1815 is proportional to the differential input voltage. Therefore, highest slew rates are seen in the lowest gain configurations. For example, a 5V output step in a gain of 10 has a 0.5V input step, whereas in unity gain there is a 5V input step. The LT1815 is tested for a slew rate in a gain of  $-1$ . Lower slew rates occur in higher gain configurations.

### Programmable Current and Shutdown (6-Lead SOT-23 Only)

The LT1815S6 has an enable pin ( $\overline{EN}$ , Pin 5), which is referenced to the negative supply and has an active low polarity.

In order to operate the LT1815S6 at full speed (and full supply current), pull the  $\overline{EN}$  pin down to the negative supply through an on-resistance of 75 $\Omega$  or less.



## APPLICATIONS INFORMATION

To adjust or program the supply current and speed of the LT1815S6, connect an external resistor ( $R_{\overline{EN}}$ ) between the  $\overline{EN}$  pin and the negative supply as shown in Figure 1. In this low power mode the amplifier is fully functional. Figures 2 and 3 show how the gain bandwidth and supply current vary with the value of the programming resistor  $R_{\overline{EN}}$ .

When the  $\overline{EN}$  pin is left unconnected or is forced at least 2V above the negative supply voltage, the LT1815S6 is in shutdown mode and draws only 150 $\mu$ A of supply current. The amplifier output is not isolated from the inputs, however, so the shutdown feature must not be used for multiplexing applications.

### Power Dissipation

The LT1815 combines high speed and large output drive in a small package. However, the junction temperature will not exceed the 150°C maximum unless the part is used outside of its specified drive capability. Maximum junction temperature ( $T_J$ ) is calculated from the ambient temperature ( $T_A$ ) and power dissipation ( $P_D$ ) as follows:

$$T_J = T_A + (P_D \cdot \theta_{JA}) \quad (\text{Note 9})$$

Power dissipation is composed of two parts. The first is due to the quiescent supply current and the second is due to on-chip dissipation caused by the load current. The worst-case load induced power occurs when the output voltage is at 1/2 of either supply voltage (or the maximum swing if less than 1/2 the supply voltage). Therefore  $P_{D\text{MAX}}$  is:

$$P_{D\text{MAX}} = (V^+ - V^-) \cdot (I_{S\text{MAX}}) + (V^+/2)^2/R_L \quad \text{or}$$

$$P_{D\text{MAX}} = (V^+ - V^-) \cdot (I_{S\text{MAX}}) + (V^+ - V_{O\text{MAX}}) \cdot (V_{O\text{MAX}}/R_L)$$

Example: LT1815CS5 at 70°C,  $V_S = \pm 5V$ ,  $R_L = 100\Omega$

$$P_{D\text{MAX}} = (10V) \cdot (9\text{mA}) + (2.5V)^2/100\Omega = 153\text{mW}$$

$$T_{J\text{MAX}} = 70^\circ\text{C} + (153\text{mW}) \cdot (250^\circ\text{C/W}) = 108^\circ\text{C}$$

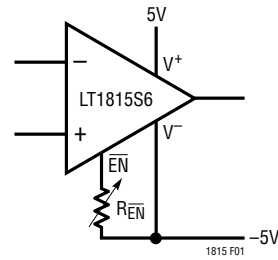

Figure 1. Programming Resistor Between  $\overline{EN}$  and  $V^-$

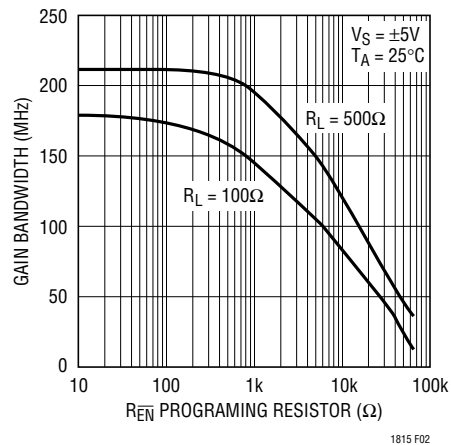

Figure 2. Gain Bandwidth vs  $R_{\overline{EN}}$  Programming Resistor

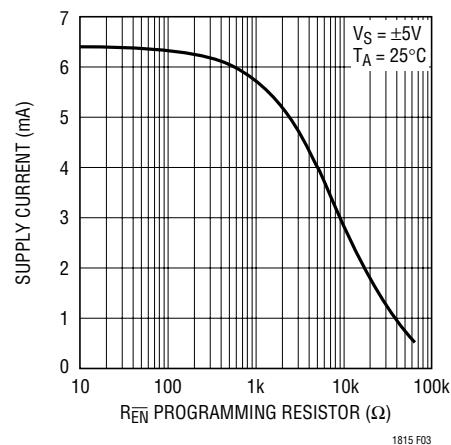

Figure 3. Supply Current vs  $R_{\overline{EN}}$  Programming Resistor



## APPLICATIONS INFORMATION

### Circuit Operation

The LT1815 circuit topology is a true voltage feedback amplifier that has the slewing behavior of a current feedback amplifier. The operation of the circuit can be understood by referring to the Simplified Schematic. Complementary NPN and PNP emitter followers buffer the inputs and drive an internal resistor. The input voltage appears across the resistor generating current that is mirrored into the high impedance node.

Complementary followers form an output stage that buffers the gain node from the load. The input resistor, input stage transconductance, and the capacitor on the high impedance node determine the bandwidth. The slew rate is determined by the current available to charge the gain node capacitance. This current is the differential input voltage divided by R1, so the slew rate is proportional to

the input step. Highest slew rates are therefore seen in the lowest gain configurations.

The RC network across the output stage is bootstrapped when the amplifier is driving a light or moderate load and has no effect under normal operation. With a heavy load (capacitive or resistive), the network is incompletely bootstrapped and adds to the compensation at the high impedance node. The added capacitance moves the unity-gain frequency away from the pole formed by the output impedance and the capacitive load. The zero created by the RC combination adds phase to ensure that the total phase lag does not exceed 180° (zero phase margin) and the amplifier remains stable. In this way, the LT1815 is stable with up to 100pF capacitive loads in unity gain, and even higher capacitive loads in higher closed-loop gain configurations.

## SIMPLIFIED SCHEMATIC

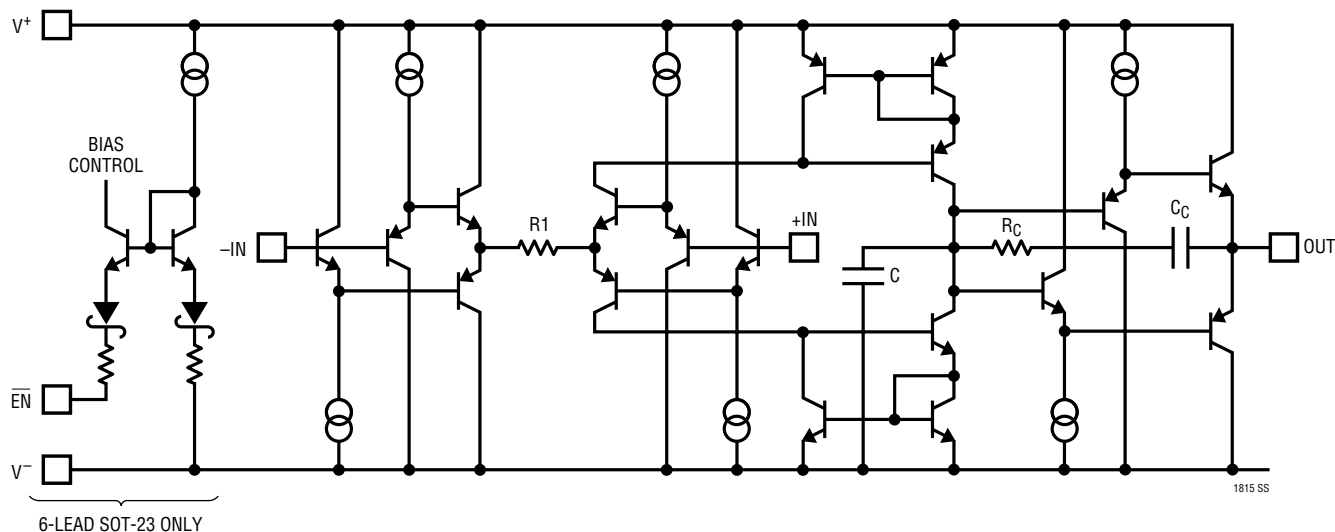

**PACKAGE DESCRIPTION** Dimensions in inches (millimeters) unless otherwise noted.

**S5 Package**  
**5-Lead Plastic SOT-23**  
 (LTC DWG # 05-08-1633)

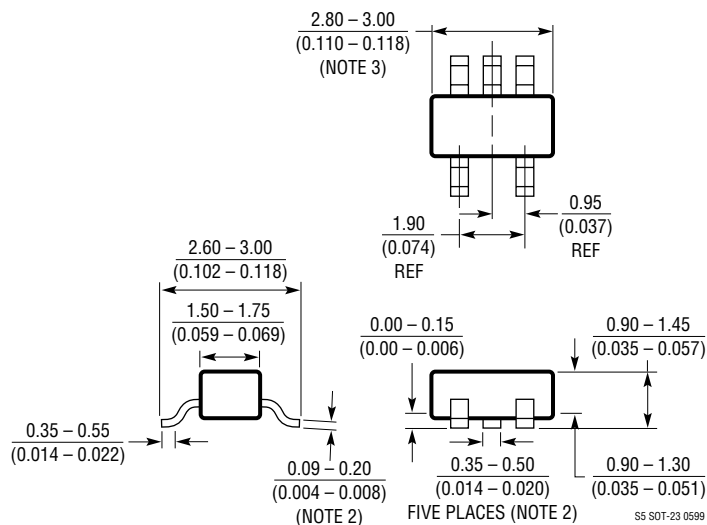

- NOTE:
1. DIMENSIONS ARE IN MILLIMETERS
  2. DIMENSIONS ARE INCLUSIVE OF PLATING
  3. DIMENSIONS ARE EXCLUSIVE OF MOLD FLASH AND METAL BURR
  4. MOLD FLASH SHALL NOT EXCEED 0.254mm
  5. PACKAGE EIAJ REFERENCE IS SC-74A (EIAJ)

**PACKAGE DESCRIPTION** Dimensions in inches (millimeters) unless otherwise noted.

**S6 Package**  
**6-Lead Plastic SOT-23**  
 (LTC DWG # 05-08-1634)

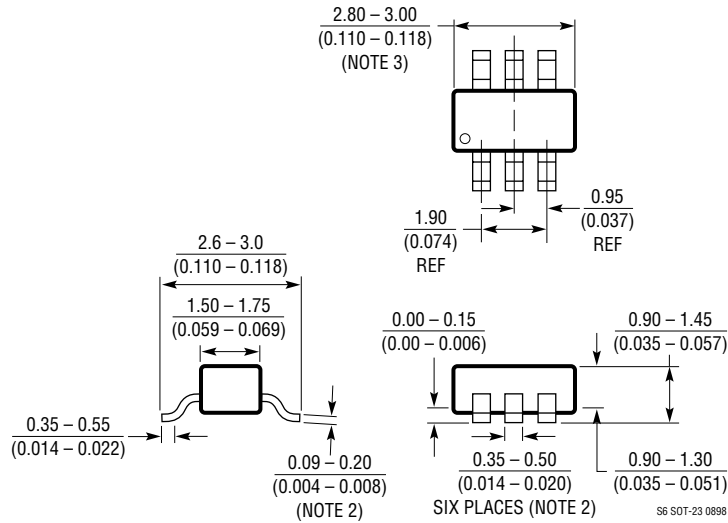

- NOTE:
1. DIMENSIONS ARE IN MILLIMETERS
  2. DIMENSIONS ARE INCLUSIVE OF PLATING
  3. DIMENSIONS ARE EXCLUSIVE OF MOLD FLASH AND METAL BURR
  4. MOLD FLASH SHALL NOT EXCEED 0.254mm
  5. PACKAGE EIAJ REFERENCE IS SC-74A (EIAJ)

**PACKAGE DESCRIPTION** Dimensions in inches (millimeters) unless otherwise noted.

**S8 Package**  
**8-Lead Plastic Small Outline (Narrow 0.150)**  
 (LTC DWG # 05-08-1610)

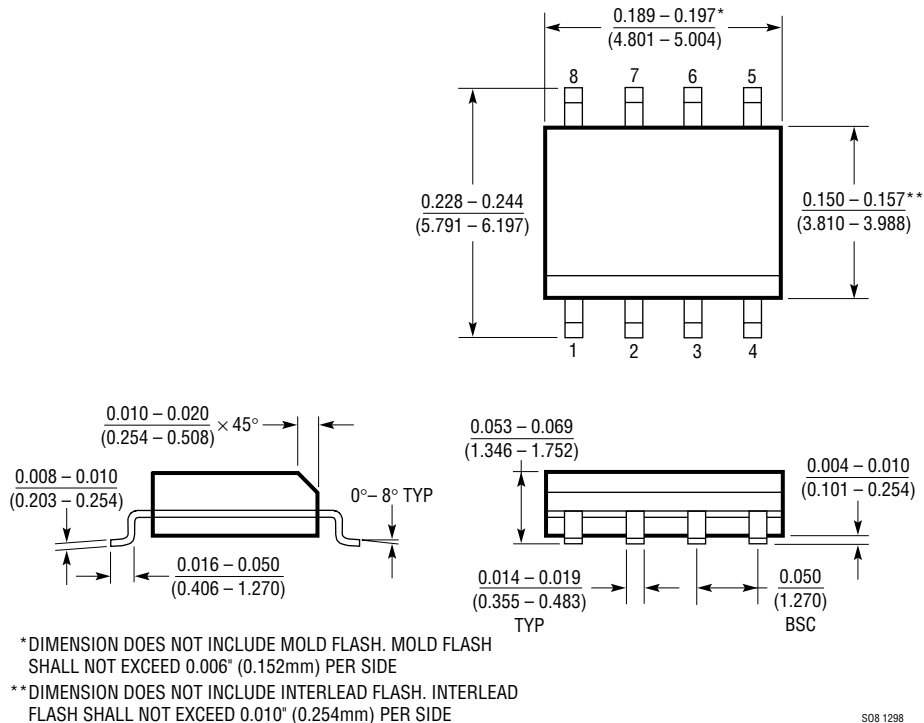

S08 1298

**RELATED PARTS**

PART NUMBER	DESCRIPTION	COMMENTS
LT1363/LT1364/LT1365	Single/Dual/Quad 70MHz, 1V/ns, C-Load™ Op Amp	Wide Supply Range: $\pm 2.5V$ to $\pm 15V$
LT1395/LT1396/LT1397	Single/Dual/Quad 400MHz Current Feedback Amplifier	4.6mA Supply Current, 800V/ $\mu s$ , 80mA Output Current
LT1806/LT1807	Single/Dual 325MHz, 140V/ $\mu s$ Rail-to-Rail I/O Op Amp	Low Noise: 3.5nV/ $\sqrt{Hz}$
LT1809/LT1810	Single/Dual 180MHz, 350V/ $\mu s$ Rail-to-Rail I/O Op Amp	Low Distortion: 90dBc at 5MHz
LT1812/LT1813	Single/Dual 3mA, 100MHz, 750V/ $\mu s$ Op Amp	Low Power LT1815

C-Load is a trademark of Linear Technology Corporation.