

EFD cores and accessories

EFD15

CORES

Effective core parameters

SYMBOL	PARAMETER	VALUE	UNIT
$\Sigma(l/A)$	core factor (C1)	2.27	mm ⁻¹
V_e	effective volume	510	mm ³
l_e	effective length	34.0	mm
A_e	effective area	15.0	mm ²
A_{min}	minimum area	12.2	mm ²
m	mass of core half	≈1.4	g

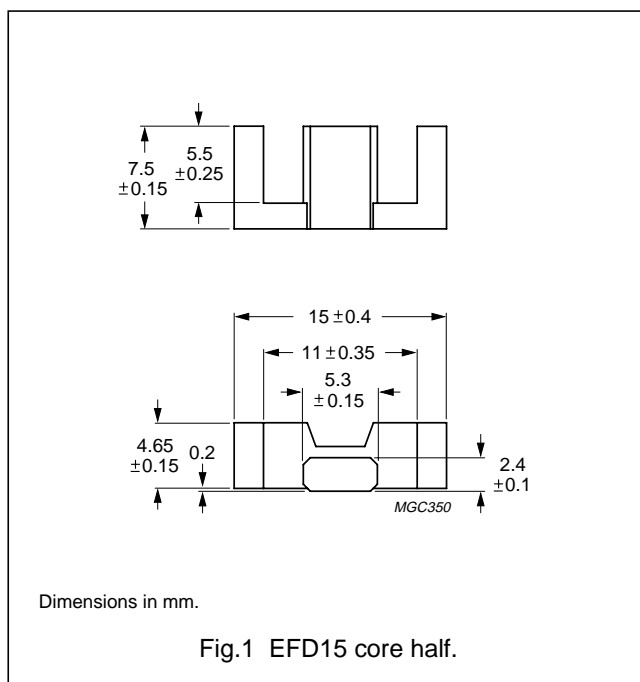

Core sets

Clamping force 20 ± 5 N.

GRADE	A_L (nH)	μ_e	AIR GAP (μm)	TYPE NUMBER
3F3	63 ± 5%	≈115	≈350	EFD15-3F3-A63-S
	100 ± 8%	≈180	≈170	EFD15-3F3-A100-S
	160 ± 10%	≈290	≈100	EFD15-3F3-A160-S
	780 ± 25%	≈1400	≈0	EFD15-3F3-S
3F4 <small>des</small>	63 ± 5%	≈115	≈350	EFD15-3F4-A63-S
	100 ± 8%	≈180	≈160	EFD15-3F4-A100-S
	160 ± 10%	≈290	≈90	EFD15-3F4-A160-S
	400 ± 25%	≈720	≈0	EFD15-3F4-S
3E4	2000 +40/-30%	≈3610	≈0	EFD15-3E4-S
3E5	3600 +40/-30%	≈6500	≈0	EFD15-3E5-S

Properties of core sets under power conditions

GRADE	B (mT) at	CORE LOSS (W) at			
	H = 250 A/m; f = 25 kHz; T = 100 °C	f = 100 kHz; \hat{B} = 100 mT; T = 100 °C	f = 400 kHz; \hat{B} = 50 mT; T = 100 °C	f = 1 MHz; \hat{B} = 30 mT; T = 100 °C	f = 3 MHz; \hat{B} = 10 mT; T = 100 °C
3F3	≥315	≤0.06	≤0.10	—	—
3F4	≥250	—	—	≤0.10	≤0.16

EFD cores and accessories

EFD15

COIL FORMERS

General data

PARAMETER	SPECIFICATION
Coil former material	phenolformaldehyde (PF), glass reinforced, flame retardant in accordance with "UL 94V-0"; UL file number E167521(M)
Pin material	copper-tin alloy (CuSn), tin-lead alloy (SnPb) plated
Maximum operating temperature	180 °C, "IEC 85" class H
Resistance to soldering heat	"IEC 68-2-20", Part 2, Test Tb, method 1B, 350 °C, 3.5 s
Solderability	"IEC 68-2-20", Part 2, Test Ta, method 1: 235 °C, 2 s

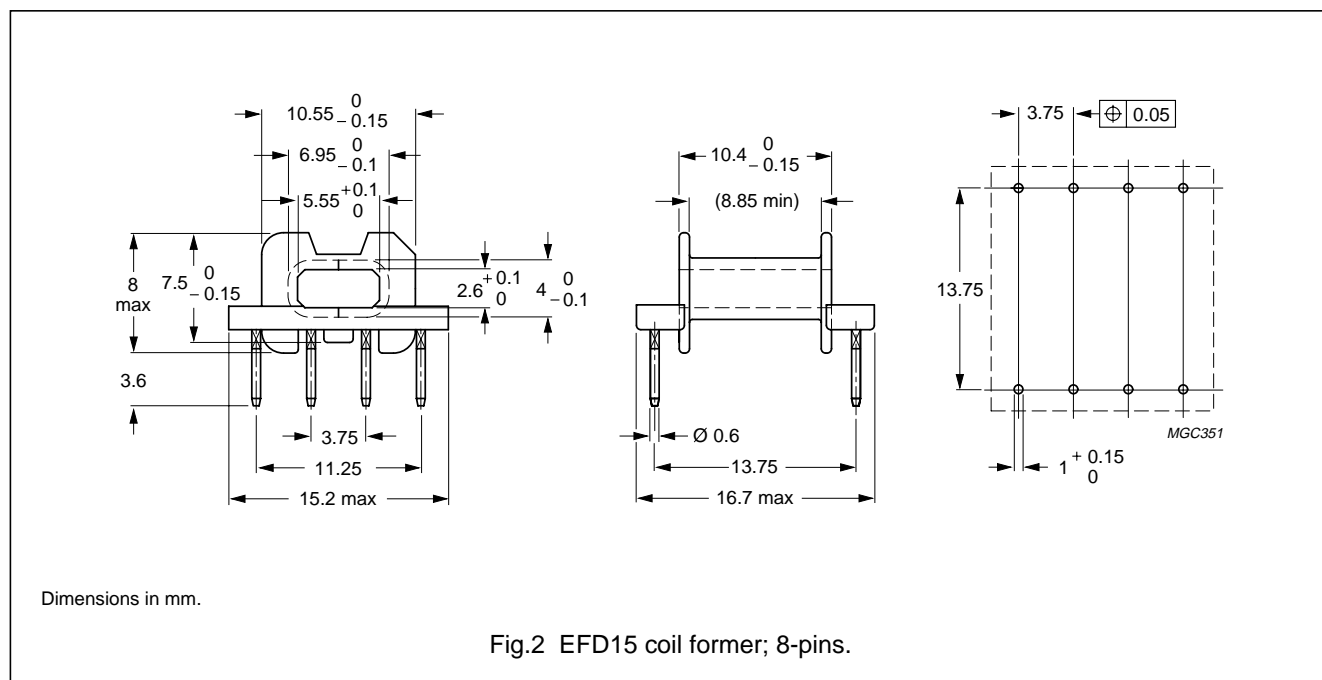

Winding data for EFD15 coil former with 8-pins

NUMBER OF SECTIONS	WINDING AREA (mm ²)	MINIMUM WINDING WIDTH (mm)	AVERAGE LENGTH OF TURN (mm)	TYPE NUMBER
1	14.8	8.85	26.3	CSH-EFD15-1S-8P

EFD cores and accessories

EFD15

COIL FORMERS

General data

PARAMETER	SPECIFICATION
Coil former material	liquid crystal polymer (LCP), glass reinforced, flame retardant in accordance with "UL 94V-0"; UL file number E83005(M)
Pin material	copper-tin alloy (CuSn), tin-lead alloy (SnPb) plated
Maximum operating temperature	155 °C, "IEC 85" class H
Resistance to soldering heat	"IEC 68-2-20", Part 2, Test Tb, method 1B, 350 °C, 3.5 s
Solderability	"IEC 68-2-20", Part 2, Test Ta, method 1: 235 °C, 2 s

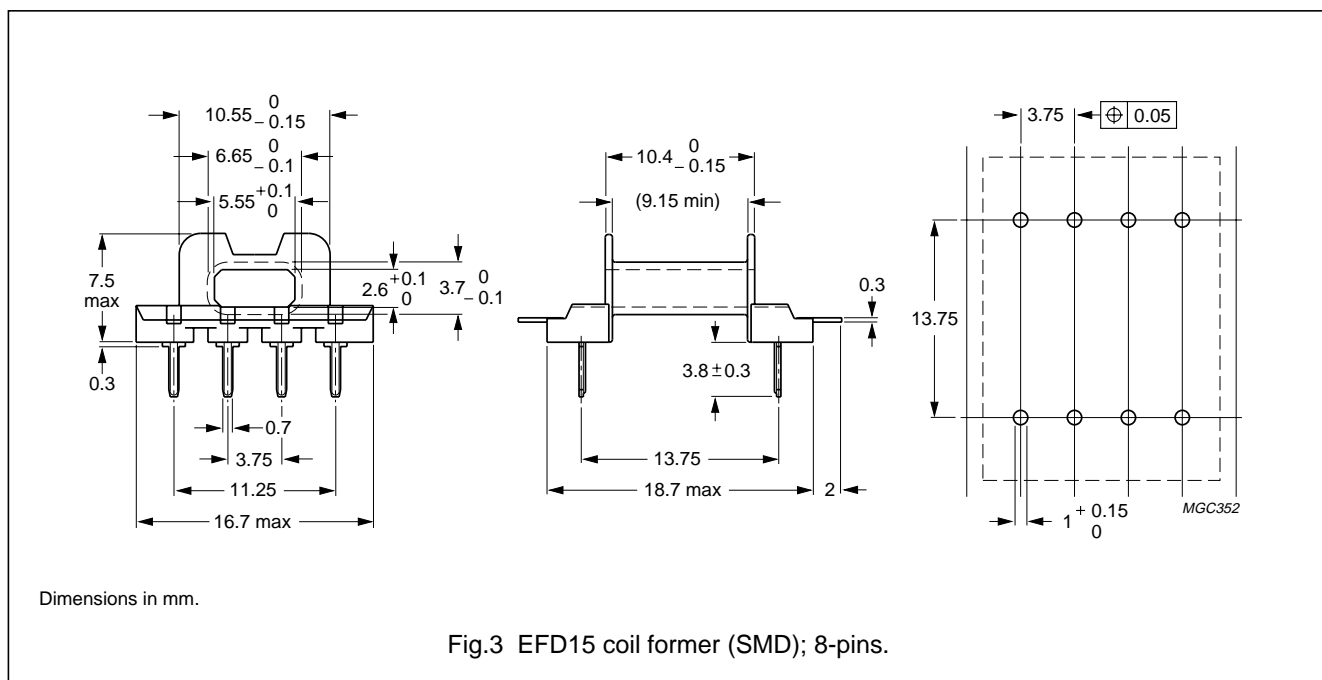

Winding data for EFD15 coil former (PCB) with 8-pins

NUMBER OF SECTIONS	WINDING AREA (mm ²)	MINIMUM WINDING WIDTH (mm)	AVERAGE LENGTH OF TURN (mm)	TYPE NUMBER
1	16.7	9.15	25.6	CPH-EFD15-1S-8P

EFD cores and accessories

EFD15

COIL FORMERS

General data

PARAMETER	SPECIFICATION
Coil former material	liquid crystal polymer (LCP), glass reinforced, flame retardant in accordance with "UL 94V-0"; UL file number E83005(M)
Solder pad material	copper-tin alloy (CuSn), tin-lead alloy (SnPb) plated
Maximum operating temperature	155 °C, "IEC 85" class F
Resistance to soldering heat	"IEC 68-2-20", Part 2, Test Tb, method 1B, 350 °C, 3.5 s
Solderability	"IEC 68-2-20", Part 2, Test Ta, method 1: 235 °C, 2 s

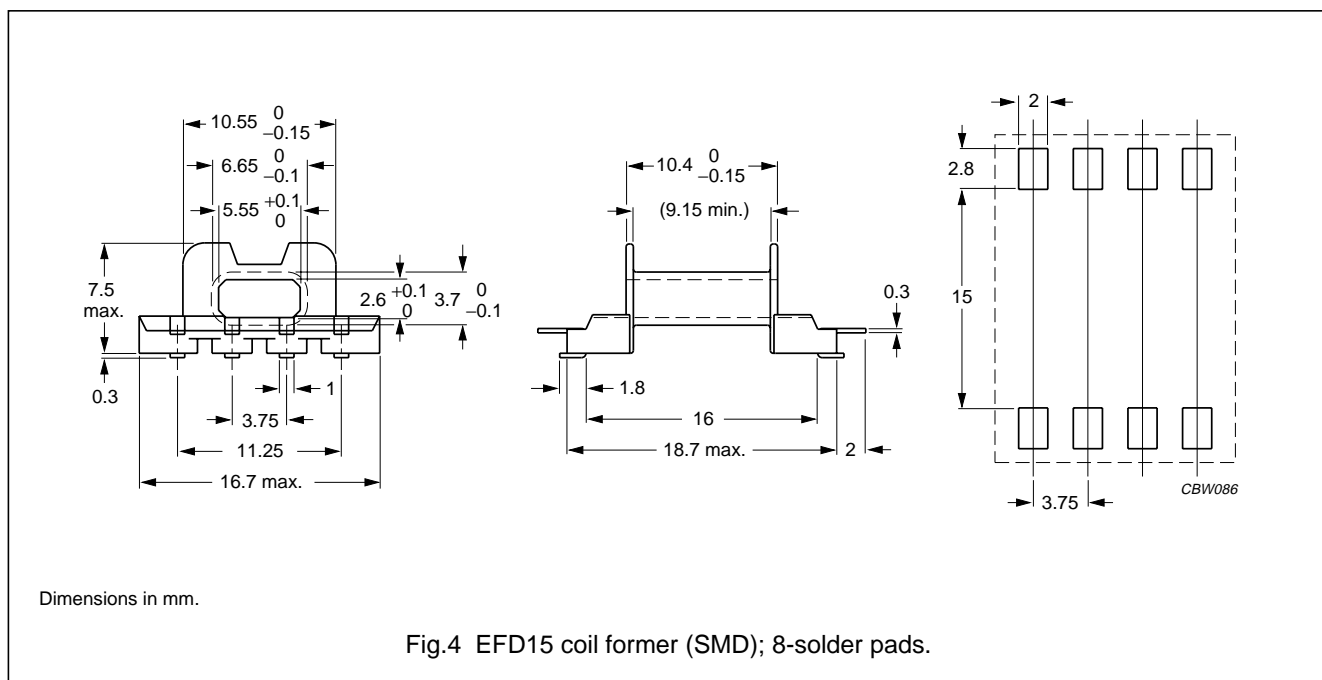

Winding data for EFD15 coil former (SMD) with 8-solder pads

NUMBER OF SECTIONS	NUMBER OF SOLDER PADS	WINDING AREA (mm ²)	MINIMUM WINDING WIDTH (mm)	AVERAGE LENGTH OF TURN (mm)	TYPE NUMBER
1	8	16.7	9.15	25.6	CPHS-EFD15-1S-8P

EFD cores and accessories

EFD15

MOUNTING PARTS

General data

ITEM	REMARKS	FIGURE	TYPE NUMBER
Clip	stainless steel (CrNi); clamping force ≈ 12.5 N	6	CLI-EFD15
Clamp	stainless steel (CrNi); clamping force ≈ 25 N	5	CLM-EFD15

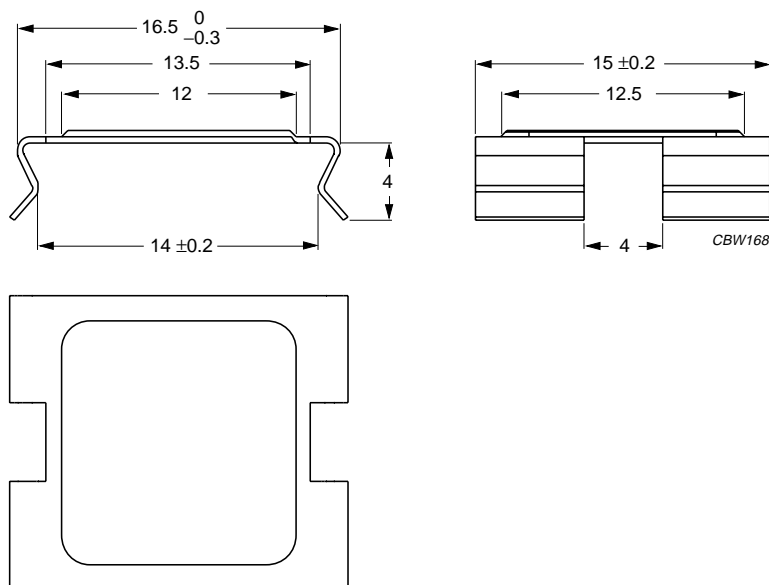

Dimensions in mm.

Fig.5 Clamp CLM-EFD15.

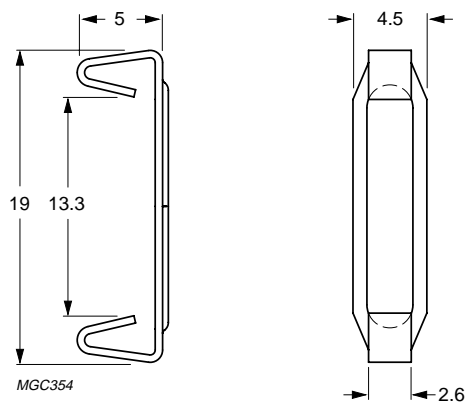

Dimensions in mm.

Fig.6 Clip CLI-EFD15.