

**ADVANCED ANALOG
HYBRID-HIGH RELIABILITY
DC/DC CONVERTERS**

AHE28XXS SERIES
28V Input, Single Output

Description

The AHE28XXS Series of DC/DC converters feature high power density and an extended temperature range for use in military and industrial applications. Designed to MIL-STD-704D input requirements, these devices have nominal 28VDC inputs with +5V, +12V and +15V single outputs to satisfy a wide range of requirements. The circuit design incorporates a pulse width modulated push-pull topology operating in the feed-forward mode at a nominal switching frequency of 250KHz. Input to output isolation is achieved through the use of transformers in the forward and feedback circuits.

The advanced feedback design provides fast loop response for superior line and load transient characteristics and offers greater reliability and radiation tolerance than devices incorporating optical feedback circuits.

Three standard temperature grades are offered with screening options. Refer to Part Number section. They can be provided in a standard plug-in package for PC mounting or in a flanged package for more severe environments.

These converters are manufactured in a facility certified to MIL-PRF-38534. All processes used to manufacture these converters have been qualified to enable Advanced Analog to deliver compliant devices.

Two screening grades are available to satisfy a wide range of requirements. The CH grade converters are fully compliant to MIL-PRF-38534 for class H. The HB grade converters are processed to full class H screening but do not have class H element evaluation as required by MIL-PRF-38534. Both grades are fully tested and operate over the full military temperature range without derating of output power. Variations in electrical, mechanical and screening can be accommodated.



Features

- 17 to 40 VDC Input Range (28 VDC Nominal)
- 5V, 12V and 15V Outputs Available
- Indefinite Short Circuit and Overload Protection
- 17 W/in³ Power Density
- 15 and 20 Watts Output Power Models
- Fast Loop Response for Superior Transient Characteristics
- Operating Temperature Range from -55°C to +125°C Available
- Popular Industry Standard Pin-Out
- Resistance Seam Welded Case for Superior Long Term Hermeticity
- Efficiencies up to 84%
- Shutdown from External Signal
- Military Screening
- 325,000 hour MTBF at 85°C (AUC)

Extensive computer simulation using complex modeling enables rapid design modification to be provided. Contact Advanced Analog with specific requirements.

Specifications

T_{CASE} = -55°C to +85°C, V_{IN} = +28V ± 5% unless otherwise specified

ABSOLUTE MAXIMUM RATINGS	
Input Voltage ¹	-0.5V to 50V
Power Output	Internally limited, 17.5W typical for AHE2805S, 22.5W typical for AHE2812S and AHE2815S
Soldering	300°C for 10 seconds
Temperature Range ¹	Operating -55°C to +125°C case Storage -65°C to +135°C

Parameter	Conditions -55°C ≤ T _c ≤ +85°C V _{in} = 28 Vdc ±5%, C _L = 0 Unless otherwise specified	AHE2805S			AHE2812S			AHE2815S			Units
		Min	Typ	Max	Min	Typ	Max	Min	Typ	Max	
Static Characteristic											
OUTPUT											
Voltage	V _{IN} =17 to 40 VDC	4.90	5.00	5.10	11.76	12.00	12.24	14.70	15.00	15.30	VDC
Current	I _{OUT} =0 to Full Load	0.0		3000	0.0		1667	0.0		1333	mADC
Ripple	Full Load, DC to 1MHz T _{CASE} = 25°C, I _{OUT} = 0		20	60		30	60		30	60	mVp-p
Accuracy		4.95	5.00	5.05	11.88	12.00	12.12	14.85	15.00	15.15	VDC
Power ¹		15			20			20			W
REGULATION											
Line	V _{IN} = 17 to 40 VDC		±0.5	±1.0		±0.5	±1.0		±0.5	±1.0	%
Load	I _{OUT} = to Full Load		±0.5	±1.0		±0.5	±1.0		±0.5	±1.0	%
INPUT											
Voltage Range ⁴	Inhibited	17.0	28.0	40.0	17.0	28.0	40.0	17.0	28.0	40.0	VDC
Current	No Load		8	18		8	18		8	18	mADC
	Full Load			35			35			35	mADC
Ripple Current			20	50		25	50		25	50	mV p-p
Efficiency	T _{CASE} = +25°C Half Load to Full Load	80	82		79	83		80	84		%
Capacitive Load	No effect on performance	500			200			200			µF
Load fault power dissipation ¹				6			6			6	W
Isolation	Input to Output @ 500Vdc	100			100			100			MΩ
Dynamic Characteristic											
Step Load Changes											
Output	50% Load 100% Load		±150			±200			±200		mVpk
Transient	No Load 50% Load		-300			-400			-400		mVpk
	50% Load No Load		+300			+400			+400		mVpk
Recovery ²	50% Load 100% Load		25			25			25		µsec
	No Load 50% Load		500			500			500		µsec
	50% Load No Load		7			7			7		msec
Step Line Changes											
Output											
Transient	Input step 17 to 40VDC		+180			+180			+180		mVpk
Recovery ²	Input step 40 to 17VDC		-600			-600			-600		mVpk
	Input step 17 to 40VDC		400			400			400		µsec
	Input step 40 to 17VDC		400			400			400		µsec
Turn-On											
Overshoot Delay ³	V _{IN} = 17 to 40VDC I _{OUT} = 0 to Full load		0	500		300	600		300	500	mVpk msec
			8	14		8	14		8	14	msec
Load Fault											
Recovery ⁴	V _{IN} = 17 to 40VDC		8	14		8	14		8	14	msec
Weight											
	Standard Package		55			55			55		grams
	Flange Package		58			58			58		grams

Notes to Specifications

- Above +85°C case temperature, derate output power linearly to 0 and maximum input voltage linearly to 42V at 115°C case.
- Recovery time is measured from the initiation of the transient to where V_{OUT} has returned to within ±1% of V_{OUT} at 50% load. See typical waveforms.
- Turn-on delay time measurement is for either an application of power at the input or a signal at the shutdown pin.
- For operation at 16VDC, derate output power by 33%.

Specifications

$T_{CASE} = -55^{\circ}\text{C}$ to $+105^{\circ}\text{C}$, $V_{IN} = +28\text{V} \pm 5\%$ unless otherwise specified

ABSOLUTE MAXIMUM RATINGS	
Input Voltage ⁵	-0.5V to 50V
Power Output	Internally limited, 17.5W typical for AHE2805S/ES, 22.5W typical for AHE2812S/ES and AHE2815S/ES
Soldering	300°C for 10 seconds
Temperature Range ¹	Operating -55°C to +125°C case Storage -65°C to +135°C

Parameter	Conditions -55°C ≤ Tc ≤ +105°C Vin = 28 Vdc ±5%, CL = 0 Unless otherwise specified	AHE2805S/ES			AHE2812S/ES			AHE2815S/ES			Units
		Min	Typ	Max	Min	Typ	Max	Min	Typ	Max	
Static Characteristic											
OUTPUT											
Voltage	V _{IN} = 17 to 40 VDC	4.90	5.00	5.10	11.76	12.00	12.24	14.70	15.00	15.30	VDC
Current	I _{OUT} = 0 to Full Load	0.0		3000	0.0		1667	0.0		1333	mADC
Ripple	Full Load, DC to 1MHz T _{CASE} = 25°C, I _{OUT} = 0		20	60		30	60		30	60	mVp-p
Accuracy		4.95	5.00	5.05	11.88	12.00	12.12	14.85	15.00	15.15	VDC
Power ¹		15			20			20			W
REGULATION											
Line	V _{IN} = 17 to 40 VDC		±0.5	±1.0		±0.5	±1.0		±0.5	±1.0	%
Load	I _{OUT} = 0 to Full Load		±0.5	±1.0		±0.5	±1.0		±0.5	±1.0	%
INPUT											
Voltage Range ⁴		17.0	28.0	40.0	17.0	28.0	40.0	17.0	28.0	40.0	VDC
Current	Inhibited		8	18		8	18		8	18	mADC
	No Load			35			35			35	mADC
	Full Load		20	50		25	50		25	50	mV p-p
Ripple Current											
Efficiency	T _{CASE} = +25°C Half load to Full load	78	82		79	83		80	84		%
Capacitive Load	No effect on performance	500			200			200			µF
Load fault power dissipation ⁴				6			6			6	W
Isolation	Input to Output @ 500Vdc	100			100			100			MΩ
Dynamic Characteristic											
Step Load Changes											
Output	50% Load 100% Load		±150			±200			±200		mVpk
Transient	No Load 50% Load		-300			-400			-400		mVpk
	50% Load No Load		+300			+400			+400		mVpk
Recovery ²	50% Load 100% Load		25			25			25		µsec
	No Load 50% Load		500			500			500		µsec
	50% Load No Load		7			7			7		msec
Step Line Changes											
Output	Input step 17 to 40VDC		+180			+180			+180		mVpk
Transient	Input step 40 to 17VDC		-600			-600			-600		mVpk
Recovery ²	Input step 17 to 40VDC		400			400			400		µsec
	Input step 40 to 17VDC		400			400			400		µsec
TURN -ON											
Overshoot	V _{IN} = 17 to 40VDC		0	500		300	600		300	750	mVpk
Delay ³	I _{OUT} = 0 to Full Load		8	14		8	14		8	14	msec
Load Fault Recovery ⁴	V _{IN} = 17 to 40VDC		8	14		8	14		8	14	msec
Weight	Standard Package		60			60			60		grams
	Flange Package		65			65			65		grams

Notes to Specifications

- Above +105°C case temperature, derate output power linearly to 0 at 125°C case.
- Recovery time is measured from the initiation of the transient to where V_{OUT} has returned to within ±1% of V_{OUT} at 50% load. See typical waveforms.
- Turn-on delay time measurement is for either an application of power at the input or a signal at the shutdown pin.
- For operation at 16VDC, derate output power by 33%.
- Above +85°C case temperature, derate maximum input voltage linearly to 33V at +125°C case.

Specifications

ABSOLUTE MAXIMUM RATINGS	
Input Voltage ¹	-0.5V to 50V
Power Output	Internally limited, 17.5W typical for AHE2805S/HB&CH, 22.5W typical for AHE281XS/HB&CH
Soldering	300°C for 10 seconds
Temp Range ¹	Operating -55°C to +125°C case Storage -65°C to +135°C

Parameter	Conditions -55°C ≤ T _c ≤ +125°C V _{in} = 28 Vdc ±5%, C _L = 0 Unless otherwise specified	AHE2805S/HB&CH			AHE2812S/HB&CH			AHE2815S/HB&CH			Units
		Min	Typ	Max	Min	Typ	Max	Min	Typ	Max	
Static Characteristic											
OUTPUT	V _{in} =17 to 40 VDC I _{OUT} =0 to Full Load Full Load, DC to 1MHz T _{CASE} = 25°C, I _{OUT} = 0	4.90	5.00	5.10	11.76	12.00	12.24	14.70	15.00	15.30	VDC
Voltage		0.0		3000	0.0		1667	0.0		1333	mADC
Current			20	60	30	60	30	30	60	60	mVp-p
Ripple			4.95	5.00	5.05	11.88	12.00	12.12	14.85	15.00	15.15
Accuracy		15			20			20			W
Power ¹											
REGULATION	V _{in} = 17 to 40 VDC T _{CASE} = 25°C I _{OUT} = 0 to Full Load			5			30			35	mV
Line		10		50	50		120	50		150	mV
Load											
INPUT	Inhibited No Load Full Load	17.0	28.0	40.0	17.0	28.0	40.0	17.0	28.0	40.0	VDC
Voltage Range ⁴			8	18		8	18		8	18	mADC
Current			20	35	50	25	35	50	25	35	50
Ripple Current											mV p-p
Efficiency	T _{CASE} = +25°C	80	82		80	83		80	84		%
Capacitive Load	No effect on performance	500	1000		200	1000		200	1000		µF
Load fault power dissipation ⁵	Short Circuit T _c = 25°C Overload T _c = 25°C			4.5 6			4.5 6			4.5 6	W W
Isolation	Input to Output @ 500Vdc	100			100			100			MΩ
Dynamic Characteristic	50% Load 100% Load No Load 50% Load 50% Load No Load 50% Load 100% Load No Load 50% Load 50% Load No Load		±150	±300		±200	±300		±200	±300	mVpk
Step Load Changes			-300	-500		-400	-500		-400	-500	mVpk
Output T _c = 25°C			+300	+500		+400	+500		+400	+500	mVpk
Transient			25	70		25	70		25	70	µsec
Recovery ²		100	200	5	500	1500	5	500	1500	µsec	
Step Line Changes	Input step 17 to 40VDC Input step 40 to 17VDC Input step 17 to 40VDC Input step 40 to 17VDC		+180	+300		+180	+500		+180	+500	mVpk
Output T _c = 25°C			-600	1000		-600	-1500		-600	-1500	mVpk
Transient			400	800		400	800		400	800	µsec
Recovery ²			400	800		400	800		400	800	µsec
TURN -ON	V _{in} = 17 to 40VDC I _{OUT} = 0 to Full Load		0	550		300	600		300	500	mVpk
Overshoot			8	10		8	10		8	10	msec
Delay ³			8	10		8	10		8	10	msec
Load Fault Recovery ⁴	V _{in} = 17 to 40VDC		8	10		8	10		8	10	msec
Weight	Standard Package		55			55			55		grams
	Flange Package		58			58			58		grams

Notes to Specifications

- Above +125°C case temperature, derate output power linearly to 0 at 135°C case.
- Recovery time is measured from the initiation of the transient to where V_{OUT} has returned to within ±1% of V_{OUT} at 50% load. See typical waveforms.
- Turn-on delay time measurement is for either an application of power at the input or a signal at the shutdown pin.
- For operation at 16VDC, derate output power by 33%.
- An overload is that condition with a load in excess of the rated load but less than that necessary to trigger the short circuit protection and is the condition of maximum power dissipation.

AHE28XXS Block Diagram

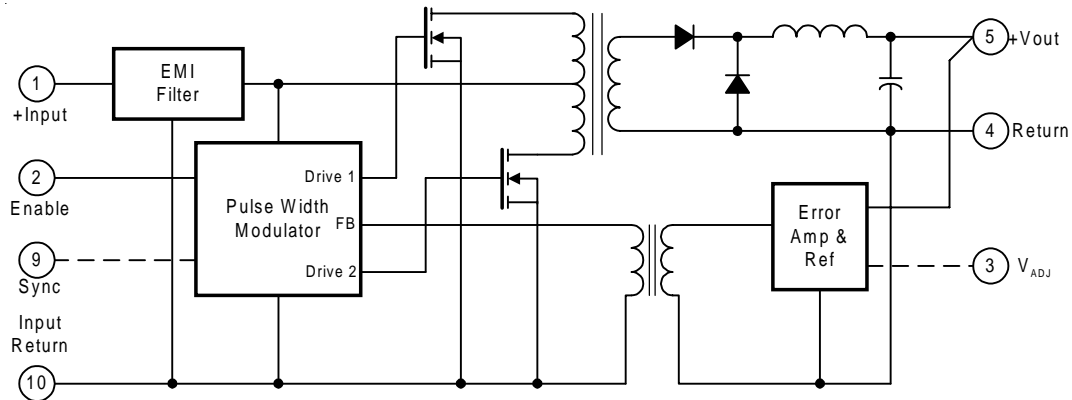

Application Information

Inhibit Function

Connecting the inhibit input (Pin 2) to input common (Pin 10) will cause the converter to shut down. It is recommended that the inhibit pin be driven by an open collector device capable of sinking at least 400 μ A of current. The open circuit voltage of the inhibit input is 11.5 \pm 1 VDC.

EMI Filter

An EMI filter (AFC461), available as an option, will reduce the input ripple current to levels below the limits imposed by MIL-STD-461B CEO.

Output Voltage Adjustment (AHE2805 only)

The output voltage of the AHE2805S converter can be adjusted upward by connecting an appropriate resistor between Output Adjust (Pin 3) and Output Common (Pin 4) as shown in Table 1 below.

Table 1 Output adjustment resistor values

Resistance Pin 3 to 4 (Ω)	Output Voltage Increases (%)
None	0
390K	+1%
145K	+2%
63K	+3%
22K	+4%
0	+5%

Device Synchronization

Whenever multiple DC/DC converters are utilized in a single system, significant low frequency noise may be generated due to slight difference in the switching frequencies of the converters (beat frequency noise). Because of the low frequency nature of this noise (typically less than 10KHz), it is difficult to filter out and may interfere with proper operation of sensitive systems (communications, radar or telemetry). Advanced Analog offers an option, which provides synchronization of multiple AHE/ATW/ATO type converters, thus eliminating this type of noise.

To take advantage of this capability, the system designer must assign one of the converters as the master. Then, by definition, the remaining converters become slaves and will operate at the masters' switching frequency.

The user should be aware that the synchronization system is fail-safe; that is, the slaves will continue operating should the master frequency be interrupted for any reason. The layout must be such that the synchronization output (pin 9) of the master device is connected to the synchronization input (pin 9) of each slave device. It is advisable to keep this run short to minimize the possibility of radiating the 250KHz switching frequency.

The appropriate parts must be ordered to utilize this feature. After selecting the converters required for the system, a MSTR suffix is added for the master converter part number and a SLV suffix is added for slave part number. See Part Number section.

Typical Synchronization Connection

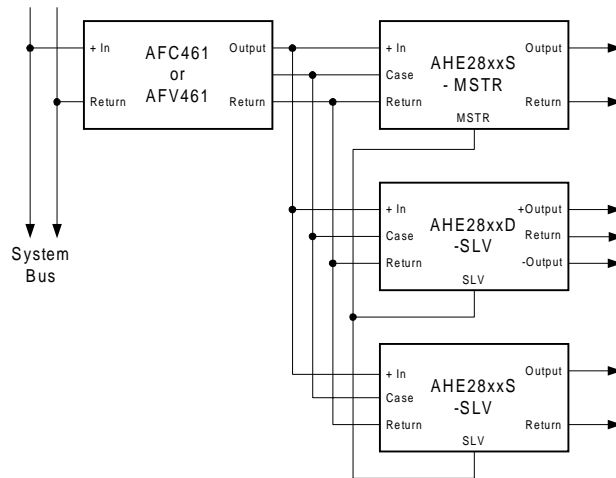

AHE28XXS Case Outlines

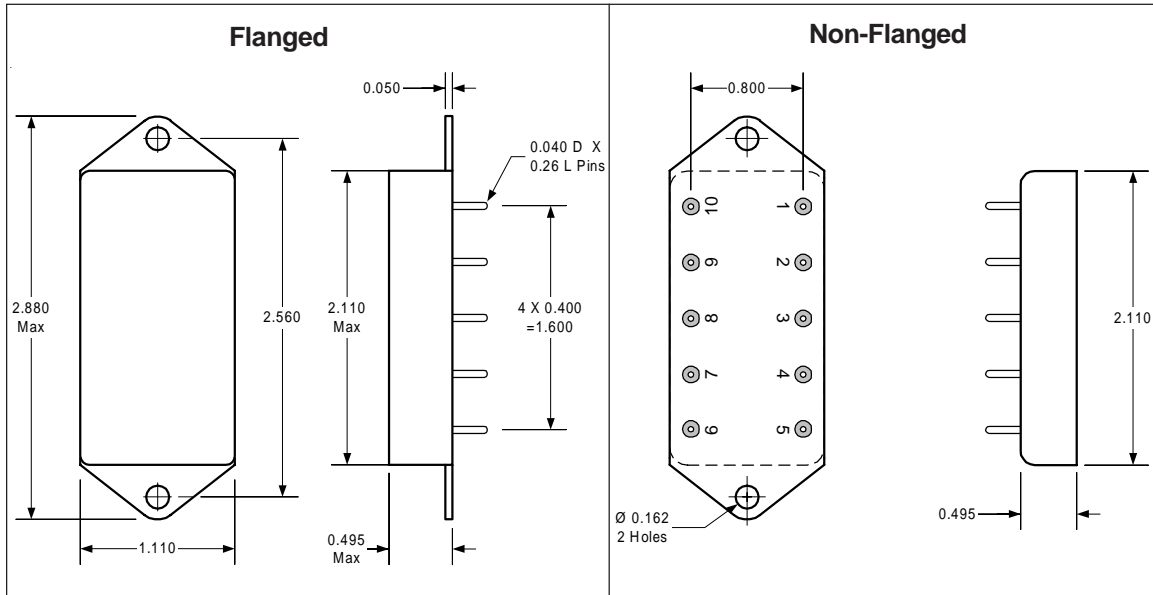

Pin Designation

Pin No.	Designation
1	Positive Input
2	Enable Input
3	Output Adjust *
4	Output Return
5	Positive Output
6	N/C
7	N/C
8	Case Ground
9	N/C or Sync.
10	Input Return

* AHE2805S only. AHE2812S / 2815S have N/C on Pin 3

Part Numbering

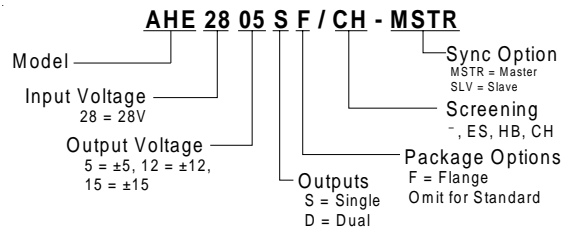

Available Screening Levels and Process Variations for AHE28XXS Series

Requirement	MIL-STD-883 Method	No Suffix	ES Suffix	HB Suffix	CH Suffix
Temperature Range		-20 to +85°C	-55°C to +125°C	-55°C to +125°C	-55°C to +125°C
Element Evaluation					MIL-PRF-38534
Internal Visual	2017	*	Yes	Yes	Yes
Temperature Cycle	1010		Cond B	Cond C	Cond C
Constant Acceleration	2001		500g	Cond A	Cond A
Burn-in	1015	48hrs @ 85°C	48hrs @ 125°C	160hrs @ 125°C	160hrs @ 125°C
Final Electrical (Group A)	MIL-PRF-38534 & Specifications	25°C	25°C	-55, +25, +125°C	-55, +25, +125°C
Seal, Fine & Gross	1014	Cond C	Cond A, C	Cond A, C	Cond A, C
External Visual	2009	*	Yes	Yes	Yes

* Per Commercial Standards

Available Standard Military Drawing (SMD) Cross Reference

Standard Military Drawing PIN	Vendor CAGE Code	Vendor Similar PIN	Standard Military Drawing PIN	Vendor CAGE Code	Vendor Similar PIN
5962-8968301HXX	52467	AHE2805S/CH	5962-9158001HXX	52467	AHE2812S/CH
5962-8968301HZX	52467	AHE2805SF/CH	5962-9158001HZX	52467	AHE2812SF/CH
5962-8968302HXX	52467	AHE2805S/CH-SLV	5962-9158002HXX	52467	AHE2812S/CH-SLV
5962-8968302HZX	52467	AHE2805SF/CHSLV	5962-9158002HZX	52467	AHE2812SF/CH-SLV
5962-8968303HXX	52467	AHE2805S/CH-MSTR	5962-9158003HXX	52467	AHE2812S/CH-MSTR
5962-8968303HZX	52467	AHE2805SF/CH-MSTR	5962-9158003HZX	52467	AHE2812SF/CH-MSTR

Standard Military Drawing PIN	Vendor CAGE Code	Vendor Similar PIN
5962-9162501HXX	52467	AHE2815S/CH
5962-9162501HZX	52467	AHE2815SF/CH
5962-9162502HXX	52467	AHE2815S/CH-SLV
5962-9162502HZX	52467	AHE2815SF/CH-SLV
5962-9162503HXX	52467	AHE2815S/CH-MSTR
5962-9162503HZX	52467	AHE2815SF/CH-MSTR