

## DC-DC Converters 1 and 2 Watt

ICR 1: 1 or 2 outputs  
 IWR 1: 1 to 4 outputs  
 IWR 2: 1 output

with input to output isolation

with input filter

Input : 5, 12, 15, 24, 28, 48 V DC

Outputs: 5, 12, 15 V DC

Combinations of output voltages  
 see Block Diagrams page 5  
 and Type Survey page 3

### Description

The DC-DC converters have been developed as a response to the increasing need for decentralised power supply systems. They are especially suitable to power small loads on pcbs. At the same time they are an ideal element to realize redundant systems. The DC-DC converters feature low output ripple, low module height, high quality and reliability. To minimize feedback effects in the supply system, the modules are equipped with a low-pass input filter.

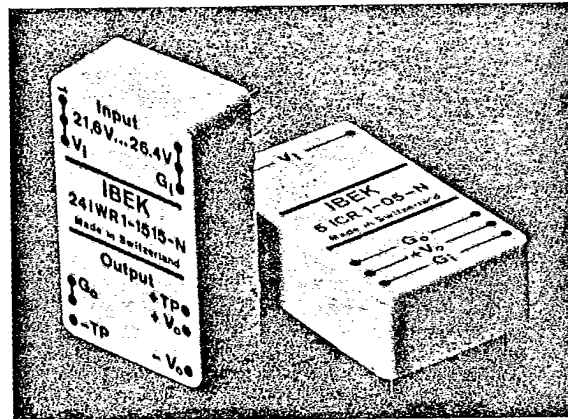

### Features

- Input filter
- High efficiency (typ 58 %)
- High reliability
- Optimal dynamic characteristics
- Height of 10.5 mm only
- No derating

### Benefits

- low noise level
- low heat generation
- MTBF = 350 000 h ( $T_A = +40\text{ }^\circ\text{C}$ ,  $G_F$ )
- excellent dynamic load behaviour
- compact circuitry and system design
- full load capability over the specified ambient temperature range

### Applications

Power supply for Op-Amps, A/D- and D/A-converters  
 Power supply for  $\mu$ Ps, RAMs, PROMs, opto-electronic systems

### Type Designation Key

Example:

24 IWR 1-2x0505-N

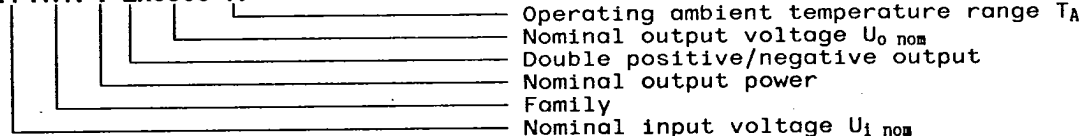

Type Survey

U <sub>i</sub> nom	Typ	U <sub>o1</sub> nom	I <sub>o1</sub> nom	U <sub>o2</sub> nom	I <sub>o2</sub> nom	Group <sup>5)</sup>
12 V	12 IWR 2-12-. <sup>4)</sup>	12 V	167 mA	-	-	01
15 V	15 IWR 2-15-. <sup>4)</sup>	15 V	133 mA	-	-	
5 V	.. IWR 1-05-. <sup>3)</sup>	5 V	200 mA	-	-	02
	.. IWR 1-12-. <sup>1)</sup>	12 V	80 mA	-	-	
	.. IWR 1-15-. <sup>1)</sup>	15 V	66 mA	-	-	
	.. IWR 1-0505-. <sup>1)</sup>	± 5 V	±50 mA	-	-	
12 V	.. IWR 1-1205-. <sup>1)</sup>	+12 V/-5 V	±40 mA	-	-	03
	.. IWR 1-1212-. <sup>1)</sup>	±12 V	±40 mA	-	-	
	.. IWR 1-1515-. <sup>1)</sup>	±15 V	±33 mA	-	-	
	.. IWR 1-05-05-. <sup>3)</sup>	5 V	100 mA	5 V	100 mA	
24 V	.. IWR 1-05-12-. <sup>3)</sup>	5 V	100 mA	12 V	40 mA	04
	.. IWR 1-05-15-. <sup>3)</sup>	5 V	100 mA	15 V	33 mA	
	.. IWR 1-12-12-. <sup>1)</sup>	12 V	40 mA	12 V	40 mA	
	.. IWR 1-15-15-. <sup>1)</sup>	15 V	33 mA	15 V	33 mA	
28 V	.. IWR 1-05-1212-. <sup>1)4)</sup>	5 V	40 mA	±12 V	±33 mA	05
	.. IWR 1-12-1212-. <sup>1)2)4)</sup>	12 V	28 mA	±12 V	±28 mA	
	.. IWR 1-15-1212-. <sup>1)2)4)</sup>	15 V	26 mA	±12 V	±26 mA	
	.. IWR 1-05-1515-. <sup>1)4)</sup>	5 V	40 mA	±15 V	±26 mA	
48 V <sup>4)</sup>	.. IWR 1-12-1515-. <sup>1)2)4)</sup>	12 V	24 mA	±15 V	±24 mA	06
	.. IWR 1-15-1515-. <sup>1)2)4)</sup>	15 V	22 mA	±15 V	±22 mA	
	.. IWR 1-2x0505-. <sup>4)</sup>	± 5 V	±50 mA	± 5 V	±50 mA	
	.. IWR 1-2x1212-. <sup>1)2)4)</sup>	±12 V	±20 mA	±12 V	±20 mA	
48 V <sup>4)</sup>	.. IWR 1-2x1515-. <sup>1)2)4)</sup>	±15 V	±17 mA	±15 V	±17 mA	07
	.. ICR 1-05-. <sup>3)</sup>	5 V	200 mA	-	-	
	.. ICR 1-12-. <sup>1)</sup>	12 V	80 mA	-	-	
	.. ICR 1-15-. <sup>1)</sup>	15 V	66 mA	-	-	
48 V <sup>4)</sup>	.. ICR 1-1212-. <sup>1) 2)</sup>	±12 V	±40 mA	-	-	08
	.. ICR 1-1515-. <sup>1) 2)</sup>	±15 V	±33 mA	-	-	
48 V <sup>4)</sup>	.. ICR 1-12-12-. <sup>1)</sup>	12 V	40 mA	12 V	40 mA	08
	.. ICR 1-15-15-. <sup>1)</sup>	15 V	33 mA	15 V	33 mA	

.. see Type Designation Key page 2 and table below

Maximum Ratings

Characteristic	5I.1	12I.1	12I.2	15I.2	24I.1	28I.1	48I.1
Admissible input voltage U <sub>i</sub> abs without defect (max 60 s)	min 0 V max 6.25V	0 V 15 V	0 V 15 V	0 V 16 V	0 V 30 V	0 V 35 V	0 V 60 V
Operating input voltage U <sub>i</sub>	min 4.75V max 5.25V	10.8V 13.2V	11.9V 12.1V	14.9V 15.1V	21.6V 26.4V	25.2V 30.8V	43.2V 52.8V
Storage temperature T <sub>s</sub>	suffix N -40 °C...+85 °C suffix T -40 °C...+105 °C suffix S -55 °C...+105 °C						
Operating ambient temperature T <sub>A</sub>	suffix N 0 °C...+71 °C suffix T -25 °C...+71 °C suffix S -40 °C...+85 °C						

- The Output current of one output may be increased by 25 % if the output current of the other output is reduced by 25 % at the same time.  
Example: 5 IWR 1-1515-N  
The output current of 33 mA at +15 V may be increased to 41 mA if the -15 V output is reduced to 25 mA.
- The output current of both outputs of the 12, 24, 28 and 48 V input types may be increased by 20 % of I<sub>o</sub> nom. Additionally note <sup>1)</sup> is applicable.  
Example: 12 IWR 1-15-1212-N: I<sub>o1</sub> = 37 mA, I<sub>o2</sub> = ±24 mA  
24 IWR 1-2x1212-N: I<sub>o1</sub> = +29 mA/-19 mA, I<sub>o2</sub> = +19 mA/-29 mA  
or: I<sub>o1</sub> = ±19 mA, I<sub>o2</sub> = ±29 mA
- Important:** The 5 V outputs need an external tantalum electrolytic capacitor with a value of at least 22 µF, 10 V.
- Temperature range N or T available only.
- See Block Diagrams page 5.

## Electrical Data

 $T_A = +25\text{ }^\circ\text{C}$ 

Characteristic	Conditions	5I..	12I..	15I..	24I..	28I..	48I..
No load input current $I_{i0}$ typ max	$U_{i\text{ nom}}, I_o = 0$	85mA 110mA	35mA 45mA	28mA 37mA	15mA 23mA	17mA 20mA	8mA 12mA
RFI voltage at the input $u_{i\text{ rfi}}$ typ	$U_{i\text{ nom}}, I_o\text{ nom}$ $L_{\text{source}} \approx 1\text{ }\mu\text{H}$	50 mV <sub>pp</sub>	80 mV <sub>pp</sub>	90 mV <sub>pp</sub>	100 mV <sub>pp</sub>	130 mV <sub>pp</sub>	200 mV <sub>pp</sub>
RFI current at the input $i_{i\text{ rfi}}$ typ		10 mA <sub>pp</sub>					
Switching freq. $f_s$ typ	$U_{i\text{ nom}}, I_o\text{ nom}$	25 kHz					
Impulse voltage withstand test	IEC 255.4	IWR Class III: 5 kV (1.2/50; 500 $\Omega$ )					
	Appendix E	ICR Class II: 1 kV (1.2/50; 500 $\Omega$ )					
Isolation test voltage $U_{is}$ input to outputs and output 1 to output 2	input short-circuited as well as outputs short-circuited	all IWR			3 kV <sub>pp</sub>		
		all ICR			500 V <sub>pp</sub>		
Coupling Cap. $C_{i0}$ typ		all IWR 10 pF,		all ICR 20 pF			
Isolation resistance $R_{is}$ typ	100 V DC after 1 min	2000 M $\Omega$					
Output voltage $U_o$ min nom max	$U_{i\text{ nom}}, I_o\text{ nom}$	$U_o\text{ nom} -5\%$					
		$U_o\text{ nom} +5\%$					
Temp. coefficient $\alpha_{U_o}$	$U_{i\text{ nom}}, I_o\text{ nom}$	$\pm 0.02\%$ /K					
Static control deviation versus input voltage $\Delta U_o U$ typ	$U_{i\text{ min}} \dots U_{i\text{ max}}$ $I_o\text{ nom}$	$\pm 0.2\%$ <sup>1)</sup>					
Static control deviation versus output current $\Delta U_o I$ typ	$U_{i\text{ nom}}$ $I_o = 0 \dots I_o\text{ nom}$	$\pm 0.1\%$ <sup>2)</sup>					
Output ripple (BW = 20 MHz) $u_o$ typ	$U_{i\text{ nom}}$ $I_o\text{ nom}$	25 mV <sub>pp</sub>	35 mV <sub>pp</sub>	40 mV <sub>pp</sub>	45 mV <sub>pp</sub>	50 mV <sub>pp</sub>	55 mV <sub>pp</sub>
Efficiency $\eta$ min typ		50 % 58 %					

<sup>1)</sup> for 5 V outputs: typ  $\pm 0.3\%$ <sup>2)</sup> for 5 V outputs: typ  $\pm 0.8\%$ 

Pin Configuration see page 5 and table below

Group	1	2	3	8	10	11	12	13	14	15	16	17	22	23	24
01	V1	V1	V1	-	-	-	Go	Vo	-	-	-	+TP	G1	G1	G1
02	V1	V1	V1	-	Go	Go	-TP	-Vo	-	+Vo	+TP	-	G1	G1	G1
03	V1	V1	V1	Go1	-	-	Vo1	Vo2	-	-	Go2	-	G1	G1	G1
04	V1	V1	-	-	Go1	-	Vo1	+Vo2	-	Go2	-	-Vo2	-	G1	G1
05	V1	V1	-	-Vo1	Go1	-	+Vo1	+Vo2	-	Go2	-	-Vo2	-	G1	G1
06	V1	-	-	-	Go	Vo	G1	G1	Vo	Go	-	-	-	-	V1
07	V1	-Vo	Go	-	Go	+Vo	G1	G1	+Vo	Go	-	-	Go	-Vo	V1
08	V1	Go2	Vo2	-	Go1	Vo1	G1	G1	Vo1	Go1	-	-	Vo2	Go2	V1

## Mechanical Data

same as Family LCR, LWR, page 8

Block Diagrams

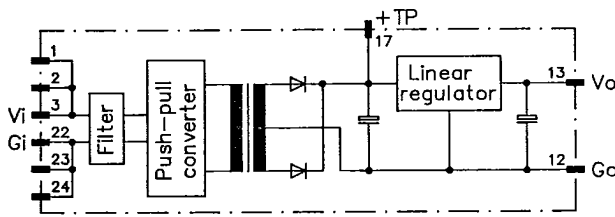

Fig. 1  
 IWR Group 01

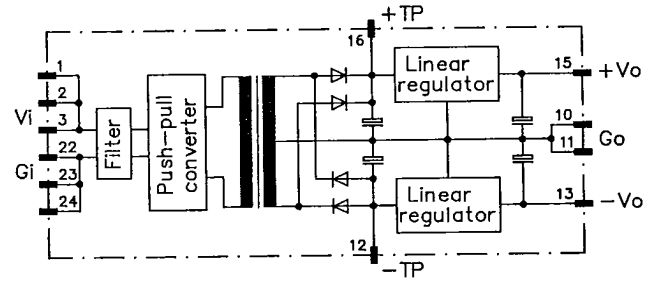

Fig. 2  
 IWR Group 02

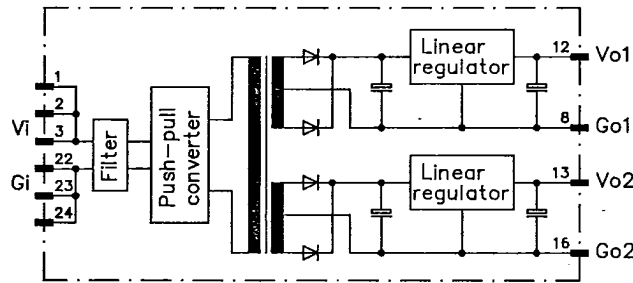

Fig. 3  
 IWR Group 03

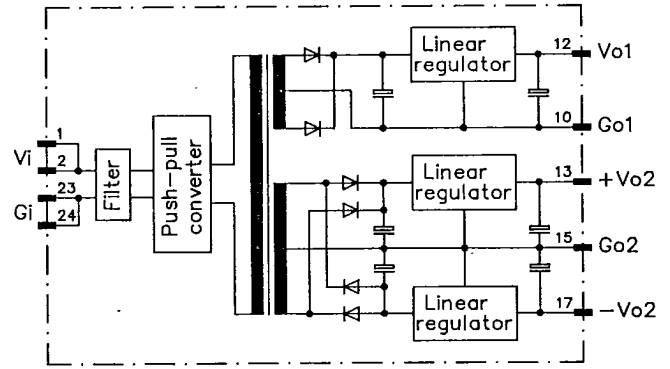

Fig. 4  
 IWR Group 04

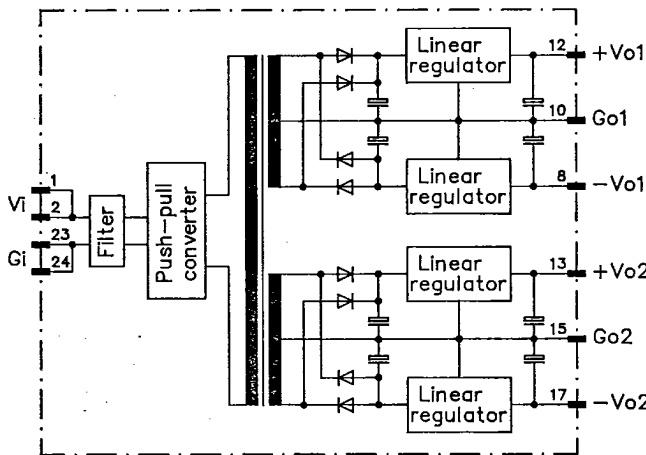

Fig. 5  
 IWR Group 05

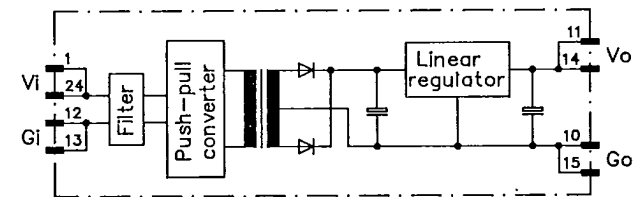

Fig. 6  
 ICR Group 06

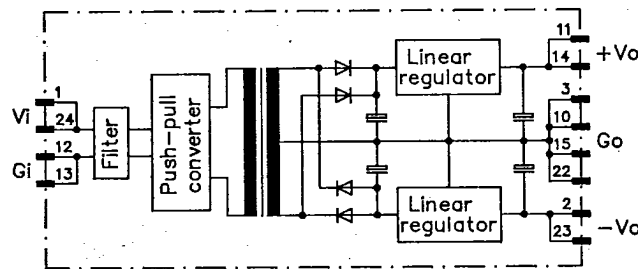

Fig. 7  
 ICR Group 07

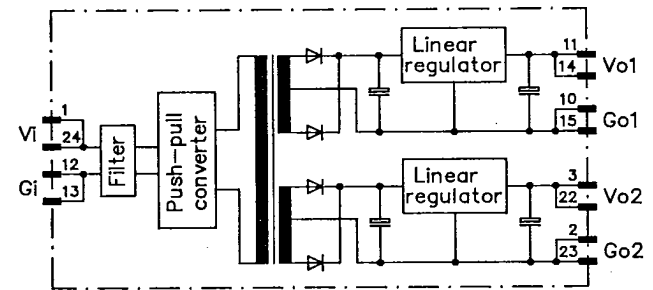

Fig. 8  
 ICR Group 08

MELCHER INC 03 DE 5975062 0000163 5