

Dimensions: mm and (In.)

Standard Resistance Taper

15A Taper (JIS A)

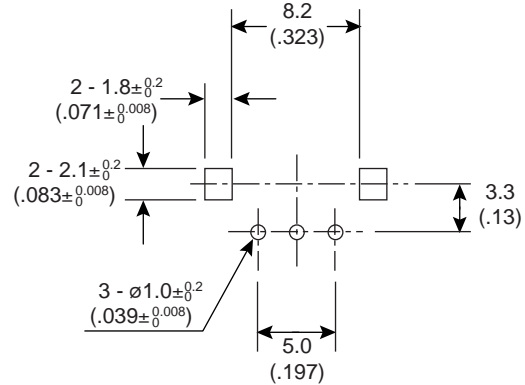
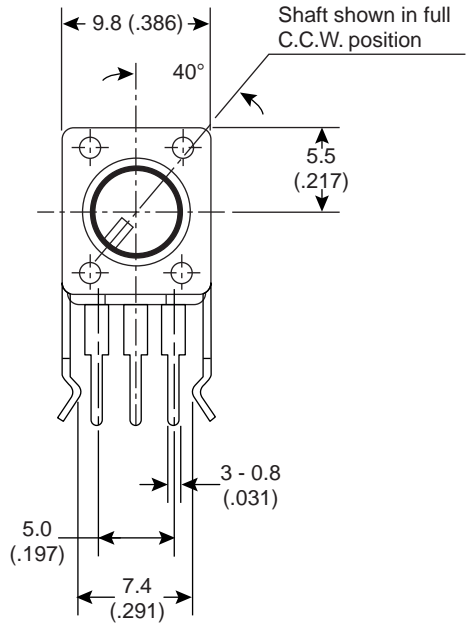
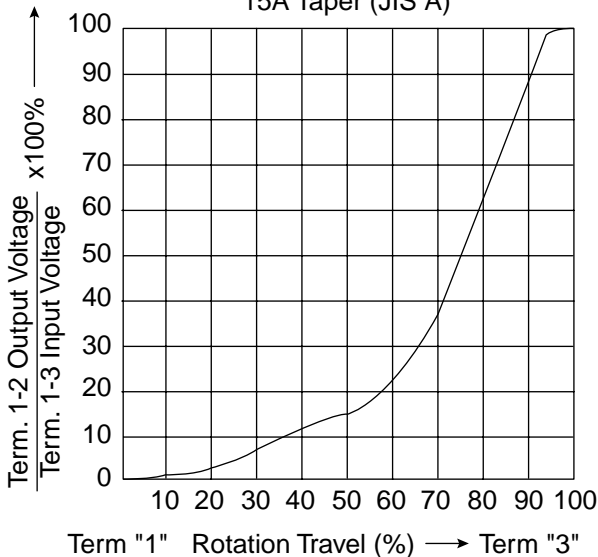

P.C.B. Mounting Hole Detail

Specifications:

- Mechanical Characteristics:
 - Total rotational angle: $280^\circ \pm 5^\circ$
 - Rotational torque: 10~100gf
 - Shaft stop strength: 3 kgf
 - Starting torque: 10~100gf-cm
- Electrical Characteristics:
 - Tolerance: $\pm 30\%$
 - Rated wattage: 0.05W
 - Maximum working voltage: AC 50V, DC20V
 - Noise (refer to JIS C6443): > 100 mV
 - Insulation resistance: 100M Ω min. @ DC250 volts
 - Taper: Audio
 - V.R. life: 10,000 Cycles
 - Click life: 5,000 Cycles
 - Note: Meet or exceed JISC 6443 Requirements