

EVALUATION KIT
AVAILABLE



Highest Efficiency Supply for 2 to 6 Series WLEDs in a 2mm x 2mm TDFN Package

General Description

The MAX8901A/MAX8901B step-up converters drive from two to six series-connected white LEDs (WLEDs) with constant current to provide uniform WLED intensity for LCD backlighting in cell phones, PDAs, and other hand-held devices. The MAX8901_ operate at a fixed 750kHz (typ) switching frequency, allowing for tiny external components, and are optimized for the highest possible efficiency over the full 1-cell Li+/Li-Poly battery range.

These converters use a single input (ON) to enable the IC and to control WLED intensity. The MAX8901A requires a direct PWM input to regulate WLED intensity with the WLED current proportional to the PWM duty cycle. The MAX8901B uses single-wire, serial-pulse dimming that reduces the WLED intensity in 32 linear steps. Full-scale WLED current for serial-pulse dimming is 24.75mA (MAX8901B, 0.75mA/step).

The MAX8901_ features an internal soft-start to eliminate inrush currents during startup, input overvoltage protection, WLED overvoltage protection, and a shutdown mode with 0.01µA (typ) shutdown current. No WLED current is present in shutdown provided the WLED forward voltage is greater than the input supply voltage. Additional features include undervoltage lockout (UVLO) and thermal shutdown.

The MAX8901_ are available in tiny 8-pin, 2mm x 2mm TDFN-EP packages (0.8mm max height).

Applications

Display Backlight (from 2 to 6 WLEDs)
Cellular Phones
PDAs and Smartphones
MP3 and Portable Media Players
Portable Navigation Devices
Digital Cameras

Features

- ◆ High Efficiency, Up to 91%
- ◆ 2.6V to 5.5V Input Voltage Range
- ◆ Fixed-Frequency Operation
- ◆ Supplies from 2 to 6 WLEDs with 1% LED Current Accuracy
- ◆ Flexible Dimming Control
 - Direct PWM Dimming (MAX8901A)
 - 32-Step, 1-Wire Serial Dimming (MAX8901B)
- ◆ Input Undervoltage Lockout
- ◆ Input Overvoltage Lockout
- ◆ WLED Overvoltage Protection (25V typ)
- ◆ 0.01µA (typ) Shutdown Current
- ◆ No WLED Current in Shutdown
- ◆ Internal Soft-Start and Thermal Shutdown

Ordering Information

PART	PIN-PACKAGE	PKG CODE	TOP MARK
MAX8901AETA+T	8 TDFN-EP* 2mm x 2mm	T822-1	+ABA
MAX8901BETA+T	8 TDFN-EP* 2mm x 2mm	T822-1	+ABB

Note: All devices are specified over the -40°C to +85°C operating temperature range.

+Denotes a lead-free package.

*EP = Exposed paddle.

T = Tape and reel.

Pin Configuration appears at end of data sheet.

Typical Operating Circuits

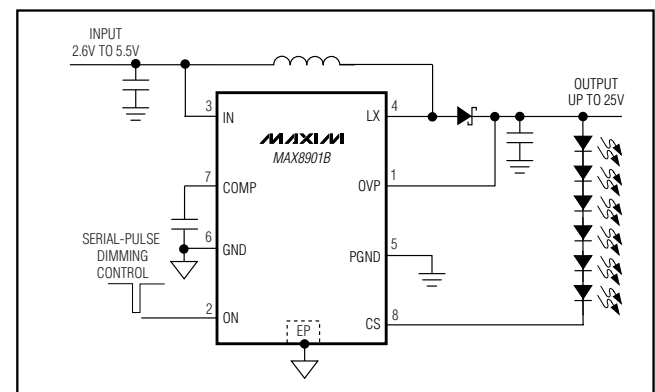
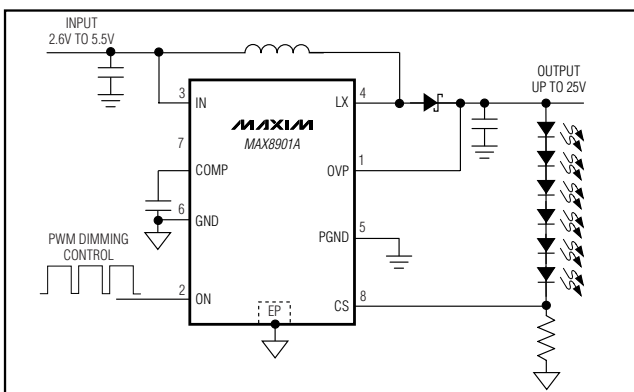

Highest Efficiency Supply for 2 to 6 Series WLEDs in a 2mm x 2mm TDFN Package

ABSOLUTE MAXIMUM RATINGS

IN to GND	-0.3V to +7V	Operating Temperature Range	-40°C to +85°C
CS, COMP, ON to GND	-0.3V to (V _{IN} + 0.3V)	Junction Temperature	+150°C
OVP, LX to GND	-0.3V to +28V	Storage Temperature Range	-65°C to +150°C
PGND to GND	-0.3V to +0.3V	Lead Temperature (soldering, 10s)	+300°C
LX Current	770mA _{RMS}		
Continuous Power Dissipation (multilayer board at +70°C)			
8-pin, 2mm x 2mm TDFN			
(derate above +70°C by 11.9mW/°C)	953mW		

Stresses beyond those listed under "Absolute Maximum Ratings" may cause permanent damage to the device. These are stress ratings only, and functional operation of the device at these or any other conditions beyond those indicated in the operational sections of the specifications is not implied. Exposure to absolute maximum rating conditions for extended periods may affect device reliability.

ELECTRICAL CHARACTERISTICS

(V_{IN} = V_{ON} = V_{OVP} = 3.6V, V_{PGND} = V_{GND} = 0V, COMP, CS, and LX are unconnected, T_A = -40°C to +85°C, unless otherwise noted. Typical values are at T_A = +25°C.) (Note 1)

PARAMETER	SYMBOL	CONDITIONS		MIN	TYP	MAX	UNITS
Input Voltage	V _{IN}			2.6		5.5	V
Input Undervoltage Lockout Threshold	V _{IN_UVLO}	V _{IN} rising		2.25		2.50	V
		V _{IN} falling		2.20		2.53	
Input Overvoltage Lockout Threshold	V _{IN_OVLO}	V _{IN} rising		6.2		6.3	V
		V _{IN} falling		6.0		6.3	
Shutdown Input Current	I _{SHDN}	V _{ON} = 0V	T _A = +25°C	0.01		1	μA
			T _A = +85°C		0.1		
Quiescent Current	I _Q	V _{CS} = 0.55V, no load (not switching)	MAX8901A		70	135	μA
			MAX8901B		115	185	
Output Voltage Range	V _{OUT}	V _{DIODE} = external boost diode voltage drop		V _{IN} - V _{DIODE}		V _{OV}	V
OVP Overvoltage Protection Threshold	V _{OV}	6 LEDs with 25V OVP option		24	25	26	V
OVP Input Current	I _{OV}	V _{OVP} = 20V			20		μA
CS Regulation Voltage	V _{CS}	No dimming		0.475	0.50	0.525	V
ON Shutdown Delay	t _{SHDN}	Time V _{ON} is below low threshold until shutdown (Figure 1)		1.18	1.33	1.50	ms
ON High Voltage	V _{ON_HI}	2.6V < V _{IN} < 5.5V		1.3			V
ON Low Voltage	V _{ON_LO}	2.6V < V _{IN} < 5.5V				0.4	V
ON Input Current	I _{ON}	ON = IN	T _A = +25°C	0.01		1	μA
			T _A = +85°C		0.1		
Initial ON High Pulse Width	t _{HI_INIT}	First ON high pulse to enable IC (MAX8901B) (Figure 1)		40			μs
ON High Pulse Width	t _{HI}	MAX8901B (Figure 1)		0.5			μs
ON Low Pulse Width	t _{LO}	MAX8901B (Figure 1)		0.5		500.0	μs

Highest Efficiency Supply for 2 to 6 Series WLEDs in a 2mm x 2mm TDFN Package

ELECTRICAL CHARACTERISTICS (continued)

($V_{IN} = V_{ON} = V_{OVP} = 3.6V$, $V_{PGND} = V_{GND} = 0V$, COMP, CS, and LX are unconnected, $T_A = -40^{\circ}C$ to $+85^{\circ}C$, unless otherwise noted. Typical values are at $T_A = +25^{\circ}C$.) (Note 1)

PARAMETER	SYMBOL	CONDITIONS	MIN	TYP	MAX	UNITS
Serial Dimming Full-Scale LED Current Accuracy		$I_{LED} = 24.75mA$ (MAX8901B)	$T_A = +25^{\circ}C$	-1	+1	%
			$T_A = -40^{\circ}C$ to $+85^{\circ}C$	-3	+3	%
PWM Frequency for PWM Dimming Control	f _{PWM}	MAX8901A		100		kHz
CS to COMP Transconductance			40	60	80	μS
Soft-Start Interval	t _{SOFT-START}	C _{COMP} = 0.022μF (Figure 1)		10		ms
Thermal Shutdown				160		°C
OSCILLATOR						
Operating Frequency	f _{sw}		700	750	800	kHz
Maximum Duty Cycle	D _{MAX}	V _{CS} = 0.4V	90	92		%
n-CHANNEL SWITCH						
LX Leakage Current	I _{LXLKG}	V _{LX} = 27V	$T_A = +25^{\circ}C$	0.1	5	μA
			$T_A = +85^{\circ}C$	0.1		
n-Channel Switch On-Resistance	R _{LX}			0.7	1.4	Ω
n-Channel Current Limit	I _{LIM}		0.63	0.70	0.77	A

Note 1: Specifications to $-40^{\circ}C$ are guaranteed by design and characterization and are not production tested.

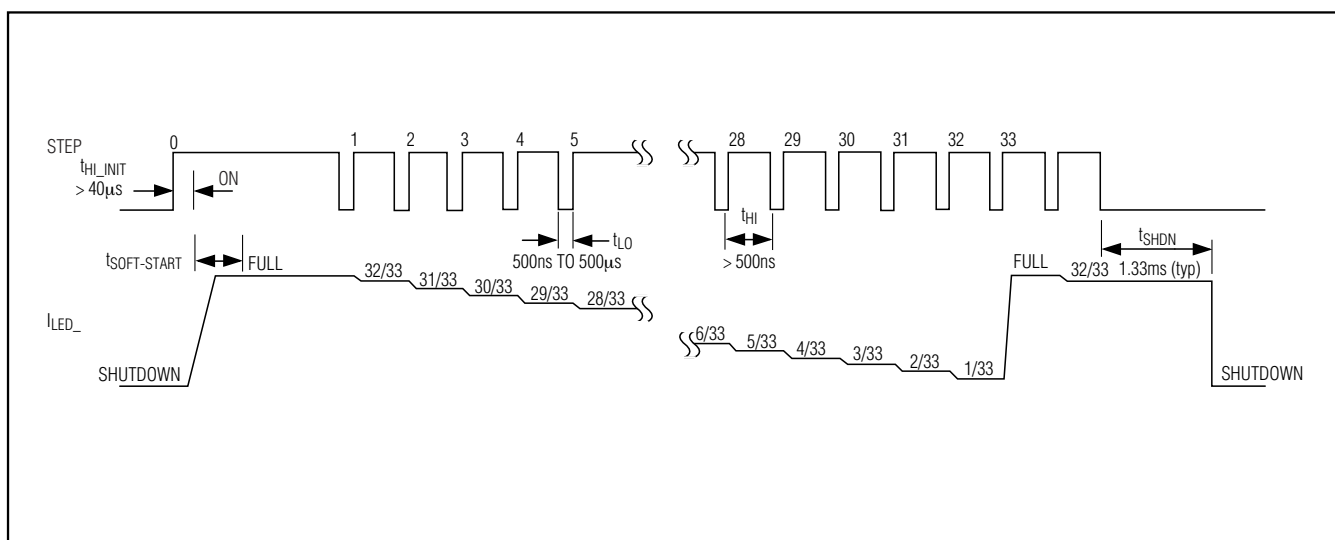
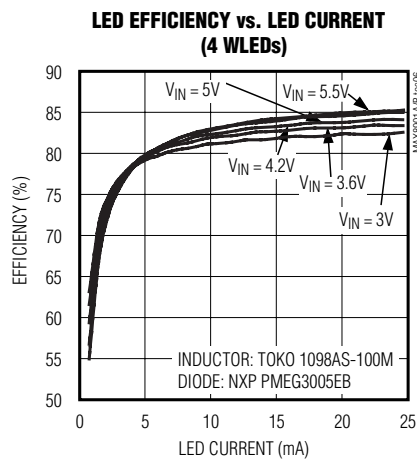
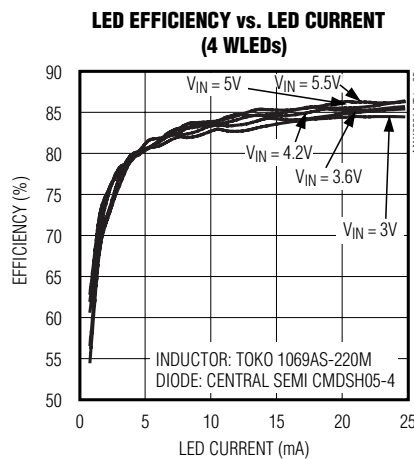
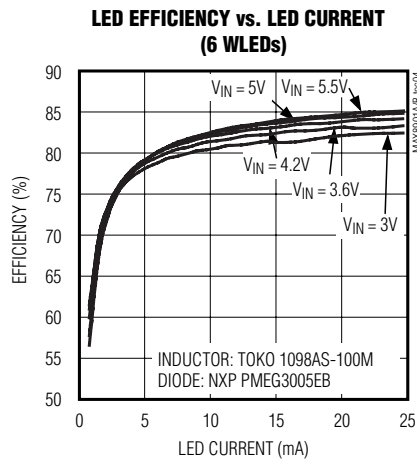
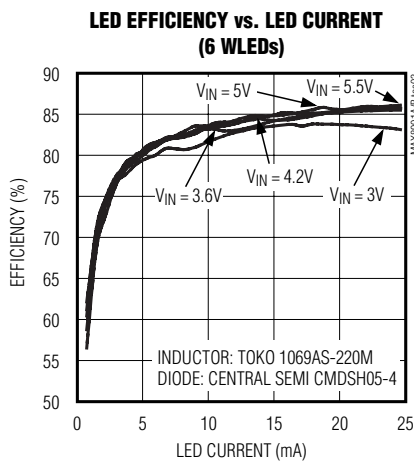
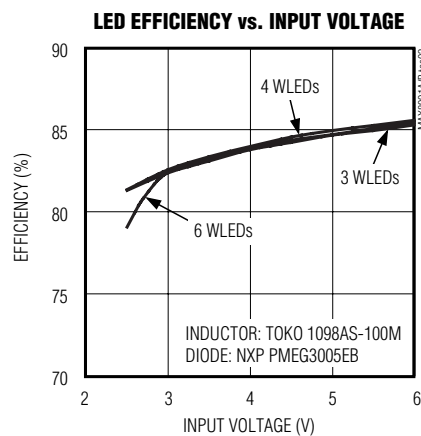
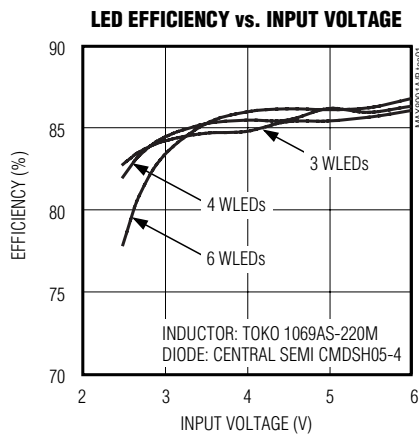

Figure 1. MAX8901B Timing Diagram

Highest Efficiency Supply for 2 to 6 Series WLEDs in a 2mm x 2mm TDFN Package

Typical Operating Characteristics

(Circuit of Figure 5, $I_{LED} = 24.75mA$, $V_{IN} = V_{ON} = 3.6V$, $C1 = 1\mu F$, $C2 = 1\mu F$, $T_A = +25^\circ C$, unless otherwise noted.)



Highest Efficiency Supply for 2 to 6 Series WLEDs in a 2mm x 2mm TDFN Package

Typical Operating Characteristics (continued)

(Circuit of Figure 5, $I_{LED} = 24.75\text{mA}$, $V_{IN} = V_{ON} = 3.6\text{V}$, $C1 = 1\mu\text{F}$, $C2 = 1\mu\text{F}$, $T_A = +25^\circ\text{C}$, unless otherwise noted.)

MAX8901A/MAX8901B

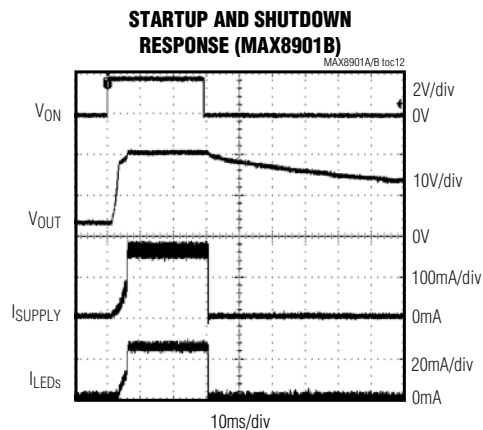
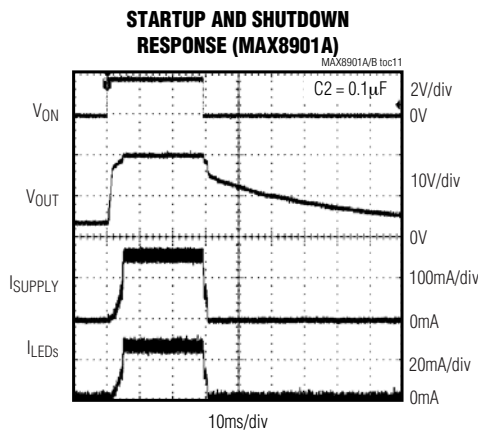
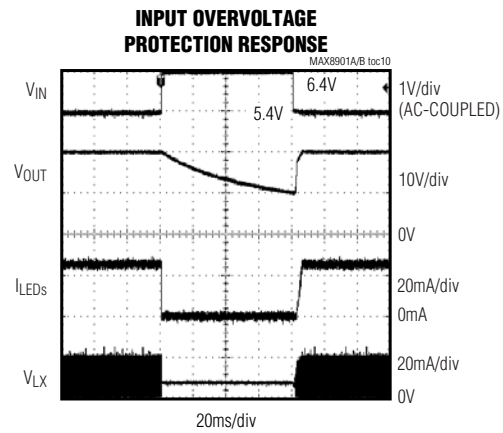
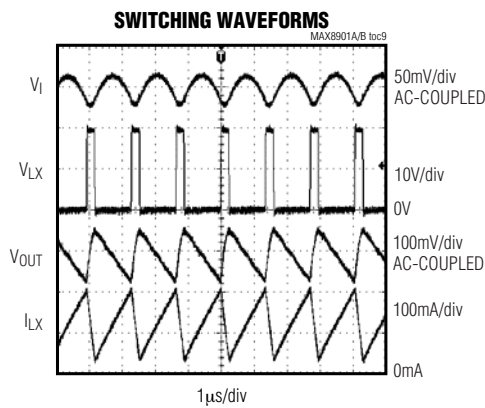
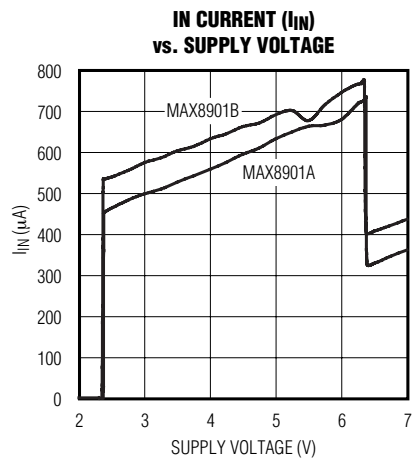
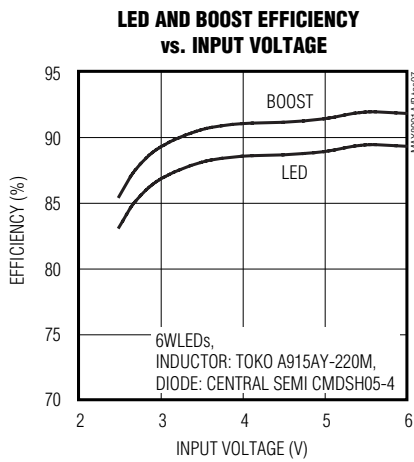

Highest Efficiency Supply for 2 to 6 Series WLEDs in a 2mm x 2mm TDFN Package

Typical Operating Characteristics (continued)

(Circuit of Figure 5, $I_{LED} = 24.75\text{mA}$, $V_{IN} = V_{ON} = 3.6\text{V}$, $C1 = 1\mu\text{F}$, $C2 = 1\mu\text{F}$, $T_A = +25^\circ\text{C}$, unless otherwise noted.)

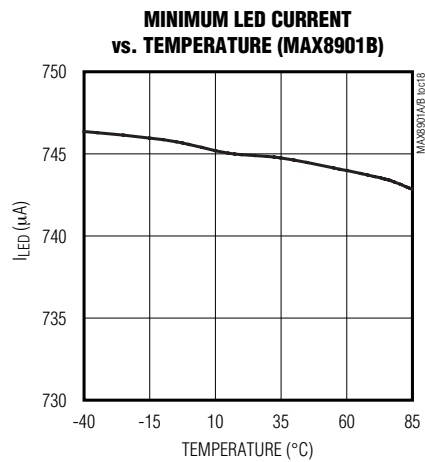
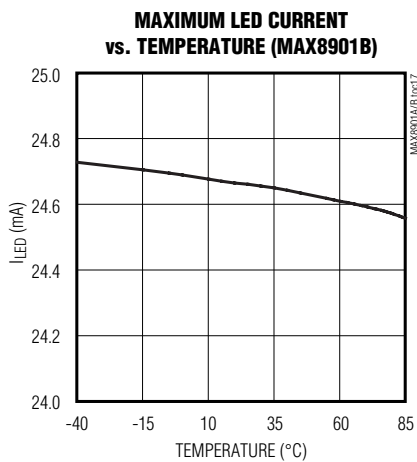
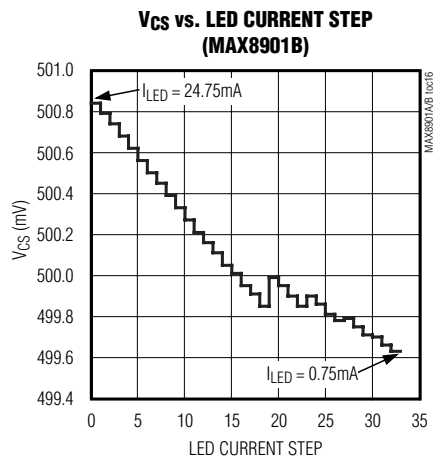
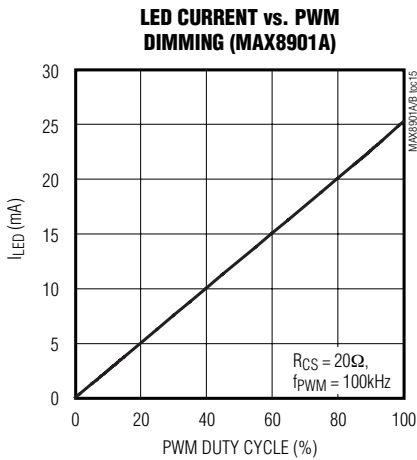
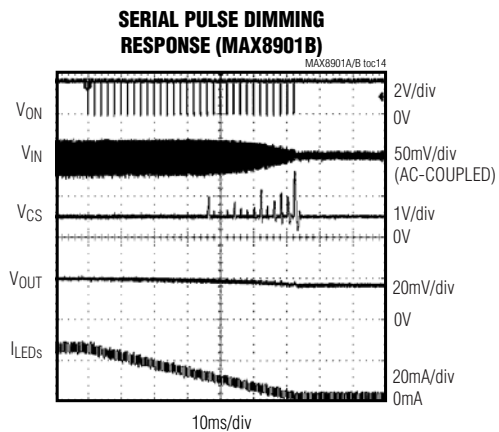
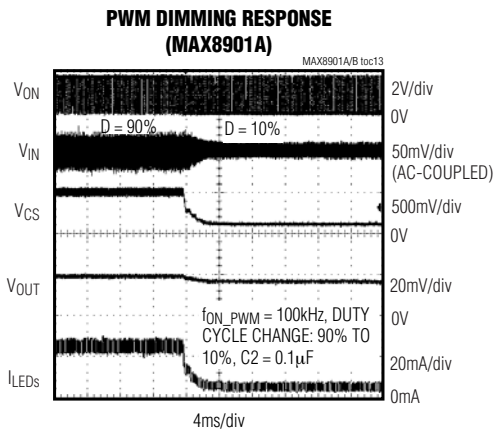

Highest Efficiency Supply for 2 to 6 Series WLEDs in a 2mm x 2mm TDFN Package

Pin Description

PIN	NAME	FUNCTION
1	OVP	WLED Overvoltage Protection Input. OVP monitors voltage at the WLEDs. Connect OVP to the positive terminal of the output capacitor. If an OVP condition is detected, the MAX8901_ latches off. Cycle V_{IN} or toggle V_{ON} to restart the IC.
2	ON	<p>Enable and Dimming Control Input. Drive ON high to enable the IC. Drive ON low for greater than 1.33ms (typ) to shutdown the WLED current regulator.</p> <p>For the MAX8901A: After V_{IN} is above V_{UVLO} and ON is driven high, the MAX8901A enters soft-start and increases the WLED current to full brightness. Apply a minimum 30kHz (500kHz max) PWM signal to ON to adjust the WLED brightness from 100% to off, proportional to the duty cycle of the PWM signal. See the <i>PWM Dimming Control (MAX8901A)</i> section for more details.</p> <p>For the MAX8901B: After ON is driven high for 40μs (min), the MAX8901B enters soft-start and increases the WLED current to full brightness. Subsequent pulses on ON cause the MAX8901B WLED current to decrease in 32 equal steps. See the <i>Serial-Pulse Dimming Control (MAX8901B)</i> section for more details.</p>
3	IN	Power Supply Input. Bypass IN to GND with a 1 μ F ceramic capacitor placed as close as possible to the IC. If V_{IN} exceeds the input overvoltage lockout threshold (6.5V max, V_{IN} rising), the IC stops switching and no WLED current flows (if the forward voltage of the WLED string is greater than V_{IN}). When V_{IN} falls below the overvoltage lockout hysteresis level (6.0V min, V_{IN} falling), soft-start is initiated and normal operation resumes.
4	LX	Boost Inductor Node. Connect an inductor between IN and LX. LX is high impedance in shutdown.
5	PGND	Power Ground. Connect to GND and the exposed paddle (EP) with a short, wide trace.
6	GND	Analog Ground. Connect GND to the exposed paddle with a short, wide trace.
7	COMP	WLED Boost Compensation Node. Connect a 0.022 μ F ceramic capacitor from COMP to GND. C_{COMP} stabilizes the converter and sets the soft-start time. COMP discharges to GND when in shutdown.
8	CS	WLED Current Sense Input. For the MAX8901A, connect a current-sense resistor from CS to GND. Voltage sensed at CS regulates the WLED current. For the MAX8901B, do not connect a sense resistor from CS to GND. The MAX8901B provides an internal current source from CS to GND to program the WLED current. The MAX8901B regulates V_{CS} to 0.5V (typ) for all I_{LED} . The MAX8901A regulates V_{CS} to 0.5V (typ) for maximum duty cycle only.
—	EP	Exposed Metal Paddle. Connect EP to GND. For good thermal dissipation, the exposed paddle must be connected to a large ground plane.

MAX8901A/MAX8901B

Highest Efficiency Supply for 2 to 6 Series WLEDs in a 2mm x 2mm TDFN Package

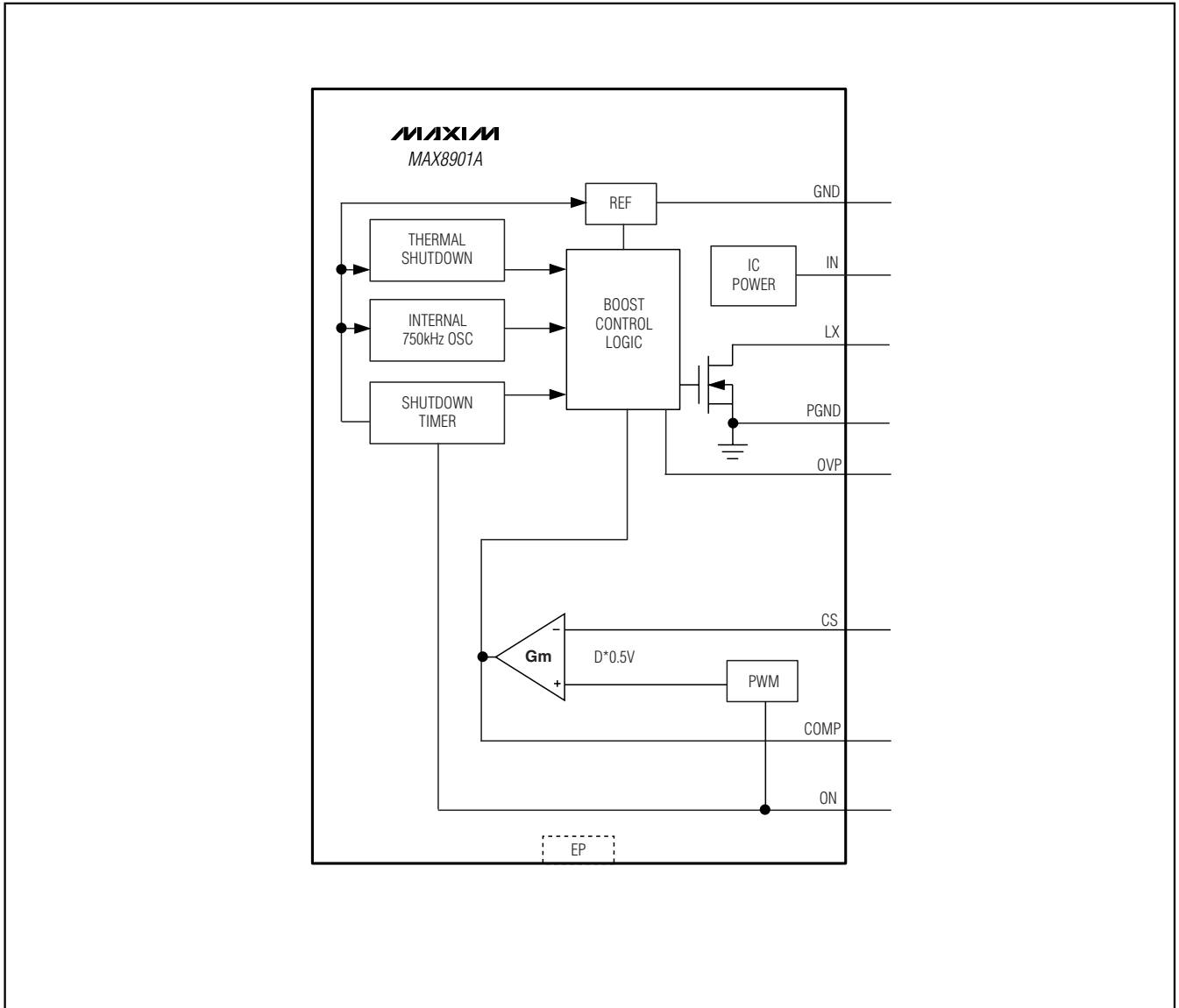

Figure 2. MAX8901A Block Diagram

Detailed Description

The high efficiency and tiny size of the MAX8901A/MAX8901B WLED step-up converters make them ideally suited for driving LCD backlighting in cell phones, PDAs, and other portable and handheld devices. The MAX8901_ drive from 2 to 6 series-connected WLEDs with constant current for uniform WLED intensity and are optimized for the highest possible efficiency (up to 91%) over the full 1-cell Li+/Li-Poly battery range. These tiny 2mm x 2mm devices operate at a constant 750kHz

switching frequency, and use small external components to achieve minimal input and output ripple while occupying the smallest possible footprint.

These converters use a single input (ON) to enable the IC and to control WLED intensity. The MAX8901A requires a direct PWM input to modulate WLED intensity, with WLED current proportional to the PWM duty cycle. The MAX8901B uses single-wire, serial-pulse dimming that reduces the WLED intensity in 32 equal steps. Full-scale WLED current for serial-pulse dimming is 24.75mA.

Highest Efficiency Supply for 2 to 6 Series WLEDs in a 2mm x 2mm TDFN Package

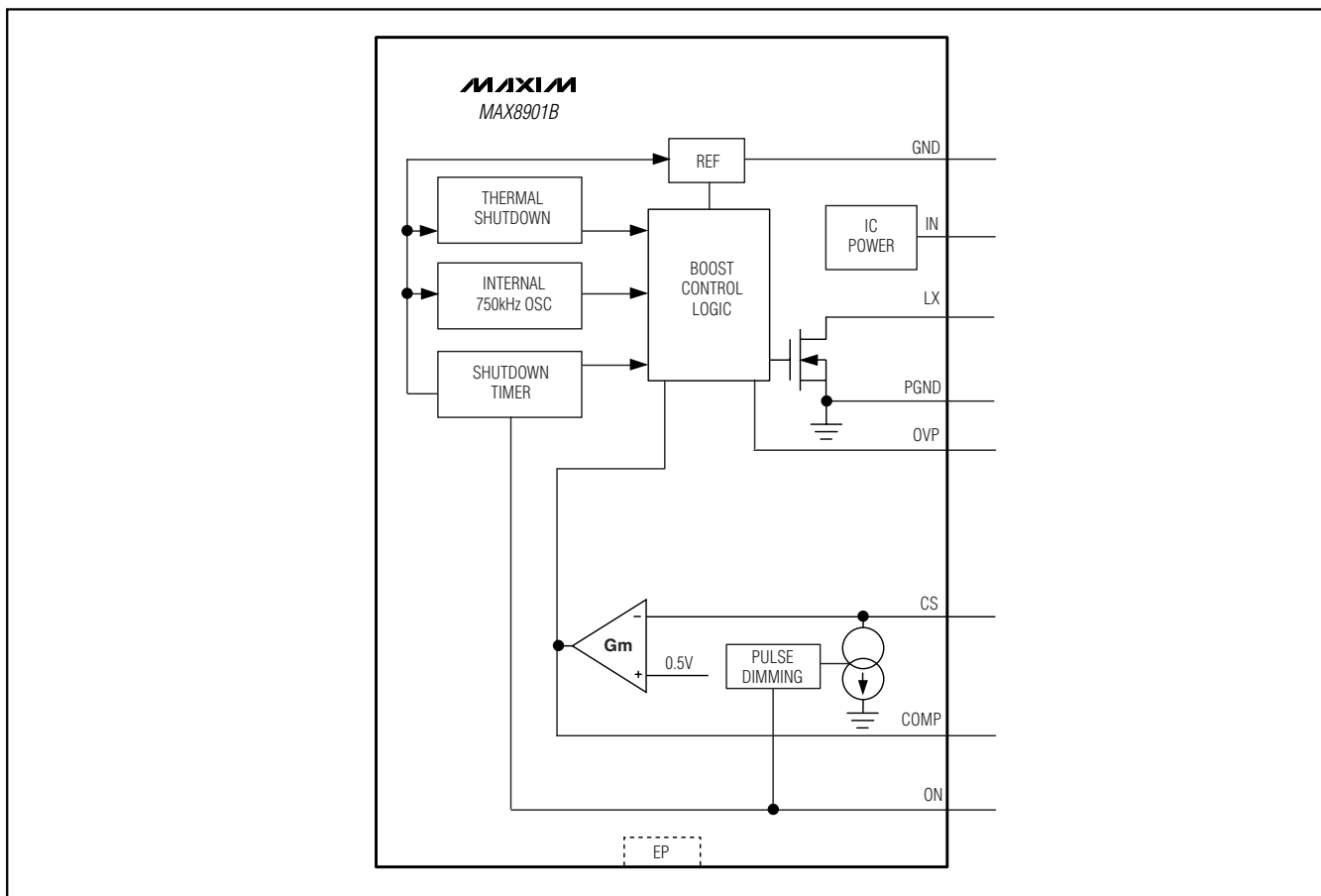

Figure 3. MAX8901B Block Diagram

The MAX8901_ features:

- Internal soft-start that gradually illuminates the WLEDs to eliminate inrush current during startup.
- Input overvoltage protection (6.5V max) that prevents IC switching when exceeded.
- WLED overvoltage protection (25V typ) that latches off the IC.
- Shutdown mode that reduces current to 0.01µA (typ).

No WLED current is present in shutdown or during an overvoltage condition if the WLED forward voltage is greater than the input supply voltage. Figures 2 and 3 show the block diagrams for the MAX8901A and MAX8901B, respectively.

Input Overvoltage Lockout

When V_{IN} exceeds 6.2V (min), input overvoltage lockout (OVLO) is engaged to protect the MAX8901_ from high-input voltage conditions. Once input OVLO occurs, the MAX8901_ stops switching and no WLED current flows, provided the forward voltage of the WLED string is greater than V_{IN} . When V_{IN} falls below 6V (min), the input OVLO condition is cleared, and the IC is enabled and enters soft-start.

WLED Overvoltage Protection

WLED overvoltage protection (OVP) occurs when the WLED output voltage rises above the WLED OVP threshold. The WLED OVP protection circuitry latches off the IC and the IC enters shutdown when the WLED OVP threshold is exceeded. After OVP is engaged, cycle V_{IN} or toggle ON to reenable the IC and enter soft-start.

Highest Efficiency Supply for 2 to 6 Series WLEDs in a 2mm x 2mm TDFN Package

Startup and Soft-Start

The MAX8901_ use a single input (ON) to enable the IC and to control WLED intensity. After ON is driven high, the MAX8901_ enter soft-start and gradually increase the WLED current to full brightness.

When the MAX8901_ is first turned on, C_{COMP} is charged to 1.25V with a 60μA current source. When V_{COMP} rises above 1.25V, C_{COMP} is charged with a 4μA current source, and the internal MOSFET begins switching at a reduced duty cycle. When V_{COMP} rises above 2.25V, the duty cycle is at its maximum. The V_{COMP} where the IC exits soft-start depends on the final duty cycle required by the load. Typical shutdown timing characteristics are shown in the *Typical Operating Characteristics* section.

A PWM signal (MAX8901A) or serial pulses (MAX8901B) are applied to dim the WLEDs. See the *PWM Dimming Control (MAX8901A)* and *Serial-Pulse Dimming Control (MAX8901B)* sections for more details.

Shutdown

The MAX8901_ enter shutdown when V_{ON} is held low for more than 1.33ms (typ), or when an output overvoltage condition is engaged. In shutdown, the supply current is reduced to 0.01μA (typ) by powering down the entire IC except for the ON voltage-detection circuitry. C_{COMP} is discharged to GND during shutdown, allowing the device to reinitiate soft-start when it is re-enabled. Although the internal n-channel MOSFET does not switch in shutdown, there is still a DC current path between the input and the WLEDs through the inductor and Schottky diode. In shutdown, the minimum forward voltage of the WLED string must exceed the maximum input voltage to ensure that the WLEDs remain off. Typically, with two or more WLEDs, the forward voltage is large enough to keep leakage current low, less than 1μA (typ). Shutdown timing characteristics are shown in the *Typical Operating Characteristics*.

Thermal Shutdown

The MAX8901 includes a thermal shutdown feature that protects the IC by turning it off when the die temperature reaches +160°C (typ). After thermal shutdown occurs, the MAX8901_ must be restarted by toggling the ON pin low, then high, or by cycling the input voltage.

PWM Dimming Control (MAX8901A)

After V_{IN} is above UVLO, apply a PWM signal to ON for a WLED current that is proportional to the PWM signal's duty cycle (0% duty cycle corresponds to zero LED current and 100% duty cycle corresponds to full LED current). Restrict PWM frequency to between 30kHz to 500kHz for a maximum I_{LED} current accuracy. If dimming control is not required, ON works as a simple on/off control. Drive ON high to enable the IC, or drive ON low for shutdown. A resistor connected from CS to GND programs maximum I_{LED}. See the *Current-Sense Resistor (MAX8901A Only)* section for more details.

Serial-Pulse Dimming Control (MAX8901B)

After the MAX8901B is enabled by driving ON high for the minimum initial ON high pulse width (40μs, min), soft-start is engaged and brings WLED current to maximum brightness. After soft-start is completed, dim the MAX8901B by pulsing ON low (500ns to 500μs pulse width). Each pulse reduces the WLED current by 0.75mA. The maximum WLED current is 24.75mA for the MAX8901B (0.75mA/step). The overall dimming range for serial-pulse dimming control is from maximum WLED current down to 1/33 of maximum WLED current. The WLEDs are turned off by holding ON low for at least 1.33ms (typ). See Figure 1 for the serial-pulse dimming control timing diagram.

Applications Information

Inductor Selection

Recommended inductor values range from 10μH to 47μH. A 22μH inductor optimizes the efficiency for most applications while maintaining low input voltage ripple. With input voltages near 5V, a larger value of inductance may be more efficient. To prevent core saturation, ensure that the inductor saturation current rating exceeds the peak inductor current for the application. Calculate the peak inductor current with the following formula:

$$I_{PEAK} = \frac{V_{OUT(MAX)} \times I_{LED(MAX)}}{900 \times V_{IN(MIN)}} + \frac{V_{IN(MIN)} \times 1.2}{2 \times L}$$

where I_{LED(MAX)} is in mA and L is in μH.

Highest Efficiency Supply for 2 to 6 Series WLEDs in a 2mm x 2mm TDFN Package

Schottky Diode Selection

The high switching frequency of the MAX8901_ demands a high-speed rectification diode for optimum efficiency. A Schottky diode is recommended due to its fast recovery time and low forward voltage drop. Ensure that the diode's average and peak current rating exceeds the average output current and peak inductor current. In addition, the diode's reverse breakdown voltage must exceed V_{OUT} . The RMS diode current can be approximated from the following equation:

$$I_{DIODE(RMS)} = \sqrt{I_{LED} \times I_{PEAK}}$$

Capacitor Selection

Ceramic capacitors with X5R, X7R, or better dielectric are recommended for stable operation over the entire operating temperature range. The exact values of input (C1) and output (C2) capacitors are not critical (see Figures 4 and 5). The typical value for the input capacitor is 1 μ F, and the typical value for the output capacitor is 0.1 μ F (MAX8901A) or 1 μ F (MAX8901B). Higher value capacitors can reduce input and output ripple, but at the expense of size and higher cost. The compensation capacitor (C3) stabilizes the converter and controls soft-start. The compensation capacitor is typically chosen to be 0.022 μ F for most applications.

Current-Sense Resistor (MAX8901A Only)

The MAX8901A uses a sense resistor (R_{CS}) connected from CS to GND to program the maximum WLED current for 100% PWM duty cycle. The MAX8901A regulates V_{CS} to 0.5V (typ) for 100% duty cycle. Calculate R_{CS} (in ohms) using the following equation:

$$R_{CS} = \frac{500}{I_{LED(MAX)}}$$

where $I_{LED(MAX)}$ is the maximum WLED current in milliamps. Maximum WLED current is programmed to 25mA using a 20 Ω resistor.

PCB Layout

Due to fast switching waveforms and high-current paths, careful attention is required when the PCB layout is designed. Minimize trace lengths between the IC and the inductor, the diode, the input capacitor, and the output capacitor. For the MAX8901A, minimize the trace length between the IC and R_{CS} . Keep traces short, direct, and wide. Keep noisy traces, such as the LX node trace, away from CS. The input bypass capacitor (C_{IN}) should be placed as close as possible to the IC. The ground connections of C_{IN} and C_{OUT} should be as close together as possible. PGND and GND should be connected together at the input capacitor ground terminal. Refer to the MAX8901 EV Kit for an example layout.

Highest Efficiency Supply for 2 to 6 Series WLEDs in a 2mm x 2mm TDFN Package

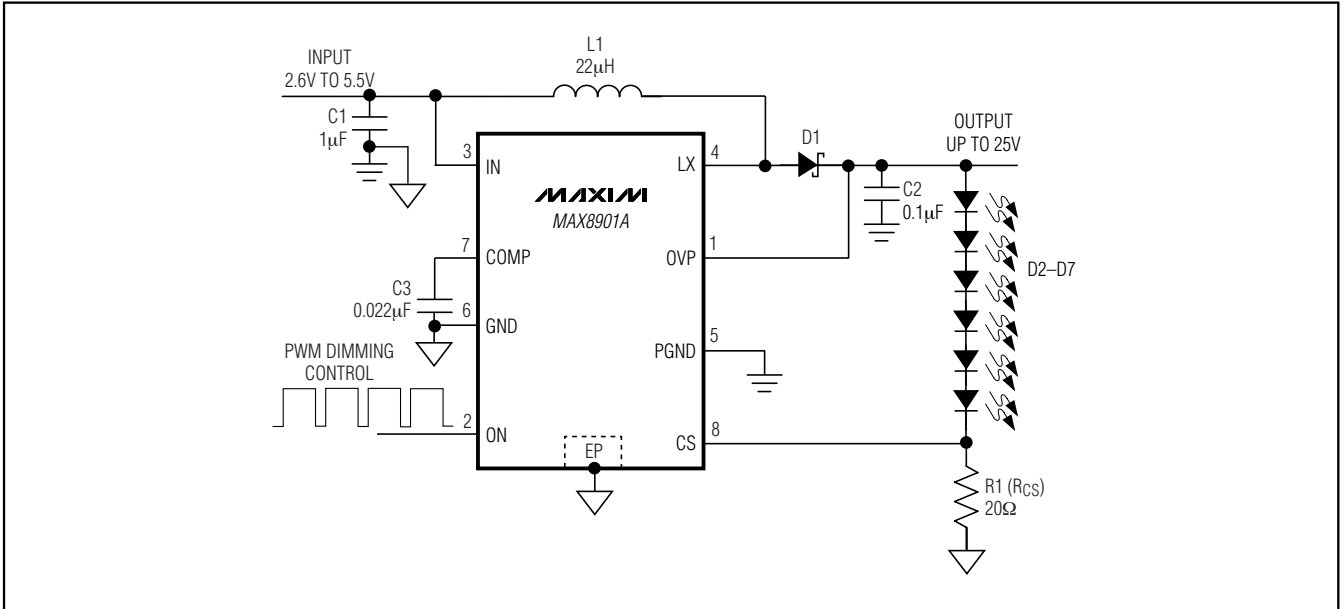

Figure 4. MAX8901A Application Circuit

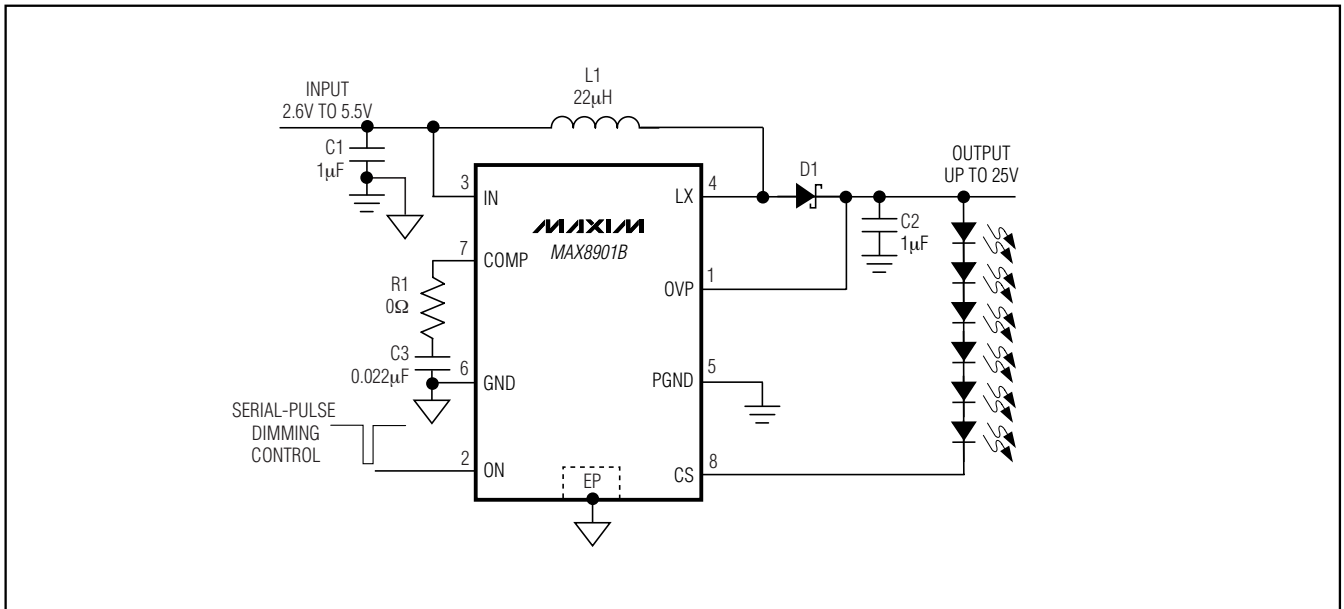
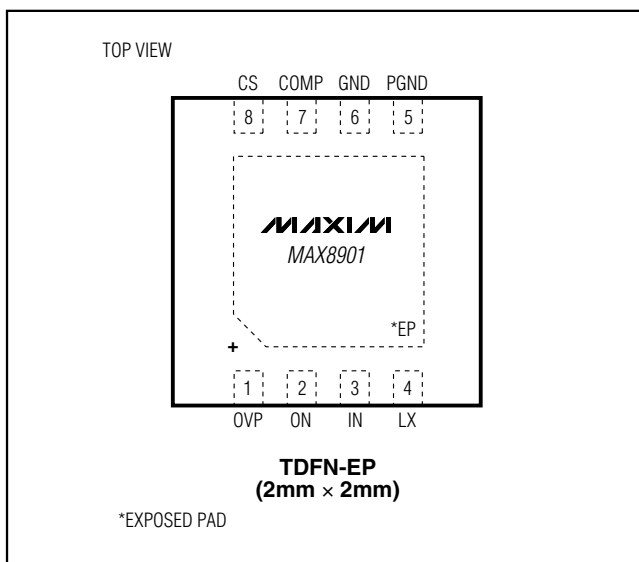

Figure 5. MAX8901B Application Circuit

Highest Efficiency Supply for 2 to 6 Series WLEDs in a 2mm x 2mm TDFN Package

Pin Configuration



Chip Information

PROCESS: BICMOS

MAX8901A/MAX8901B

Highest Efficiency Supply for 2 to 6 Series WLEDs in a 2mm x 2mm TDFN Package

Package Information (continued)

(The package drawing(s) in this data sheet may not reflect the most current specifications. For the latest package outline information go to www.maxim-ic.com/packages.)

MAX8901A/MAX8901B

COMMON DIMENSIONS		
SYMBOL	MIN.	MAX.
A	0.70	0.80
D	1.90	2.10
E	1.90	2.10
A1	0.00	0.05
L	0.20	0.40
k	0.25 MIN.	
A2	0.20 REF.	

PACKAGE VARIATIONS							
PKG. CODE	N	D2	E2	e	b	r	[(N/2)-1] x e
T622-1	6	0.90±0.10	1.60±0.10	0.65 TYP.	0.30±0.05	0.150	1.30 REF
T822-1	8	0.70±0.10	1.30±0.10	0.50 TYP.	0.25±0.05	0.125	1.50 REF
T822-2	8	0.80±0.10	1.20±0.10	0.50 TYP.	0.25±0.05	0.125	1.50 REF

NOTES:

1. ALL DIMENSIONS ARE IN mm. ANGLES IN DEGREES.
2. COPLANARITY APPLIES TO THE EXPOSED PAD AS WELL AS THE TERMINALS. COPLANARITY SHALL NOT EXCEED 0.08 mm.
3. WARPAGE SHALL NOT EXCEED 0.08 mm.
4. PACKAGE LENGTH/PACKAGE WIDTH ARE CONSIDERED AS SPECIAL CHARACTERISTIC(S).
5. COMPLY TO JEDEC MO229 EXCEPT D2 AND E2 DIMENSIONS.
6. "N" IS THE TOTAL NUMBER OF LEADS.
7. NUMBER OF LEADS SHOWN ARE FOR REFERENCE ONLY.
8.  MARKING IS FOR PACKAGE ORIENTATION REFERENCE ONLY.

-DRAWING NOT TO SCALE-

		
TITLE PACKAGE OUTLINE 6 & 8L TDFN EXPOSED PAD, 2x2x0.80mm		
APPROVAL	DOCUMENT CONTROL NO. 21-0168	REV. D 2/2

Maxim cannot assume responsibility for use of any circuitry other than circuitry entirely embodied in a Maxim product. No circuit patent licenses are implied. Maxim reserves the right to change the circuitry and specifications without notice at any time.

Maxim Integrated Products, 120 San Gabriel Drive, Sunnyvale, CA 94086 408-737-7600 _____ 15