

DIGITAL TRANSISTOR

APPLICATION:

- Inverter, Driver & Interface Circuits

FEATURES:

- Replaces up to three parts (1 transistor & 2 resistors) with one part
- Available in a variety of surface mount or leaded (thru-hole) packages
- High packing density requires less board space
- Cost savings due to fewer components to purchase & stock & handle
- Improved reliability due to reduced number of components
- Available in PNP & NPN polarities
- Available in 100 mA & 500 mA devices
- Decreased parasitic effects
- Double diffused silicon, Epitaxial Planar Transistor with thin film internal bias resistors

EQUIVALENT CIRCUITS:

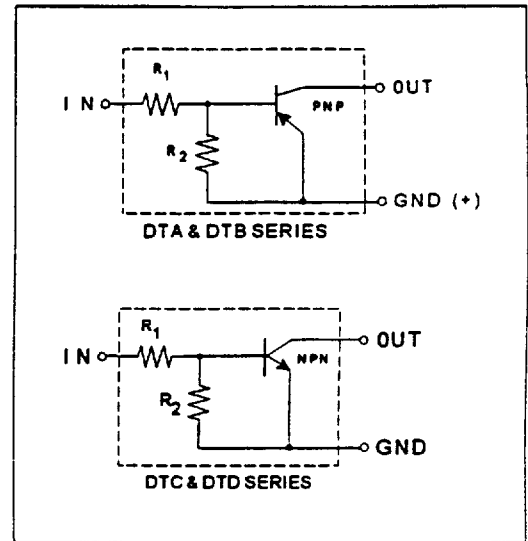

MAXIMUM RATINGS:

PARAMETER	PNP		NPN		UNITS
	DTA	DTB	DTC	DTD	
Power Supply Voltage (V_{CC})	50	50	50	50	Volts
Collector Current (I_C)	100	500	100	500	mA
Junction Temperature (T_j)	+125	+125	+125	+125	°C
Storage Temperature (T_{stg})	-55 to +125	-55 to +125	-55 to +125	-55 to +125	°C
Power Dissipation (P_d)	Rated by Package -- See Table Below				mW

MAXIMUM POWER DISSIPATION BY PACKAGE: P_d (mW)

Test Condition	SURFACE MOUNT DEVICES				THRU-HOLE (LEADED) DEVICES				
	SST (SOT-23)	SMT (SC-59)	UMT	EM3	SPT (TO-92S)	ATR	ATV	FTR	FTL
Free Air/PCB	200	200	200	150	300	300	300	300	300
Ceramic Substrate	350	350	350	250	—	—	—	—	—

DIGITAL TRANSISTOR CONSTRUCTION:

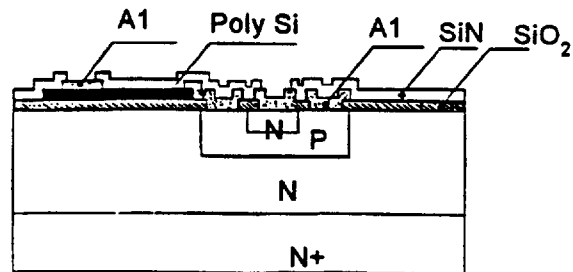
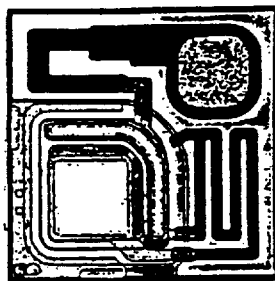

• Surface Mount Packages: Unit (mm)

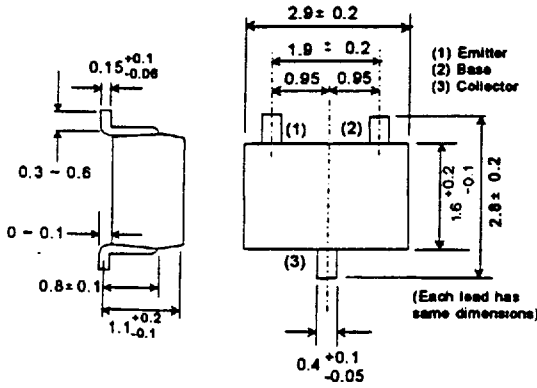

SMT (SC-59/Japanese SOT-23)

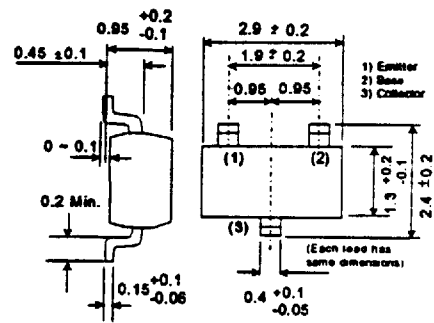

SST (European SOT-23)

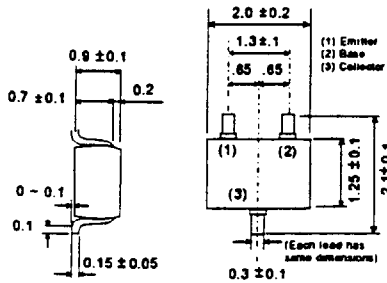

UMT

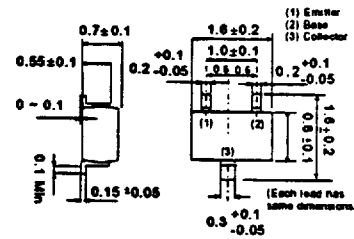

EM3

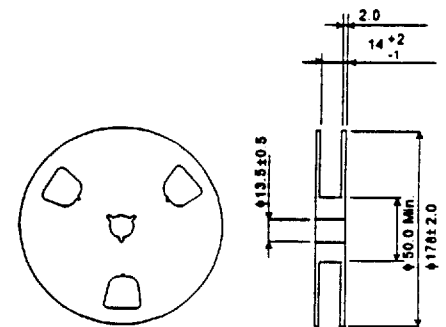
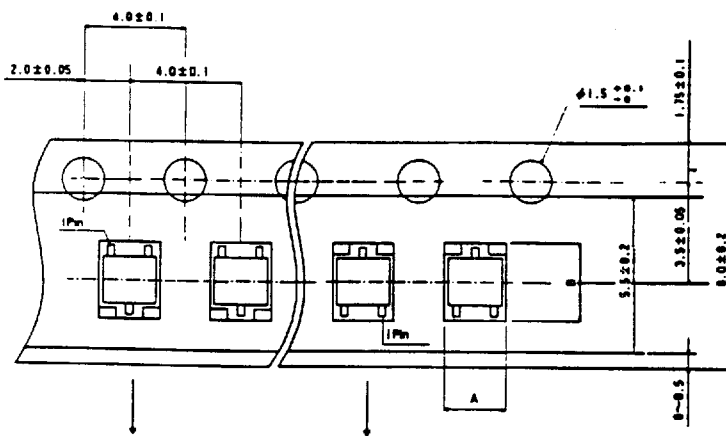

178 mm/7" Reel

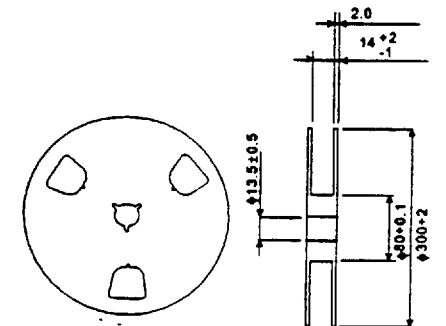

330 mm/13" Reel

Package	Code
SMT	T147
SST	T117
UMT	T107
EM3	TR

Package	Code
SMT	T146/T246
SST	T116/T216
UMT	T106/T206
EM3	TL

Package	Size		
	A	B	C
SMT	3.1 ± 0.2	3.2 ± 0.2	1.35 ± 0.1
SST	3.1 ± 0.2	2.8 ± 0.2	1.25 ± 0.2
UMT	2.2 ± 0.1	2.4 ± 0.1	1.15 ± 0.1
EM3	1.8 ± 0.1	1.8 ± 0.2	0.9 ± 0.2

Tape and Reel Dimensions

• Leaded (thru-hole) Packages

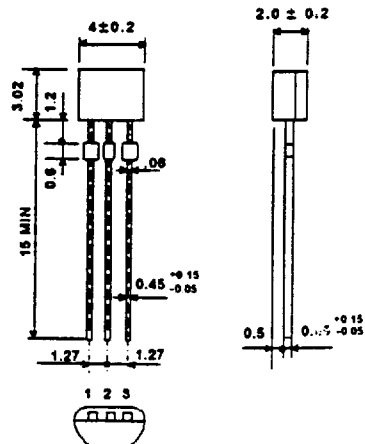

SPT(TO-92S) Package

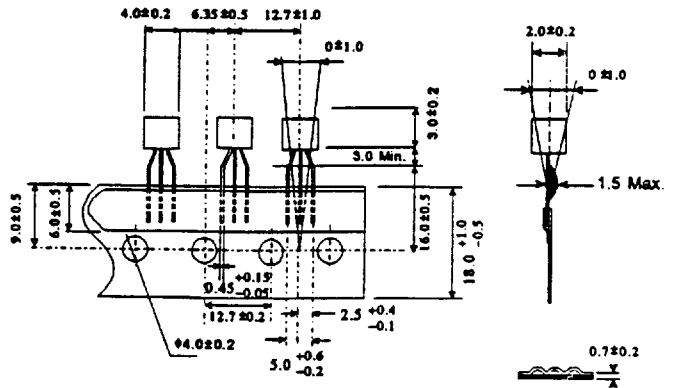

Ammo Box Taping Dimensions

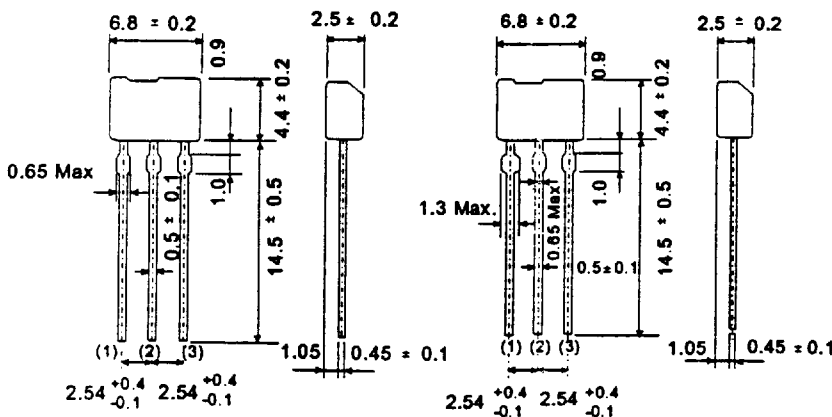

ATV(TV2 Style) Package

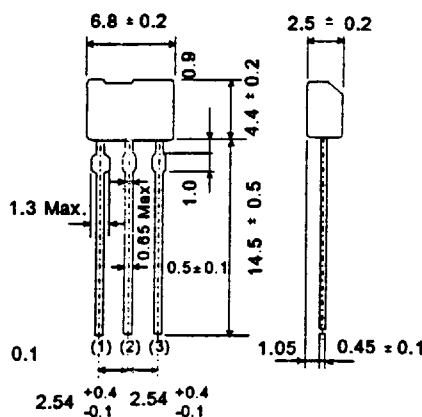

ATV(TV3 Style) Package

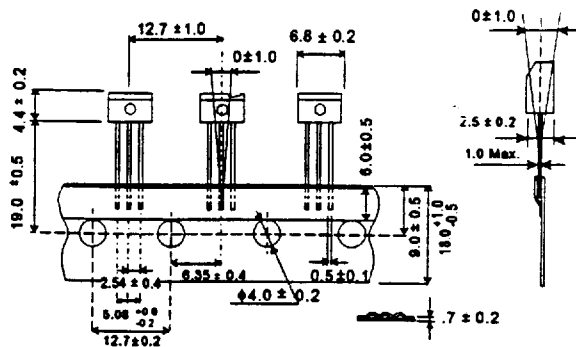

Ammo Box Taping Dimensions

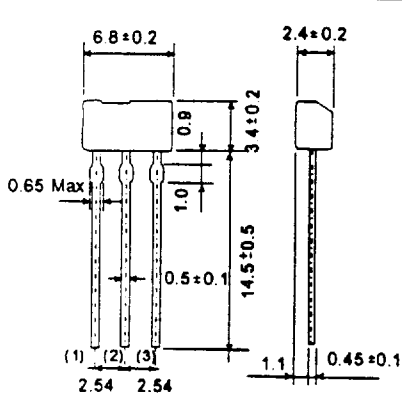

FTL(TL2 Style) Package

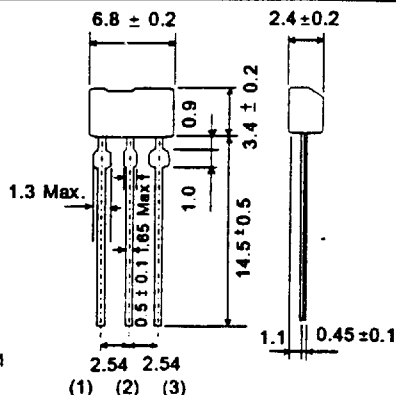

FTL(TL3 Style) Package

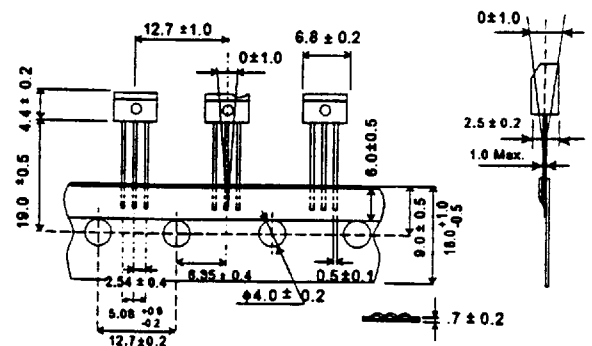

Ammo Box Taping Dimensions

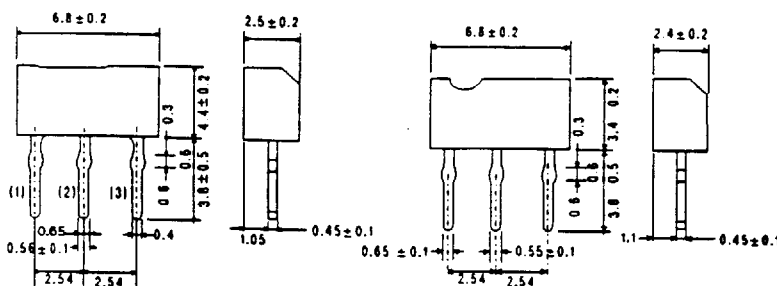

FTR Package

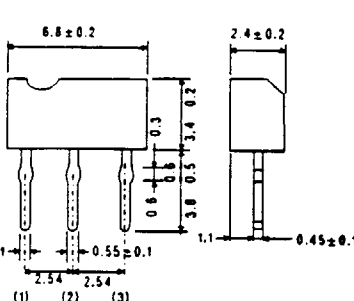

ATR Package

PKG.	TAPING CODE	DESCRIPTION	PKG. QTY.
SPT(TO-92S)	TP	AMMO BOX RADIAL (Standard)	5,000
	NONE	BULK	2,000
ATV	TV2	AMMO BOX RADIAL (Standard)	2,500
	TV3	AMMO BOX RADIAL	2,500
FTL	TL2	AMMO BOX RADIAL (Standard)	2,500
	TL3	AMMO BOX RADIAL	2,500
FTR	NONE	BULK (Standard)	2,000
	C1	TUBE	8,000
ATR	NONE	BULK (Standard)	2,000
	C2	TUBE	8,000

DIGITAL TRANSISTOR: PNP

ELECTRICAL CHARACTERISTICS: 100 mA Series

PART NUMBER	TYP	RESISTOR VALUE		R2/R1			Ic (mA)	INPUT VOLT			hFE		Icbo		Icbo		PART MARK	DIE TYPE	EQUIVALENT CIRCUIT
		R1 (K)	R2 (K)	Min	Typ	Max		Min	Max	Min	Vce (V)	Ic (mA)	Max	Vcb (V)	Max	Vce (V)			
DTA113Z	PNP	1.0	10.0	8	10	12	100	-10	5	33	5	5	0.5	50	0.5	50	E11/111	A776	
DTA114E	PNP	10.0	10.0	0.8	1	1.2	100	-40	10	30	5	5	0.5	50	0.5	50	14	A766	
DTA114W	PNP	10.0	4.7	0.37	0.47	0.57	100	-30	10	24	5	10	0.5	50	0.5	50	74	A778	
DTA114Y	PNP	10.0	47.0	3.7	4.7	5.7	100	-40	6	68	5	5	0.5	50	0.5	50	54	A762	
DTA115E*	PNP	100.0	100.0	0.8	1	1.2	100	-40	10	82	5	5	0.5	50	0.5	50	19	B861	
DTA115U	PNP	100.0	10.0	0.08	0.1	0.12	100	-40	10	27	5	5	0.5	50	0.5	50	E79/179	B865	
DTA123E	PNP	2.2	2.2	0.8	1	1.2	100	-12	10	20	5	20	0.5	50	0.5	50	12	A733	
DTA123J	PNP	2.2	47.0	17	21	26	100	-12	5	80	5	10	0.5	50	0.5	50	E32/132	A774	
DTA123Y	PNP	2.2	10.0	3.6	4.5	5.5	100	-12	5	33	5	10	0.5	50	0.5	50	52	A777	
DTA124E	PNP	22.0	22.0	0.8	1	1.2	100	-40	10	56	5	5	0.5	50	0.5	50	15	A761	
DTA124X	PNP	22.0	47.0	1.7	2.1	2.6	100	-40	10	68	5	5	0.5	50	0.5	50	35	A770	
DTA143E	PNP	4.7	4.7	0.8	1	1.2	100	-30	10	20	5	10	0.5	50	0.5	50	13	A768	
DTA143X	PNP	4.7	10.0	1.7	2.1	2.6	100	-20	7	30	5	10	0.5	50	0.5	50	33	A769	
DTA143Y	PNP	4.7	22.0	3.7	4.7	5.7	100	-30	6	58	5	5	0.5	50	0.5	50	53	A785	
DTA143Z	PNP	4.7	47.0	8	10	12	100	-30	5	80	5	10	0.5	50	0.5	50	E13/132	A775	
DTA144E	PNP	47.0	47.0	0.8	1	1.2	100	-40	15	68	5	5	0.5	50	0.5	50	16	A782	
DTA144V	PNP	47.0	10.0	0.17	0.21	0.26	100			33	5	5	0.5	50	0.5	50	E56/156	A774	
DTA144W	PNP	47.0	22.0	0.37	0.47	0.57	100	-40	10	56	5	5	0.5	50	0.5	50	76	A767	
DTA214Y	PNP	10	47	3.7	4.7	5.7	100	-40	6	68	5	5	0.5	50	0.5	50	N14	A762	
DTA1D3R	PNP	2.7	1.0	0.33	0.37	0.41	100	-15	15	20	5	30	0.5	50	0.5	50	K3B	A784	

PART NUMBER	TYP	RESISTOR VALUE		Vcbo (V)	Vceo (V)	Vebo (V)	Ic (mA)	hFE			Icbo		Icbo		PART MARK	DIE TYPE	EQUIVALENT CIRCUIT		
		R1 (K)	R2 (K)					Max	Min	Typ	Max	Vce (V)	Ic (mA)	Max				Vcb (V)	Max
DTA143T	PNP	4.7	NONE	50	50	5	100	100	250	600	5	1	0.5	50	0.5	4	93	A764	
DTA114T	PNP	10.0	NONE	50	50	5	100	100	250	600	5	1	0.5	50	0.5	4	94	A765	
DTA124T	PNP	22.0	NONE	50	50	5	100	100	250	600	5	1	0.5	50	0.5	4	95	A771	
DTA144T	PNP	47.0	NONE	50	50	5	100	100	250	600	5	1	0.5	50	0.5	4	96	A772	
DTA115T	PNP	100.0	NONE	50	50	5	100	100	250	600	5	1	0.5	50	0.5	4	99	B864	
DTA125T	PNP	200.0	NONE	50	50	5	100	100	250	600	5	1	0.5	50	0.5	4	9A	B863	
DTA113T	PNP	1.0	NONE	50	50	5	100	100	250	600	5	1	0.5	50	0.5	4	91	A786	

PART NUMBER	TYP	RESISTOR VALUE		Vcbo (V)	Vceo (V)	Vebo (V)	Ic (mA)	hFE			Icbo		Icbo		PART MARK	DIE TYPE	EQUIVALENT CIRCUIT		
		R1 (K)	R2 (K)					Max	Min	Typ	Max	Vce (V)	Ic (mA)	Max				Vcb (V)	Max
DTA114G	PNP	0	10.0	50	50	5	100	30	-	-	5	5	0.5	50	580	4	K14	A780	
DTA124G	PNP	0	22.0	50	50	5	100	56	-	-	5	5	0.5	50	280	4	K15	A781	
DTA144G	PNP	0	47.0	50	50	5	100	68	-	-	5	5	0.5	50	130	4	K16	A782	
DTA115G	PNP	0	100.0	50	50	5	100	82	-	-	5	5	0.5	50	58	4	K19	B862	
DTB114G	PNP	0	10.0	50	50	5	500	56	-	-	5	100	0.5	50	0.5	4	L14	B726	

ELECTRICAL CHARACTERISTICS: 500 mA Series

PART NUMBER	TYP	RESISTOR VALUE		R2/R1			Ic (mA)	INPUT VOLT			hFE		Icbo		Icbo		PART MARK	DIE TYPE	EQUIVALENT CIRCUIT
		R1 (K)	R2 (K)	Min	Typ	Max		Min	Max	Min	Vce (V)	Ic (mA)	Max	Vcb (V)	Max	Vce (V)			
DTB113E	PNP	1.0	1.0	0.8	1	1.2	500	-10	10	33	5	50	0.5	50	0.5	50	F11	B717	
DTB113Z	PNP	1.0	10.0	8	10	12	500	-10	5	56	5	50	0.5	50	0.5	50	G11	B718	
DTB114E	PNP	10.0	10.0	0.8	1	1.2	500	-40	10	56	5	50	0.5	50	0.5	50	F14	B714	
DTB123E	PNP	2.2	2.2	0.8	1	1.2	500	-12	10	39	5	50	0.5	50	0.5	50	F12	B712	
DTB143E	PNP	4.7	4.7	0.8	1	1.2	500	-30	10	47	5	50	0.5	50	0.5	50	F13	B713	
DTB123Y	PNP	2.2	10.0	3.6	4.5	5.5	500	-12	5	56	5	50	0.5	50	0.5	50	F52	B715	
DTB122J	PNP	0.22	4.7	17.1	21.3	25.6	500	-5	5	47	5	50	0.5	50	0.5	50	G3C	B725	
DTB133H	PNP	3.3	10.0	2.4	3	3.7	500	-20	6	56	5	50	0.5	50	0.5	50	G98	B719	

PART NUMBER	TYP	RESISTOR VALUE		Vcbo (V)	Vceo (V)	Vebo (V)	Ic (mA)	hFE			Icbo		Icbo		PART MARK	DIE TYPE	EQUIVALENT CIRCUIT		
		R1 (K)	R2 (K)					Max	Min	Typ	Max	Vce (V)	Ic (mA)	Max				Vcb (V)	Max
DTB123T	PNP	2.2	NONE	50	50	5	500	100	250	600	5	50	0.5	50	0.5	4	E92	B723	
DTB143T	PNP	4.7	NONE	50	50	5	500	100	250	600	5	50	0.5	50	0.5	4	F03	B720	
DTB163T	PNP	6.8	NONE	50	50	5	500	100	250	600	5	50	0.5	50	0.5	4	E97	B721	
DTB114T	PNP	10.0	NONE	50	50	5	500	100	250	600	5	50	0.5	50	0.5	4	E94	B722	

DIGITAL TRANSISTOR: PNP

ELECTRICAL CHARACTERISTICS: 100 mA Series

PART NUMBER	Vin(off)			Vin(on)			Vo(on)			Ib		Ic(OFF)			Vce(SAT)			Cob @ F=1MHz			CUT-OFF FREQ				
	Max (V)	Vce (V)	Ic (mA)	Min (V)	Vce (V)	Ic (mA)	TYP (V)	Max (V)	Ic (mA)	Ib (mA)	Max (mA)	Vin (V)	Max (uA)	Vcc (V)	Vin (V)	Max (V)	Ic (mA)	Ib (mA)	TYP (pF)	Max (pF)	Vcb (V)	Ie (mA)	fT (MHz)	Vce (V)	Ic (mA)
DTA113Z	0.3	5	0.1	3	0.3	20	0.1	0.3	10	0.5	7.2	5	10	30	0	0.3	5	0.25	3	6	10	0	250	10	5
DTA114E	0.5	5	0.1	3	0.3	10	0.1	0.3	10	0.5	0.88	5	10	30	0	0.3	5	0.25	3	6	10	0	250	10	5
DTA114W	0.8	5	0.1	3	0.3	2	0.1	0.3	10	0.5	0.88	5	10	30	0	0.3	5	0.25	3	6	10	0	250	10	5
DTA114Y	0.3	5	0.1	1.4	0.3	1	0.1	0.3	5	0.25	0.88	5	10	30	0	0.3	5	0.25	3	6	10	0	250	10	5
DTA115E	0.5	5	0.1	3	0.3	1	0.1	0.3	5	0.25	0.15	5	10	30	0	0.3	5	0.25	3	6	10	0	250	10	5
DTA115U	3.3	5	0.1	1.5	0.3	1	0.1	0.3	7	0.2	0.1	5	10	30	0	0.3	5	0.25	3	6	10	0	250	10	5
DTA123E	0.5	5	0.1	3	0.3	20	0.1	0.3	10	0.5	3.8	5	10	30	0	0.3	5	0.25	3	6	10	0	250	10	5
DTA123J	0.5	5	0.1	1.1	0.3	5	0.1	0.3	5	0.25	3.6	5	10	30	0	0.3	5	0.25	3	6	10	0	250	10	5
DTA123Y	0.3	5	0.1	3	0.3	20	0.1	0.3	10	0.5	3.8	5	10	30	0	0.3	5	0.25	3	6	10	0	250	10	5
DTA124E	0.5	5	0.1	3	0.2	5	0.1	0.3	10	0.5	0.36	5	10	30	0	0.3	5	0.25	3	6	10	0	250	10	5
DTA124X	0.4	5	0.1	2.5	0.3	2	0.1	0.3	10	0.5	0.36	5	10	30	0	0.3	5	0.25	3	6	10	0	250	10	5
DTA143E	0.5	5	0.1	3	0.3	20	0.1	0.3	10	0.5	1.8	5	10	30	0	0.3	5	0.25	3	6	10	0	250	10	5
DTA143X	0.3	5	0.1	2.5	0.3	20	0.1	0.3	10	0.5	1.8	5	10	30	0	0.3	5	0.25	3	6	10	0	250	10	5
DTA143Y	0.3	5	0.1	3	0.3	10	0.1	0.3	10	0.5	1.8	5	10	30	0	0.3	5	0.25	3	6	10	0	250	10	5
DTA144E	0.5	5	0.1	3	0.3	2	0.1	0.3	10	0.5	0.18	5	10	30	0	0.3	5	0.25	3	6	10	0	250	10	5
DTA144V	1.0	5	0.1	6	0.3	2	0.1	0.3	10	0.5	0.18	5	10	30	0	0.3	5	0.25	3	6	10	0	250	10	5
DTA144W	0.8	5	0.1	4	0.3	2	0.1	0.3	10	0.5	0.16	5	10	30	0	0.3	5	0.25	3	6	10	0	250	10	5
DTA214Y	0.3	5	0.1	1.4	0.3	1	0.1	0.3	50	2.5	0.88	5	10	30	0	0.3	5	0.25	3	6	10	0	250	10	5
DTA1D3R	1.5	5	0.1	4	0.3	5	0.1	0.3	10	1	3.7	5	10	30	0	0.3	5	0.25	3	6	10	0	250	10	5

PART NUMBER	Vin(off)			Vin(on)			Vo(on)			Ib		Ic(OFF)			Vce(SAT)			Cob @ F=1MHz			CUT-OFF FREQ				
	Max (V)	Vce (V)	Ic (mA)	Min (V)	Vce (V)	Ic (uA)	TYP (V)	Max (V)	Ic (mA)	Ib (mA)	Max (mA)	Vin (V)	Max (uA)	Vcc (V)	Vin (V)	Max (V)	Ic (mA)	Ib (mA)	TYP (pF)	Max (pF)	Vcb (V)	Ie (mA)	fT (MHz)	Vce (V)	Ic (mA)
DTA143T	0.3	5	0.1	3	0.3	20	0.1	0.3	10	0.5	7.2	5	10	30	0	0.3	5	0.25	3	6	10	0	250	10	5
DTA114T	0.5	5	0.1	3	0.3	10	0.1	0.3	10	0.5	0.88	5	10	30	0	0.3	10	1	3	6	10	0	250	10	5
DTA124T	0.8	5	0.1	3	0.3	2	0.1	0.3	5	0.25	1.8	5	10	30	0	0.3	5	0.5	3	6	10	0	250	10	5
DTA144T	0.3	5	0.1	1.4	0.3	1	0.1	0.3	5	0.25	0.88	5	10	30	0	0.3	5	0.5	3	6	10	0	250	10	5
DTA115T	0.5	5	0.1	3	0.3	1	0.1	0.3	5	0.25	0.15	5	10	30	0	0.3	1	0.1	3	6	10	0	250	10	5
DTA125T	0.8	5	0.1	3	0.3	1	0.1	0.3	5	0.25	0.33	5	10	30	0	0.3	0.5	0.05	3	6	10	0	250	10	5
DTA113T	0.5	5	0.1	3	0.3	20	0.1	0.3	10	0.5	3.8	5	10	30	0	0.3	5	0.2	3	6	10	0	250	10	5

PART NUMBER	Vin(off)			Vin(on)			Vo(on)			Ib		Ic(OFF)			Vce(SAT)			Cob @ F=1MHz			CUT-OFF FREQ				
	Max (V)	Vce (V)	Ic (mA)	Min (V)	Vce (V)	Ic (uA)	TYP (V)	Max (V)	Ic (mA)	Ib (mA)	Max (mA)	Vin (V)	Max (uA)	Vcc (V)	Vin (V)	Max (V)	Ic (mA)	Ib (mA)	TYP (pF)	Max (pF)	Vcb (V)	Ie (mA)	fT (MHz)	Vce (V)	Ic (mA)
DTA114G	0.3	5	0.1	3	0.3	20	0.1	0.3	10	0.5	7.2	5	10	30	0	0.3	10	0.5	3	6	10	0	250	10	5
DTA124G	0.5	5	0.1	3	0.3	10	0.1	0.3	10	0.5	0.88	5	10	30	0	0.3	10	0.5	3	6	10	0	250	10	5
DTA144G	0.8	5	0.1	3	0.3	2	0.1	0.3	5	0.25	1.8	5	10	30	0	0.3	10	0.5	3	6	10	0	250	10	5
DTA115G	0.3	5	0.1	1.4	0.3	1	0.1	0.3	5	0.25	0.88	5	10	30	0	0.3	10	0.25	3	6	10	0	250	10	5
DTB114G	0.3	5	0.1	3	0.3	20	0.1	0.3	10	0.5	7.2	5	10	30	0	0.3	50	2.5	3	6	10	0	200	10	5

ELECTRICAL CHARACTERISTICS: 500 mA Series

PART NUMBER	Vin(off)			Vin(on)			Vo(on)			Ib		Ic(OFF)			Vce(SAT)			Cob @ F=1MHz			CUT-OFF FREQ				
	Max (V)	Vce (V)	Ic (mA)	Min (V)	Vce (V)	Ic (uA)	TYP (V)	Max (V)	Ic (mA)	Ib (mA)	Max (mA)	Vin (V)	Max (uA)	Vcc (V)	Vin (V)	Max (V)	Ic (mA)	Ib (mA)	TYP (pF)	Max (pF)	Vcb (V)	Ie (mA)	fT (MHz)	Vce (V)	Ic (mA)
DTB113E	0.5	5	0.1	3	0.3	20	0.1	0.3	50	2.5	7.2	5	10	30	0	0.3	5	0.25	3	6	10	0	200	10	50
DTB113Z	0.3	5	0.1	3	0.3	20	0.1	0.3	50	2.5	7.2	5	10	30	0	0.3	5	0.25	3	6	10	0	200	10	50
DTB114E	0.5	5	0.1	3	0.3	10	0.1	0.3	50	2.5	0.88	5	10	30	0	0.3	5	0.25	3	6	10	0	200	10	50
DTB123E	0.5	5	0.1	3	0.3	20	0.1	0.3	50	2.5	3.8	5	10	30	0	0.3	5	0.25	3	6	10	0	200	10	50
DTB143E	0.5	5	0.1	3	0.3	20	0.1	0.3	50	2.5	1.8	5	10	30	0	0.3	5	0.25	3	6	10	0	200	10	50
DTB123Y	0.3	5	0.1	2	0.3	20	0.1	0.3	50	2.5	3.6	5	10	30	0	0.3	5	0.25	3	6	10	0	200	10	50
DTB122J	0.3	5	0.1	2	0.3	30	0.1	0.3	50	2.5	4.5	5	10	30	0	0.3	5	0.25	3	6	10	0	200	10	50
DTB133H	0.3	5	0.1	2	0.3	20	0.1	0.3	50	2.5	2.4	5	10	30	0	0.3	5	0.25	3	6	10	0	200	10	50

PART NUMBER	Vin(off)			Vin(on)			Vo(on)			Ib		Ic(OFF)			Vce(SAT)			Cob @ F=1MHz			CUT-OFF FREQ				
	Max (V)	Vce (V)	Ic (mA)	Min (V)	Vce (V)	Ic (uA)	TYP (V)	Max (V)	Ic (mA)	Ib (mA)	Max (mA)	Vin (V)	Max (uA)	Vcc (V)	Vin (V)	Max (V)	Ic (mA)	Ib (mA)	TYP (pF)	Max (pF)	Vcb (V)	Ie (mA)	fT (MHz)	Vce (V)	Ic (mA)
DTB123T	0.5	5	0.1	3	0.3	20	0.1	0.3	10	0.5	7.2	5	10	30	0	0.3	5	0.25	3	6	10	0	200	10	5
DTB143T	0.3	5	0.1	3	0.3	10	0.1	0.3	10	0.5	0.88	5	10	30	0	0.3	5	0.25	3	6	10	0	200	10	5
DTB163T	0.8	5	0.1	3	0.3	2	0.1	0.3	5	0.25	1.8	5	10	30	0	0.3	5	0.25	3	6	10	0	200	10	5
DTB114T	0.3	5	0.1	1.4	0.3	1	0.1	0.3	5	0.25	0.88	5	10	30	0	0.3	5	0.25	3	6	10	0	200	10	5

TRANSISTORS

DIGITAL TRANSISTOR: NPN

ELECTRICAL CHARACTERISTICS: 100 mA Series

PART NUMBER	TYP	RESISTOR VALUE		R2/R1			Ic Max (mA)	INPUT VOLT		hFE		Icbo		Icso		PART MARK	DIE TYPE	EQUIVALENT CIRCUIT	
		R1 (K)	R2 (K)	Min	Typ	Max		Min	Max	Min	Vce (V)	Ic (mA)	Max	Vcb (V)	Max				Vce (V)
DTC113Z	NPN	1.0	10.0	8	10	12	100	-10	5	33	5	5	0.5	50	0.5	50	E12/121	C776	
DTC114E	NPN	10.0	10.0	0.8	1	1.2	100	-40	10	30	5	5	0.5	50	0.5	50	24	C786	
DTC114W	NPN	10.0	4.7	0.37	0.47	0.57	100	-30	10	24	5	10	0.5	50	0.5	50	84	C778	
DTC114Y	NPN	10.0	47.0	3.7	4.7	5.7	100	-40	6	68	5	5	0.5	50	0.5	50	84	C762	
DTC115E*	NPN	100.0	100.0	0.8	1	1.2	100	-40	10	82	5	5	0.5	50	0.5	50	29	D861	
DTC115U	NPN	100.0	10.0	0.08	0.1	0.12	100	-40	10	27	5	5	0.5	50	0.5	50	E89/189	D865	
DTC123E	NPN	2.2	2.2	0.8	1	1.2	100	-12	10	20	5	20	0.5	50	0.5	50	22	C733	
DTC123J	NPN	2.2	47.0	17	21	26	100	-12	5	80	5	10	0.5	50	0.5	50	E42/142	C774	
DTC123Y	NPN	2.2	10.0	3.6	4.5	5.5	100	-12	5	33	5	10	0.5	50	0.5	50	62	C777	
DTC124E	NPN	22.0	22.0	0.8	1	1.2	100	-40	10	56	5	5	0.5	50	0.5	50	25	C781	
DTC124X	NPN	22.0	47.0	1.7	2.1	2.6	100	-40	10	68	5	5	0.5	50	0.5	50	45	C770	
DTC143E	NPN	4.7	4.7	0.8	1	1.2	100	-30	10	20	5	10	0.5	50	0.5	50	23	C768	
DTC143X	NPN	4.7	10.0	1.7	2.1	2.6	100	-20	7	30	5	10	0.5	50	0.5	50	43	C769	
DTC143Y	NPN	4.7	22.0	3.7	4.7	5.7	100	-30	6	56	5	5	0.5	50	0.5	50	63	C785	
DTC143Z	NPN	4.7	47.0	8	10	12	100	-30	5	80	5	10	0.5	50	0.5	50	E23/123	C775	
DTC144E	NPN	47.0	47.0	0.8	1	1.2	100	-40	15	68	5	5	0.5	50	0.5	50	26	C782	
DTC144V	NPN	47.0	10.0	0.17	0.21	0.26	100			33	5	5	0.5	50	0.5	50	E66/166	C774	
DTC144W	NPN	47.0	22.0	0.37	0.47	0.57	100	-40	10	56	5	5	0.5	50	0.5	50	86	C767	
DTC214Y	NPN	10	47	3.7	4.7	5.7	100	-40	6	68	5	5	0.5	50	0.5	50	N24	C762	
DTC1D3R	NPN	2.7	1.0	0.33	0.37	0.41	100	-15	15	20	5	30	0.5	50	0.5	50	K4B	C784	

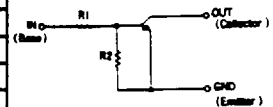

PART NUMBER	TYP	RESISTOR VALUE		Vcbo Max (V)	Vceo Max (V)	Vebo Max (V)	Ic Max (mA)	INPUT VOLT		hFE		Icbo		Icso		PART MARK	DIE TYPE	EQUIVALENT CIRCUIT	
		R1 (K)	R2 (K)					Min	Typ	Max	Vce (V)	Ic (mA)	Max	Vcb (V)	Max				Vce (V)
DTC143T	NPN	4.7	NONE	50	50	5	100	100	250	600	5	1	0.5	50	0.5	4	3	C764	
DTC114T	NPN	10.0	NONE	50	50	5	100	100	250	600	5	1	0.5	50	0.5	4	4	C785	
DTC124T	NPN	22.0	NONE	50	50	5	100	100	250	600	5	1	0.5	50	0.5	4	5	C771	
DTC144T	NPN	47.0	NONE	50	50	5	100	100	250	600	5	1	0.5	50	0.5	4	6	C772	
DTC115T	NPN	100.0	NONE	50	50	5	100	100	250	600	5	1	0.5	50	0.5	4	9	D864	
DTC125T	NPN	200.0	NONE	50	50	5	100	100	250	600	5	1	0.5	50	0.5	4	0A	D863	
DTC113T	NPN	1.0	NONE	50	50	5	100	100	250	600	5	1	0.5	50	0.5	4	1	C786	

PART NUMBER	TYP	RESISTOR VALUE		Vcbo Max (V)	Vceo Max (V)	Vebo Max (V)	Ic Max (mA)	INPUT VOLT		hFE		Icbo		Icso		PART MARK	DIE TYPE	EQUIVALENT CIRCUIT	
		R1 (K)	R2 (K)					Min	Typ	Max	Vce (V)	Ic (mA)	Max	Vcb (V)	Max				Vce (V)
DTC114G	NPN	0	10.0	50	50	5	100	30	-	-	5	5	0.5	50	580	4	K24	C780	
DTC124G	NPN	0	22.0	50	50	5	100	56	-	-	5	5	0.5	50	260	4	K25	C781	
DTC144G	NPN	0	47.0	50	50	5	100	68	-	-	5	5	0.5	50	130	4	K26	C782	
DTC115G	NPN	0	100.0	50	50	5	100	82	-	-	5	5	0.5	50	58	4	K29	D862	
DTD114G	NPN	0	10.0	50	50	5	500	56	-	-	5	100	0.5	50	0.5	4	L24	D726	

ELECTRICAL CHARACTERISTICS: 500 mA Series

PART NUMBER	TYP	RESISTOR VALUE		R2/R1			Ic Max (mA)	INPUT VOLT		hFE		Icbo		Icso		PART MARK	DIE TYPE	EQUIVALENT CIRCUIT	
		R1 (K)	R2 (K)	Min	Typ	Max		Min	Max	Min	Vce (V)	Ic (mA)	Max	Vcb (V)	Max				Vce (V)
DTD113E	NPN	1.0	1.0	0.8	1	1.2	500	-10	10	33	5	50	0.5	50	0.5	50	F21	D717	
DTD113Z	NPN	1.0	10.0	8	10	12	500	-10	5	56	5	50	0.5	50	0.5	50	G21	D718	
DTD114E	NPN	10.0	10.0	0.8	1	1.2	500	-40	10	56	5	50	0.5	50	0.5	50	F24	D714	
DTD123E	NPN	2.2	2.2	0.8	1	1.2	500	-12	10	39	5	50	0.5	50	0.5	50	F22	D712	
DTD143E	NPN	4.7	4.7	0.8	1	1.2	500	-30	10	47	5	50	0.5	50	0.5	50	F23	D713	
DTD123Y	NPN	2.2	10.0	3.6	4.5	5.5	500	-12	5	56	5	50	0.5	50	0.5	50	F62	D715	
DTD122J	NPN	0.22	4.7	17.1	21.3	25.6	500	-5	5	47	5	50	0.5	50	0.5	50	G4C	D725	
DTD133H	NPN	3.3	10.0	2.4	3	3.7	500	-20	6	56	5	50	0.5	50	0.5	50	G08	D719	

PART NUMBER	TYP	RESISTOR VALUE		Vcbo Max (V)	Vceo Max (V)	Vebo Max (V)	Ic Max (mA)	INPUT VOLT		hFE		Icbo		Icso		PART MARK	DIE TYPE	EQUIVALENT CIRCUIT	
		R1 (K)	R2 (K)					Min	Typ	Max	Vce (V)	Ic (mA)	Max	Vcb (V)	Max				Vce (V)
DTD123T	NPN	2.2	NONE	50	50	5	500	100	250	600	5	50	0.5	50	0.5	4	E02	D723	
DTD143T	NPN	4.7	NONE	50	50	5	500	100	250	600	5	50	0.5	50	0.5	4	F13	D720	
DTD163T	NPN	6.8	NONE	50	50	5	500	100	250	600	5	50	0.5	50	0.5	4	E07	D721	
DTD114T	NPN	10.0	NONE	50	50	5	500	100	250	600	5	50	0.5	50	0.5	4	E04	D722	

DIGITAL TRANSISTOR: NPN

ELECTRICAL CHARACTERISTICS: 100 mA Series

PART NUMBER	Vin(off)			Vin(on)			Vo(on)				Ib		Ic(OFF)			Vce(SAT)			Cob @ F=1MHz				CUT-OFF FREQ		
	Max (V)	Vce (V)	Ic (mA)	Min (V)	Vce (V)	Ic (mA)	TYP (V)	Max (V)	Ic (mA)	Ib (mA)	Max (mA)	Vin (V)	Max (uA)	Vcc (V)	Vin (V)	Max (V)	Ic (mA)	Ib (mA)	TYP (pF)	Max (pF)	Vcb (V)	Ie (mA)	fT (MHz)	Vce (V)	Ic (mA)
DTC113Z	0.3	5	0.1	3	0.3	20	0.1	0.3	10	0.5	7.2	5	10	30	0	0.3	5	0.25	3	6	10	0	250	10	5
DTC114E	0.5	5	0.1	3	0.3	10	0.1	0.3	10	0.5	0.88	5	10	30	0	0.3	5	0.25	3	6	10	0	250	10	5
DTC114W	0.8	5	0.1	3	0.3	2	0.1	0.3	10	0.5	0.88	5	10	30	0	0.3	5	0.25	3	6	10	0	250	10	5
DTC114Y	0.3	5	0.1	1.4	0.3	1	0.1	0.3	5	0.25	0.88	5	10	30	0	0.3	5	0.25	3	6	10	0	250	10	5
DTC115E	0.5	5	0.1	3	0.3	1	0.1	0.3	5	0.25	0.15	5	10	30	0	0.3	5	0.25	3	6	10	0	250	10	5
DTC115U	3.3	5	0.1	1.5	0.3	1	0.1	0.3	7	0.2	0.1	5	10	30	0	0.3	5	0.25	3	6	10	0	250	10	5
DTC123E	0.5	5	0.1	3	0.3	20	0.1	0.3	10	0.5	3.8	5	10	30	0	0.3	5	0.25	3	6	10	0	250	10	5
DTC123J	0.5	5	0.1	1.1	0.3	5	0.1	0.3	5	0.25	3.8	5	10	30	0	0.3	5	0.25	3	6	10	0	250	10	5
DTC123Y	0.3	5	0.1	3	0.3	20	0.1	0.3	10	0.5	3.8	5	10	30	0	0.3	5	0.25	3	6	10	0	250	10	5
DTC124E	0.5	5	0.1	3	0.2	5	0.1	0.3	10	0.5	0.36	5	10	30	0	0.3	5	0.25	3	6	10	0	250	10	5
DTC124X	0.4	5	0.1	2.5	0.3	2	0.1	0.3	10	0.5	0.36	5	10	30	0	0.3	5	0.25	3	6	10	0	250	10	5
DTC143E	0.5	5	0.1	3	0.3	20	0.1	0.3	10	0.5	1.8	5	10	30	0	0.3	5	0.25	3	6	10	0	250	10	5
DTC143X	0.3	5	0.1	2.5	0.3	20	0.1	0.3	10	0.5	1.8	5	10	30	0	0.3	5	0.25	3	6	10	0	250	10	5
DTC143Y	0.3	5	0.1	3	0.3	10	0.1	0.3	10	0.5	1.8	5	10	30	0	0.3	5	0.25	3	6	10	0	250	10	5
DTC144Z	0.5	5	0.1	1.3	0.3	5	0.1	0.3	5	0.25	1.8	5	10	30	0	0.3	5	0.25	3	6	10	0	250	10	5
DTC144E	0.5	5	0.1	3	0.3	2	0.1	0.3	10	0.5	0.18	5	10	30	0	0.3	5	0.25	3	6	10	0	250	10	5
DTC144V	1.0	5	0.1	6	0.3	2	0.1	0.3	10	0.5	0.16	5	10	30	0	0.3	5	0.25	3	6	10	0	250	10	5
DTC144W	0.8	5	0.1	4	0.3	2	0.1	0.3	10	0.5	0.16	5	10	30	0	0.3	5	0.25	3	6	10	0	250	10	5
DTC214Y	0.3	5	0.1	1.4	0.3	1	0.1	0.3	50	2.5	0.88	5	10	30	0	0.3	5	0.25	3	6	10	0	250	10	5
DTC1D3R	1.5	5	0.1	4	0.3	5	0.1	0.3	10	1	3.7	5	10	30	0	0.3	5	0.25	3	6	10	0	250	10	5

PART NUMBER	Vin(off)			Vin(on)			Vo(on)				Ib		Ic(OFF)			Vce(SAT)			Cob @ F=1MHz				CUT-OFF FREQ		
	Max (V)	Vce (V)	Ic (mA)	Min (V)	Vce (V)	Ic (uA)	TYP (V)	Max (V)	Ic (mA)	Ib (mA)	Max (mA)	Vin (V)	Max (uA)	Vcc (V)	Vin (V)	Max (V)	Ic (mA)	Ib (mA)	TYP (pF)	Max (pF)	Vcb (V)	Ie (mA)	fT (MHz)	Vce (V)	Ic (mA)
DTC143T	0.3	5	0.1	3	0.3	20	0.1	0.3	10	0.5	7.2	5	10	30	0	0.3	5	0.25	3	6	10	0	250	10	5
DTC114T	0.5	5	0.1	3	0.3	10	0.1	0.3	10	0.5	0.88	5	10	30	0	0.3	10	1	3	6	10	0	250	10	5
DTC124T	0.8	5	0.1	3	0.3	2	0.1	0.3	5	0.25	1.8	5	10	30	0	0.3	5	0.5	3	6	10	0	250	10	5
DTC144T	0.3	5	0.1	1.4	0.3	1	0.1	0.3	5	0.25	0.88	5	10	30	0	0.3	5	0.5	3	6	10	0	250	10	5
DTC115T	0.5	5	0.1	3	0.3	1	0.1	0.3	5	0.25	0.15	5	10	30	0	0.3	1	0.1	3	6	10	0	250	10	5
DTC125T	0.8	5	0.1	3	0.3	1	0.1	0.3	5	0.25	0.33	5	10	30	0	0.3	0.5	0.05	3	6	10	0	250	10	5
DTC113T	0.5	5	0.1	3	0.3	20	0.1	0.3	10	0.5	3.8	5	10	30	0	0.3	5	0.2	3	6	10	0	250	10	5

PART NUMBER	Vin(off)			Vin(on)			Vo(on)				Ib		Ic(OFF)			Vce(SAT)			Cob @ F=1MHz				CUT-OFF FREQ		
	Max (V)	Vce (V)	Ic (mA)	Min (V)	Vce (V)	Ic (uA)	TYP (V)	Max (V)	Ic (mA)	Ib (mA)	Max (mA)	Vin (V)	Max (uA)	Vcc (V)	Vin (V)	Max (V)	Ic (mA)	Ib (mA)	TYP (pF)	Max (pF)	Vcb (V)	Ie (mA)	fT (MHz)	Vce (V)	Ic (mA)
DTC114G	0.3	5	0.1	3	0.3	20	0.1	0.3	10	0.5	7.2	5	10	30	0	0.3	10	0.5	3	6	10	0	250	10	5
DTC124G	0.5	5	0.1	3	0.3	10	0.1	0.3	10	0.5	0.88	5	10	30	0	0.3	10	0.5	3	6	10	0	250	10	5
DTC144G	0.8	5	0.1	3	0.3	2	0.1	0.3	5	0.25	1.8	5	10	30	0	0.3	10	0.5	3	6	10	0	250	10	5
DTC115G	0.3	5	0.1	1.4	0.3	1	0.1	0.3	5	0.25	0.88	5	10	30	0	0.3	10	0.25	3	6	10	0	250	10	5
DTD114G	0.3	5	0.1	3	0.3	20	0.1	0.3	10	0.5	7.2	5	10	30	0	0.3	50	2.5	3	6	10	0	200	10	5

ELECTRICAL CHARACTERISTICS: 500 mA Series

PART NUMBER	Vin(off)			Vin(on)			Vo(on)				Ib		Ic(OFF)			Vce(SAT)			Cob @ F=1MHz				CUT-OFF FREQ		
	Max (V)	Vce (V)	Ic (mA)	Min (V)	Vce (V)	Ic (uA)	TYP (V)	Max (V)	Ic (mA)	Ib (mA)	Max (mA)	Vin (V)	Max (uA)	Vcc (V)	Vin (V)	Max (V)	Ic (mA)	Ib (mA)	TYP (pF)	Max (pF)	Vcb (V)	Ie (mA)	fT (MHz)	Vce (V)	Ic (mA)
DTD113E	0.5	5	0.1	3	0.3	20	0.1	0.3	50	2.5	7.2	5	10	30	0	0.3	5	0.25	3	6	10	0	200	10	50
DTD113Z	0.3	5	0.1	3	0.3	20	0.1	0.3	50	2.5	7.2	5	10	30	0	0.3	5	0.25	3	6	10	0	200	10	50
DTD114E	0.5	5	0.1	3	0.3	10	0.1	0.3	50	2.5	0.88	5	10	30	0	0.3	5	0.25	3	6	10	0	200	10	50
DTD123E	0.5	5	0.1	3	0.3	20	0.1	0.3	50	2.5	3.8	5	10	30	0	0.3	5	0.25	3	6	10	0	200	10	50
DTD143E	0.5	5	0.1	3	0.3	20	0.1	0.3	50	2.5	1.8	5	10	30	0	0.3	5	0.25	3	6	10	0	200	10	50
DTD123Y	0.3	5	0.1	2	0.3	20	0.1	0.3	50	2.5	3.6	5	10	30	0	0.3	5	0.25	3	6	10	0	200	10	50
DTD122J	0.3	5	0.1	2	0.3	30	0.1	0.3	50	2.5	4.5	5	10	30	0	0.3	5	0.25	3	6	10	0	200	10	50
DTD133H	0.3	5	0.1	2	0.3	20	0.1	0.3	50	2.5	2.4	5	10	30	0	0.3	5	0.25	3	6	10	0	200	10	50

PART NUMBER	Vin(off)			Vin(on)			Vo(on)				Ib		Ic(OFF)			Vce(SAT)			Cob @ F=1MHz				CUT-OFF FREQ		
	Max (V)	Vce (V)	Ic (mA)	Min (V)	Vce (V)	Ic (uA)	TYP (V)	Max (V)	Ic (mA)	Ib (mA)	Max (mA)	Vin (V)	Max (uA)	Vcc (V)	Vin (V)	Max (V)	Ic (mA)	Ib (mA)	TYP (pF)	Max (pF)	Vcb (V)	Ie (mA)	fT (MHz)	Vce (V)	Ic (mA)
DTD123T	0.3	5	0.1	3	0.3	20	0.1	0.3	10	0.5	7.2	5	10	30	0	0.3	5	0.25	3	6	10	0	200	10	5
DTD143T	0.5	5	0.1	3	0.3	10	0.1	0.3	10	0.5	0.88	5	10	30	0	0.3	5	0.25	3	6	10	0	200	10	5
DTD163T	0.8	5	0.1	3	0.3	2	0.1	0.3	5	0.25	1.8	5	10	30	0	0.3	5	0.25	3	6	10	0	200	10	5
DTD114T	0.3	5	0.1	1.4	0.3	1	0.1	0.3	5	0.25	0.88	5	10	30	0	0.3	5	0.25	3	6	10	0	200	10	5

• Digital Transistor Summary Table

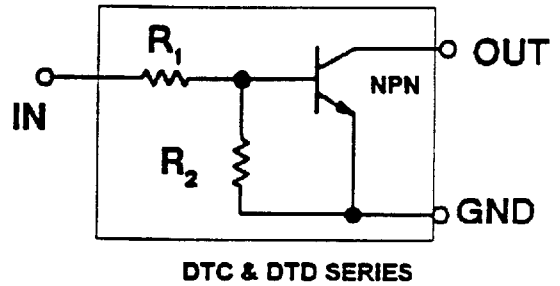
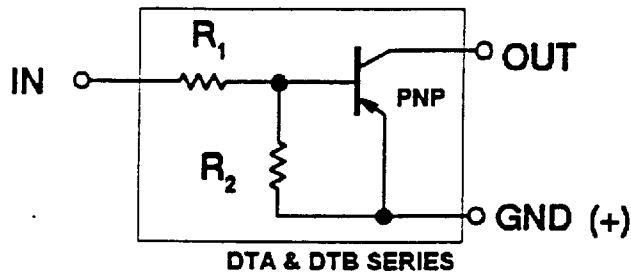

Resistor Values		PNP $I_c(\text{Max}) = 100 \text{ mA}$ 2N3906	PNP $I_c(\text{Max}) = 500 \text{ mA}$ PN2907A/2N4403	NPN $I_c(\text{Max}) = 100 \text{ mA}$ 2N3904	NPN $I_c(\text{Max}) = 500 \text{ mA}$ PN2222A/2N4401
R_1	R_2				
1/K	1K	-	DTB 113E	-	DTD 113E
1/K	NONE	DTA 113T	-	-	-
1/K	10K	DTA 113Z	DTB 113Z	DTC 113Z	DTD 113Z
10K	10K	DTA 114E	DTB 114E	DTC 114E	DTD 114E
0	10K	DTA 114G	-	DTC 114G	DTD 114G
10K	NONE	DTA 114T	DTB 114T	DTC 114T/DTC 314T *	DTD 114T
10K	4.7K	DTA 114W	-	DTC 114W	-
10K	47K	DTA 114Y/DTA 214Y	-	DTC 114Y	-
100K	100K	DTA 115E	-	DTC 115E	-
0	100K	DTA 115G	-	DTC 115G	-
100K	NONE	DTA 115T	-	DTC 115T	-
100K	10K	DTA 115U	-	DTC 115U	-
.22K	4.7K	-	DTB 122J	-	DTD 122J
2.2K	2.2K	DTA 123E	DTB 123E	DTC 123E	DTD 123E
2.2K	NONE	-	DTB 123T	DTC 323T *	DTD 123T
2.2K	47K	DTA 123J	-	DTC 123J	-
2.2K	10K	DTA 123Y	DTB 123Y	DTC 123Y	DTD 123Y
2.7K	1K	DTA 1D3R	-	DTC 1D3R	-
22K	22K	DTA 124E	-	DTC 124E	-
0	22K	DTA 124G	-	DTC 124G	-
22K	NONE	DTA 124T	-	DTC 124T	-
22K	47K	DTA 124X	-	DTC 124X	-
220K	NONE	DTA 125T	-	DTC 125T	-
3.3K	10K	-	DTB 133H	-	DTD 133H
4.7K	4.7K	DTA 143E	DTB 143E	DTC 143E	DTD 143E
4.7K	NONE	DTA 143T	DTB 143T	DTC 143T/DTC 343T *	DTD 143T
4.7K	10K	DTA 143X	-	DTC 143X	-
4.7K	22K	DTA 143Y	-	DTC 143Y	-
4.7K	47K	DTA 143Z	-	DTC 143Z	-
47K	47K	DTA 144E	-	DTC 144E	-
0	47K	DTA 144G	-	DTC 144G	-
47K	NONE	DTA 144T	-	DTC 144T	-
47K	10K	DTA 144V	-	DTC 144V	-
47K	22K	DTA 144W	-	DTC 144W	-
6.8K	6.8K	-	-	DTC 363E *	-
6.8K	NONE	-	DTB 163T	DTC 363T *	DTD 163T

* $I_c = 600 \text{ mA}$

NOTE: See "How to Order" for complete part number --

• Digital Transistors

HOW TO ORDER:

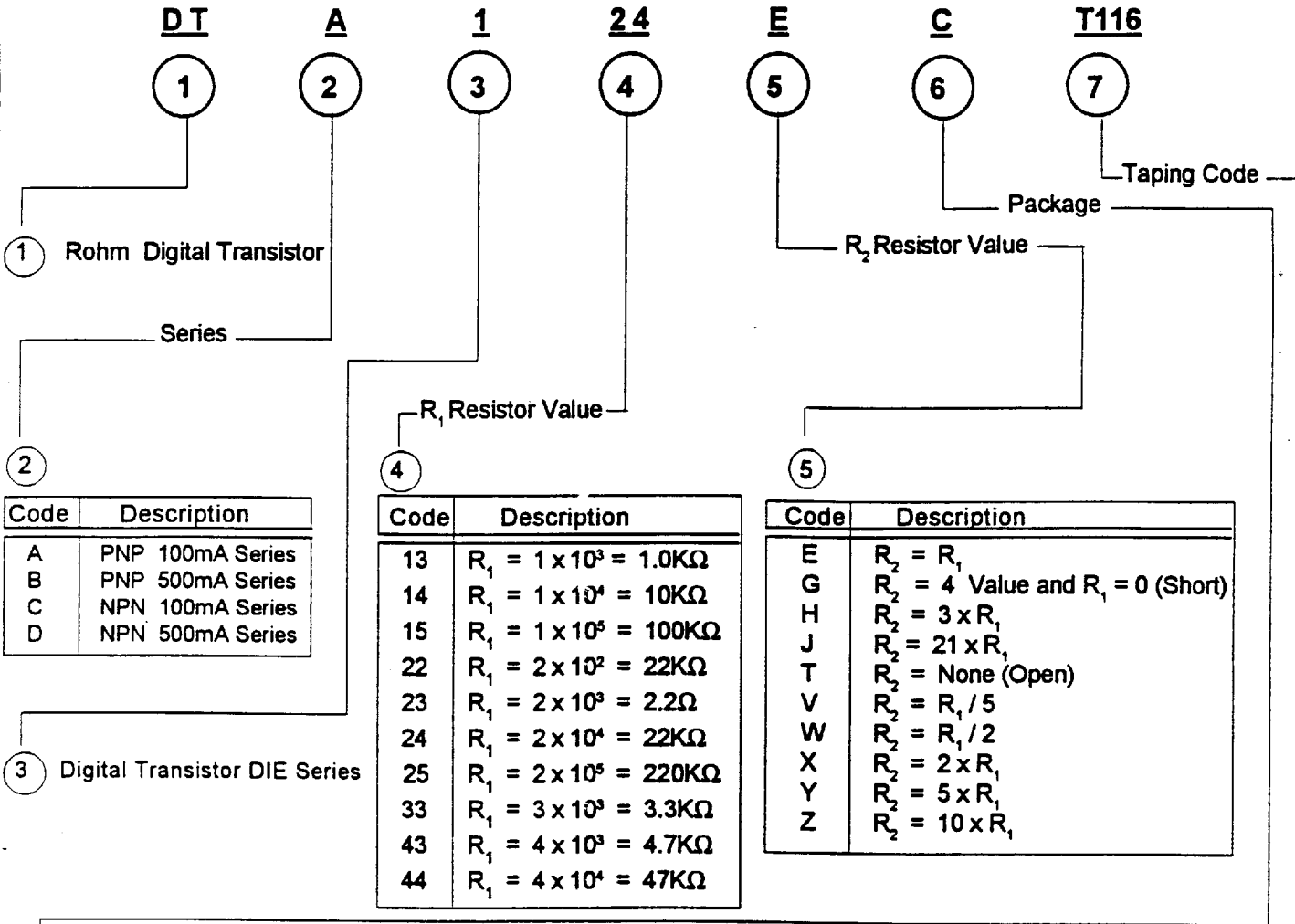

Code	Description
A	PNP 100mA Series
B	PNP 500mA Series
C	NPN 100mA Series
D	NPN 500mA Series

Code	Description
13	$R_1 = 1 \times 10^3 = 1.0K\Omega$
14	$R_1 = 1 \times 10^4 = 10K\Omega$
15	$R_1 = 1 \times 10^5 = 100K\Omega$
22	$R_1 = 2 \times 10^2 = 22K\Omega$
23	$R_1 = 2 \times 10^3 = 2.2\Omega$
24	$R_1 = 2 \times 10^4 = 22K\Omega$
25	$R_1 = 2 \times 10^5 = 220K\Omega$
33	$R_1 = 3 \times 10^3 = 3.3K\Omega$
43	$R_1 = 4 \times 10^3 = 4.7K\Omega$
44	$R_1 = 4 \times 10^4 = 47K\Omega$

Code	Description
E	$R_2 = R_1$
G	$R_2 = 4$ Value and $R_1 = 0$ (Short)
H	$R_2 = 3 \times R_1$
J	$R_2 = 21 \times R_1$
T	$R_2 = \text{None}$ (Open)
V	$R_2 = R_1 / 5$
W	$R_2 = R_1 / 2$
X	$R_2 = 2 \times R_1$
Y	$R_2 = 5 \times R_1$
Z	$R_2 = 10 \times R_1$

	PKG	DESCRIPTION	TAPING CODE	DESCRIPTION	PKG. QTY.	PACKAGE SIZE
SURFACE MOUNT	K	SMT (SC-59/JAPANESE SOT-23)	* T146	1 PIN SIDE ON FEED HOLE SIDE	3,000	178mm/7" Reel
			* T147	2 PIN SIDE ON FEED HOLD SIDE	3,000	178mm/7" Reel
			* T246	1 PIN SIDE ON FEED HOLE SIDE	10,000	330mm/13" Reel
	C	SST (EUROPEAN SOT-23)	* T116 * T117 * T216	1 PIN SIDE ON FEED HOLE SIDE 2 PIN SIDE ON FEED HOLE SIDE 1 PIN SIDE ON FEED HOLE SIDE	3,000 3,000 10,000	178mm/7" Reel 178mm/7" Reel 330 mm/13" Reel
U	UMT (DTA & DTC ONLY)	* T106 T107	1 PIN SIDE ON FEED HOLE SIDE	3,000	178 mm/7" Reel	
			2 PIN SIDE ON FEED HOLE SIDE	3,000	178 mm/7" Reel	
E	EM3 (DTA & DTC ONLY)	* TL TR	1 PIN SIDE ON FEED HOLE SIDE 2 PIN SIDE ON FEED HOLE SIDE	3,000 3,000	178 mm/7" Reel 178 mm/7" Reel	
LEADED DEVICES	S	SPT (Short TO-92)	* TP NONE	AMMO BOX RADIAL BULK	5,000 2,000	W-335/H-135/D-40(mm) Polyethylene Bag
	V	ATV	* TV2 TV3	AMMO BOX RADIAL AMMO BOX RADIAL	2,500 2,500	W-334/H-280/D-41(mm) W-334/H-280/D-41(mm)
	L	FTL	* TL2 TL3	AMMO BOX RADIAL AMMO BOX RADIAL	2,500 2,500	W-334/H-280/D-41(mm) W-334/H-280/D-41(mm)
	F	FTR	* NONE C1	BULK TUBE	2,000 8,000	Polyethylene Bag L-565/W-4.2/H-11.5(mm)
	A	ATR	* NONE C2	BULK TUBE	2,000 8,000	Polyethylene Bag L-565/W-4.2/H-12.6(mm)

Note: SOT-23, SC-59 and SPT packages are standard products.

* Standard Taping Codes