

H11AA1-M

H11AA2-M

H11AA3-M

H11AA4-M

PACKAGE

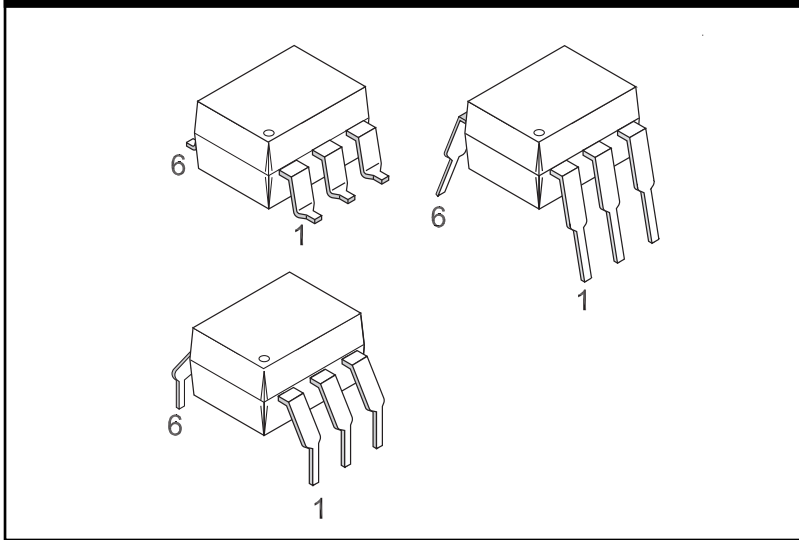

SCHEMATIC

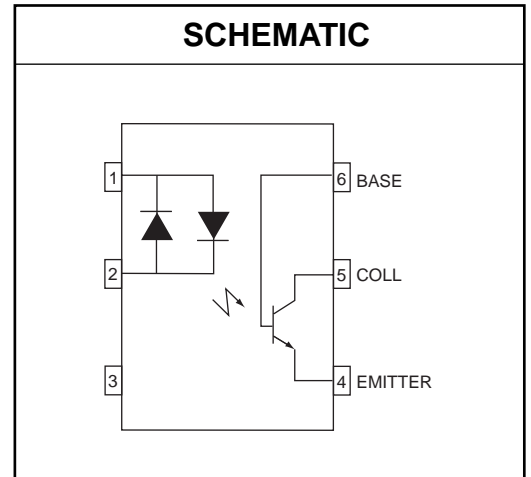

DESCRIPTION

The H11AAX-M series consists of two gallium-arsenide infrared emitting diodes connected in inverse parallel driving a single silicon phototransistor output.

FEATURES

- Bi-polar emitter input
- Built-in reverse polarity input protection
- Underwriters Laboratory (UL) recognized File #E90700, Volume 2
- VDE approved File #102497 (ordering option 'V')

APPLICATIONS

- AC line monitor
- Unknown polarity DC sensor
- Telephone line interface

H11AA1-M

H11AA2-M

H11AA3-M

H11AA4-M

ABSOLUTE MAXIMUM RATINGS ($T_A = 25^\circ\text{C}$ Unless otherwise specified)

Parameter	Symbol	Device	Value	Units
TOTAL DEVICE				
Storage Temperature	T_{STG}	All	-40 to +150	$^\circ\text{C}$
Operating Temperature	T_{OPR}	All	-40 to +100	$^\circ\text{C}$
Lead Solder Temperature	T_{SOL}	All	260 for 10 sec	$^\circ\text{C}$
Total Device Power Dissipation Derate Linearly From 25°C	P_D	All	250	mW
			2.94	mW/ $^\circ\text{C}$
EMITTER				
Continuous Forward Current	I_F	All	60	mA
Forward Current – Peak (1 μs pulse, 300 pps)	$I_F(\text{pk})$	All	± 1.0	A
LED Power Dissipation Derate Linearly From 25°C	P_D	All	120	mW
			1.41	mW/ $^\circ\text{C}$
DETECTOR				
Continuous Collector Current	I_C	All	50	mA
Detector Power Dissipation Derate linearity from 25°C	P_D	All	150	mW
			1.76	mW/ $^\circ\text{C}$

ELECTRICAL CHARACTERISTICS ($T_A = 25^\circ\text{C}$ Unless otherwise specified.)

INDIVIDUAL COMPONENT CHARACTERISTICS

Parameter	Test Conditions	Symbol	Device	Min	Typ*	Max	Unit		
EMITTER									
Input Forward Voltage	$I_F = \pm 10 \text{ mA}$	V_F	All		1.17	1.5	V		
Capacitance	$V_F = 0 \text{ V}, f = 1.0 \text{ MHz}$	C_J	All		80		pF		
DETECTOR									
Breakdown Voltage Collector to Emitter	$I_C = 1.0 \text{ mA}, I_F = 0$	BV_{CEO}	All	30	100		V		
Collector to Base	$I_C = 100 \mu\text{A}, I_F = 0$	BV_{CBO}	All	70	120		V		
Emitter to Base	$I_E = 100 \mu\text{A}, I_F = 0$	BV_{EBO}	All	5	10		V		
Emitter to Collector	$I_E = 100 \mu\text{A}, I_F = 0$	BV_{ECO}	All	7	10		V		
Leakage Current Collector to Emitter	$V_{CE} = 10 \text{ V}, I_F = 0$	I_{CEO}	H11AA1,3,4(-M)		1	50	nA		
			H11AA2-M		1	200			
Capacitance	$V_{CE} = 0, f = 1 \text{ MHz}$	C_{CE}	All		10		pF		
				C_{CB}	All		80		pF
						C_{EB}	All		15

*Typical values at $T_A = 25^\circ\text{C}$

H11AA1-M

H11AA2-M

H11AA3-M

H11AA4-M

TRANSFER CHARACTERISTICS ($T_A = 25^\circ\text{C}$ Unless otherwise specified.)							
Characteristics	Test Conditions	Symbol	Device	Min	Typ*	Max	Units
Current Transfer Ratio, Collector to Emitter	$I_F = \pm 10 \text{ mA}, V_{CE} = 10 \text{ V}$	CTR_{CE}	H11AA4-M	100			%
			H11AA3-M	50			
			H11AA1-M	20			
			H11AA2-M	10			
Current Transfer Ratio, Symmetry	$I_F = \pm 10 \text{ mA}, V_{CE} = 10 \text{ V}$ (Figure 11)		All	.33		3.0	
Saturation Voltage Collector to Emitter	$I_F = \pm 10 \text{ mA}, I_{CE} = 0.5 \text{ mA}$	$V_{CE(SAT)}$	All			.40	V

ISOLATION CHARACTERISTICS						
Characteristic	Test Conditions	Symbol	Min	Typ*	Max	Units
Package Capacitance input/output	$V_{I-O} = 0, f = 1 \text{ MHz}$	C_{I-O}		0.7		pF
Isolation Voltage	$f = 60 \text{ Hz}, t = 1 \text{ sec.}$	V_{ISO}	7500			Vac(pk)
Isolation Resistance	$V_{I-O} = 500 \text{ VDC}$	R_{ISO}	10^{11}			Ω

*Typical values at $T_A = 25^\circ\text{C}$

H11AA1-M

H11AA2-M

H11AA3-M

H11AA4-M

Fig. 1 Input Voltage vs. Input Current

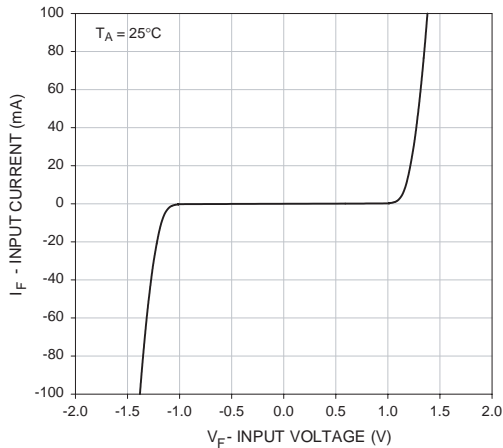

Fig. 2 Normalized CTR vs. Forward Current

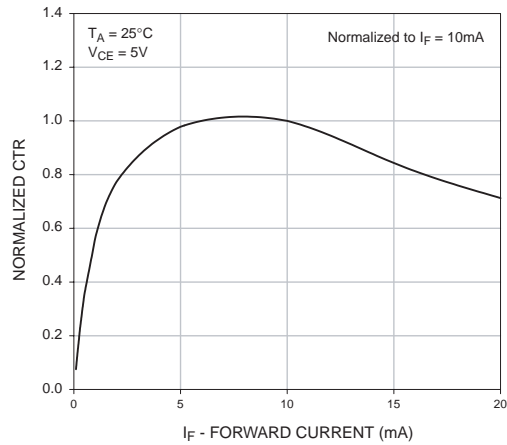

Fig. 3 Normalized CTR vs. Ambient Temperature

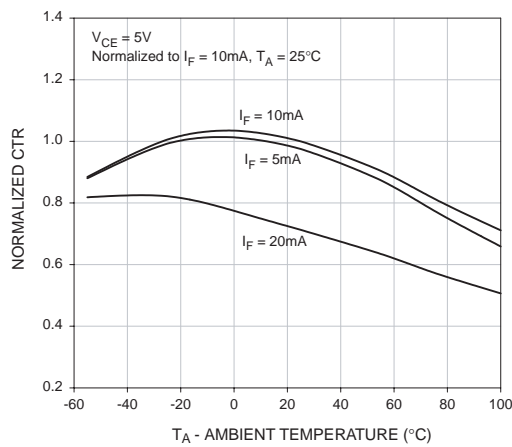

Fig. 4 CTR vs. RBE (Unsaturated)

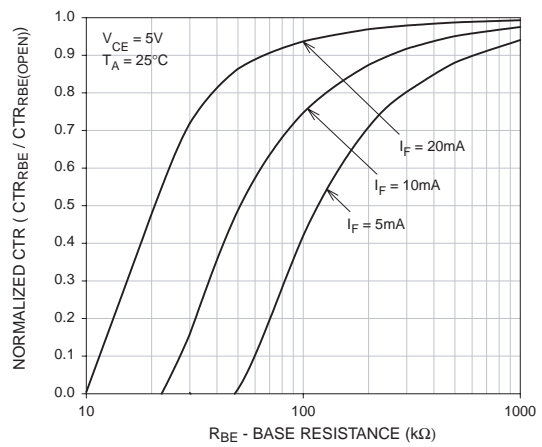

Fig. 5 CTR vs. RBE (Saturated)

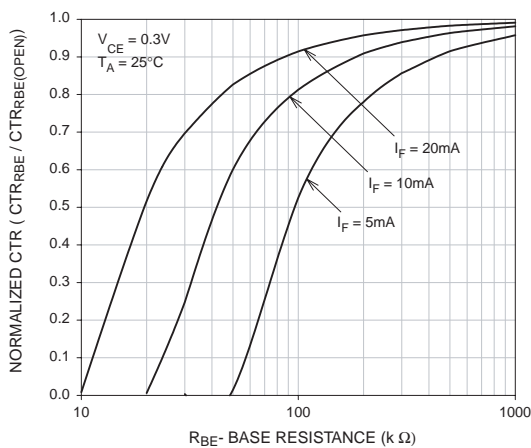
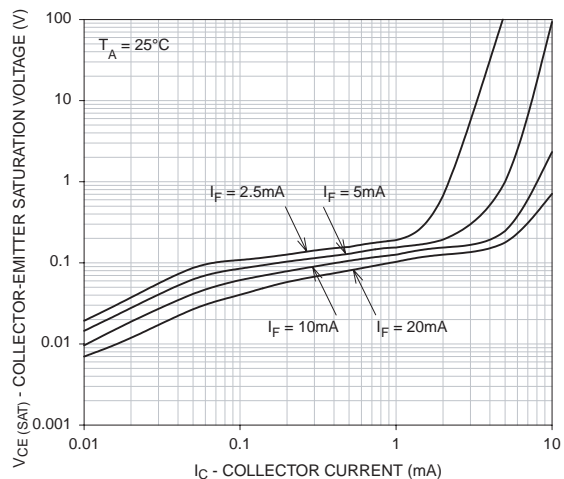

Fig. 6 Collector-Emitter Saturation Voltage vs. Collector Current



H11AA1-M

H11AA2-M

H11AA3-M

H11AA4-M

Fig. 7 Switching Speed vs. Load Resistor

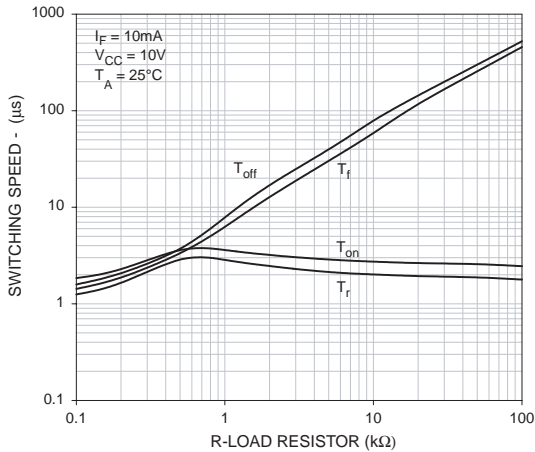

Fig. 8 Normalized t_{on} vs. R_{BE}

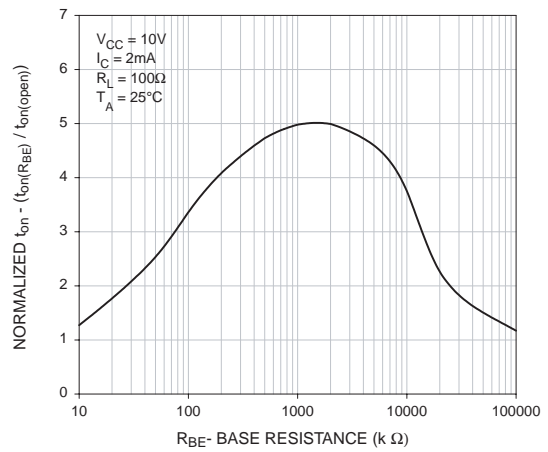

Fig. 9 Normalized t_{off} vs. R_{BE}

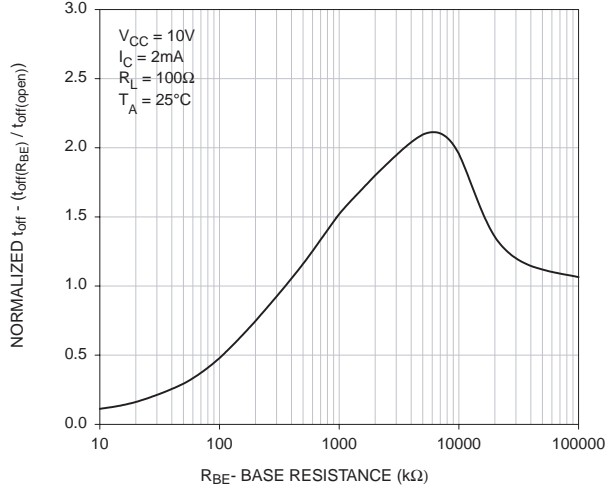

Fig. 10 Dark Current vs. Ambient Temperature

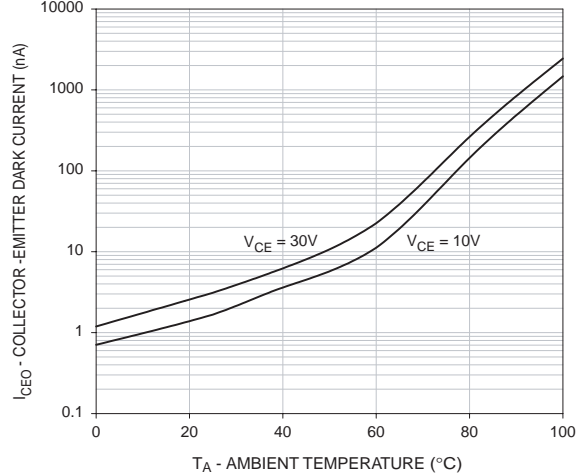
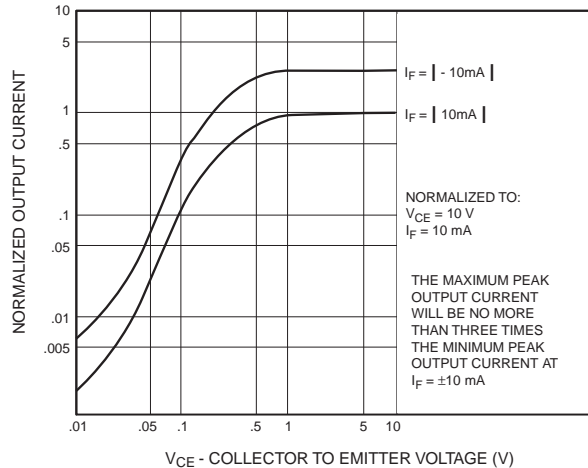

Fig. 11 Output Symmetry Characteristics



H11AA1-M

H11AA2-M

H11AA3-M

H11AA4-M

Package Dimensions (Through Hole)

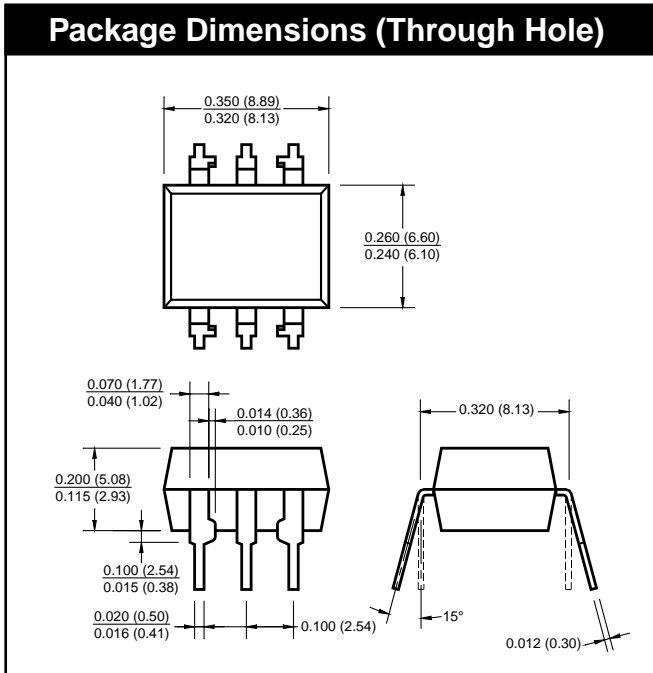

Package Dimensions (Surface Mount)

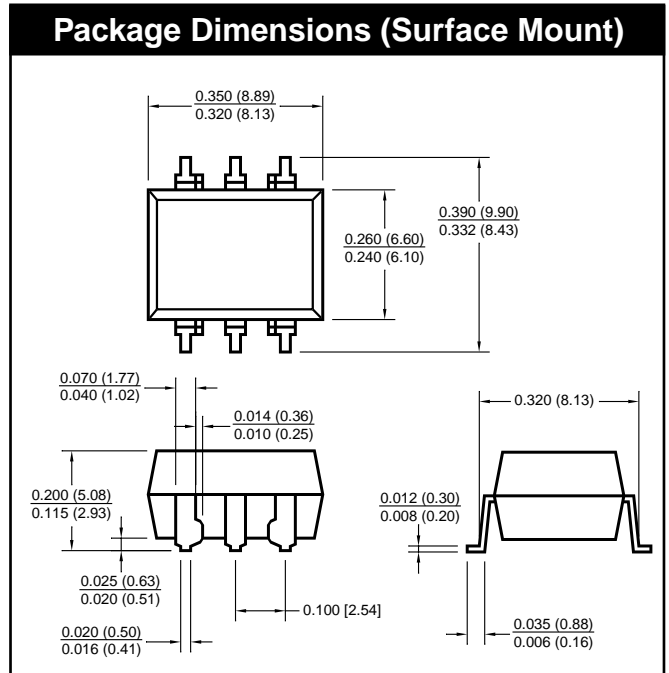

Package Dimensions (0.4" Lead Spacing)

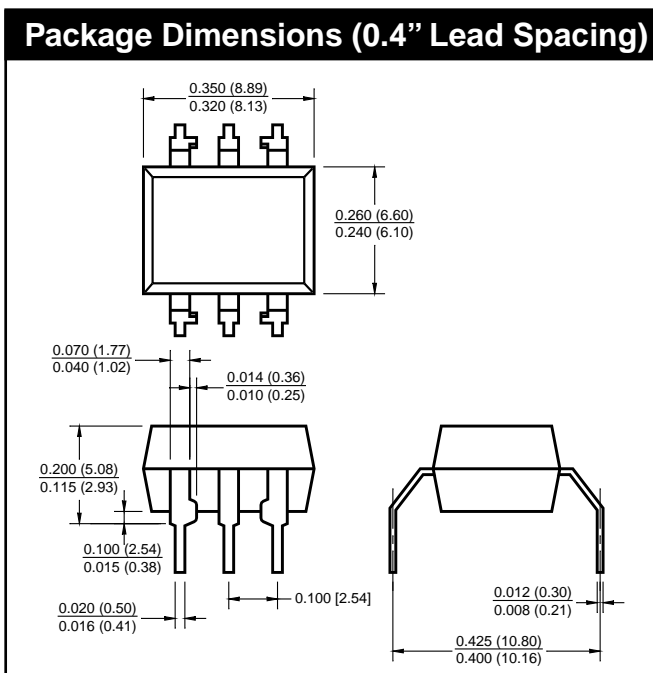

**Recommended Pad Layout for
Surface Mount Leadform**

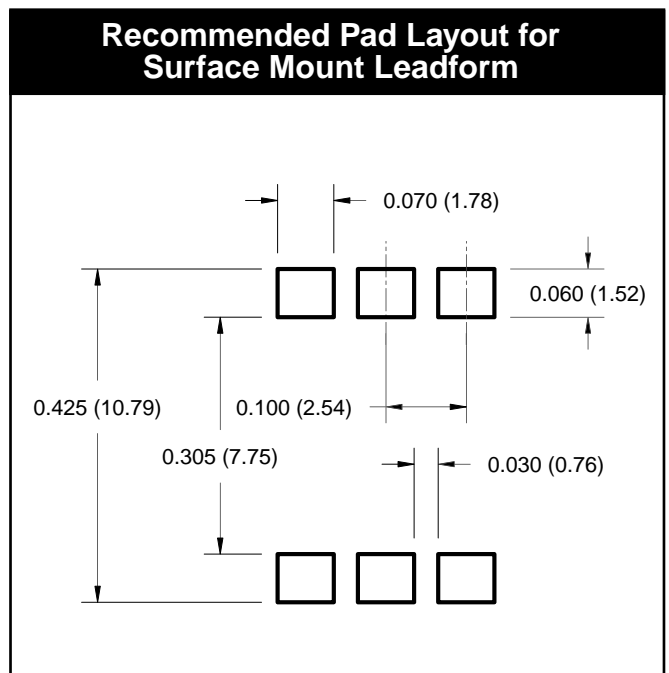

NOTE

All dimensions are in inches (millimeters)

H11AA1-M

H11AA2-M

H11AA3-M

H11AA4-M

ORDERING INFORMATION

Option/Order Entry Identifier	Description
S	Surface Mount Lead Bend
SR2	Surface Mount; Tape and Reel
T	0.4" Lead Spacing
V	VDE 0884
TV	VDE 0884, 0.4" Lead Spacing
SV	VDE 0884, Surface Mount
SR2V	VDE 0884, Surface Mount, Tape & Reel

MARKING INFORMATION

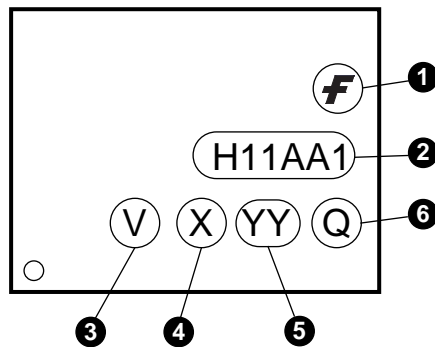

Definitions	
1	Fairchild logo
2	Device number
3	VDE mark (Note: Only appears on parts ordered with VDE option – See order entry table)
4	One digit year code, e.g., '3'
5	Two digit work week ranging from '01' to '53'
6	Assembly package code

*Note – Parts that do not have the 'V' option (see definition 3 above) that are marked with date code '325' or earlier are marked in portrait format.

H11AA1-M

H11AA2-M

H11AA3-M

H11AA4-M

Carrier Tape Specifications

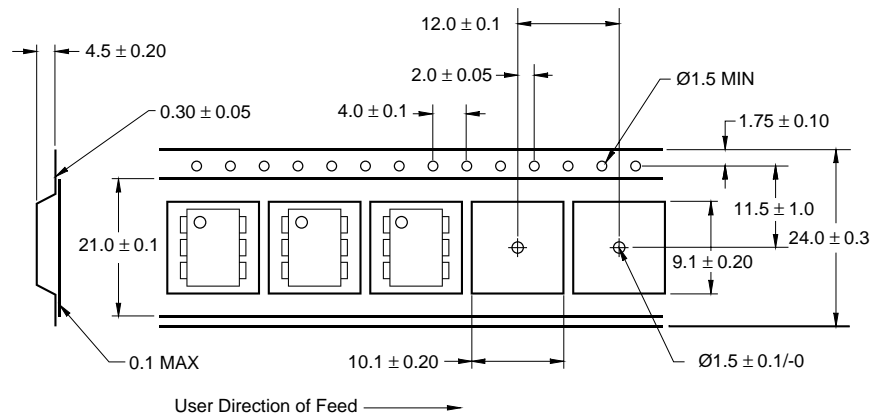

NOTE

All dimensions are in inches (millimeters)

Reflow Profile (White Package, -M Suffix)

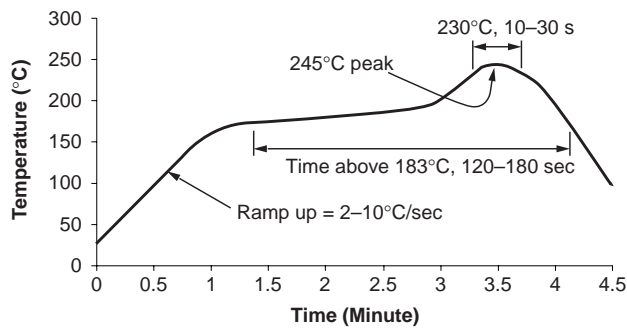

- Peak reflow temperature: 245°C (package surface temperature)
- Time of temperature higher than 183°C for 120–180 seconds
- One time soldering reflow is recommended

H11AA1-M

H11AA2-M

H11AA3-M

H11AA4-M

DISCLAIMER

FAIRCHILD SEMICONDUCTOR RESERVES THE RIGHT TO MAKE CHANGES WITHOUT FURTHER NOTICE TO ANY PRODUCTS HEREIN TO IMPROVE RELIABILITY, FUNCTION OR DESIGN. FAIRCHILD DOES NOT ASSUME ANY LIABILITY ARISING OUT OF THE APPLICATION OR USE OF ANY PRODUCT OR CIRCUIT DESCRIBED HEREIN; NEITHER DOES IT CONVEY ANY LICENSE UNDER ITS PATENT RIGHTS, NOR THE RIGHTS OF OTHERS.

LIFE SUPPORT POLICY

FAIRCHILD'S PRODUCTS ARE NOT AUTHORIZED FOR USE AS CRITICAL COMPONENTS IN LIFE SUPPORT DEVICES OR SYSTEMS WITHOUT THE EXPRESS WRITTEN APPROVAL OF THE PRESIDENT OF FAIRCHILD SEMICONDUCTOR CORPORATION. As used herein:

1. Life support devices or systems are devices or systems which, (a) are intended for surgical implant into the body, or (b) support or sustain life, and (c) whose failure to perform when properly used in accordance with instructions for use provided in the labeling, can be reasonably expected to result in a significant injury of the user.
2. A critical component in any component of a life support device or system whose failure to perform can be reasonably expected to cause the failure of the life support device or system, or to affect its safety or effectiveness.