

# SC Protector

Self Control Protector

## Innovative way of safety control for Li-ion rechargeable battery

www.datasheet4u.com

At any moment, SC Protector system monitors the voltage of Li-ion rechargeable battery and its heater fuses the fuse at the same instant when the system detects the overcharge. Usual protection element takes long time to work because it works due to temperature rise of battery cells.

The difference of SC Protector provides you high degree of freedom in the design of protection circuit.

### 1. Application

Typical application of protection for a Lithium ion rechargeable battery from overcharging is shown in the figure below.

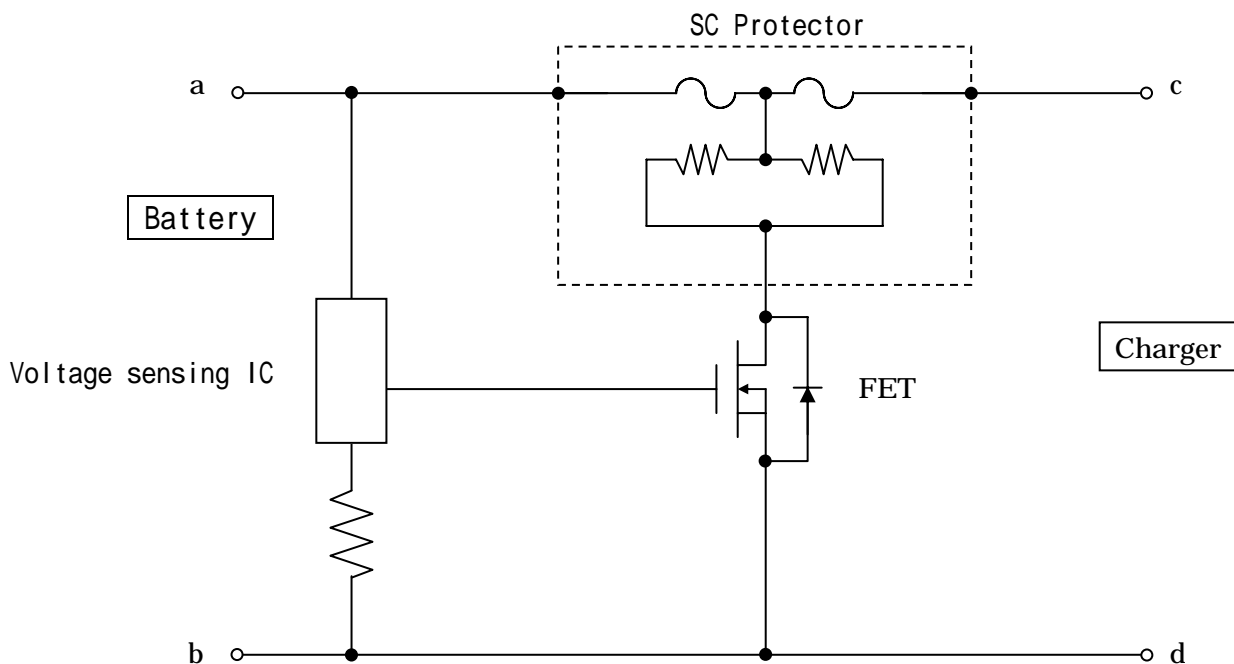

When the voltage between a and b exceeds the pre-set limit value, the output of the voltage detector IC becomes high and the FET is switched on. As a result, current flow through the heater of the protector, the fuses melt, and the battery stops to be charged any longer.

Since the two fuses cut-off the voltage supplies from the charger and the battery, the SC Protector stops to be heated immediately and thus, the safety control protection is provided against both excess voltage and excessive heating.

**Sony Chemicals Corporation**

**Electronic Devices Business Group**

1-11-2, Osaki, Shinagawa-ku, Tokyo, 141-0032 Japan

TEL+81-3-5435-3943 FAX+81-3-5435-3072

[http://www.scc.sony.co.jp/html\\_e/products/detail/prd04\\_f.html](http://www.scc.sony.co.jp/html_e/products/detail/prd04_f.html)

## 2. Characteristics of SC Protector

### 2.1. Necessity

#### 2.1.1. Reliability of the protection circuit

All Li-ion rechargeable battery packs are equipped with at least one protection circuit (ex.IC+FET).

In this case, when an IC or FET breaks, overcharge can't be controlled any more, and the temperature rise of the battery cell can invite very dangerous thermo-runaway leading to smoking or firing.

The trouble of the IC and FET actually occurs.

Therefore, double protection is needed to ensure the safety of Li-ion battery packs.

Basic circuit with troubles

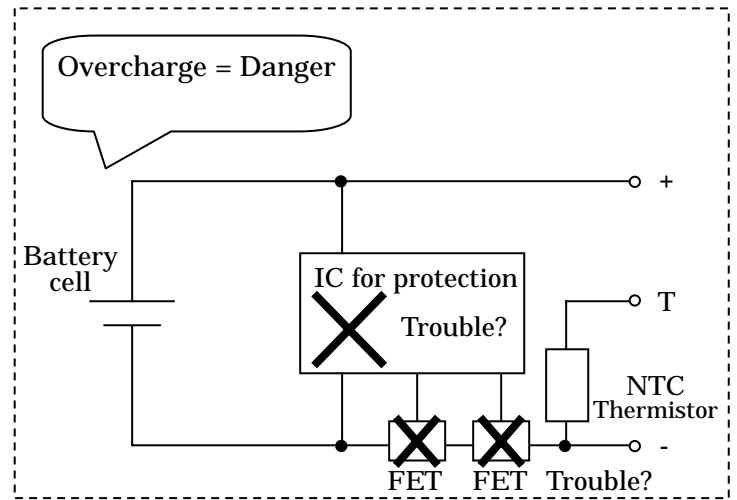

#### 2.1.2. The weak points of conventional double protection elements.

Protection devices such as temperature fuses and bimetals work by conducting the temperature rise in the battery to the inside of it via package or lead wire. Hence, they have a disadvantage that the response speed is slow, and the response speed fluctuates depending on the installation location of the device.

These elements obstruct a cost reduction since it is incompatible with the reflow soldering due to their structures, and must depend on manual soldering.

By using SC Protector, the battery cells won't become dangerous condition even if IC or FET breaks.

### 2.2. Characteristics

1) One device can protect against both overcharging and overcurrent.

2) Protection against overcharging is directly performed by the battery cell voltage, ensuring high accuracy and quick response, and the response speed does not fluctuate depending on the location and condition of installation.

3) At the same time of protection against overcharging, since it is constructed to send current to the heater via the fuse element, the fuse element forcibly fused by the heating of the heater and, upon the cutoff of charging circuit, the current to the heater automatically stops, and hence, SC Protector itself never overheated.

4) It is compatible with automatic mounting using general-purpose chip mounter, and at the same time, compatible with the reflow soldering, contributing to the reduction of parts mounting cost.

Double protection circuit using SC Protector

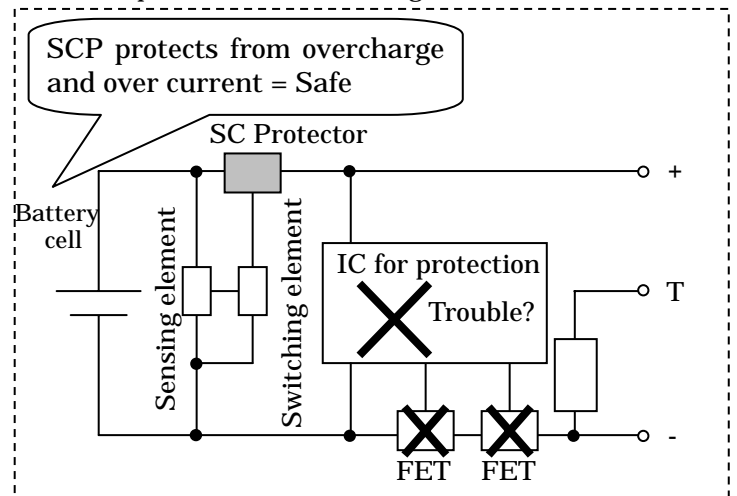

SC Protector has the strong points as shown above and it meets the safety requirement without spoiling the strong point of miniature of the Li-ion battery.

### 3. Specification

#### 3.1. General

	SC Protector
Environmental compliance	Compliance with RoHS and SS-00259
Qualification	UL248-14 (File No. E167588) , TUV (Certificate No. J9650637)
Rated voltage (*)	35VDC
Rated breaking capacity	50A
Re-flow temp. (MAX)	260deg.C

(\*) is the maximum voltage can be cut off by fuse. It is not the operational voltage of the heater.

#### 3.2. SFH-12A series

	For 1 cell in series SFH-0412A	For 2-3 cells in series SFH-1212A	For 4 cells in series SFH-1412A
Rated current	12A		
Size	5.4x3.2x1.35mm		
Electrode	Ag-Pt		
Fuse resistance (Typical)	2 - 4 mohms		
Operating electric power	6.5 - 35W	6 - 35W	
Operating voltage	4.0 - 7.0V	7.4 - 13.8V	10.5 - 19.6V
Heater resistance	1.4 - 2.4ohms	5.5 - 9.1ohms	11.0 - 18.4ohms
Marking	<div style="border: 1px solid black; padding: 2px; display: inline-block;">           12A H1            SC SF         </div>	<div style="border: 1px solid black; padding: 2px; display: inline-block;">           12A H3            SC SF         </div>	<div style="border: 1px solid black; padding: 2px; display: inline-block;">           12A H4            SC SF         </div>

#### 3.3. SFH-15A series

	For 1 cell in series SFH-0415A	For 2-3 cells in series SFH-1215A	For 4 cells in series SFH-1415A
Rated current	15A		
Size	5.4x3.2x1.35mm		
Electrode	Au plated Ag-Pt		
Fuse resistance (Typical)	1 - 3 mohms		
Operating electric power	7.0 - 30W	6.5 - 35W	
Operating voltage	4.0 - 6.4V	7.4 - 13.8V	10.5 - 19.6V
Heater resistance	1.4 - 2.2ohms	5.5 - 8.3ohms	11.0 - 17.0ohms
Marking	<div style="border: 1px solid black; padding: 2px; display: inline-block;">           15A H1            SC SF         </div>	<div style="border: 1px solid black; padding: 2px; display: inline-block;">           15A H3            SC SF         </div>	<div style="border: 1px solid black; padding: 2px; display: inline-block;">           15A H4            SC SF         </div>

#### [NOTICE]

SFG, SFD, and SFC series are going to be discontinued products.

The schedule after it shall be done is as below.

March 31, 2006. Discontinue production. - We will stop receiving a usual order.

April 1, 2006. Support period start. - We could only receive 48Kpcs or more at one time.

- Delivery time would be about 3 month.

- Price might become higher than before.

March 31, 2007. Support period end. We will stop producing completely.

## 4. Basis of selection to change to SFH

\*If you are using SCP that is not SFH, please change to SFH according to the following table as soon as possible.

Number of cells in series				Nominal Rated current	Current-carrying capacity <sup>(*1)</sup>			Current Rush Withstand	Soldering	Compliance with RoHS
1cell	2cell	3cell	4cell		25C	40C	60C			
<b>SFH-0412A</b>	<b>SFH-1212A</b>		<b>SFH-1412A</b>	12A	13.5A	12.0A	10.0A	100A-10ms ( 2 )	Reflow Max 260deg.C	
SFH-0415A	SFH-1215A		SFH-1415A	15A	17.0A	15.0A	12.5A	100A-10ms ( 3 )		
<del>SFG-0412A</del>		<del>SFG-1212A</del>	<del>SFG-1412A</del>	-						
<del>SFD-045A</del>		<del>SFD-125A</del>	<del>SFD-165A</del>							
<del>SFD-047A</del>		<del>SFD-127A</del>	<del>SFD-147B</del>							

Common model of thermal fuse with heater	12A	9A at 40deg.C (Fusing-off by 13A at 40deg.C)	Soldering iron Spot reflow
--	-----	---	-------------------------------

(\*1) It is the typical value that is calculated from 100 deg.C, the temperature that we confirmed the reliability with our company's standard PCB (0.6t Glass Epoxy single-sided copper-clad laminates). It is influenced by thermal capacity of PCB and so we recommend checking it with your PCB.

- 25deg.C, 40deg.C and 60deg.C are ambient temperature.
- The temperature that we confirmed the reliability is not a critical condition. SCP fusing-off temperature is 200deg.C or more.
- Current-carrying capacity is measured in thermal equilibrium condition. Therefore, if Current-carrying time is short, Current-carrying capacity will increase.

(\*2) It is the test condition (10ms-On, 9990ms-Off, 500cycle) that we confirmed the reliability. But it is not necessarily a critical condition for SCP.

(\*3) It is the test condition (10ms-On, 9990ms-Off, 1000cycle) that we confirmed the reliability. But it is not necessarily a critical condition for SCP.

## 5. Voltage operation

### 5.1. Operating electric power and Operating voltage

1) Operating electric power range: Electricity Power applied to heater

2) Operating voltage range: Values are calculated from operating electric power range and heater resistance. Protector operation is normal under voltage applied to heaters in these ranges. Operating voltage range is adjustable by regulating heater resistance.

www.datasheet4u.com

$$\text{(Operating voltage[V] = } \frac{\text{Operating electric power [W]} \times \text{Heater resistance[ } \Omega \text{]}}{\text{)}})$$

### 5.2. Voltage operation test method

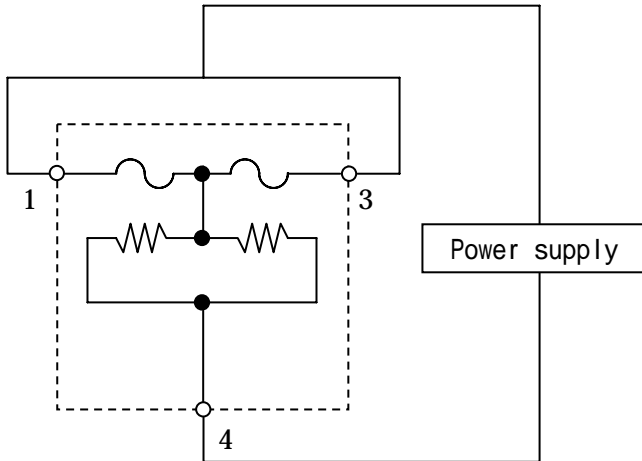

1) Connect SC Protector with a constant power supply.

2) Apply a current to the heater.

3) Measure the time the fuses take to melt.

### 5.3. Operation time by the heater (Electricity vs. clearing time at 25 deg.C)

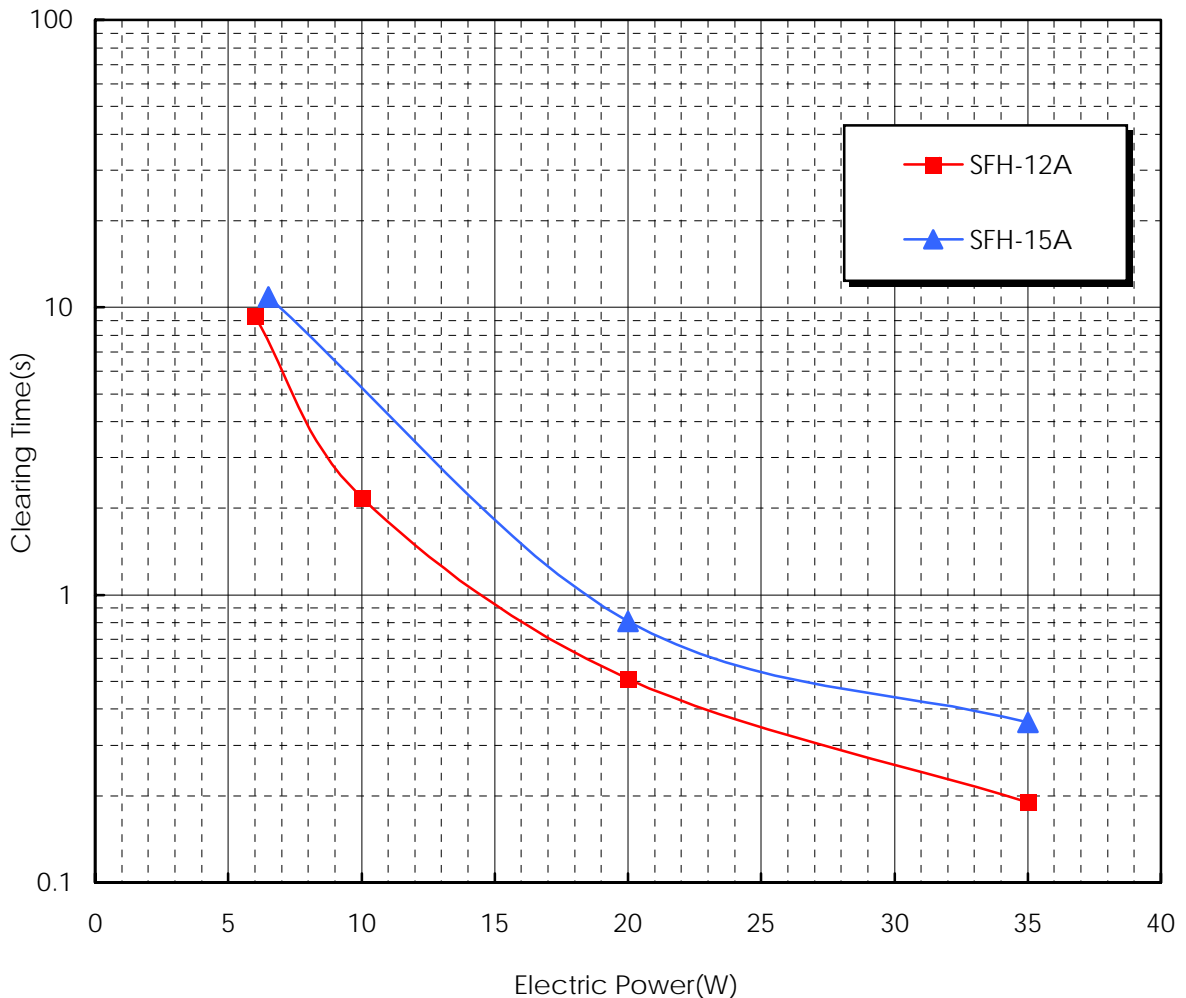

5.4. Operation time by the heater (Voltage vs. clearing time at 25 deg.C)

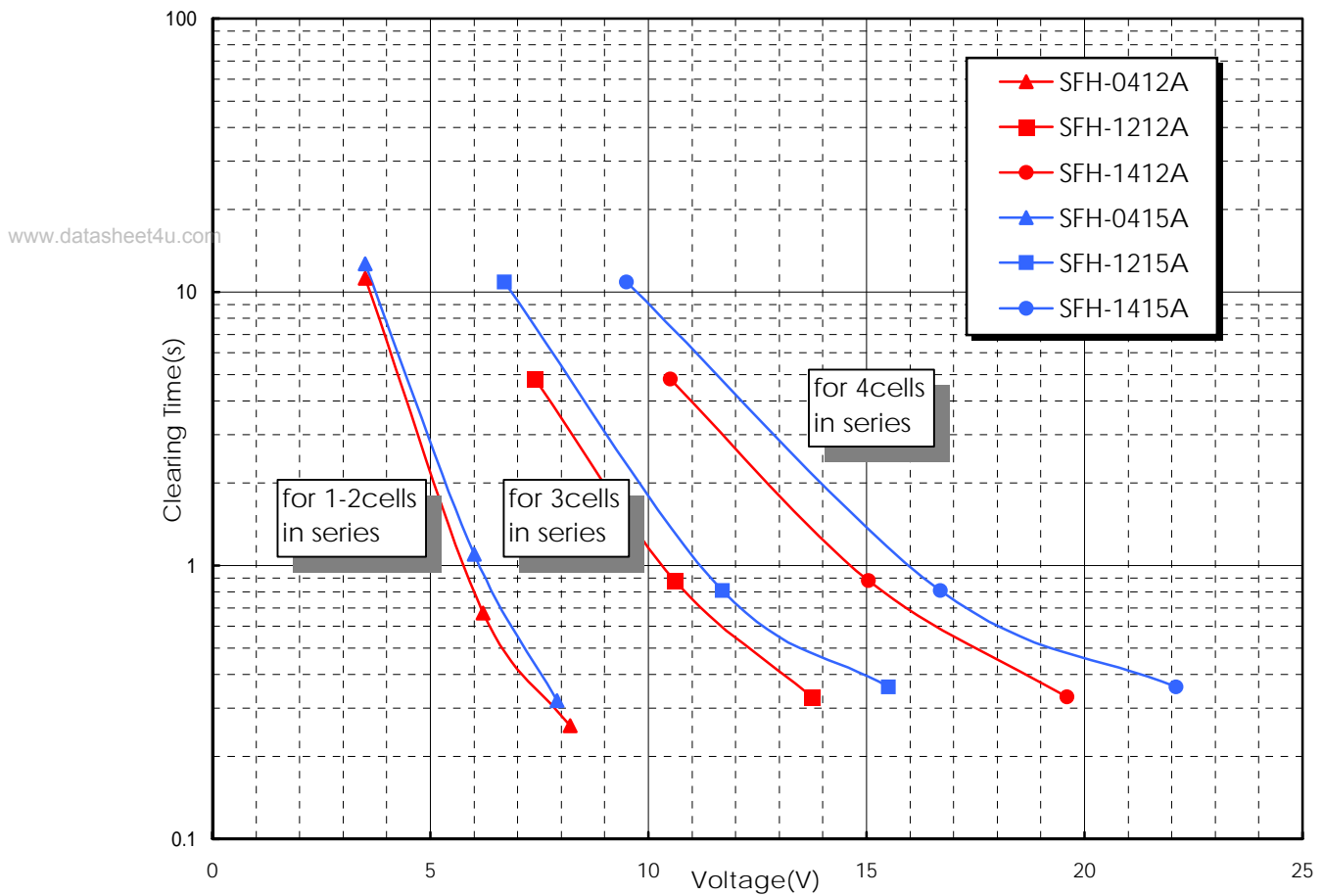

5.5. Operation time by the heater (Ambient temperature vs. clearing time)

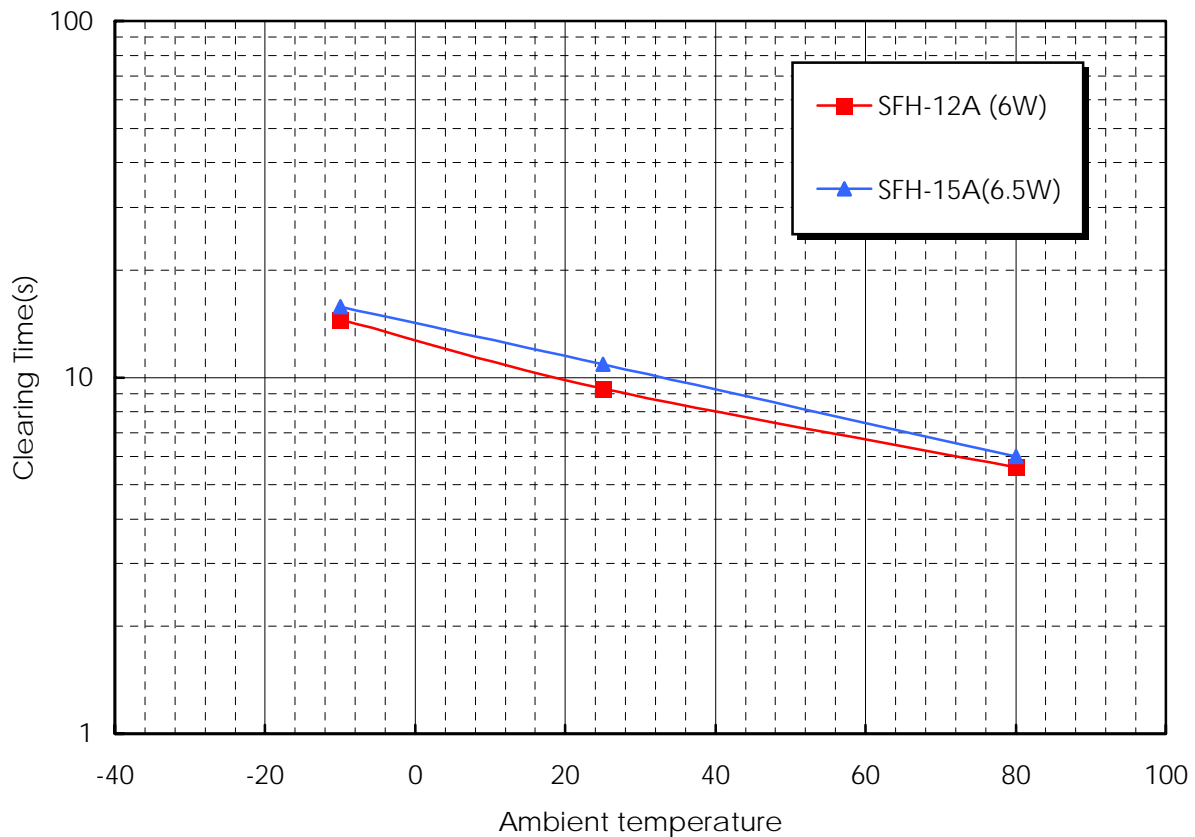

6. Current interrupting time (at 25 deg.C)

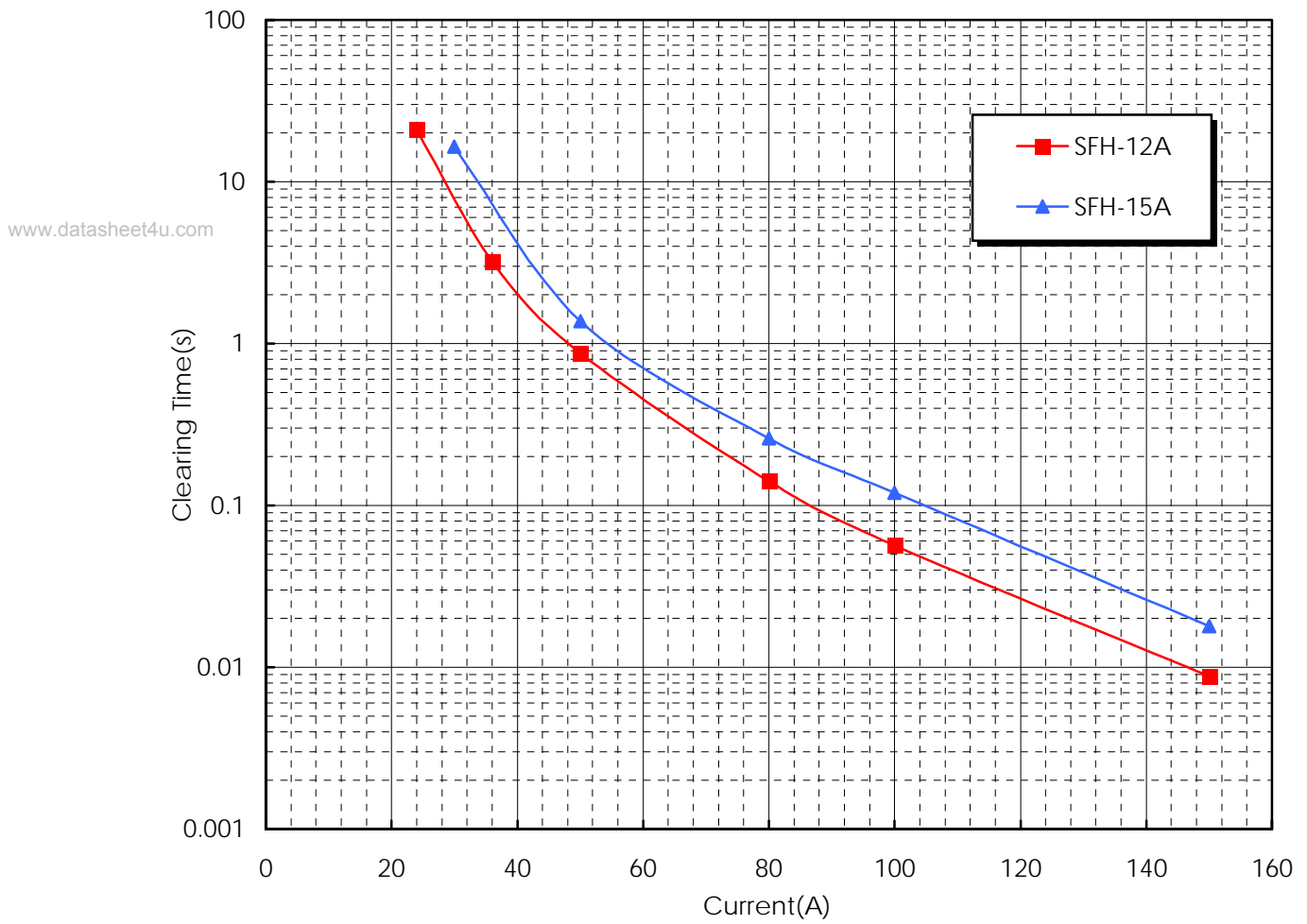

6.1. Current interrupting time (Ambient temperature vs. Clearing time by Rated Current \* 2)

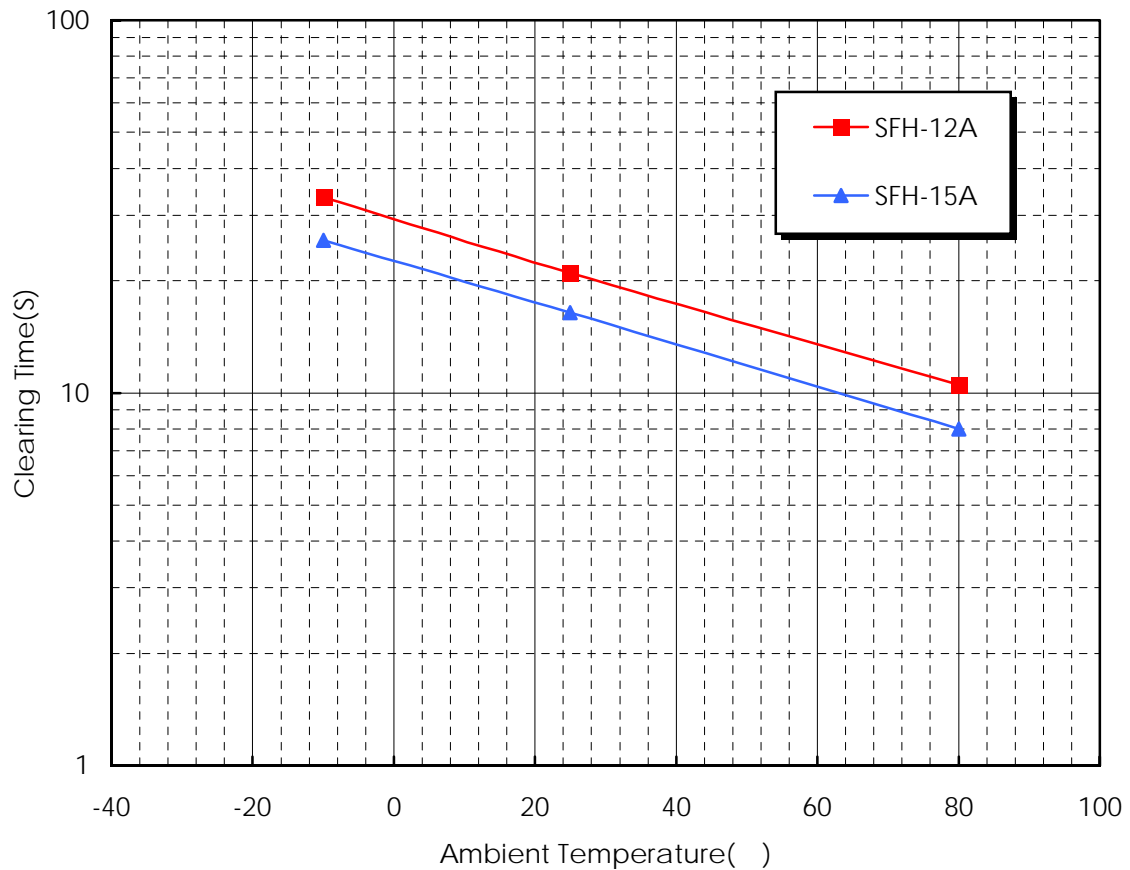

## 7. Relations between the fusion state and the operation mode

“The operation mode” can be estimated by the fusion state of the fuse element.

### 7.1. Heater operation

www.datasheet4u.com

In the case of over-voltage, “Both two sides of the middle electrode” are fused by the heater operation. Because the fuses are heated until the charge to the heater is stopped.

Only one side may be cut when the protection circuit is designed so that charging to the heater stops by cutting of one side of the middle electrode.

For the heater operation, it is characterized as “Fuses like flow into the middle electrode.”

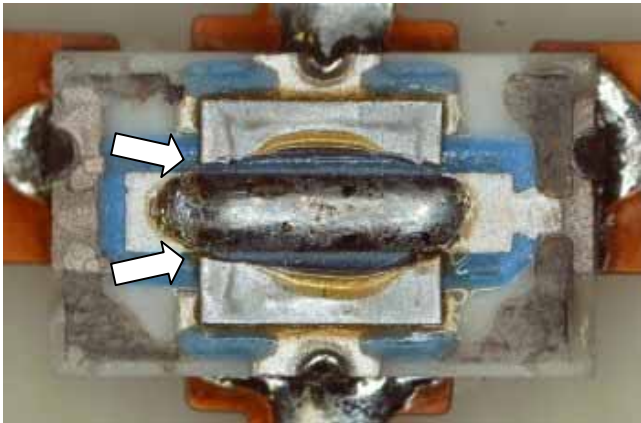

<Features of the heater operation>

- \* Fuses like flow into the middle electrode
- \* Both two side (or one side) is fused

### 7.2. Current operation

In the case of over-current operation, basically, “only one position of the fuse is cut” because it is the same operation mode as the conventional electric current fuse. When the current exceeds 50A, two positions are cut occasionally.

For the current operation, it is characterized as “The cutting position isn't fixed”, “It cuts like bursting”.

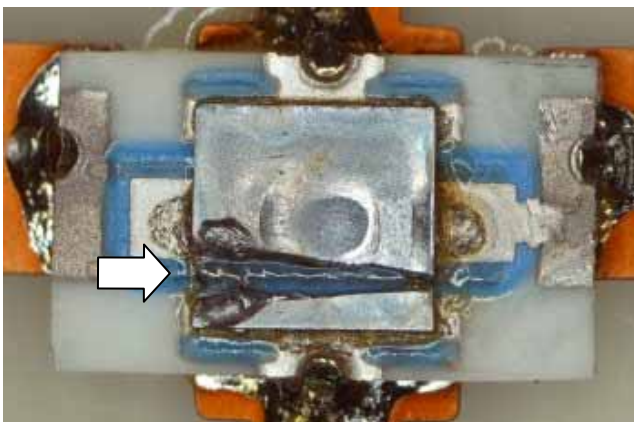

<Features of the current operation>

- \* Cutting position isn't fixed
- \* It cuts like bursting
- \* One position is cut basically (Over 50A, two positions are cut occasionally)



8. External view & Equivalent circuit

\*SFH series (Rated current 12-15A)

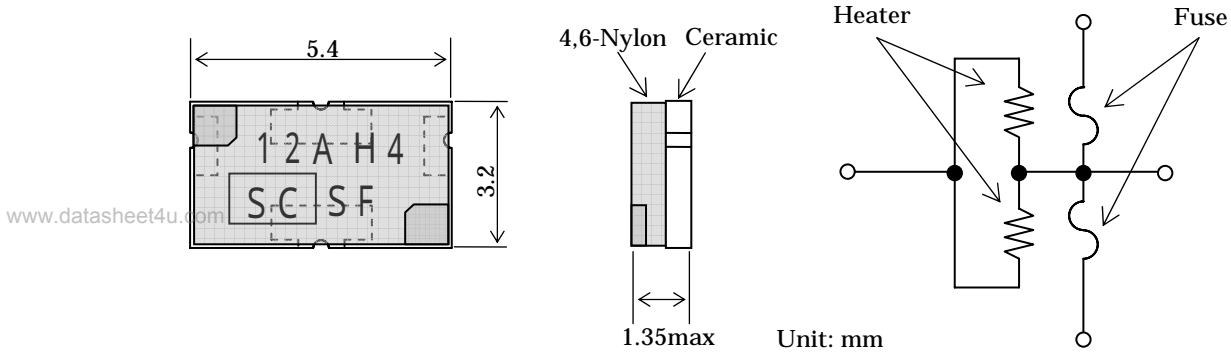

9. Terminal Size (Unit: mm. Not in scale.)

\*SFH series (Rated current 12-15A)

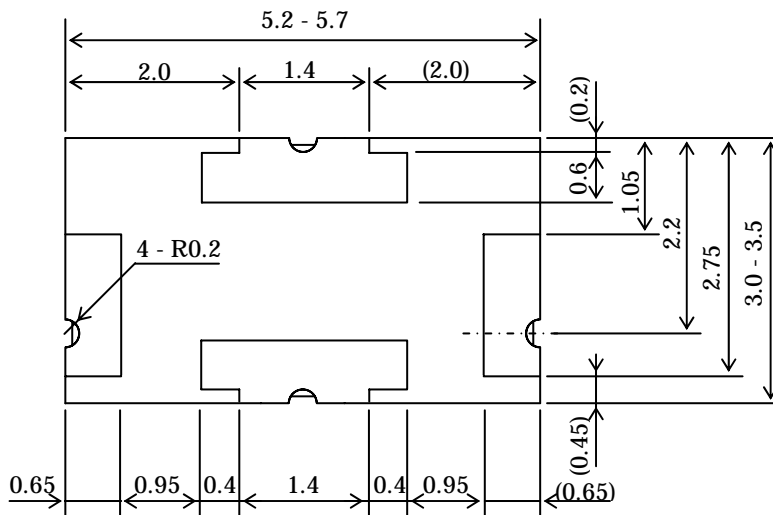

10. Temperature profile of reflow soldering

The temperature shown below is the temperature of the electrode portion of SC Protector.

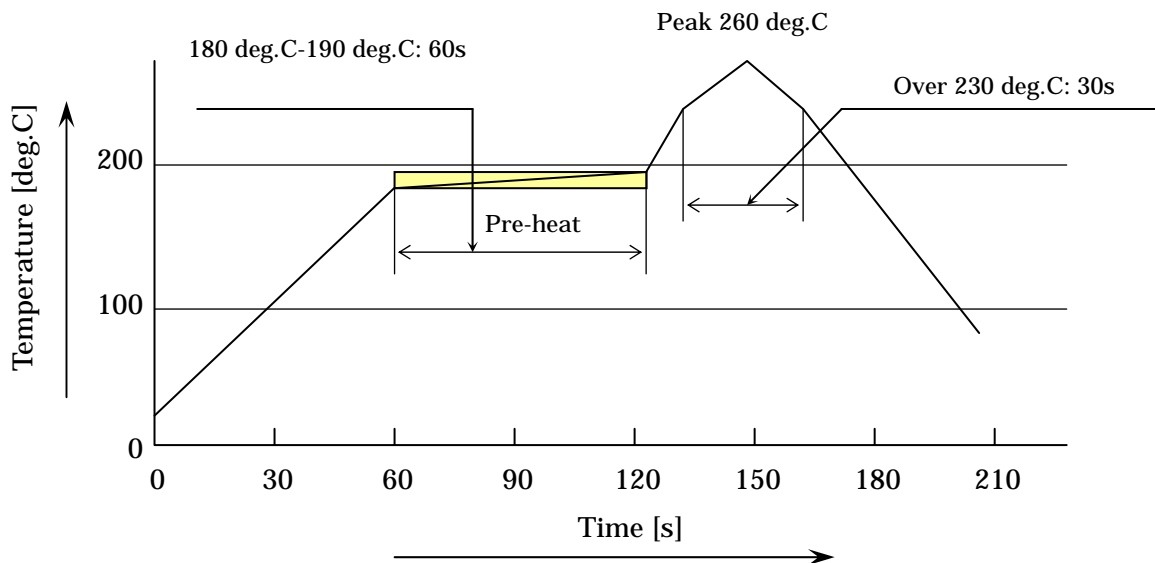

## 11. Others

11.1. Please confirm the latest product information before a design.

You can confirm the latest information on SC protector in the following homepage.

[http://www.scc.sony.co.jp/html\\_e/products/detail/prd04\\_f.html](http://www.scc.sony.co.jp/html_e/products/detail/prd04_f.html)

11.2. SC-Protector complies with environmental regulation.

1) SC-Protector complies with RoHS.

2) SC-Protector complies with SS-00259, Sony environmental management standard.

11.3. Catalog data is the typical value.

1) Catalog data is not a guaranteed value.

2) Catalog data is measured with our company's standard PCB (0.6t Glass Epoxy single-sided copper-clad laminates). The characteristics are influenced by thermal capacity of PCB. Generally, when thermal capacity of PCB increases, Current-carrying capacity will increase and Clearing-time will be long.

11.4. Please select the product on the basis of [Current-carrying capacity] and [Heater operation characteristics].

1) Nominal rated current is provided on the basis of UL standard (The maximum temperature rise on body or contact that is passed the current shall not exceed 70 deg.C) and so it is not Current-carrying capacity. Therefore, please select a product on the basis of Current-carrying capacity instead of Nominal rated current.

2) [Current-carrying capacity] and [Heater operation characteristics] are influenced by thermal capacity of PCB and so on. Therefore we recommend checking it on your PCB.

3) We accept the test (Current-carrying capacity and Clearing-characteristics and so on) with your PCB. Please request to us unreservedly.

11.5. Current-carrying capacity

1) Current-carrying capacity is the current-carrying value that SCP reaches temperature that we confirmed the reliability in our company.

2) The temperature that we confirmed the reliability is 100 deg.C. But it is not a critical condition for SCP. For example, if SCP temperature exceeds it, SCP is not immediately fusing-off like a common thermal fuse. SCP fusing-off temperature is 200 deg.C or more and so it has much more capability for the temperature rise.

3) Current-carrying capacity is measured in thermal equilibrium condition so that if Current-carrying time is short, Current-carrying capacity will increase.

11.6. Precautions regarding handling

1) Make sure that the terminals of this product are connected on the lands of the circuit board, and that the resistance between terminal1-4 and 3-4 are rated heater resistance.

2) Ultrasonic cleansing or immersion cleansing must not be done for SCP. When cleansing is done, flux in element flows, and the specification will not be satisfied. These products after cleansing will be not guaranteed.

---

---

## Sony Chemicals Corporation

### Electronic Devices Business Group

1-11-2, Osaki, Shinagawa-ku, Tokyo, 141-0032 Japan

TEL+81-3-5435-3943 FAX+81-3-5435-3072

[http://www.scc.sony.co.jp/html\\_e/products/detail/prd04\\_f.html](http://www.scc.sony.co.jp/html_e/products/detail/prd04_f.html)