

# Microcontroller for television and video (MTV)

## 83C053/83C054/87C054

### DESCRIPTION

The Microcontroller for Television and Video (MTV) applications is a derivative of Philips' industry-standard 80C51 microcontroller that is intended for use as the central control mechanism in a television receiver or tuner. Providing tuner functions and an On Screen Display facility, it represents a next-generation replacement for the currently available parts.

The MTV is available in either an 8K masked ROM, 16K masked ROM, or 16K One Time Programmable (OTP) EPROM version. The only difference between these versions is the size or type of program memory.

### FEATURES

- 8192 × 8 masked ROM (83C053), 16384 × 8 masked ROM (83C054), or 16384 × 8 OTP EPROM (87C054)
- 192 × 8 RAM
- On Screen Display (OSD) Controller
- Three digital video outputs
- Multiplexer/mixer and background intensity controls
- Flexible formatting with OSD New Line Option
- 128 × 10 display RAM

- 60 × 18 × 14 character generator ROM
- Eight text-shadowing modes
- Text color selectable per character
- Background color selectable per word
- Background color vs. video selectable per character
- Eight 6-bit pulse width modulators for analog voltage integration
- One 14-bit PWM for high-precision voltage integration
- D/A converter and comparator with three-input multiplexer
- Nine dedicated I/Os plus 28 port bits
- 15 port bits have alternate uses
- Four high-current open-drain port outputs
- 12 high-voltage (+12V) open drain outputs
- Programmable video input and output polarities
- 80C51 instruction set
- No external memory capability
- 42-pin shrink Dual In-Line Package (0.07-inch center pins)
- High-speed CMOS technology
- 5V ± 10% operation

### PIN CONFIGURATION

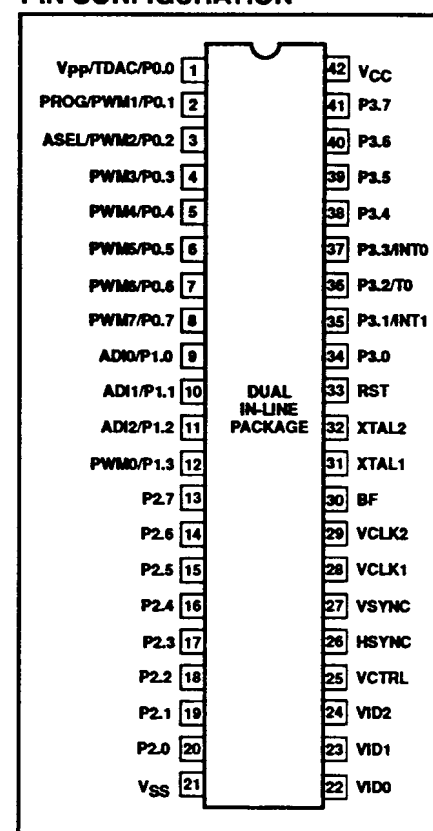

### ORDERING INFORMATION

ROM	EPROM	TEMPERATURE RANGE °C AND PACKAGE	FREQUENCY MHz	DRAWING NUMBER
P83C053BBP NB		0 to +70, 42-Pin Plastic Dual In-Line Package	3.5 to 12	1680
P83C054BBP NB	P87C054BBP NB	0 to +70, 42-Pin Plastic Dual In-Line Package	3.5 to 12	1680

# Microcontroller for television and video (MTV)

## 83C053/83C054/87C054

### BLOCK DIAGRAM

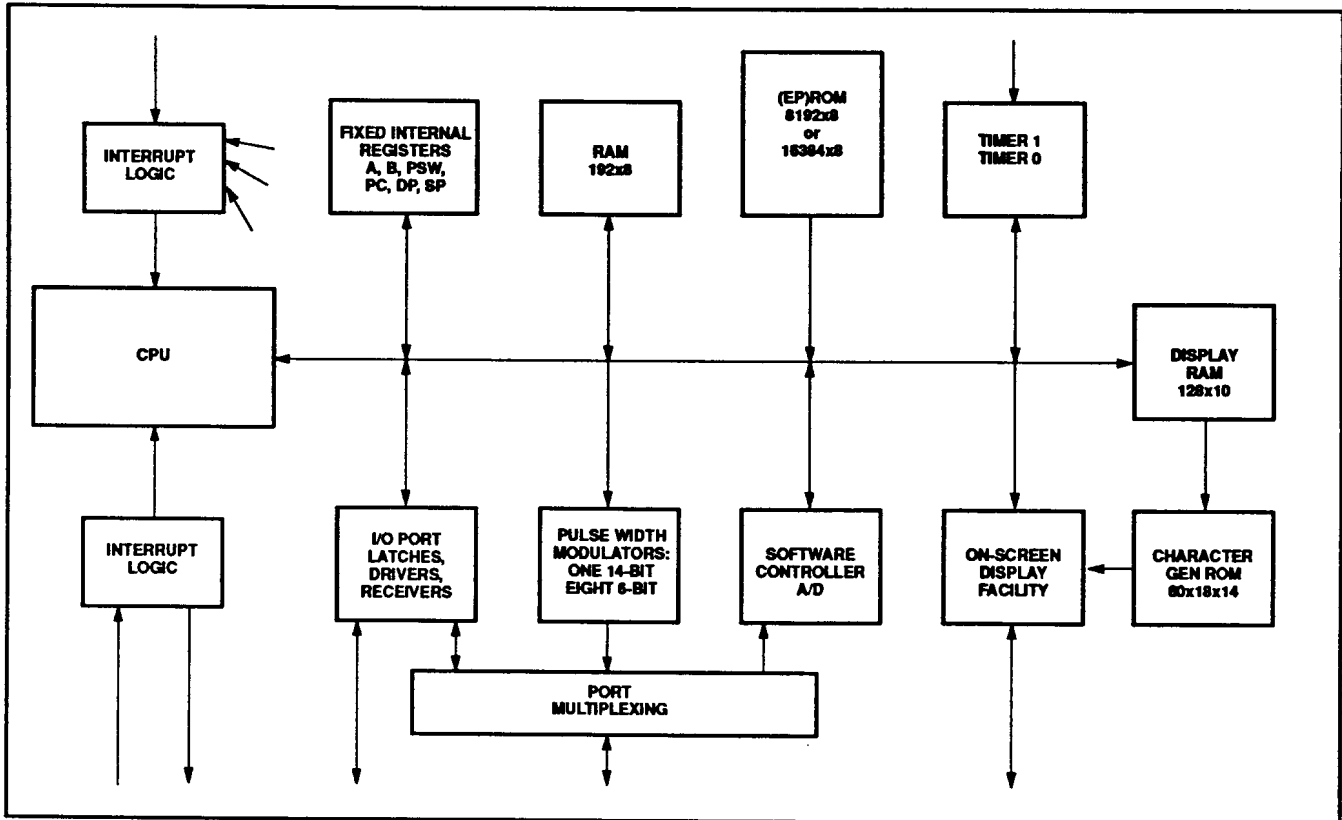

www.DataSheet4U.com

# Microcontroller for television and video (MTV)

83C053/83C054/87C054

## PIN DESCRIPTIONS

MNEMONIC	PIN NO. DIP	TYPE	NAME AND FUNCTION
VCLK1	28	I	<b>Video Clock 1:</b> Input for the horizontal timing reference for the On Screen Display facility. VCLK1 and VCLK2 are intended to be used with an external LC circuit to provide an on-chip oscillator. The period of the video clock is determined such that the width of a pixel in the On Screen Display is equal to the inter-line separation of the raster.
VCLK2	29	O	<b>Video Clock 2:</b> Output from the on-chip video oscillator.
HSYNC	26	I	<b>Horizontal Sync:</b> A dedicated input for a TTL-level version of the horizontal sync pulse. The polarity of this pulse is programmable; its trailing edge is used by the On Screen Display facility as the reference for horizontal positioning.
VSYNC	27	I	<b>Vertical Sync:</b> A dedicated input for a TTL-level version of the vertical sync pulse. The polarity of this pulse is programmable, and either edge can serve as the reference for vertical timing.
VID2:0	22–24	O	<b>Digital Video bus:</b> Three totem pole outputs comprising digital RGB (or other color encoding) from the On Screen Display facility. The polarity of these outputs is controlled by a programmable register bit.
VCTRL	25	O	<b>Video Control:</b> A totem-pole output indicating whether the On Screen Display facility is currently presenting active video on the VID2:0 outputs. This signal should be used to control an external multiplexer (mixer) between normal video and the video derived from VID2:0. The polarity of this outputs is controlled by a programmable register bit.
BF	30	O	<b>Background/Foreground:</b> A totem-pole output which, when VCTRL is active, indicates whether the current video data represents a foreground (low) or background (high) dot in a character. This signal can be used to reduce the intensity of the background color and thus emphasize the text. If a 40-pin version of this part is ever produced, BF will not be pinned out.
P0.0-P0.7	1–8	I/O	<b>Port 0:</b> An 8-bit open-drain bidirectional port. Port 0 pins that have ones written to them float, and in that state can be used as high-impedance inputs. The port 0 pins can also serve as outputs from the high-precision Pulse Width Modulator (TDAC) and seven of the eight lower-precision Pulse Width Modulator functions. For each PWM block, a register bit controls whether the corresponding pin is controlled by the block or by port 0; port 0 controls the pin immediately after a Reset. Regardless of how each pin is controlled, it can be externally pulled up as high as $+12V \pm 5\%$ , and the state of the pin can be read from the Port 0 register by the program. <b>V<sub>PP</sub> (P0.0)</b> – This pin receives the 12V programming supply voltage during EPROM programming. <b>PROG (P0.1)</b> – This pin receives the programming pulses during EPROM programming. <b>ASEL (P0.2)</b> – Input which indicates which bits of the EPROM address are applied to port 2. <b>TDAC (P0.0)</b> – This is the output for the 14-bit high-precision PWM. <b>PWM1–7 (P0.1–P0.7)</b> – Outputs for the 6-bit PWMs 1 through 7.
P1.0-P1.3	9–12	I/O	<b>Port 1:</b> A 4-bit open-drain bidirection port. Port 1 pins that have ones written to them float, and in that state can be used as high-impedance inputs. P1.3 can also serve as the eighth lower-precision Pulse Width Modulator output (PWM0), and can be externally pulled up as high as $+12V \pm 5\%$ . P1.2:0 have optional alternate use as AD12:0, inputs to the Software A/D conversion facility. If a 40-pin version of this part is ever produced, P1.3/PWM0 will not be pinned out. Any of the port 1 pins are driven low if the corresponding port register bit is written as 0, or, for P1.3 only, if the TDAC module presents a 0. The state of the pin can always be read from the port register by the program. <b>AD10–2 (P1.0–P1.2)</b> – Inputs for the software A/D facility. <b>PWM0 (P1.3)</b> – Output for the PWM0 6-bit PWM.
P2.0-P2.7	20–13	I/O	<b>Port 2:</b> An 8-bit open-drain bidirectional port. Port 2 pins that have ones written to them float, and in that state can be used as high-impedance inputs. P2.3:0 have high current capability (10 mA at 0.5V) for LEDs. Any of the port 2 pins are driven low if the port register bit is written as 0. The state of the pin can always be read from the port register by the program.
P3.0-P3.7	34–42	I/O	<b>Port 3:</b> An 8-bit open-drain bidirectional port. Port 3 pins that have ones written to them float, and in that state can be used as high-impedance inputs. P3.0, P3.4, and P3.7 can be externally pulled up as high as $+12V \pm 5\%$ , while P3.5 and P3.6 have 10mA drive capability. Some of the port 3 pins can also serve alternate functions, as follows: <b>INT1 (P3.1)</b> – External Interrupt 1. <b>T0 (P3.2)</b> – Timer 0 external input. <b>INT0 (P3.3)</b> – External Interrupt 0.

# Microcontroller for television and video (MTV)

83C053/83C054/87C054

## PIN DESCRIPTIONS (Continued)

MNEMONIC	PIN NO. DIP	TYPE	NAME AND FUNCTION
RST	33	I	<b>Reset:</b> If this pin is high for two machine cycles (24 oscillator periods) while the oscillator is running, the MTV is reset. Also, this pin is used as a serial input to enter a test or EPROM programming mode, as on the 87C751.
XTAL1	31	I	<b>Crystal 1:</b> Input to the inverting oscillator amplifier and clock generator circuit that provides the timing reference for all MTV logic other than the OSD facility. XTAL1 and XTAL2 can be used with a quartz crystal or ceramic resonator to provide an on-chip oscillator. Alternatively, XTAL1 can be connected to an external clock, and XTAL2 left unconnected.
XTAL2	32	O	<b>Crystal 2:</b> Output from the inverting oscillator amplifier.
V <sub>CC</sub>		I	<b>Power Supply:</b> This is the power supply for normal and power-down modes.
V <sub>SS</sub>		I	<b>Ground:</b> 0V reference.

## ROM CODE SUBMISSION

When submitting a ROM code for the 83C053 or 83C054, the following must be specified:

1. The 8k byte (83C053), or 16k byte (83C054) user ROM program.
2. The OSD ROM space.

This information can be submitted in an 87C054, or in two EPROMs (2764), or electronically on the ROM Code Bulletin Board (see your local sales office for the number).

## ROM CODE SUBMITTAL REQUIREMENTS

ADDRESS	CONTENT	COMMENT
0000H to 1FFFH (83C053) 000H to 3FFFH (83C054)	DATA	User ROM data
C000H to CFFFH	OSD	On-Screen Display character table

## PROGRAMMING THE OSD EPROM

### Overview

The OSD EPROM space starts at location C000H and ends at location CFFFH. However, not all locations within this space are used, due to the addressing scheme of the OSD.

The start location of the next character can be calculated by adding 40H to the start location of the previous character. For example, character #1 starts at C000H; then characters 2, 3, and 4 start at C040H, C080H, and C0C0H, respectively.

### Character Description

Each character is 14 bits wide by 18 lines high.

A character is split about a vertical axis into two sections, UPPER and LOWER. Each section contains 7 bits of the character, such that the LOWER section contains 1–7 and the UPPER section contains bits 8–14.

**NOTE:** During programming and verification, each section is programmed using bytes of DATA. The MSB of the DATA is not used; however, the MSB location physically exists, and so will program and verify.

The LOWER section of the character is programmed when the LSB of the program address equals 0, and the UPPER section when the LSB equals 1.

### Character Programming

An example of an OSD character bit map, and the program DATA to obtain that character is shown in Table 1.

### OSD EPROM Bit Map

The mapping for the full OSD EPROM is shown in Table 2.

### Example

To program the character given above into the first character location of the OSD EPROM would require the following address/DATA sequence:

C000/00H;	C001/00H;	C002/00H;
C003/00H;	C004/0CH;	C005/1EH;
C006/0CH;	C007/1EH;	C008/0CH;
C009/1EH;	C00A/0CH;	C00B/1EH;
C00C/0CH;	C00D/1EH;	C00E/0CH;
C00F/1EH;	C010/7CH;	C011/1FH;
C012/7CH;	C013/1FH;	C014/7CH;
C015/1FH;	C016/0CH;	C017/1EH;
C018/0CH;	C019/1EH;	C01A/0CH;
C01B/1EH;	C01C/0CH;	C01D/1EH;
C01E/0CH;	C01F/1EH;	C020/00H;
C021/00H;	C022/00H;	C023/00H

# Microcontroller for television and video (MTV)

83C053/83C054/87C054

Table 1. Example of an OSD Character Bit Map

CHARACTER BIT MAP			PROGRAM DATA	
	UPPER	LOWER	UPPER	LOWER
	← — X — →			
	11111			
	43210987654321			
Line 1	→	00000000000000	X0000000	X0000000
Line 2	→	00000000000000	X0000000	X0000000
Line 3	→	00000000000000	X0000000	X0000000
Line 4	→	00111100001100	X0011110	X0001100
Line 5	→	00111100001100	X0011110	X0001100
Line 6	→	00111100001100	X0011110	X0001100
Line 7	→	00111100001100	X0011110	X0001100
Line 8	→	00111100001100	X0011110	X0001100
Line 9	→	00111100001100	X0011110	X0001100
Line 10	→	00111100001100	X0011110	X0001100
Line 11	→	00111111111100	X0011111	X1111101
Line 12	→	00111111111100	X0011111	X1111101
Line 13	→	00111111111100	X0011111	X1111101
Line 14	→	00111111111100	X0011111	X1111101
Line 15	→	00111100001100	X0011110	X0001100
Line 16	→	00111100001100	X0011110	X0001100
Line 17	→	00111100001100	X0011110	X0001100
Line 18	→	00111100001100	X0011110	X0001100
		00111100001100	X0011110	X0001100
		00111100001100	X0011110	X0001100
		00000000000000	X0000000	X0000000
		00000000000000	X0000000	X0000000

**NOTE:**

X can be 0 or 1, and will program and verify correctly.

Table 2. OSD EPROM Bit Map

CHARACTER NO.	ADDRESS	CHARACTER LINE NO.	COMMENTS
1	C000	1	Lower byte
	C001	1	
	C002	2	Lower byte
	C003	2	
	•	•	•
	•	•	
	•	•	•
	•	•	
	C022	18	Lower byte
	C023	18	
C024–C03F	Unused	Upper byte	
2	C040–C063	1–18	Unused
	C064–C07F	Unused	
3	C080–C0A3	1–18	Unused
	C0A4–C0BF	Unused	
•	•	•	•
•	•	•	
62	CFC0–CFE3	1–18	NEWLINE
	CFE4–CFFF	Unused	
63	CFC0–CFE3	1–18	BSPACE
	CFE4–CFFF	Unused	
64	CFC0–CFE3	1–18	SPLITBSPACE
	CFE4–CFFF	Unused	

**NOTE:**

Locations 62, 63, and 64 should be programmed to 0's.

# Microcontroller for television and video (MTV)

83C053/83C054/87C054

## COMPARISON TO THE 80C51

The elements of the MTV are shown in the Block Diagram. The features of the MTV are identical to those of the 80C51, except as noted herein.

## Pinout and Testing

Since neither data nor program memory is externally expandable on the MTV, the 80C51 pins ALE, EA, and PSEN are not implemented on the MTV.

## I/O Ports

On both the 80C51 and the MTV, port 0 is open-drain, but on the 80C51 it can be used for external memory expansion while on the MTV its alternate use is for Pulse Width Modulated outputs.

On the 80C51, port 1 is 8 bits, is mostly unallocated (general purpose), and is quasi-bidirectional (that is, having a weak pullup transistor that can be overdriven). On the MTV it is a 4-bit open-drain port, and includes alternate uses for analog inputs and a PWM output.

On the 80C51, port 2 is quasi-bidirectional and can be used for external memory expansion; on the MTV, port 2 is open-drain and unallocated.

On the 80C51, port 3 is quasi-bidirectional and all eight bits have alternate uses. On the MTV, three port 3 bits have some of the same alternate uses as on the 80C51 but not necessarily on the same pins, while five pins are open-drain and unallocated.

## Idle Mode

The idle mode is not implemented on the MTV.

## Power-Down Mode

The power-down mode is not implemented on the MTV. The PCON register has the following format:

PCON							
7	6	5	4	3	2	1	0
-	-	-	-	GF1	GF0	-	-

## Interrupts

The interrupt facilities of the MTV differ from those of the 80C51 as follows:

- Since there is not a serial port, there are no interrupts nor control bits relating to this interrupt. The interrupts and their vector addresses are as follows:

Event	Program Memory Address
Reset	000
External INTO	003
Timer 0	00B
External INT1	013
Timer 1	01B
VSync Start	023

- The VSYNC input used by the On Screen Display facility can generate an interrupt. The active polarity of the pulse is programmable, as described in a later section. The interrupt occurs at the leading edge of the pulse.
- External interrupt 1 is modified so that an interrupt is generated when the input switches in either direction (on the 8051, there is a programmable choice between interrupt on a negative edge or a low level on INT1). This facility allows for software pulse-width measurement handling of a remote control.
- The IP register is not used, and the IE register is similar to that on the 80C51:

IE							
7	6	5	4	3	2	1	0
EA	-	-	EVS	ET1	EX1	ET0	EX0

## Six-Bit PWM DACs

The structure of these modules is shown in Figure 2. First, the basic MCU clock is divided by 4 to get a waveform that clocks a 6-bit counter which is common to all the PWMs, including the 14-bit one. This divided clock is hereafter called the PWM counter clock.

Each PWM block has a special function register PWMn arranged as follows:

PWMn-PWM7							
7	6	5	4	3	2	1	0
PWE	-	PV5	PV4	PV3	PV2	PV1	PV0

If the PWE bit for a particular PWM block is 1, the block is active and controls its assigned port pin; if PWE is 0 the corresponding port pin is controlled by the port. The "value" field (PV5 ... PV0) of each PWM register is compared to (the LS 6 bits of) the common counter. When the value matches, the output FF is cleared, so that the output pin is driven low. When the value rolls over to zero, the output FF is set, so that the output pin is released. Thus the output waveform has a fixed period of 64 PWM counter clocks; its duty cycle is determined by PWMn.5:0.

Three of the nine total PWMs operate as described above; for three others, both the rising and falling edges of the output are delayed by one PWM clock; for the remaining three, both edges are delayed by two PWM clocks. This feature reduces the radio-frequency emission that would otherwise occur when the counter rolled over to zero and all nine open-drain outputs were released.

## 14-Bit PWM DAC (TDAC)

This feature was partially described in the preceding section. As shown in Figure 3, the 6-bit counter used for the lower precision PWMs is in fact the least significant part of a 14-bit counter used for this facility. The nature of the counter is such that it can achieve a stable output value through its MSB, and the value can propagate through logic like that shown in Figure 3, and the logic output can be stable within one period of the PWM counter clock (e.g., 250 ns) if edge-triggered logic is used to capture the logic output, or within one phase of the PWM counter clock (e.g., 125 ns) if a phase of the PWM counter clock is used to capture the logic output. For cost and die-size reasons, it is preferable that the TDAC counter be a ripple counter.

This feature is controlled by two special function registers:

TDACL							
7	6	5	4	3	2	1	0
TD7	TD0	TD1	TD2	TD3	TD4	TD5	TD6

TDACH							
7	6	5	4	3	2	1	0
TDE	-	TD13	TD12	TD11	TD10	TD9	TD8

When software wishes to change the 14-bit value (TD0 - TD13), it should first write TDACL and then write TDACH. Alternatively, if the required precision of the duty cycle is satisfied by 6 bits or less, software can simply write TDACH. Note from Figure 3 that this block includes an "extra" 14-bit latch between TDACL/H and the comparator and other logic. The programmed value is clocked into the operative latch when the 7 low-order bits of the counter roll over to zero, provided that the software is not in the midst of loading a new 14-bit value (that is, it is not between writing TDACL and writing TDACH).

In a similar fashion to the lower-precision PWMs, this facility has an output FF that is set when the lower 7 bits of the counter overflow/wrap. The more significant 7 bits of the operative latch's programmed value are compared for equality against the less significant 7 bits of the counter, and the output FF is cleared when they match. Thus this output has a fixed period of 128 PWM counter clocks, and the duty cycle is determined by the programmed value.

For the higher-precision aspect of this feature, the 7 more-significant bits of the counter are used in a logic block with the 7 less-significant bits of the programmed value. The 7th LSB (binary value 64) of the programmed value is ANDed with the 7th MSB (128) of the counter, the 6th LSB of the value is ANDed with the counter's 6th and 7th MSBs being 10, and so on through the LSB

# Microcontroller for television and video (MTV)

83C053/83C054/87C054

of the programmed value being ANDed with the counter's 7MSBs being 100000. Then these 7 ANDed terms are ORed. If the result is true/1 at the time the 7 LSBs of the counter match the MSBs of the programmed value, the output is forced high for 1 (additional) PWM counter clock.

The result is that, if the value-64 bit of the 14-bit value is programmed to 1, every other cycle of 128 PWM counter clocks has its duty cycle stretched by one counter clock; if the value-32 bit is programmed to 1, every 4th cycle is stretched, and so on through, if the value-1 bit is programmed to 1, one cycle out of each 128 is stretched.

Assuming the external integrator can handle all this, the net effect is a PWM DAC that has the period of a 7-bit design (which makes the integrator easier and more feasible to design) with the accuracy of a 14-bit one. There is some question whether all of the least significant bits can be effectively integrated, or whether they simply act as a source of ripple in the integrated voltage. An obvious prerequisite for such precision is that the load on the voltage must be very light, like a single op amp or comparator.

The TDAC feature differs from the corresponding features of predecessor parts in several ways:

1. The 14-bit value is functionally composed of major and minor portions of 7 bits each.
2. The 14-bit value is programmed as a contiguous multi-register value that can be manipulated straight-forwardly via arithmetic instructions.
3. As discussed for the 6-bit DACs, both of the preceding parts had a feature whereby the PWM output could be inverted, redundantly with complementing the 14-bit value. This feature has been eliminated.

	ADDRESS TYPE			USE	
	DIRECT	BIT	REGISTER		
DATA MEMORY	00-07		R0-R7	On-chip RAM (R0-7 if PSW.4-3 = 00)	
	08-0F		R0-R7	On-chip RAM (R0-7 if PSW.4-3 = 01)	
	10-17		R0-R7	On-chip RAM (R0-7 if PSW.4-3 = 10)	
	18-1F		R0-R7	On-chip RAM (R0-7 if PSW.4-3 = 11)	
	20	07-00		On-chip RAM	
	21-2E	77-08		On-chip RAM	
	2F	7F-78		On-chip RAM	
	30-7F			On-chip RAM	
SPECIAL FUNCTION REGISTERS	80	87-80	P0	Port 0	
	81		SP	Stack Pointer	
	82		DPL	Data Pointer LSBYTE	
	83		DPH	Data Pointer MSBYTE	
	87	8F-88	PCON	Power Control	
	88		TCON	Timer Control	
	89		TMOD	Timer Mode	
	8A		TL0	Timer 0 LSBYTE	
	8B		TL1	Timer 1 LSBYTE	
	8C		TH0	Timer 0 MSBYTE	
	8D		TH1	Timer 1 MSBYTE	
	90		97-90	P1	Port 1
	98	9F-98	OSAT	On Screen Attributes	
	99		OSDT	On Screen Data	
	9A		OSAD	On Screen Address	
	A0		A7-A0	P2	Port 2
	A8	AF-A8	IE	Interrupt Enable	
	B0	B7-B0	P3	Port 3	
	C0	C7-C0	OSCON	On Screen Display Control	
	C1		OSMOD	On Screen Display Mode	
	C2		OSORG	On Screen Display Origin	
	C3		RAMCHR	For Test Use Only	
	C4		RAMATT	For Test Use Only	
	D0		D7-D0	PSW	Program Status Word
	D2			TDACL	Hi-Res Pulse Width Modulator
	D3			TDACH	Hi-Res Pulse Width Modulator
	D4-D7		PWM0-3	Lo-Res Pulse Width Modulators	
	D8	DF-D8	SAD	D/A and Voltage Comparator	
	DC-DF		PWM4-7	Lo-Res Pulse Width Modulators	
	E0		E7-E0	A	Accumulator
	F0		F7-F0	B	B Register

↑  
ON-CHIP RAM  
IF ACCESSED  
INDIRECTLY  
↓

Figure 1. Data Memory and Special Function Registers on the MTV

# Microcontroller for television and video (MTV)

83C053/83C054/87C054

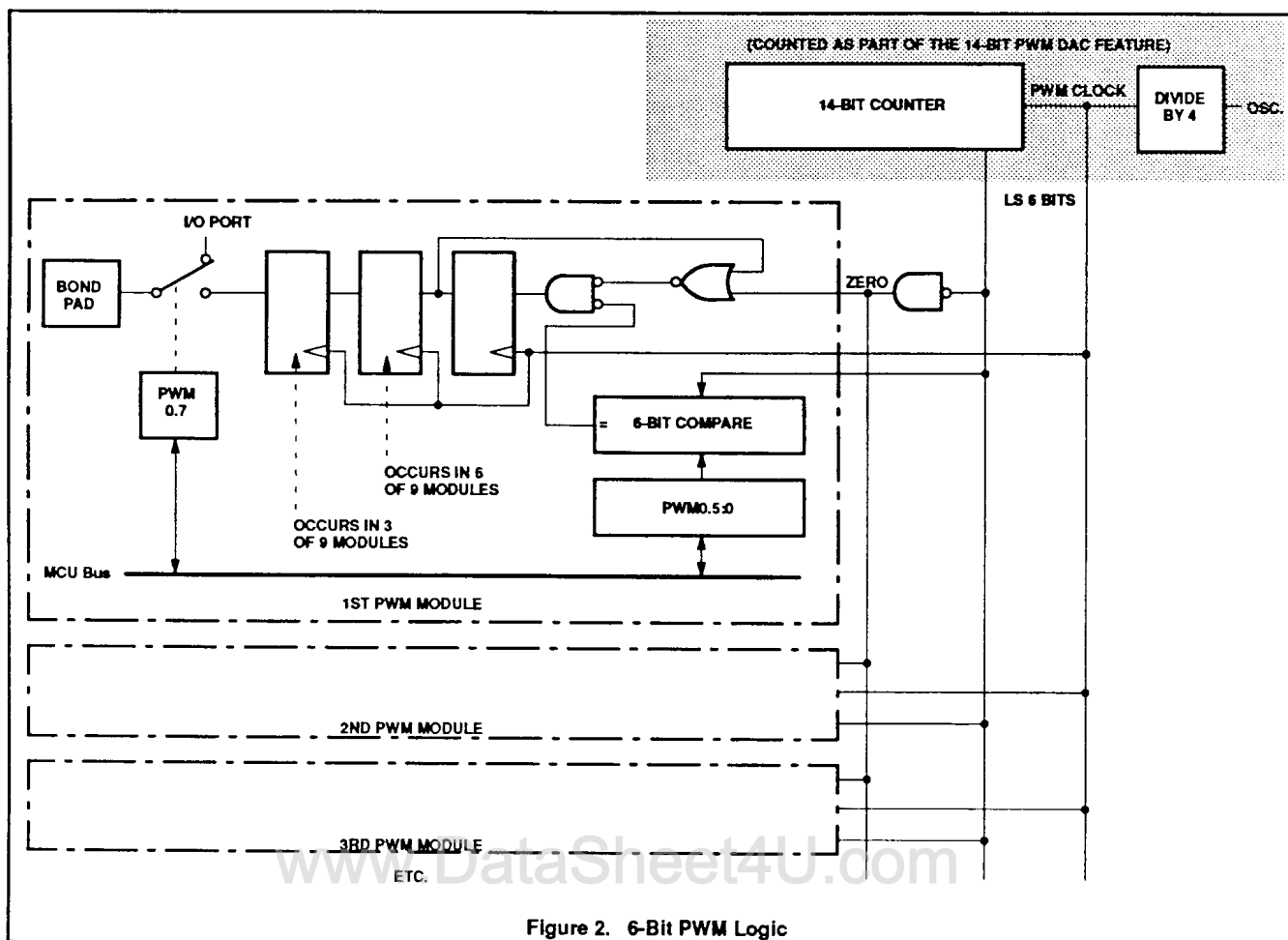

Figure 2. 6-Bit PWM Logic

## Software A/D Facility

This facility is shown in Figure 4. It represents an alternate use whereby any of the P1.0 through P1.2 pins can be selected as one input of a linear voltage comparator. The block includes one special function register:

SAD							
7	6	5	4	3	2	1	0
VH1	CH1	CH0	St	SAD3	SAD2	SAD1	SAD0

As shown in Figure 4 the other input of the comparator is connected to a 4-bit D/A that is controlled by the 4 LSBs of the SAD register, producing a reference voltage nominally 0.15625V to 4.84375V by steps of 0.3125V. The output of the comparator (high/low) can be read by the program as the MSB of the register, which is bit addressable.

The St bit should be written as 1 in order to initiate a voltage comparison. After writing St=1, the program should include intervening instructions totalling at least six machine cycles (72 CLK periods or 6 microseconds at

12MHz), before the instruction that accesses and tests VH1.

The chan field controls which pin, if any, is connected to this facility:

CH1	CH0	pin
0	0	none
0	1	P1.0
1	0	P1.1
1	1	P1.2

Port 1 has open-drain drivers which will not materially affect an analog voltage as long as any and all pins used for software A/D measurement have corresponding ones in the port register.

## On Screen Display (OSD) Module

This block is the largest of the additions that are specific to this product. Its basic function is to superimpose text on the television video image, to indicate various parameters and settings of the receiver or tuner. External circuitry handles the mixing (multiplexing) of the text and the TV video.

The overall OSD block has four input pins: two for a video clock, plus the horizontal and vertical sync signals. The video clock pins are used to connect an LC circuit to an on-chip video oscillator that is independent of the normal MCU clock. The L and C values are chosen so that a video pulse, of a duration equal to the VCLK period, will produce a more-or-less square dot on the screen, that is, a dot having a width approximately equal to the vertical distance between consecutive scan lines.

The video oscillator is stopped (with VCLK2 low) while horizontal sync is asserted, and is released to operate at the trailing edge of horizontal sync. This technique helps provide uniform horizontal positioning of characters/dots from one scan line to the next.

The block has four outputs, three color video signals, and a control signal. Since this block is the major feature of the part, its main inputs and outputs are dedicated pins, without alternate port bits.



# Microcontroller for television and video (MTV)

## 83C053/83C054/87C054

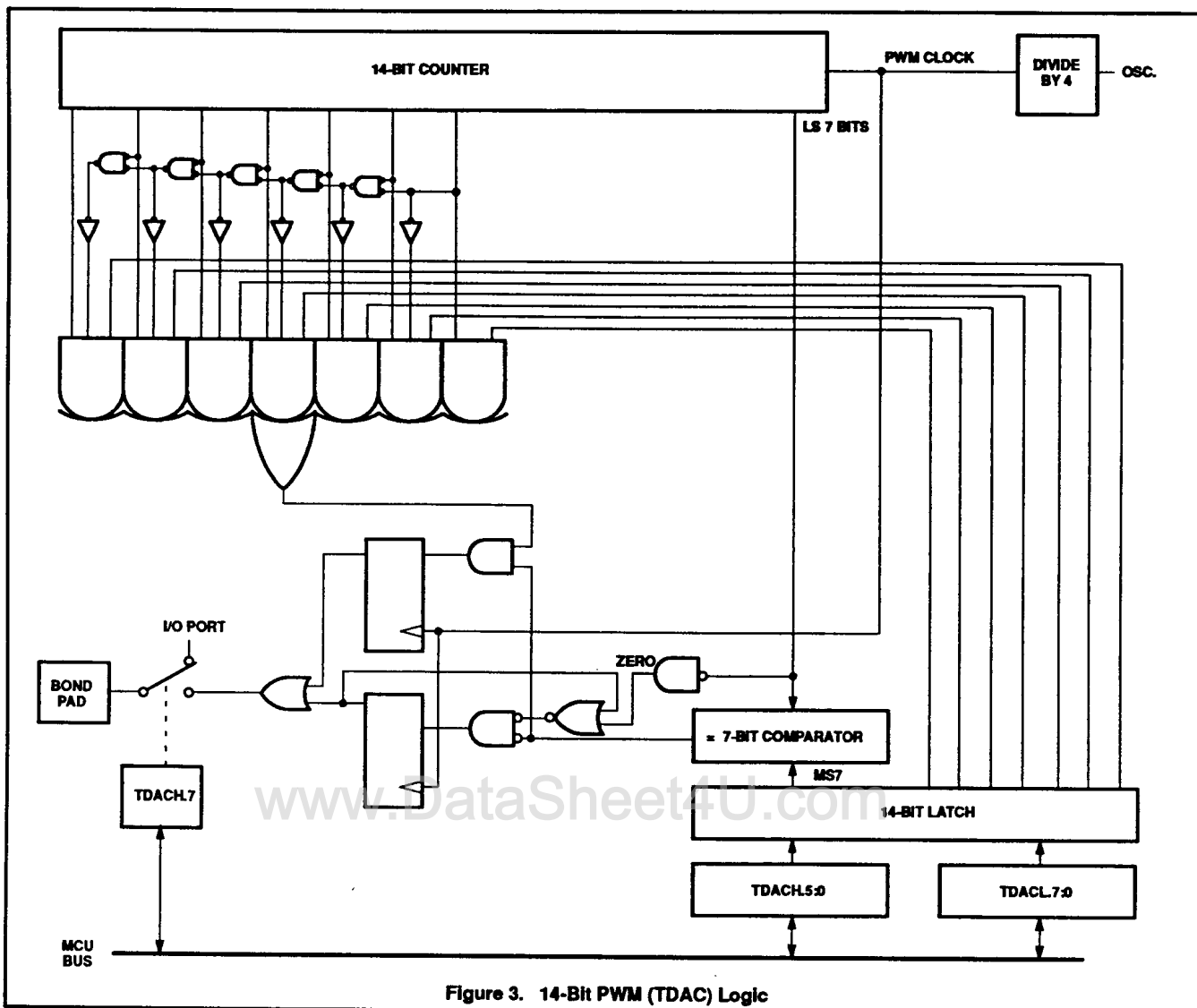

Figure 3. 14-Bit PWM (TDAC) Logic

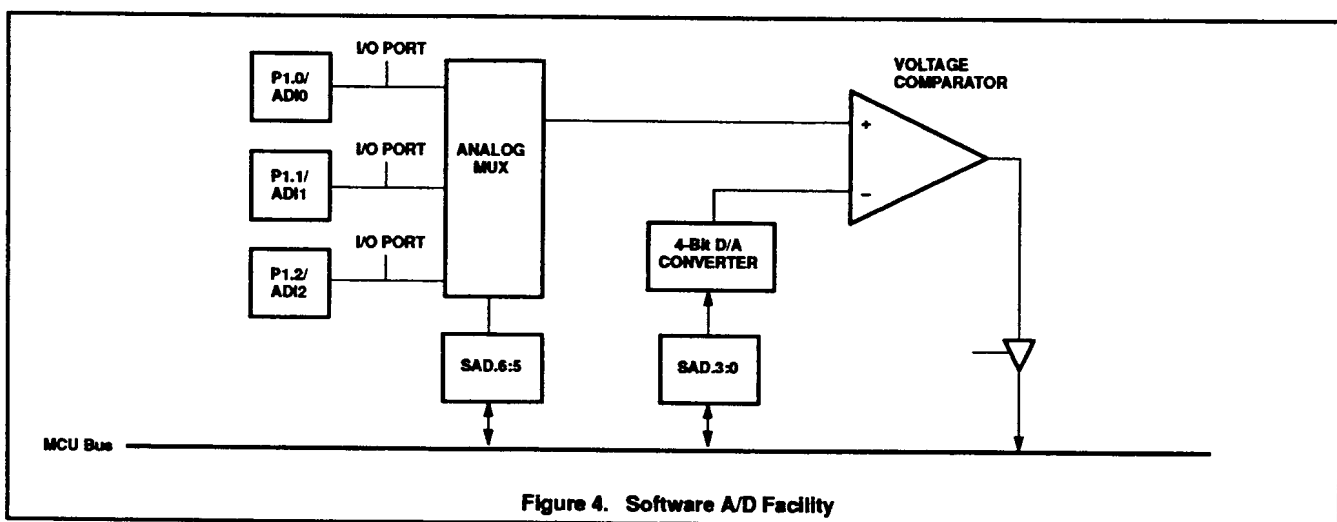

Figure 4. Software A/D Facility

# Microcontroller for television and video (MTV)

83C053/83C054/87C054

## Display RAM

The OSD of the MTV differs from that in preceding devices in one major way: It does not fix the number and size of displayed rows of text. Several predecessor parts allowed two displayed rows of 16 characters each. The MTV simply has 128 locations of display RAM, each of which can contain a displayed character or a New Line character that indicates the end of a row. A variant of the New Line character is used to indicate the end of displayed data.

The three major elements of the OSD facility are shown in the Block Diagram. Each display RAM location includes 6 data bits and 4 attribute bits. The 6 data bits from display RAM, along with a line-within-row count, act as addresses into the character generator ROM, which contains 60 displayable bit maps (64 minus one for each of New Line and three Space characters). Each bit map includes 18 scan lines by 14 dots. The character generator ROM is maskable or programmable along with the program ROM to allow for various character sets and languages.

The programming interface to display RAM is provided by three special function registers:

### OSAD

7	6	5	4	3	2	1	0
-	OSAD6	OSAD5	OSAD4	OSAD3	OSAD2	OSAD1	OSAD0

### OSDT

7	6	5	4	3	2	1	0
-	-	OSDT5	OSDT4	OSDT3	OSDT2	OSDT1	OSDT0

### OSAT (with OSDT = New Line)

7	6	5	4	3	2	1	0
-	-	-	E	-	SR	D	Sh

### OSAT (with OSDT = BSpace or SplitBspace)

7	6	5	4	3	2	1	0
-	-	-	B	-	BC2	BC1	BC0

### OSAT (with OSDT = any other)

7	6	5	4	3	2	1	0
-	-	-	B	-	FC2	FC1	FC0

OSAD ("On Screen Address") contains the address at which data will next be written into display RAM, while the ten active bits in OSDT ("On Screen Data") plus OSAT ("On Screen Attributes") correspond exactly to the 10 bits in each display RAM location. FColor indicates the color of foreground (1) pixels in the ROM bit map for this character, while B indicates whether background (0) pixels should show the current background color (B=1) or television video (B=0). Thus, for the 1 bits in a character's bit map, the VID2:0 pins are driven with (FColor) and VCTRL is driven active, while for 0 bits VID2:0 are driven with the background color (except for shadow bits) and VCTRL is driven with the B bit.

Writing OSAT simply latches the attribute bits into a register, while writing OSDT causes the data bus information, plus the contents of the OSAT register, to be written into display RAM. Thus, for a given display RAM location, OSAT should be written before OSDT. If successive characters are to be written into display RAM with the same attributes, OSAT need not be rewritten for each character, only prior to writing OSDT for the first character with those particular attributes.

In reality, there is a potential conflict between the timing of a write to OSDT and an access to display RAM by the OSD logic for data display. This is resolved by the use of a true dual-ported RAM for display memory.

OSAD is automatically incremented by one after each time OSDT and display RAM are written. Except in special test modes that are beyond the scope of this spec release, display RAM cannot be read by the MCU program.

The OSAT attribute bits associated with the BSpace (data=111110), SplitBspace (111111), and New Line (111101) characters are interpreted differently from those that accompany other data characters. With BSpace and SplitBspace, B is interpreted as described above, but the 3 color bits specify the Background color (BColor) for subsequent characters. For BSpace, a change in B and BColor becomes effective at the left edge of the character's bit map. For SplitBspace, a change in B and BColor

occurs halfway through the character horizontally. The normal Space character (111100) has no effect on the BColor value.

BColor values 000 and 111 minimize the occurrence of transient states among the VID2:0 outputs.

The background color defined by the most recently encountered BSpace or SplitBspace character is maintained on the VID2:0 pins except at the following times:

1. During the active time of HSYNC,
2. During the active time of VSYNC,
3. During those pixels of an active character that correspond to a 1 in the character's bit map,
4. During a "shadow" bit.

The BColor value is not cleared between vertical scans, so that if a single background color is all that is needed in an application, it can be set via a single BSpace character during program initialization, and never changed thereafter. In order for such a BSpace to actually affect the MTV's internal BColor register the Mode field of the OSMOD register must be set to 01 (or higher) so that the OSD hardware is operating.

With a New Line character, if the E bit is 1, no further rows are displayed on the screen. If E is 0 and D is 1, all of the characters in the following row are displayed with Double height and width. If E is 0 and Sh is 1, all of the characters in the following row are displayed with shadowing, as described in a later section. If E is 0 and SR is 1, the next row is a "short row": It is only 4 or 8 scan lines high rather than 18 or 36. Short rows can be used for underlined text.

The latches in which the E, D, Sh, and SR bits are captured are cleared to zero at the start of each vertical scan. This means that if the first text line on the screen is a short row, or if it contains either double size or shadowing, the text must be preceded by a New Line character. Like all such characters, this initial New Line advances the vertical screen position; the VStart value (see below) should take this fact into account.

# Microcontroller for television and video (MTV)

83C053/83C054/87C054

## Other OSD Registers

A number of changes in the OSD architecture have reduced the number of other special function registers involved in the feature, below the number needed with predecessor devices:

1. The elimination of certain options such as 4, 6, or 8X character sizes and alternate use of two of the video outputs.
2. The moving of certain other options from central registers to display RAM, such as foreground color codes and background selection.

### OSCON

7	6	5	4	3	2	1	0
IV	Pv	Lv	Ph	Pc	Po	DH	BF <sub>e</sub>

The IV bit is the interrupt flag for the OSD feature. It is set by the leading edge of the VSYNC pulse, and is cleared by the hardware when the VSYNC interrupt routine is vectored to. It can also be set or cleared by software writing a 1 or 0 to this bit.

### NOTE

It is theoretically possible that a VSYNC interrupt could be missed, or an extra one generated, if OSCON is read, then modified internally (e.g., in Ac), and the result written back to OSCON. However, none of the other bits in OSCON are reasonable candidates for dynamic change. Special provisions are included in the MTV logic so that IV will not be changed by a single "read-modify-write" instruction such as SETB or CLR, unless the instruction specifically changes IV.

A 0 (1) in Pv designates that the VSYNC input is high-active (low-active). One effect of this bit is that the VID2:0 and VCTRL outputs are blocked (held at black/inactive) during the active time of VSYNC. The IV bit is set on the leading edge of the VSYNC pulse; thus Pv controls whether the OSD interrupt occurs in response to a high-to-low or low-to-high transition on VSYNC.

A 0 (1) in Lv designates that the leading edge (active level) of VSYNC, as defined by Pv, clears the state counter that is used to determine the vertical start of on-screen data. In effect, Lv=0(1) says that the leading (trailing) edge of VSYNC is the time reference for the video field.

A 0 (1) in Ph designates that the HSYNC input is high-active (low-active).

A 0 (1) in Pc designates that a high (low) on the VCTRL output means "show the color on VID2:0".

A 0 (1) in Po designates that a 0 (1) internal to the MTV corresponds to a low on one of the VID2:0 pins. This control bit is needed only because the Shadowing feature needs to generate black pixels without reference to a register value: Internally, the 3-bit code 000 always designates black.

If DH is 1, character sizes are doubled vertically but not horizontally. This feature allows the MTV to be used in "improved definition" systems that are not interlaced. The vertical doubling imposed by DH does not affect the VStart logic described below: It operates in HSync units regardless of DH or D.

If BF<sub>e</sub> is 1, the BF output tracks whether each bit in displayed characters is a foreground bit (low) or a background bit (high). If BF<sub>e</sub> is 0, the BF pin remains high.

### OSORG

7	6	5	4	3	2	1	0
HS4	HS3	HS2	HS1	HS0	VS2	VS1	VS0

The HStart field (HS4 – HS0) defines the left end (start) of all of the on-screen character rows, as a multiple of four VCLKs. Active display begins 4(HStart)+1 VCLKs plus one single-sized character width after the trailing edge of HSYNC. Counting variations in Wc, there may be 17 to 143 VCLKs from the end of HSYNC to the start of the first character of each row.

The VStart field (VS2 – VS0) defines the top (start) of the first on-screen character row, as a multiple of four HSYNC pulses. Active display begins 4(VStart)-1 HSYNCs after the field's time reference point, a range of 3 to 31. Subsequent character rows occur directly below the first, such that the last scan line of one row is directly followed by the first scan line of the next row. Successive New Line characters (with or without the Short Row designation) can be used to vertically separate text rows on the screen.

Neither the HStart nor VStart parameter is affected by the D line attribute that is used to display double-sized characters.

### OSMOD

7	6	5	4	3	2	1	0
Wc	-	Mode1	Mode0	-	SHM2	SHM1	SHM0

If the mode bits (Mode 1, Mode 0) are 00, the OSD feature is disabled. The VCLK oscillator is disabled, VID2:0 are set to black, and

VCTRL is held inactive. This is the mode to which the MTV OSD logic is reset. A direct transition from this mode to active display (1x) would result in undefined operation and visual effects for the duration of the current video field (until the next VSYNC).

If the mode is 01, the VCLK oscillator is enabled and the OSD logic operates normally internally, but VID2:0 are set to black and VCTRL is held inactive. The OSD feature can be toggled between this state and 1x as desired to achieve real-time special effects such as "vertical wiping."

Mode 10 represents normal OSD operation. Active characters can be shown against TV video (for characters with B=0) or (for characters with B=1) against a background of the color defined as an attribute of BSpace and SplitBspace characters.

In mode 11, characters can be displayed but all of the receiver's normal video is inhibited by holding VCTRL asserted throughout the active portion of each scan line. Since VID2:0 are driven with the current background color during this time, except during the foreground portion of displayed characters, this produces text against a solid background. This mode is useful for extensive displays that require user concentration.

If Wc is 1, then each displayed character is horizontally terminated after 12 bits have been output, as opposed to after 14 bits if Wc is 0. This allows text to be "packed" more tightly so that more characters can be displayed per line. In effect, the 2 bits out of the display ROM, which would otherwise be the rightmost 2 of the 14, are ignored when Wc is 1. Clearly, if this feature is to be used, it must be accounted for in the design of the bit maps in the display ROM.

The 3-bit ShMode field (SHM2 – SHM0) determines how characters are shadowed in rows for which the SH row attribute is 1. As shown in Figure 5, the values 000-110 indicate an apparent light source position ranging from the lower left clockwise to the lower right, while the value 111 indicates full-surround shadowing.

Under some conditions writing to OSMOD while the display is active can cause a temporary flicker during that display field. This can be avoided by only writing to OSMOD during the vertical sync interval.

# Microcontroller for television and video (MTV)

## 83C053/83C054/87C054

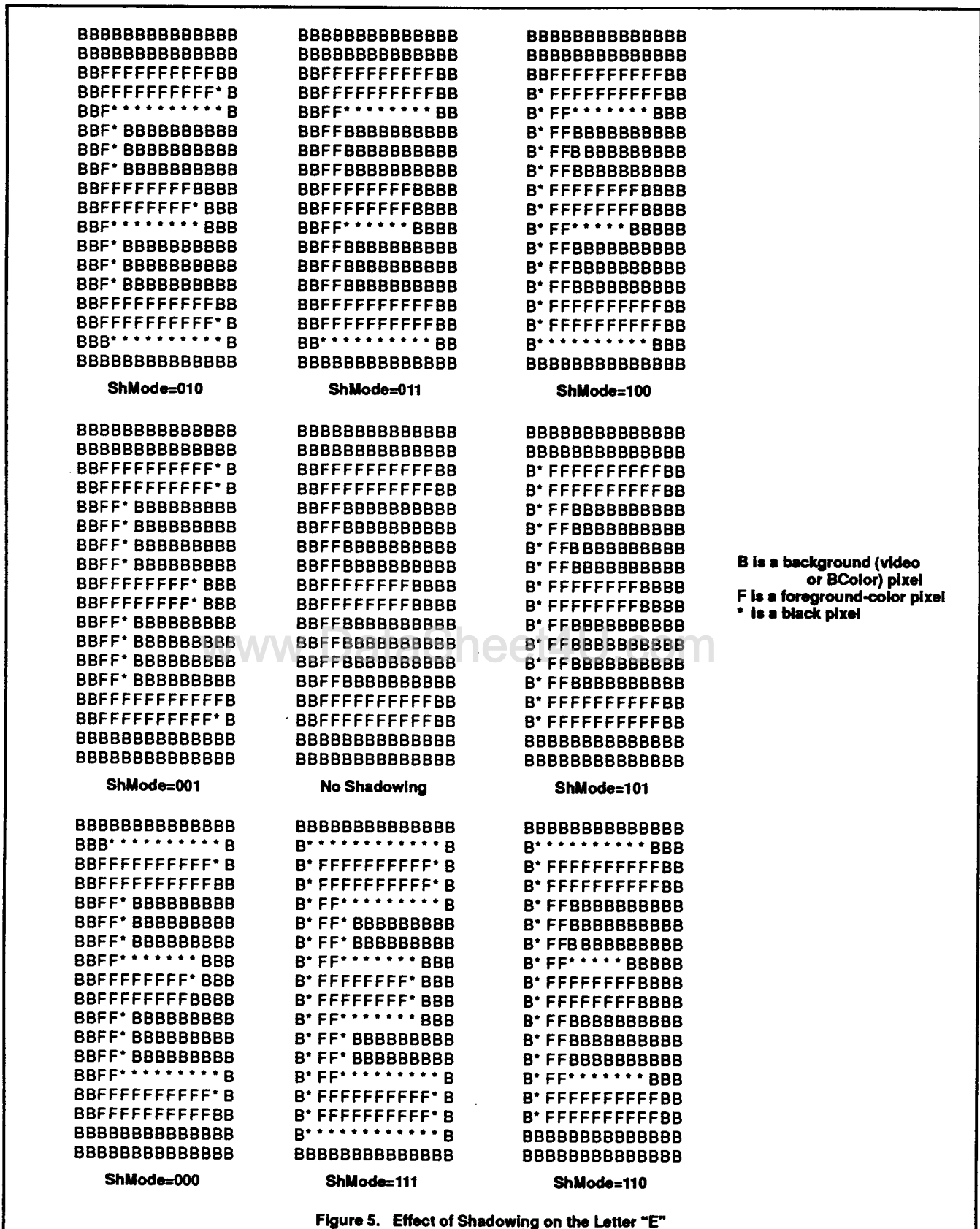

Figure 5. Effect of Shadowing on the Letter "E"

# Microcontroller for television and video (MTV)

83C053/83C054/87C054

## DC ELECTRICAL CHARACTERISTICS

 $V_{CC} = 5V \pm 10\%$ ,  $T_{amb} = 0^{\circ}C$  to  $+70^{\circ}C$ 

SYMBOL	PARAMETER	TEST CONDITIONS	LIMITS		UNIT	NOTES
			MIN	MAX		
$V_{IL}$	Input low voltage		-0.5	$0.2V_{CC}-0.1$	V	
$V_{IL1}$	Input low voltage (VSYNC, HSYNC)		-0.5	$0.16 \times V_{CC}$	V	
$V_{IH1}$	Input high voltage (P1.2:0, P2.7:0, P3.6:5, P3.3:1, VSYNC, HSYNC)		$0.2V_{CC}+0.9$	$V_{CC}+0.5$	V	
$V_{IH2}$	Input high voltage (port 0, P1.3, P3.7, P3.4, P3.0)		$0.2V_{CC}+0.9$	12.6	V	
$V_{IH3}$	Input high voltage (VSYNC)		$0.6 \times V_{CC}$	$V_{CC} + 0.5V$	V	
$V_{IH} - V_{CC}$	Input high voltage (port 0, P1.3, P3.7, P3.4, P3.0) with respect to $V_{CC}$			8	V	1
$V_{IH}$	Input high voltage (XTAL1, VCLK1, RST)		$0.7V_{CC}$	$V_{CC}+0.5$	V	
$V_{OL1}$	Output low voltage (P2.3:0, P3.6:5)	$I_{OL} = 10mA$		0.5	V	5
$V_{OL2}$	Output low voltage (TDAC, PWM0:7)	$I_{OL} = 700\mu A$		0.5	V	2
$V_{OL3}$	Output low voltage (all other outputs)	$I_{OL} = 1.6mA$		0.45	V	
$V_{OH}$	Output high voltage (port 1, VID2:0, VCTRL, BF)	$I_{OH} = -60\mu A$	2.4		V	
$R_{RST}$	Reset pulldown resistor		50	300	k $\Omega$	
$C_{IO}$	Pin capacitance	Test freq = 1MHz, $T_{amb} = 25^{\circ}C$		10	pF	4
$I_{PD}$	Power-down current	$V_{CC} = 2$ to $6V$		5	mA	
$I_{CC}$	Normal mode supply current	$V_{CC} = 5.5V$		30	mA	3
HYS	Hysteresis (VSYNC, HSYNC)	Either HSYNC polarity	0.8		V	

### NOTES:

1. This maximum applies at all times, including during power switching, and must be accounted for in power supply design. During a power-on process, the +12 volt source used for external pullup resistors should not precede the  $V_{CC}$  of the MTV up their respective voltage ramps by more than this margin, nor, during a power-down process, should  $V_{CC}$  precede +12V down their respective voltage ramps by more than this margin.
2. The specified current rating applies when any of these pins is used as a Pulse Width modulated output. For use as a port output, the rating is as given subsequently.
3.  $I_{CC}$  measured with OSD block initialized and Reset remaining low.
4. The capacitance of pins P0.0 and P0.7 for the 87C054 exceeds 10pF. P0.0 is 40pF maximum, while P0.7 is 20pF maximum.
5. No more than 6 (any 6) of these 10 high current outputs may be used at the  $V_{OL1}$  ( $I_{OL} = 10mA$ ) specification. The other 4 should comply with the  $V_{OL3}$  specification ( $I_{OL} = 1.6mA$ ).

# Microcontroller for television and video (MTV)

83C053/83C054/87C054

## AC ELECTRICAL CHARACTERISTICS

 $V_{CC} = 5V \pm 10\%$ ,  $T_{amb} = 0^{\circ}C$  to  $+70^{\circ}C$ 

SYMBOL	PARAMETER	TENTATIVE LIMITS		UNIT	NOTES
		MIN	MAX		
$1/t_{CLCL}$	XTAL Frequency	6	12	MHz	1
$t_{CHCX}$	XTAL1 Clock high time	20		ns	2
$t_{CLCX}$	XTAL1 Clock low time	20		ns	2
$t_{CLCH}$	XTAL1 Clock rise time		20	ns	2
$t_{CLCL}$	XTAL1 Clock fall time	5	20	ns	2
$1/t_{VCLCL}$	VCLK Frequency	5	8	MHz	
$ t_{VCOH1} - t_{VCOL1} $	Rise vs. fall time skew on any one of VID2:0, VCTRL, BF		40	ns	3
$ t_{VCOH1} - t_{VCOH2} $	Rise time skew between any two of VID2:0, VCTRL, BF		30	ns	3
$ t_{VCOL1} - t_{VCOL2} $	Fall time skew between any two of VID2:0, VCTRL, BF		30	ns	3

### NOTES:

1. The MTV is tested at its maximum XTAL frequency, but not at any other (lower) rate.
2. These parameters apply only when an external clock signal is used.
3. These parameters assume equal loading at  $C_L = 100pF$ , for all the referenced outputs. These parameters are specified but not tested.

## PROGRAMMING CONSIDERATIONS

### EPROM Characteristics

The 87C054 is programmed by using a modified Quick-Pulse Programming algorithm similar to that used for devices such as the 87C51. It differs from these devices in that a serial data stream is used to place the 87C751 in the programming mode.

Figure 6 shows a block diagram of the programming configuration for the 87C054. Port pin P0.0 is used as the programming voltage supply input ( $V_{PP}$  signal). Port pin P0.1 is used as the program (PGM) signal. This pin is used for the 25 programming pulses.

Port 2 is used as the address input for the byte to be programmed and accepts both the high and low components of the eleven bit address. Multiplexing of these address components is performed using the ASEL input. The user should drive the ASEL input high and then drive port 2 with the high order bits of the address. ASEL should remain high for at least 13 clock cycles. ASEL may then be driven low which latches the high order bits of the address internally. The high address should remain on port 2 for at least two clock cycles after ASEL is driven low. Port 2 may then be driven with the low byte of the address. The low address will be internally stable 13 clock cycles later. The address will remain stable provided that the low byte placed on port 2 is held stable and ASEL is kept low. **Note:** ASEL needs to be

pulsed high only to change the high byte of the address.

Port 3 is used as a bidirectional data bus during programming and verify operations. During programming mode, it accepts the byte to be programmed. During verify mode, it provides the contents of the EPROM location specified by the address which has been supplied to Port 2.

The XTAL1 pin is the oscillator input and receives the master system clock. This clock should be between 1.2 and 6MHz.

The RESET pin is used to accept the serial data stream that places the 87C054 into various programming modes. This pattern consists of a 10-bit code with the LSB sent first. Each bit is synchronized to the clock input, X1.

### Programming Operation

Figures 7 and 8 show the timing diagrams for the program/verify cycle. RESET should initially be held high for at least two machine cycles. P0.1 (PGM) and P0.0 ( $V_{PP}$ ) will be at  $V_{OH}$  as a result of the RESET operation. At this point, these pins function as normal quasi-bidirectional I/O ports and the programming equipment may pull these lines low. However, prior to sending the 10-bit code on the RESET pin, the programming equipment should drive these pins high ( $V_{IH}$ ). The RESET pin may now be used as the serial data input for the data stream which places the 87C054 in the programming mode. Data bits are sampled during the clock high time and thus should only change during the

time that the clock is low. Following transmission of the last data bit, the RESET pin should be held low.

Next the address information for the location to be programmed is placed on port 2 and ASEL is used to perform the address multiplexing, as previously described. At this time, port 1 functions as an output.

A high voltage  $V_{PP}$  level is then applied to the  $V_{PP}$  input (P0.0). (This sets Port 1 as an input port). The data to be programmed into the EPROM array is then placed on Port 3. This is followed by a series of programming pulses applied to the PGM/ pin (P0.1). These pulses are created by driving P0.1 low and then high. This pulse is repeated until a total of 25 programming pulses have occurred. At the conclusion of the last pulse, the PGM/ signal should remain high.

The  $V_{PP}$  signal may now be driven to the  $V_{OH}$  level, placing the 87C054 in the verify mode. (Port 3 is now used as an output port). After four machine cycles (48 clock periods), the contents of the addressed location in the EPROM array will appear on Port 3.

The next programming cycle may now be initiated by placing the address information at the inputs of the multiplexed buffers, driving the  $V_{PP}$  pin to the  $V_{PP}$  voltage level, providing the byte to be programmed to Port 3 and issuing the 26 programming pulses on the PGM/ pin, bringing  $V_{PP}$  back down to the  $V_{OH}$  level and verifying the byte. (See Table 3.)

# Microcontroller for television and video (MTV)

83C053/83C054/87C054

## Erase Characteristics

Erase of the EPROM begins to occur when the chip is exposed to light with wavelengths shorter than approximately 4,000 angstroms. Since sunlight and fluorescent lighting have wavelengths in this range, exposure to these light sources over an extended time (about 1 week in sunlight, or 3 years in room level fluorescent lighting) could cause inadvertent

erasure. For this and secondary effects, it is recommended that an opaque label be placed over the window. For elevated temperature or environments where solvents are being used, apply Kapton tape Flourless part number 2345-5 or equivalent.

The recommended erasure procedure is exposure to ultraviolet light (at 2537

angstroms) to an integrated dose of at least 15W-s/cm<sup>2</sup>. Exposing the EPROM to an ultraviolet lamp of 12,000μW/cm<sup>2</sup> rating for 20 to 39 minutes, at a distance of about 1 inch, should be sufficient.

Erase leaves the array in an all 1s state.

**Table 3. Implementing Program/Verify Modes**

OPERATION	SERIAL CODE	P0.1 (PGM/)	P0.0 (V <sub>PP</sub> )
Program user EPROM	286H	—*	V <sub>PP</sub>
Verify user EPROM	286H	V <sub>IH</sub>	V <sub>IH</sub>

### NOTE:

\* Pulsed from V<sub>IH</sub> to V<sub>IL</sub> and returned to V<sub>IH</sub>.

## EPROM PROGRAMMING AND VERIFICATION

T<sub>amb</sub> = 21°C to +27°C, V<sub>CC</sub> = 5V ±10%, V<sub>SS</sub> = 0V

SYMBOL	PARAMETER	MIN	MAX	UNIT
1/t <sub>CLCL</sub>	Oscillator/clock frequency	1.2	6	MHz
t <sub>AVGL</sub> *	Address setup to P0.1 (PROG-) low	10μs + 24t <sub>CLCL</sub>		
t <sub>GHAX</sub>	Address hold after P0.1 (PROG-) high	48t <sub>CLCL</sub>		
t <sub>DVGL</sub>	Data setup to P0.1 (PROG-) low	38t <sub>CLCL</sub>		
t <sub>DVGL</sub>	Data setup to P0.1 (PROG-) low	38t <sub>CLCL</sub>		
t <sub>GHDX</sub>	Data hold after P0.1 (PROG-) high	36t <sub>CLCL</sub>		
t <sub>SHGL</sub>	V <sub>PP</sub> setup to P0.1 (PROG-) low	10		μs
t <sub>GHSL</sub>	V <sub>PP</sub> hold after P0.1 (PROG-)	10		μs
t <sub>GLGH</sub>	P0.1 (PROG-) width	90	110	μs
t <sub>AVQV</sub> **	V <sub>PP</sub> low (V <sub>CC</sub> ) to data valid		48t <sub>CLCL</sub>	
t <sub>GHGL</sub>	P0.1 (PROG-) high to P0.1 (PROG-) low	10		μs
t <sub>SYNL</sub>	P0.0 (sync pulse) low	4t <sub>CLCL</sub>		
t <sub>SYNH</sub>	P0.0 (sync pulse) high	8t <sub>CLCL</sub>		
t <sub>MASEL</sub>	ASEL high time	13t <sub>CLCL</sub>		
t <sub>MAHLD</sub>	Address hold time	2t <sub>CLCL</sub>		
t <sub>HASET</sub>	Address setup to ASEL	13t <sub>CLCL</sub>		
t <sub>ADSTA</sub>	Low address to address stable	13t <sub>CLCL</sub>		

### NOTES:

\* Address should be valid at least 24t<sub>CLCL</sub> before the rising edge of P0.0 (V<sub>PP</sub>).

\*\* For a pure verify mode, i.e., no program mode in between, t<sub>AVQV</sub> is 14t<sub>CLCL</sub> maximum.

# Microcontroller for television and video (MTV)

83C053/83C054/87C054

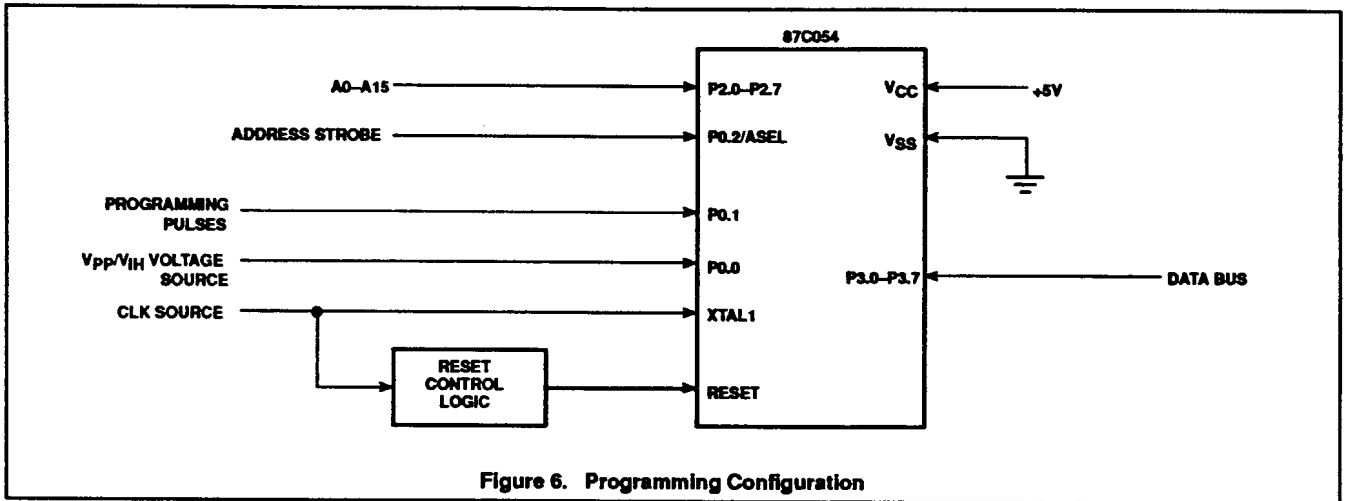

Figure 6. Programming Configuration

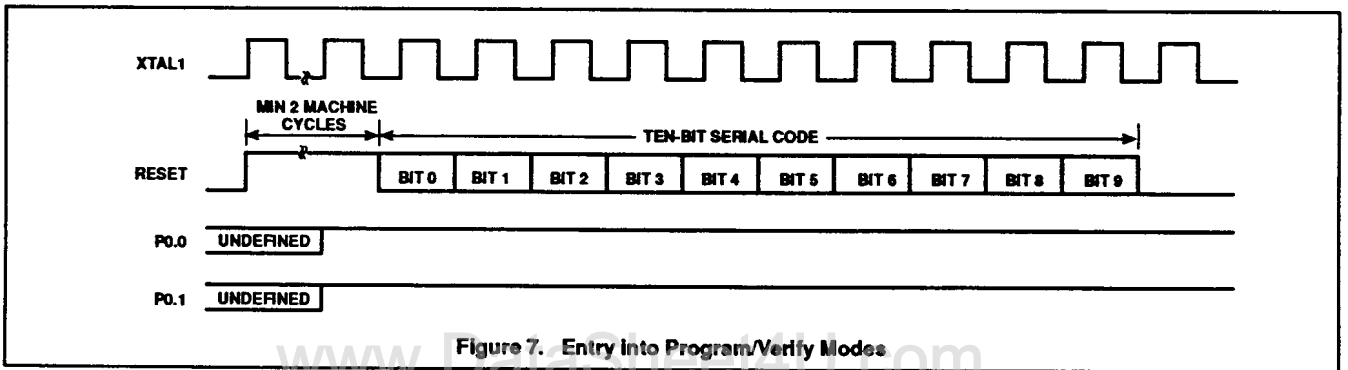

Figure 7. Entry into Program/Verify Modes

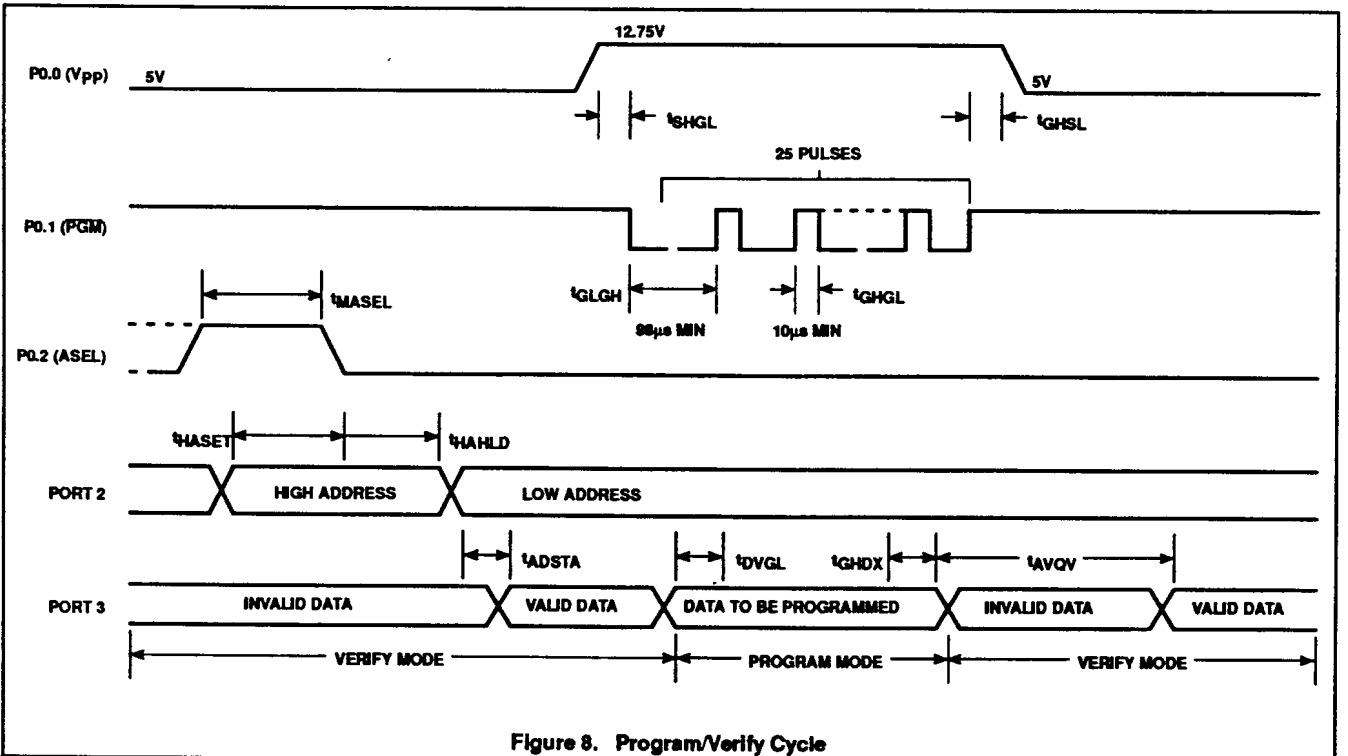

Figure 8. Program/Verify Cycle