

- Low Power Consumption : 35  $\mu$ A (TYP.)
- Dropout Voltage : 60mV @ 30mA  
: 200mV @ 100mA
- Maximum Output Current : more than 300mA (380mA limit)
- Highly Accurate :  $\pm$  2%
- VR Setting Output Voltage Range : 0.9V ~ 5.6V
- Detect Voltage Setting Range : 0.9V ~ 5.5V ( $V_{IN} \geq 2.0V$ )
- Low ESR capacitor compatible

### ■ APPLICATIONS

- Mobile phones, Cordless phones
- Wireless communication equipment
- Cameras, Video recorders
- Portable games
- Portable AV equipment
- Reference voltage
- Battery powered equipment

### ■ GENERAL DESCRIPTION

The XC6403 series are highly precise, low noise, positive voltage low dropout regulators with built-in voltage detector. They are fabricated using Torex's CMOS process. Performance features of the series includes high ripple rejection and low dropout voltage, and the series features a voltage reference, an error amplifier, a current limiter and a phase compensation circuit plus a driver transistor.

Detect voltage is selectable in 100mV increments within the range of 0.9V to 5.5V and the LDO output voltage is selectable within a range of 0.9V to 5.6V, also in 100mV increments.

The series is also compatible with low ESR ceramic capacitors which give added output stability. This stability can be maintained even during load fluctuations due to the excellent transient response of the series.

The current limiter's foldback circuit also operates as a short circuit protection for the output current limiter and the output pin.

The series provides options to the user to select from a variety of circuit features, such as detector monitoring, detector output logic, CE and EN pin input logic, and internal pull-up / down resistance.

The IC's internal regulator circuit can be placed in stand-by mode via the EN function (XC6403 A to C series). The whole IC can be put in to stand-by mode via the CE function with the XC6403D series (semi-custom). In the stand-by mode, power consumption is greatly reduced.

The XC6403 A and B series features the toggle operation function. The regulator output can be OFF when the XC6403B series detects voltage (semi-custom).

The XC6403E series can monitor another power source by using the VSEN pin (semi-custom).

The XC6403F series can delay the detector output: the delay time can be controlled by the use of an external capacitor (semi-custom).

### ■ FEATURES

Maximum Output Current	more than 300mA (380mA limit)
Dropout Voltage	200mV (I <sub>ROUT</sub> =100mA)
Operating Voltage Range	2.0V ~ 6.0V
VR Setting Output Voltage Range	0.9V ~ 5.6V (100mV step, $\pm$ 2%)
Detect Voltage Setting Range	0.9V ~ 5.5V (100mV step, $\pm$ 2%)
When monitoring VIN	more than 2.0V
VR.VD Temperature Coefficient	$\pm$ 100ppm/ $^{\circ}$ C (TYP.)
Low Power Consumption	35 $\mu$ A (TYP.)
High Ripple Rejection	65dB (@10kHz)
Low Output Noise	30mVrms
Ultra Small Packages	SOT-25 (SOT-23-5) SOT-89-5 USP-6B
Operating Temperature Range	- 40 ~ 85 $^{\circ}$ C
Low ESR Capacitor Compatible	

### ■ TYPICAL APPLICATION CIRCUITS

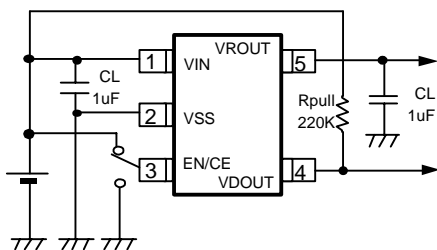

XC6403A ~ D Series

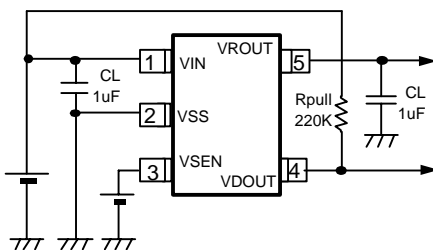

XC6403E Series

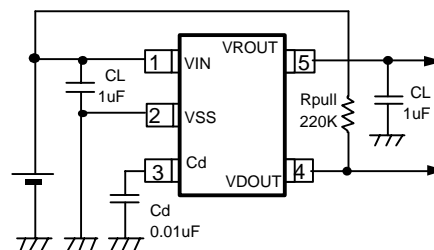

XC6403F Series

# XC6403 Series

High Speed LDO Regulators, Low ESR Cap. Compatible, Voltage Detector Function

## PIN CONFIGURATION

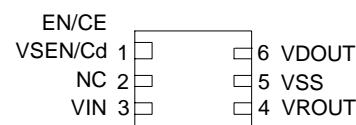
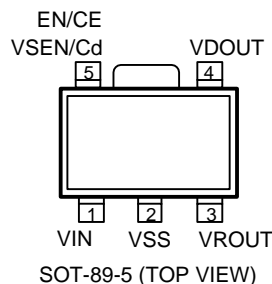
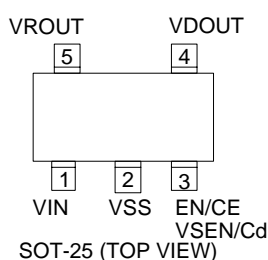

## PIN ASSIGNMENT

PIN NUMBER			PIN NAME	FUNCTION
SOT-25	SOT-89-5	USP-6B		
1	1	3	VIN	Power Input
2	2	5	VSS	Ground
3	5	1	EN	VR ON / OFF Control
3	5	1	CE	ON / OFF Control
3	5	1	VSEN	VD Monitoring
3	5	1	Cd	Delay Capacitor Connection
4	4	6	VDOUT	VD Output
5	5	4	VROUT	VR Output
-	-	2	NC	No connection

## SELECTION GUIDE

### 1. TOGGLE FUNCTION, VD SELF-SATURATION AS OPTION

SERIES	TOGGLE FUNCTION (BUILT-IN)
XC6403A	VD with Toggle Function
XC6403B	VD with Toggle Function and Self-Saturation
XC6403C ~ F	VD with no Toggle Function

### 2. STAND-BY MODE FUNCTION AS OPTION

SERIES	STAND-BY MODE FUNCTION
XC6403A ~ C	VR with Stand-by mode function
XC6403D	Chip Stand-by mode function
XC6403E, F	No Stand-by mode function

### 3. CE / EN INPUT LOGIC, INTERNAL PULL-UP/DOWN AS OPTION (\* : A ~ D Series)

SERIES	CE INPUT LOGIC
XC6403 * A ~ D	Active HIGH with pull down
XC6403 * E ~ K	Active HIGH with no pull down
XC6403 * L ~ P	Active LOW with pull up
XC6403 * R ~ U	Active LOW with no pull up

### 4. VD SENSE AS OPTION (\* : A ~ D and F Series)

SERIES	VD SENSE PIN
XC6403 * A, B, E, F, L, M, R, S, V, X	VIN
XC6403 * C, D, H, K, N, P, T, U, Y, Z	VOUT
XC6403 E V ~ Z	VSEN

### 5. VD OUTPUT LOGIC AS OPTION

SERIES	VD OUTPUT LOGIC FUNCTION
XC6403A ~ F	Detect L or Detect H

### 6. VD DELAY FUNCTION AS OPTION

SERIES	DELAY FUNCTION
XC6403A ~ E	No Delay
XC6403F	Delay time adjustable by connecting Cd

# XC6403 Series

High Speed LDO Regulators, Low ESR Cap. Compatible, Voltage Detector Function

## ORDERING INFORMATION

### XC6403 ①②③④⑤⑥

PIN NUMBER	FUNCTION	PIN NUMBER	FUNCTION
①	Optional Functions : A : Toggle and EN Function (Preliminary *) B : Toggle, EN Function, VD signal/VR OFF function (Preliminary *) C : EN Function D : CE Function E : VSEN Pin F : Cd Pin	⑤	Packaging Types:  D : USP-6B  M : SOT-25  P : SOT-89-5
②	Types : As in the chart below.	⑥	Taping Direction:  R : Embossed Tape, Standard feed  L : Embossed Tape, Reverse feed
③④	Internally set sequential number relating to output voltage and detect voltage (refer to the chart on page 4.  VR Setting Output Voltage Range : 0.9V ~ 5.6V Detect Voltage Setting Range : 0.9V ~ 5.5V 100mV step increments are available		

### PIN NUMBER : ② Types

②	EN / CE FUNCTION	EN / CE LOGIC	PULL UP/DOWN RESISTANCE	VD SENSE PIN	VD OUTPUT LOGIC	PIN NUMBER ①
A	Function	Active HIGH	Pull-down Function	VIN	Detect L	A ~ D Series
B	Function	Active HIGH	Pull-down Function	VIN	Detect H	
C	Function	Active HIGH	Pull-down Function	VROUT	Detect L	
D	Function	Active HIGH	Pull-down Function	VROUT	Detect H	
E	Function	Active HIGH	Nonfunctional	VIN	Detect L	
F	Function	Active HIGH	Nonfunctional	VIN	Detect H	
H	Function	Active HIGH	Nonfunctional	VROUT	Detect L	
K	Function	Active HIGH	Nonfunctional	VROUT	Detect H	
L	Function	Active LOW	Pull-up Function	VIN	Detect L	
M	Function	Active LOW	Pull-up Function	VIN	Detect H	
N	Function	Active LOW	Pull-up Function	VROUT	Detect L	
P	Function	Active LOW	Pull-up Function	VROUT	Detect H	
R	Function	Active LOW	Nonfunctional	VIN	Detect L	
S	Function	Active LOW	Nonfunctional	VIN	Detect H	
T	Function	Active LOW	Nonfunctional	VROUT	Detect L	
U	Function	Active LOW	Nonfunctional	VROUT	Detect H	
V	Nonfunctional	-	-	VIN / VSEN	Detect L	E & F Series
X	Nonfunctional	-	-	VIN / VSEN	Detect H	
Y	Nonfunctional	-	-	VOUT / VSEN	Detect L	F Series
Z	Nonfunctional	-	-	VOUT / VSEN	Detect H	

\* The XC6403A and XC6403B series are under development. For further detail, please ask your sales contacts.

# XC6403 Series

High Speed LDO Regulators, Low ESR Cap. Compatible, Voltage Detector Function

## ORDERING INFORMATION

○ Pin Number    ③, ④ Type    (80 ~ 99 : Standard voltage products)

(34 : Hysteresis Range 3.0% (TYP.) for an error flag)

③④	VROUT	VDOUT	③④	VROUT	VDOUT	③④	VROUT	VDOUT	③④	VROUT	VDOUT
01	1.80	2.40	21	3.30	3.10				80	1.80	1.60
02	1.80	2.90	22	2.80	3.10				81	2.80	3.10
03	1.60	1.80	23						82	1.80	2.00
04	1.80	2.00	24	1.80	2.40				83	2.50	2.80
05	3.00	3.30	25	3.20	2.80				84	2.85	3.20
06	1.80	2.40	26						85	3.00	3.30
07	1.80	2.90	27						86	3.50	3.80
08	1.80	2.00	28						87	3.00	4.20
09	3.00	3.30	29						88	3.30	4.00
10	2.80	3.10	30	4.00	4.30				89		
11	1.80	1.70	31	2.85	2.70				90		
12	3.00	4.20	32	2.60	2.40				91		
13	1.80	3.00	33	2.70	2.80				92		
14	1.80	3.00	34	2.85	2.55				93		
15	1.80	2.40	35						94		
16	2.50	2.90	36						95		
17	1.80	2.30	37						96		
18	2.80	3.40	38						97		
19			39						98		
20	3.30	3.00	40						99		

For the other voltages, please ask your sales contacts.

○ Ordering Example (Standard Products)

PRODUCT NAME	PRODUCT DESCRIPTION	VOLTAGE	
		VROUT	VDOUT
XC6403CH80MR	EN function, Active HIGH, VROUT Sense, Detect L	1.80	1.60
XC6403CE81MR	EN function, Active HIGH, VIN Sense, Detect L	2.80	3.10
XC6403DE82MR	CE function, Active HIGH, VIN Sense, Detect L	1.80	2.00
XC6403DE83MR	CE function, Active HIGH, VIN Sense, Detect L	2.50	2.80
XC6403DE84MR	CE function, Active HIGH, VIN Sense, Detect L	2.85	3.20
XC6403DE85MR	CE function, Active HIGH, VIN Sense, Detect L	3.00	3.30
XC6403DE86MR	CE function, Active HIGH, VIN Sense, Detect L	3.50	3.80
XC6403FV87MR	Cd function, VIN Sense, Detect L	3.00	4.20
XC6403FV88MR	Cd function, VIN Sense, Detect L	3.30	4.00

Except for the standard products, minimum ordering quantity is 15K.

# XC6403 Series

High Speed LDO Regulators, Low ESR Cap. Compatible, Voltage Detector Function

## PACKAGING INFORMATION

○ SOT-25

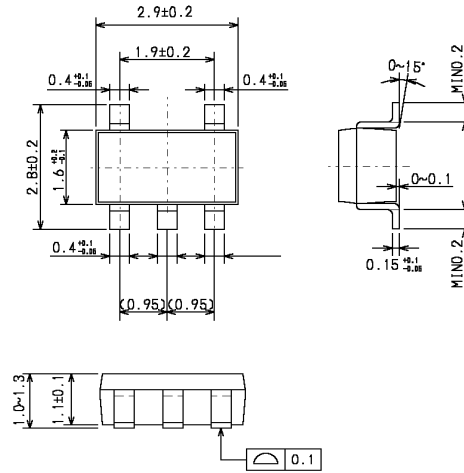

○ SOT-89-5

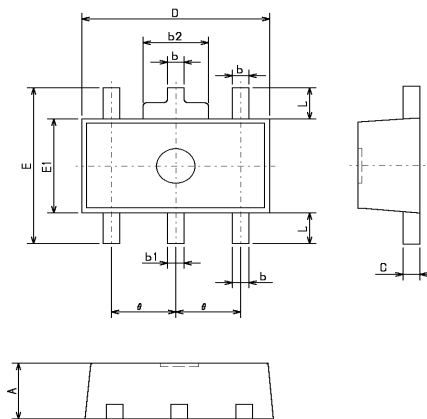

SYMBOLS	DIMENSIONS IN MILLIMETERS		
	MIN	NOM	MAX
A	1.40	1.50	1.60
b	0.36	0.42	0.48
b1	0.41	0.47	0.53
b2	1.40	1.60	1.75
C	0.38	0.40	0.43
D	4.40	4.50	4.60
E	—	—	4.25
E1	2.40	2.50	2.60
e	1.40	1.50	1.60
L	0.80	—	—

○ USP-6B

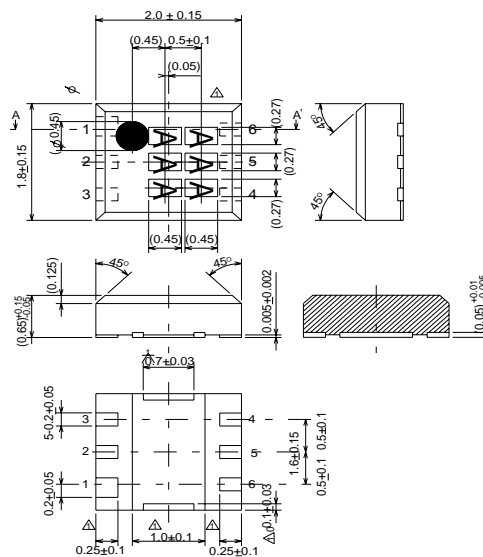

# XC6403 Series

High Speed LDO Regulators, Low ESR Cap. Compatible, Voltage Detector Function

## ■ ABSOLUTE MAXIMUM RATINGS

PARAMETER		SYMBOL	RATINGS	UNITS
Input Voltage		VIN	7.0	V
VR Output Current		VRIOUT	700	mA
VR Output Voltage		VROUT	VSS -0.3 ~ VIN +0.3	V
VD Output Current		VDIOUT	50	mA
VD Output Voltage		VDOUT	VSS -0.3 ~ 7.0	V
VCE / VSEN / Cd Pin Voltage		VCE / VSEN / Cd	VSS -0.3 ~ VIN + 0.3	V
Continuous Power Dissipation	SOT-25	Pd	250	mW
	SOT-89-5		500	
	USP-6B		100	
Operating Temperature Range		Topr	- 40 ~ + 85	°C
Storage Temperature Range		Tstg	- 55 ~ + 125	°C

## ■ ELECTRICAL CHARACTERISTICS XC6403 Series

Ta=25°C

	PARAMETER	SYMBOL	CONDITIONS	MIN	TYP	MAX	UNITS	CIRCUIT
VOLTAGE REGULATOR	VR Output Voltage (note 2, 3)	VROUT(E)	IROUT=30mA	x 0.98	VROUT(T)	x 1.02	V	①
	VR Maximum Output Current (0.9 ~ 1.7V product)	IROUTMAX	VIN = 3.1V	150			mA	①
	VR Maximum Output Current (1.8 ~ 5.3V product)	IROUTMAX	VIN=3.1V @ VROUT≤2.1V	300			mA	①
	VR Load Regulation	ΔVROUT	1mA≤IROUT≤100mA		15	50	mV	①
	VR Dropout Voltage (note 4)	Vdif1	IROUT=30mA			E-1	mV	①
		Vdif2	IROUT=100mA			E-2	mV	①
	Supply Current (No Pull-up Resistor)	IDD	VIN=VROUT(T)+1.0V, VEN/CE=ON VROUT≤0.9V VIN=2.0V VEN/CE =VIN or VSS		35	70	μA	②
	Supply Current (With Pull-up Resistor)	IDD	VIN=VROUT(T)+1.0V, VEN/CE=ON VROUT≤0.9V VIN=2.0V VEN/CE =VIN or VSS		40	75	μA	②
	VR Line Regulation	$\frac{\Delta VROUT}{\Delta VIN \cdot VROUT}$	VROUT(T)+1.0V≤VIN≤6.0V IROUT=30mA		0.01	0.20	% / V	①
	Input Voltage	VIN		2.0		6.0	V	-
	VR Output Voltage Temperature Characteristics	$\frac{\Delta VROUT}{\Delta Topr \cdot VROUT}$	IROUT=30mA -40°C≤Topr≤85°C		±100		ppm / °C	①
	VR Ripple Rejection Rate	PSRR	VIN=[VROUT(T)+1.0]V+0.5Vp-pAC When VROUT(T) ≤ 1.25V ⇒ VIN=2.25V+0.5Vp-pAC When VROUT(T) ≥ 4.75V ⇒ VIN=5.75V+0.5Vp-pAC IROUT=50mA, f=10kHz		65		dB	③
	VR Current Limiter (1.8V or more)	IRlim	VIN=3.1V @ VROUT ≤ 2.1V	300	380		mA	①
	VR Current Limiter (1.7V or less)	IRlim	VIN=3.1V		380		mA	①
Short-Circuit Current	IRshort	VIN=3.1V @ VROUT ≤ 2.1V		50		mA	①	
VOLTAGE DETECTOR	VD Detect Voltage (note 7, 8)	VDF (E)		x 0.98	VDF (T)	x 1.02	V	④
	VD Hysteresis Range (note 7)	VHYS		VDF (T) x 0.02	VDF (T) x 0.05	VDF (T) x 0.08	V	④
	VD Supply Current	IDDVD	VIN = 2.0V VIN = 3.0V VIN = 4.0V VIN = 5.0V VIN = 6.0V		6.5 7.0 7.5 8.0 9.0	14.5 15.0 15.5 16.0 17.0	μA	②
	VD Output Current (note 9)	IDOUT	VDOUT = 0.5V VIN = 2.0V VIN = 3.0V VIN = 4.0V VIN = 5.0V VIN = 6.0V	3.0 4.0 5.0 7.0 10.0	6.0 8.0 10.0 12.0 15.0		mA	⑤
	VD Detect Voltage Temperature Characteristics	$\frac{\Delta VDF}{\Delta Topr \cdot VDF}$	-40°C≤Topr≤85°C		±100		ppm / °C	④

# XC6403 Series

High Speed LDO Regulators, Low ESR Cap. Compatible, Voltage Detector Function

## ■ ELECTRICAL CHARACTERISTICS (Continued)

### XC6403 Series

Ta=25°C

PARAMETER	SYMBOL	CONDITIONS	MIN	TYP	MAX	UNITS	CIRCUIT
<b>SWITCH (NO PULLUP RESISTOR)</b>							
CE/EN "High" Level Voltage	VCE/EN H		1.60		VIN	V	①
CE/EN "Low" Level Voltage	VCE/EN L				0.25	V	①
CE/EN "High" Level Current	ICE/EN H	VCE/EN=VIN=VROUT(T)+1.0V	-0.10		0.10	μA	②
CE/EN "Low" Level Current	ICE/EN L	VIN=VROUT(T)+1.0V, VCE/EN=VSS	-0.10		0.10	μA	②
<b>OPTION</b>							
Delay Resistance	Rdelay	VIN=6.0V, Cd=0V Delay Resistance=6.0V/Delay Current	1.0	2.0	3.5	MΩ	⑥

(NOTE 1) Unless otherwise stated, VIN=VOUT(T)+1.0V

(NOTE 2) VROUT(T)=Specified VR Output Voltage

(NOTE 3) VOUT(E)=Actual VR Output Voltage

(i.e. the VR output voltage when "VROUT(T)+1.0V" is provided at the VIN pin while maintaining a certain IROUT value).

(NOTE 4)  $V_{dif} = \{VIN1^{(NOTE6)} - VROUT1^{(NOTE5)}\}$

(NOTE 5) A voltage equal to 98% of the VR Output Voltage whenever a stabilized VROUT1=IROUT{VROUT(T)+1.0V} is input.

(NOTE 6) VIN1=The Input Voltage when VOUT1, which appears as Input Voltage is gradually decreased.

(NOTE 7) VDF (T) : Specified Detect Voltage value

(NOTE 8) VDF (E) : Actual Detect Voltage value. Refer to the E-0 chart for VDF(T) values less than 1.5V.

(NOTE 9) VD Output Current value of Detect 'L' type equal to current value during detection and that of Detect 'H' type equal to current value before detection.

# XC6403 Series

High Speed LDO Regulators, Low ESR Cap. Compatible, Voltage Detector Function

## ELECTRICAL CHARACTERISTICS (Continued)

XC6403 AA / AD / AE / AH Series

Ta=25°C

	PARAMETER	SYMBOL	CONDITIONS	MIN	TYP	MAX	UNITS	CIRCUIT	
VOLTAGE REGULATOR	VR Output Voltage (note 2, 3)	VROUT(E)	IROUT=30mA	x 0.98	VROUT(T)	x 1.02	V	①	
	VR Maximum Output Current (0.9 ~ 1.7V product)	IROUTMAX	VIN = 3.1V	150			mA	①	
	VR Maximum Output Current (1.8 ~ 5.3V product)	IROUTMAX	VIN=3.1V @ VROUT ≤ 2.1V	300			mA	①	
	VR Load Regulation	ΔVROUT	1mA ≤ IROUT ≤ 100mA		15	50	mV	①	
	VR Dropout Voltage (note 4)	Vdif1	IROUT=30mA		E-1			mV	①
		Vdif2	IROUT=100mA		E-2			mV	①
	Supply Current (AA / AD Series)	IDD	VIN=VEN=VROUT(T)+1.0V		40	75	μA	②	
	Supply Current (AE / AH Series)	IDD	VIN=VEN=VROUT(T)+1.0V		35	70	μA	②	
	VR Line Regulation	$\frac{\Delta VROUT}{\Delta VIN \cdot VROUT}$	VROUT(T)+1.0V ≤ VIN ≤ 6.0V IROUT=30mA		0.01	0.20	% / V	①	
	Input Voltage	VIN		2.0		6.0	V		
	VR Output Voltage Temperature Characteristics	$\frac{\Delta VROUT}{\Delta Topr \cdot VROUT}$	IROUT=30mA -40°C ≤ Topr ≤ 85°C		±100		ppm / °C	①	
	VR Ripple Rejection Rate	PSRR	VIN=[VROUT(T)+1.0]V+0.5Vp-pAC When VROUT(T) ≤ 1.25V ⇒ VIN=2.25V+0.5Vp-pAC When VROUT(T) ≥ 4.75V ⇒ VIN=5.75V+0.5Vp-pAC IROUT=50mA, f=10kHz		65		dB	③	
	VR Current Limiter (1.8V or more)	IRlim	VIN=3.1V @ VROUT ≤ 2.1V VEN = VIN	300	380		mA	①	
	VR Current Limiter (1.7V or less)	IRlim	VIN=3.1V, VEN=VIN		380		mA	①	
Short-circuit Current	IRshort	VIN=VROUT(T)+1.0V, VEN=VIN VIN=3.1V @ VROUT ≤ 2.1V		50		mA	①		
VOLTAGE DETECTOR	VD Detect Voltage (note 7, 8)	VDF (E)		x 0.98	VDF (T)	x 1.02	V	④	
	VD Hysteresis Range (note 8)	VHYS		VDF (T) x 0.02	VDF (T) x 0.05	VDF (T) x 0.08	V	④	
	VD Supply Current (note 9)	IDDVD	VIN = 2.0V VIN = 3.0V VIN = 4.0V VIN = 5.0V VIN = 6.0V		6.5 7.0 7.5 8.0 9.0	14.5 15.0 15.5 16.0 17.0	μA	②	
	VD Output Current (note 10)	IDOUT	VDOUT = 0.5V VIN = 2.0V VIN = 3.0V VIN = 4.0V VIN = 5.0V VIN = 6.0V	3.0 4.0 5.0 7.0 10.0	6.0 8.0 10.0 12.0 15.0		mA	⑤	
	VD Detect Voltage Temperature Characteristics	$\frac{\Delta VDF}{\Delta Topr \cdot VDF}$	-40°C ≤ Topr ≤ 85°C		±100		ppm / °C	④	



# XC6403 Series

High Speed LDO Regulators, Low ESR Cap. Compatible, Voltage Detector Function

## ■ ELECTRICAL CHARACTERISTICS (Continued)

### XC6403 AA / AD / AE / AH Series

Ta=25°C

PARAMETER	SYMBOL	CONDITIONS	MIN	TYP	MAX	UNITS	CIRCUIT
<b>SWITCH</b>							
EN "High" Level Voltage	VEN H		1.60		VIN	V	①
EN "Low" Level Voltage	VEN L				0.25	V	①
EN "High" Level Current (AA / AD Series)	IEN H	VEN=VIN=VROUT(T)+1.0V	-0.10		5.00	μA	②
EN "High" Level Current (AE /AH Series)	IEN H	VEN=VIN=VROUT(T)+1.0V	-0.10		0.10	μA	②
EN "Low" Level Current	IEN L	VIN=VROUT(T)+1.0V, VEN=VSS	-0.10		0.10	μA	②

(NOTE 1) Unless otherwise stated, VIN=VOUT(T)+1.0V

(NOTE 2) VROUT(T)=Specified VR Output Voltage

(NOTE 3) VOUT(E)=Actual VR Output Voltage

(i.e. the VR output voltage when "VROUT(T)+1.0V" is provided at the VIN pin while maintaining a certain IROUT value).

(NOTE 4)  $V_{dif} = \{VIN1^{(NOTE6)} - VROUT1^{(NOTE5)}\}$

(NOTE 5) A voltage equal to 98% of the VR Output Voltage whenever a stabilized VROUT1=IROUT{VROUT(T)+1.0V} is input.

(NOTE 6) VIN1=The Input Voltage when VOUT1, which appears as Input Voltage is gradually decreased.

(NOTE 7) VDF (T) : Specified Detect Voltage value

(NOTE 8) VDF (E) : Actual Detect Voltage value. Refer to the E-0 chart for VDF(T) values less than 1.5V.

(NOTE 9) VD Supply Current = Supply Current when VEN=VSS

(NOTE 10) VD Output Current = Sink Current during detection.

# XC6403 Series

High Speed LDO Regulators, Low ESR Cap. Compatible, Voltage Detector Function

## ELECTRICAL CHARACTERISTICS (Continued)

### XC6403 CA / CD / CE / CH Series

Ta=25°C

	PARAMETER	SYMBOL	CONDITIONS	MIN	TYP	MAX	UNITS	CIRCUIT	
VOLTAGE REGULATOR	VR Output Voltage (note 2, 3)	VROUT(E)	IROUT=30mA	x 0.98	VROUT(T)	x 1.02	V	①	
	VR Maximum Output Current (0.9 ~ 1.7V product)	IROUTMAX	VIN = 3.1V	150			mA	①	
	VR Maximum Output Current (1.8 ~ 5.3V product)	IROUTMAX	VIN=3.1V @ VROUT ≤ 2.1V	300			mA	①	
	VR Load Regulation	ΔVROUT	1mA ≤ IROUT ≤ 100mA		15	50	mV	①	
	VR Dropout Voltage (note 4)	Vdif1	IROUT=30mA		E-1			mV	①
		Vdif2	IROUT=100mA		E-2			mV	①
	Supply Current (CA / CD Series)	IDD	VIN=VEN=VROUT(T)+1.0V		40	75	μA	②	
	Supply Current (CE / CH Series)	IDD	VIN=VEN=VROUT(T)+1.0V		35	70	μA	②	
	VR Line Regulation	$\frac{\Delta VROUT}{\Delta VIN \cdot VROUT}$	VROUT(T)+1.0V ≤ VIN ≤ 6.0V IROUT=30mA		0.01	0.20	% / V	①	
	Input Voltage	VIN		2.0		6.0	V		
	VR Output Voltage Temperature Characteristics	$\frac{\Delta VROUT}{\Delta Topr \cdot VROUT}$	IROUT=30mA -40°C ≤ Topr ≤ 85°C		±100		ppm / °C	①	
	VR Ripple Rejection Rate	PSRR	VIN=[VROUT(T)+1.0]V+0.5Vp-pAC When VROUT(T) ≤ 1.25V ⇒ VIN=2.25V+0.5Vp-pAC When VROUT(T) ≥ 4.75V ⇒ VIN=5.75V+0.5Vp-pAC IROUT=50mA, f=10kHz		65		dB	③	
	VR Current Limiter (1.8V or more)	IRlim	VIN=3.1V @ VROUT ≤ 2.1V VEN = VIN	300	380		mA	①	
	VR Current Limiter (1.7V or less)	IRlim	VIN=3.1V, VEN=VIN		380		mA	①	
Short-Circuit Current	IRshort	VIN=VROUT(T)+1.0V, VEN=VIN VIN=3.1V @ VROUT ≤ 2.1V		50		mA	①		
VOLTAGE DETECTOR	VD Detect Voltage (note 7, 8)	VDF (E)		x 0.98	VDF (T)	x 1.02	V	④	
	VD Hysteresis Range (note 8)	VHYS		VDF (T) x 0.02	VDF (T) x 0.05	VDF (T) x 0.08	V	④	
	VD Supply Current (note 9)	IDDVD	VIN = 2.0V VIN = 3.0V VIN = 4.0V VIN = 5.0V VIN = 6.0V		6.5 7.0 7.5 8.0 9.0	14.5 15.0 15.5 16.0 17.0	μA	②	
	VD Output Current (note 10)	IDOUT	VDOUT = 0.5V VIN = 2.0V VIN = 3.0V VIN = 4.0V VIN = 5.0V VIN = 6.0V	3.0 4.0 5.0 7.0 10.0	6.0 8.0 10.0 12.0 15.0		mA	⑤	
	VD Detect Voltage Temperature Characteristics	$\frac{\Delta VDF}{\Delta Topr \cdot VDF}$	-40°C ≤ Topr ≤ 85°C		±100		ppm / °C	④	

# XC6403 Series

High Speed LDO Regulators, Low ESR Cap. Compatible, Voltage Detector Function

## ■ ELECTRICAL CHARACTERISTICS (Continued)

### XC6403 CA / CD / CE / CH Series

Ta=25°C

PARAMETER	SYMBOL	CONDITIONS	MIN	TYP	MAX	UNITS	CIRCUIT
<b>SWITCH</b>							
EN "High" Level Voltage	VEN H		1.6		VIN	V	①
EN "Low" Level Voltage	VEN L				0.25	V	①
EN "High" Level Current (CA / CD Series)	IEN H	VEN=VIN=VROUT(T)+1.0V	-0.10		5.00	μA	②
EN "High" Level Current (CE / CH Series)	IEN H	VEN=VIN=VROUT(T)+1.0V	-0.10		0.10	μA	②
EN "Low" Level Current	IEN L	VIN=VROUT(T)+1.0V, VEN=VSS	-0.10		0.10	μA	②

(NOTE 1) Unless otherwise stated, VIN=VOUT(T)+1.0V

(NOTE 2) VROUT(T)=Specified VR Output Voltage

(NOTE 3) VOUT(E)=Actual VR Output Voltage

(i.e. the VR output voltage when "VROUT(T)+1.0V" is provided at the VIN pin while maintaining a certain IROUT value).

(NOTE 4)  $V_{dif} = (VIN1^{(NOTE6)} - VROUT1^{(NOTE5)})$

(NOTE 5) A voltage equal to 98% of the VR Output Voltage whenever a stabilized VROUT1=IROUT{VROUT(T)+1.0V} is input.

(NOTE 6) VIN1=The Input Voltage when VOUT1, which appears as Input Voltage is gradually decreased.

(NOTE 7) VDF (T) : Specified Detect Voltage value

(NOTE 8) VDF (E) : Actual Detect Voltage value. Refer to the E-0 chart for VDF(T) values less than 1.5V.

(NOTE 9) VD Supply Current = Supply Current when VEN=VSS

(NOTE 10) VD Output Current = Sink Current during detection.

# XC6403 Series

High Speed LDO Regulators, Low ESR Cap. Compatible, Voltage Detector Function

## ELECTRICAL CHARACTERISTICS (Continued)

### XC6403 DA / DD / DE / DH Series

Ta=25°C

	PARAMETER	SYMBOL	CONDITIONS	MIN	TYP	MAX	UNITS	CIRCUIT
VOLTAGE REGULATOR	VR Output Voltage (note 2, 3)	VROUT(E)	IROUT=30mA	x 0.98	VROUT(T)	x 1.02	V	①
	VR Maximum Output Current (0.9 ~ 1.7V product)	IROUTMAX	VIN = 3.1V	150			mA	①
	VR Maximum Output Current (1.8 ~ 5.3V product)	IROUTMAX	VIN=3.1V @ VROUT ≤ 2.1V	300			mA	①
	VR Load Regulation	ΔVROUT	1mA ≤ IROUT ≤ 100mA		15	50	mV	①
	VR Dropout Voltage (note 4)	Vdif1	IROUT=30mA			E-1	mV	①
		Vdif2	IROUT=100mA			E-2	mV	①
	Supply Current (DA / DD Series)	IDD	VIN=VCE=VROUT(T)+1.0V		40	75	μA	②
	Supply Current (DE / DH Series)	IDD	VIN=VCE=VROUT(T)+1.0V		35	70	μA	②
	Stand-by Current (DA / DD / DE / DH Series)	IDD	VIN=VROUT(T)+1.0V, VCE=VSS		0.01	0.10	% / V	②
	VR Line Regulation	$\frac{\Delta VROUT}{\Delta VIN \cdot VROUT}$	VROUT(T)+1.0V ≤ VIN ≤ 6.0V IROUT=30mA		0.01	0.20	% / V	①
	Input Voltage	VIN		2.0		6.0	V	
	VR Output Voltage Temperature Characteristics	$\frac{\Delta VROUT}{\Delta Topr \cdot VROUT}$	IROUT=30mA -40°C ≤ Topr ≤ 85°C			±100	ppm / °C	①
	VR Ripple Rejection Rate	PSRR	VIN=[VROUT(T)+1.0]V+0.5Vp-pAC When VROUT(T) ≤ 1.25V ⇒ VIN=2.25V+0.5Vp-pAC When VROUT(T) ≥ 4.75V ⇒ VIN=5.75V+0.5Vp-pAC IROUT=50mA, f=10kHz		65		dB	③
	VR Current Limiter (1.8V or more)	IRlim	VIN=3.1V @ VROUT ≤ 2.1V VCE = VIN	300	380		mA	①
VR Current Limiter (1.7V or less)	IRlim	VIN=3.1V, VCE=VIN		380		mA	①	
Short-Circuit Current	IRshort	VIN=VROUT(T)+1.0V, VCE=VIN VIN=3.1V @ VROUT ≤ 2.1V		50		mA	①	
VOLTAGE DETECTOR	VD Detect Voltage (note 7, 8)	VDF (E)		x 0.98	VDF (T)	x 1.02	V	④
	VD Hysteresis Range (note 8)	VHYS		VDF (T) x 0.02	VDF (T) x 0.05	VDF (T) x 0.08	V	④
	VD Output Current (note 9)	IDOUT	VROUT = 0.5V VIN = 2.0V VIN = 3.0V VIN = 4.0V VIN = 5.0V VIN = 6.0V	3.0 4.0 5.0 7.0 10.0	6.0 8.0 10.0 12.0 15.0		mA	⑤
	VD Detect Voltage Temperature Characteristics	$\frac{\Delta VDF}{\Delta Topr \cdot VDF}$	-40°C ≤ Topr ≤ 85°C			±100	ppm / °C	④
	SWITCH	CE "High" Level Voltage	VCE H		1.6		VIN	V
CE "Low" Level Voltage		VCE L				0.25	V	①
CE "High" Level Current (DA / DD Series)		ICE H	VCE=VIN=VROUT(T)+1.0V	-0.10		5.00	μA	②
CE "High" Level Current (DE / DH Series)		ICE H	VCE=VIN=VROUT(T)+1.0V	-0.10		0.10	μA	②
CE "Low" Level Current		ICE L	VIN=VROUT(T)+1.0V, VCE=VSS	-0.10		0.10	μA	②

(NOTE 1) Unless otherwise stated, VIN=VOUT(T)+1.0V

(NOTE 2) VROUT(T)=Specified VR Output Voltage

(NOTE 3) VOUT(E)=Actual VR Output Voltage

(i.e. the VR output voltage when "VROUT(T)+1.0V" is provided at the VIN pin while maintaining a certain IROUT value).

(NOTE 4)  $Vdif=(VIN1^{(NOTE6)}-VROUT1^{(NOTE5)})$

(NOTE 5) A voltage equal to 98% of the VR Output Voltage whenever a stabilized VROUT1=IROUT{VROUT(T)+1.0V} is input.

(NOTE 6) VIN1=The Input Voltage when VOUT1, which appears as Input Voltage is gradually decreased.

(NOTE 7) VDF (T) : Specified Detect Voltage value

(NOTE 8) VDF (E) : Actual Detect Voltage value. Refer to the E-0 chart for VDF(T) values less than 1.5V.

(NOTE 9) VD Output Current = Sink Current during detection.

# XC6403 Series

High Speed LDO Regulators, Low ESR Cap. Compatible, Voltage Detector Function

## ELECTRICAL CHARACTERISTICS (Continued)

### XC6403 EV / EX Series

Ta=25°C

	PARAMETER	SYMBOL	CONDITIONS	MIN	TYP	MAX	UNITS	CIRCUIT
VOLTAGE REGULATOR	VR Output Voltage	VROUT(E)	IROUT=30mA	x 0.98	VROUT(T)	x 1.02	V	①
	VR Maximum Output Current (0.9 ~ 1.7V product)	IROUTMAX	VIN = 3.1V	150			mA	①
	VR Maximum Output Current (1.8 ~ 5.3V product)	IROUTMAX	VIN=3.1V @ VROUT ≤ 2.1V	300			mA	①
	VR Load Regulation	ΔVROUT	1mA ≤ IROUT ≤ 100mA		15	50	mV	①
	VR Dropout Voltage	Vdif1	IROUT=30mA		E-1		mV	①
		Vdif2	IROUT=100mA		E-2		mV	①
	Supply Current (EV / EX Series)	IDD	VIN=VROUT(T)+1.0V		35	70	μA	②
	VR Line Regulation	$\frac{\Delta VROUT}{\Delta VIN \cdot VROUT}$	VROUT(T)+1.0V ≤ VIN ≤ 6.0V IROUT=30mA		0.01	0.20	% / V	①
	Input Voltage	VIN		2.0		6.0	V	
	VR Output Voltage Temperature Characteristics	$\frac{\Delta VROUT}{\Delta Topr \cdot VROUT}$	IROUT=30mA -40°C ≤ Topr ≤ 85°C		±100		ppm / °C	①
	Ripple Rejection Rate	PSRR	VIN=[VROUT(T)+1.0]V+0.5Vp-pAC When VROUT(T) ≤ 1.25V ⇒ VIN=2.25V+0.5Vp-pAC When VROUT(T) ≥ 4.75V ⇒ VIN=5.75V+0.5Vp-pAC IROUT=50mA, f=10kHz		65		dB	③
	VR Current Limiter (1.8V or more)	IRlim	VIN=3.1V @ VROUT ≤ 2.1V	300	380		mA	①
VR Current Limiter (1.7V or less)	IRlim	VIN=3.1V		380		mA	①	
Short-Circuit Current	IRshort	VIN=VROUT(T)+1.0V, VIN=3.1V @ VROUT ≤ 2.1V		50		mA	①	
VOLTAGE DETECTOR	VD Detect Voltage	VDF (E)		x 0.98	VDF (T)	x 1.02	V	④
	VD Hysteresis Range	VHYS		VDF (T) x 0.02	VDF (T) x 0.05	VDF (T) x 0.08	V	④
	VD Output Current (note 9)	IDOUT	VDOUT = 0.5V VIN = 2.0V VIN = 3.0V VIN = 4.0V VIN = 5.0V VIN = 6.0V	3.0 4.0 5.0 7.0 10.0	6.0 8.0 10.0 12.0 15.0		mA	⑤
	VD Detect Voltage Temperature Characteristics	$\frac{\Delta VDF}{\Delta Topr \cdot VDF}$	-40°C ≤ Topr ≤ 85°C		±100		ppm / °C	④

(NOTE 1) Unless otherwise stated, VIN=VOUT(T)+1.0V

(NOTE 2) VROUT(T)=Specified VR Output Voltage

(NOTE 3) VOUT(E)=Actual VR Output Voltage

(i.e. the VR output voltage when "VROUT(T)+1.0V" is provided at the VIN pin while maintaining a certain IROUT value).

(NOTE 4) Vdif={VIN1(NOTE6)-VROUT1(NOTE5)}

(NOTE 5) A voltage equal to 98% of the VR Output Voltage whenever a stabilized VROUT1=IROUT{VROUT(T)+1.0V} is input.

(NOTE 6) VIN1=The Input Voltage when VOUT1, which appears as Input Voltage is gradually decreased.

(NOTE 7) VDF (T) : Specified Detect Voltage value

(NOTE 8) VDF (E) : Actual Detect Voltage value. Refer E-0 chart for VDF(T) less than 1.5V.

(NOTE 9) VD Output Current = Sink Current during detection.

# XC6403 Series

High Speed LDO Regulators, Low ESR Cap. Compatible, Voltage Detector Function

## ELECTRICAL CHARACTERISTICS (Continued)

### XC6403 FV / FX / FY / FZ Series

Ta=25°C

	PARAMETER	SYMBOL	CONDITIONS	MIN	TYP	MAX	UNITS	CIRCUIT
VOLTAGE REGULATOR	VR Output Voltage (note 2, 3)	VROUT(E)	IROUT=30mA	x 0.98	VROUT(T)	x 1.02	V	①
	VR Maximum Output Current (0.9 ~ 1.7V product)	IROUTMAX	VIN = 3.1V	150			mA	①
	VR Maximum Output Current (1.8 ~ 5.3V product)	IROUTMAX	VIN=3.1V @ VROUT ≤ 2.1V	300			mA	①
	VR Load Regulation	ΔVROUT	1mA ≤ IROUT ≤ 100mA		15	50	mV	①
	VR Dropout Voltage (note 4)	Vdif1	IROUT=30mA		E-1		mV	①
		Vdif2	IROUT=100mA		E-2		mV	①
	Supply Current (FV / FX / FY / FZ Series)	IDD	VIN=VROUT(T)+1.0V		35	70	μA	②
	VR Line Regulation	$\frac{\Delta VROUT}{\Delta VIN \cdot VROUT}$	VROUT(T)+1.0V ≤ VIN ≤ 6.0V IROUT=30mA		0.01	0.20	% / V	①
	Input Voltage	VIN		2.0		6.0	V	
	VR Output Voltage Temperature Characteristics	$\frac{\Delta VROUT}{\Delta Topr \cdot VROUT}$	IROUT=30mA -40°C ≤ Topr ≤ 85°C		±100		ppm / °C	①
	Ripple Rejection Rate	PSRR	VIN=[VROUT(T)+1.0]V+0.5Vp-pAC When VROUT(T) ≤ 1.25V ⇒ VIN=2.25V+0.5Vp-pAC When VROUT(T) ≥ 4.75V ⇒ VIN=5.75V+0.5Vp-pAC IROUT=50mA, f=10kHz		65		dB	③
	VR Current Limiter (1.8V or more)	IRlim	VIN=3.1V @ VROUT ≤ 2.1V	300	380		mA	①
VR Current Limiter (1.7V or less)	IRlim	VIN=3.1V		380		mA	①	
Short-Circuit Current	IRshort	VIN=VROUT(T)+1.0V, VIN=3.1V @ VROUT ≤ 2.1V		50		mA	①	
VOLTAGE DETECTOR	VD Detect Voltage (note 7, 8)	VDF (E)		x 0.98	VDF (T)	x 1.02	V	④
	VD Hysteresis Range (note 8)	VHYS		VDF (T) x 0.02	VDF (T) x 0.05	VDF (T) x 0.08	V	④
	VD Output Current (note 9)	IDOUT	VROUT = 0.5V VIN = 2.0V VIN = 3.0V VIN = 4.0V VIN = 5.0V VIN = 6.0V	3.0 4.0 5.0 7.0 10.0	6.0 8.0 10.0 12.0 15.0		mA	⑤
	VD Detect Voltage Temperature Characteristics	$\frac{\Delta VDF}{\Delta Topr \cdot VDF}$	-40°C ≤ Topr ≤ 85°C		±100		ppm / °C	④
	Delay Resistance	Rdelay	VIN=6.0V, Cd=0V Delay Resistance=6.0V/Delay Current	1.0	2.0	3.5	MΩ	⑥

(NOTE 1) Unless otherwise stated, VIN=VOUT(T)+1.0V

(NOTE 2) VROUT(T)=Specified VR Output Voltage

(NOTE 3) VOUT(E)=Actual VR Output Voltage

(i.e. the VR output voltage when "VROUT(T)+1.0V" is provided at the VIN pin while maintaining a certain IROUT value).

(NOTE 4) Vdif={VIN1(NOTE6)-VROUT1(NOTE5)}

(NOTE 5) A voltage equal to 98% of the VR Output Voltage whenever a stabilized VROUT1=IROUT{VROUT(T)+1.0V} is input.

(NOTE 6) VIN1=The Input Voltage when VOUT1, which appears as Input Voltage is gradually decreased.

(NOTE 7) VDF (T) : Specified Detect Voltage value

(NOTE 8) VDF (E) : Actual Detect Voltage value. Refer to the E-0 chart for VDF(T) values less than 1.5V.

(NOTE 9) VD Supply Current = Sink Current during detection.

# XC6403 Series

High Speed LDO Regulators, Low ESR Cap. Compatible, Voltage Detector Function

## ■ VR DROPOUT VOLTAGE

SYMBOL	E-0		E-1		E-1	
PARAMETER  SPECIFIED DETECT VOLTAGE OUTPUT VOLTAGE	OUTPUT VOLTAGE DETECT VOLTAGE  (V)		DROPOUT VOLTAGE 1 (mV) (IOUT=30mA)  Ta=25°C		DROPOUT VOLTAGE 2 (mV) (IOUT=100mA)  Ta=25°C	
	VROUT / VDF		Vdif1	Vdif1	Vdif2	Vdif2
	VROUT(T) VDF(T)	MIN.	MAX.	TYP.	MAX.	TYP.
0.90	0.870	0.930	1050	1100	1150	1200
1.00	0.970	1.030	1000	1100	1050	1200
1.10	1.070	1.130	900	1000	950	1100
1.20	1.170	1.230	800	900	850	1000
1.30	1.270	1.330	700	800	750	900
1.40	1.370	1.430	600	700	650	800
1.50	1.470	1.530	500	600	550	700
1.60	1.568	1.632	400	500	500	600
1.70	1.666	1.732	300	400	400	500
1.80	1.764	1.836	200	300	300	400
1.90	1.862	1.938	120	150	280	380
2.00	1.960	2.040	80	120	240	350
2.10	2.058	2.142	80	120	240	330
2.20	2.156	2.244	80	120	240	330
2.30	2.254	2.346	80	120	240	310
2.40	2.352	2.448	80	120	240	310
2.50	2.450	2.550	70	100	220	290
2.60	2.548	2.652	70	100	220	290
2.70	2.646	2.754	70	100	220	290
2.80	2.744	2.856	70	100	220	270
2.90	2.842	2.958	70	100	220	270
3.00	2.940	3.060	60	90	200	270
3.10	3.038	3.162	60	90	200	250
3.20	3.136	3.264	60	90	200	250
3.30	3.234	3.366	60	90	200	250
3.40	3.332	3.468	60	90	200	250
3.50	3.430	3.570	60	90	200	250
3.60	3.528	3.672	60	90	200	250
3.70	3.626	3.774	60	90	200	250
3.80	3.724	3.876	60	90	200	250
3.90	3.822	3.978	60	90	200	250
4.00	3.920	4.080	60	80	180	230
4.10	4.018	4.182	60	80	180	230
4.20	4.116	4.284	60	80	180	230
4.30	4.214	4.386	60	80	180	230
4.40	4.312	4.488	60	80	180	230
4.50	4.410	4.590	60	80	180	230
4.60	4.508	4.692	60	80	180	230
4.70	4.606	4.794	60	80	180	230
4.80	4.704	4.896	60	80	180	230
4.90	4.802	4.998	60	80	180	230
5.00	4.900	5.100	50	70	160	210
5.10	4.998	5.202	50	70	160	210
5.20	5.096	5.304	50	70	160	210
5.30	5.194	5.406	50	70	160	210
5.40	5.292	5.508	50	70	160	210
5.50	5.390	5.610	50	70	160	210
5.60	5.488	5.712	50	70	160	210

# XC6403 Series

High Speed LDO Regulators, Low ESR Cap. Compatible, Voltage Detector Function

## TEST CIRCUITS

### ○ Circuit ①

XC6403A ~ C Series

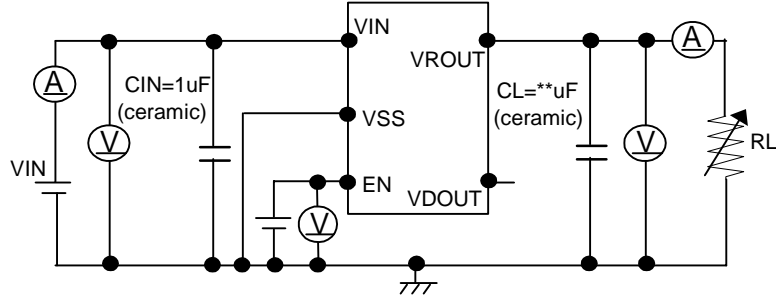

XC6403D Series

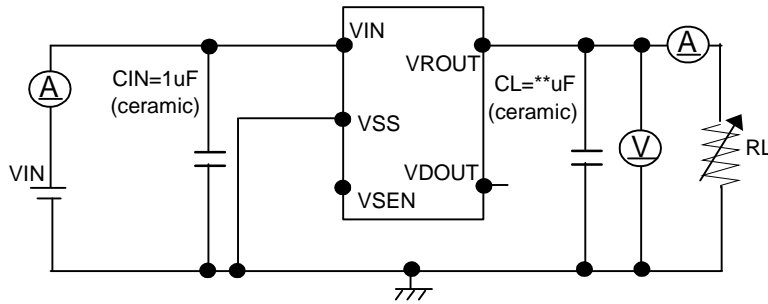

XC6403E Series

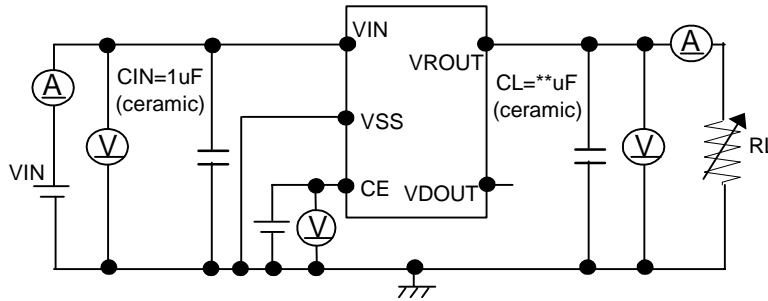

XC6403F Series

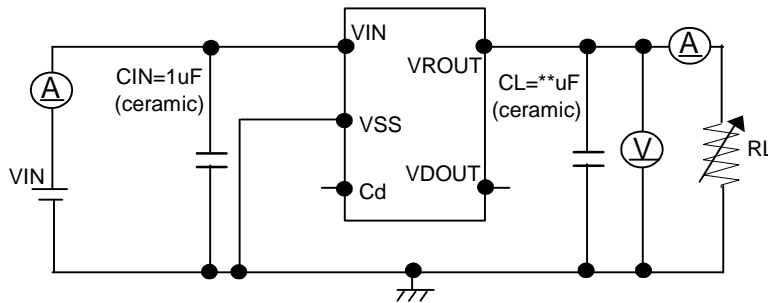

Output Capacitor Corresponding Chart

VROUT	0.9 ~ 1.2V	1.3 ~ 1.7V	1.8V ~ 5.6V
CL	more than 4.7 $\mu$ F	more than 2.2 $\mu$ F	more than 1.0 $\mu$ F



# XC6403 Series

High Speed LDO Regulators, Low ESR Cap. Compatible, Voltage Detector Function

## ■ TEST CIRCUITS (Continued)

### ○ Circuit ②

XC6403A ~ C Series

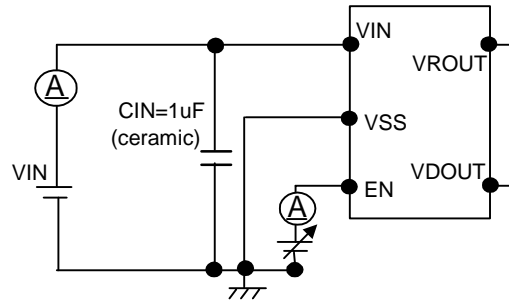

XC6403D Series

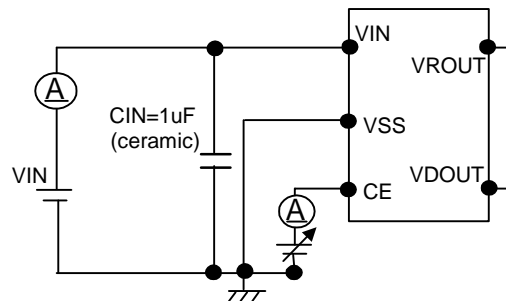

XC6403E Series

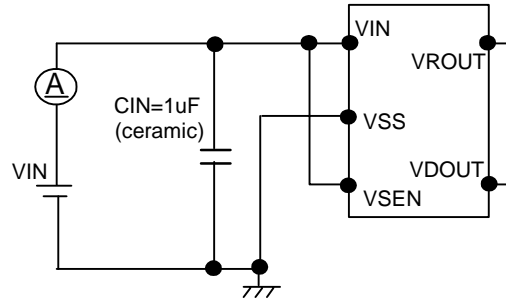

XC6403F Series

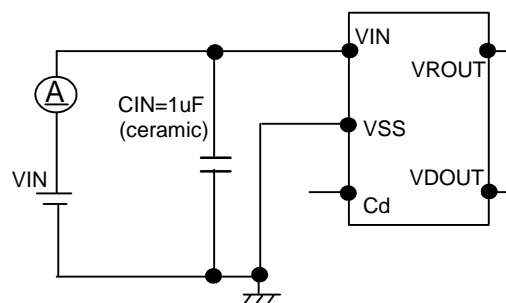

# XC6403 Series

High Speed LDO Regulators, Low ESR Cap. Compatible, Voltage Detector Function

## TEST CIRCUITS (Continued)

### ○ Circuit ③

XC6403A ~ C Series

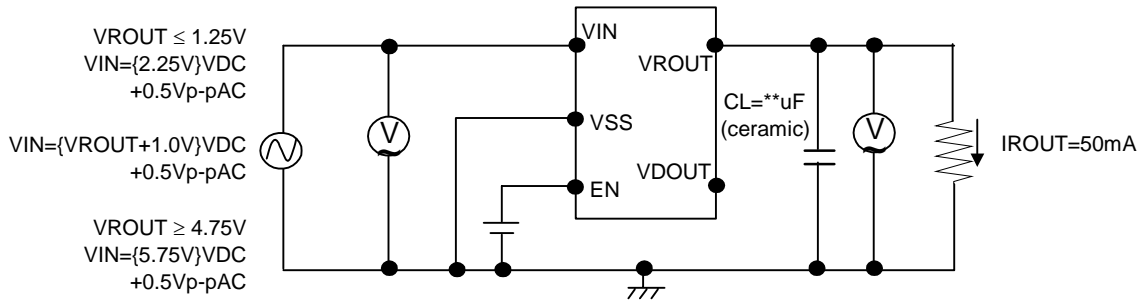

XC6403D Series

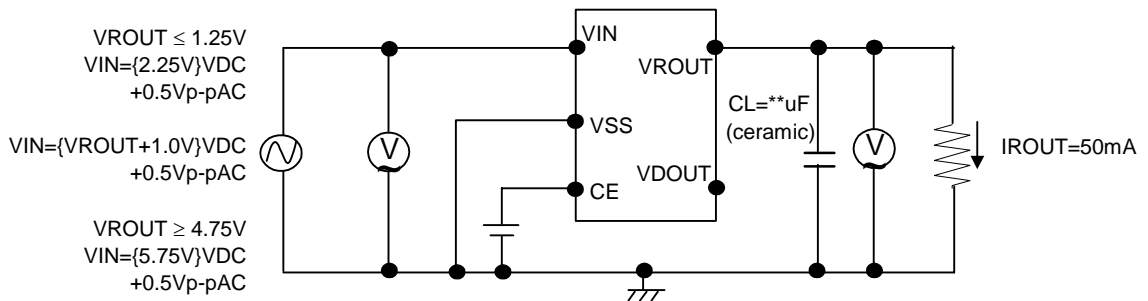

XC6403E Series

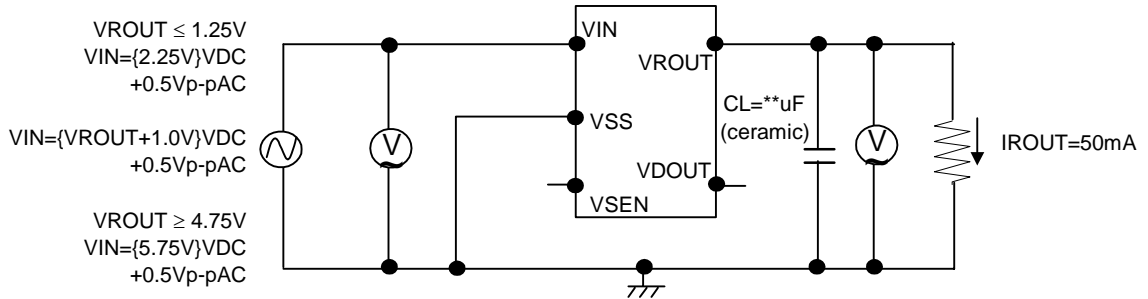

XC6403F Series

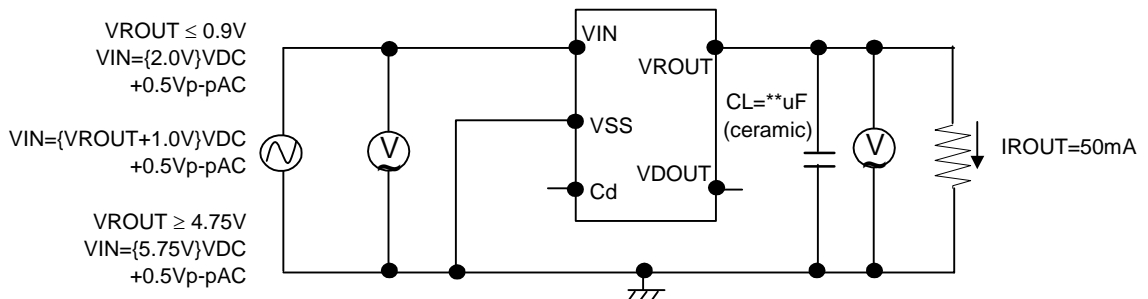

Output Capacitor Corresponding Chart

VROUT	0.9 ~ 1.2V	1.3 ~ 1.7V	1.8 ~ 5.6V
CL	more than 4.7 $\mu$ F	more than 2.2 $\mu$ F	more than 1.0 $\mu$ F

# XC6403 Series

High Speed LDO Regulators, Low ESR Cap. Compatible, Voltage Detector Function

## TEST CIRCUITS (Continued)

### ○ Circuit ④

XC6403A ~ C Series

[VD Sense, VIN type]

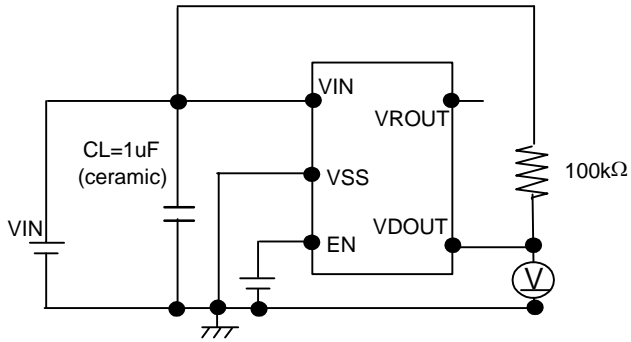

[VD Sense, VROUT type]

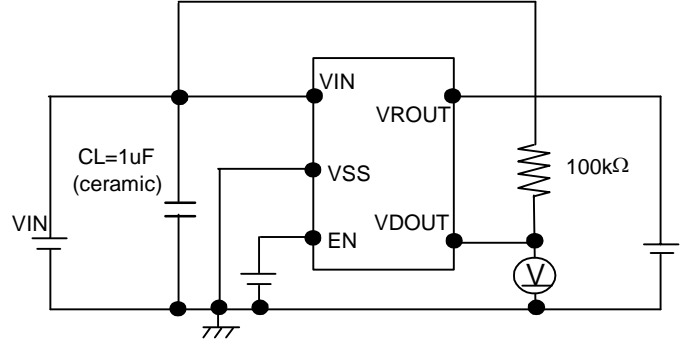

XC6403D Series

[VD Sense, VIN type]

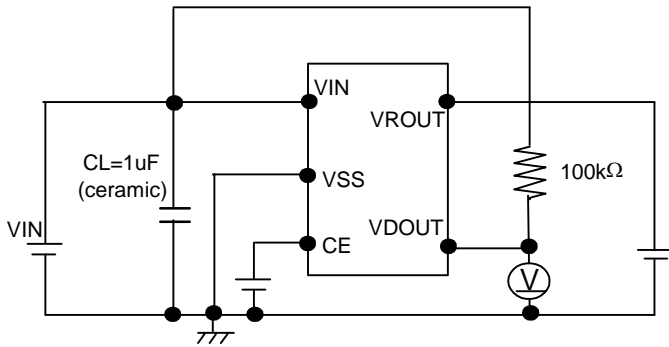

[VD Sense, VROUT type]

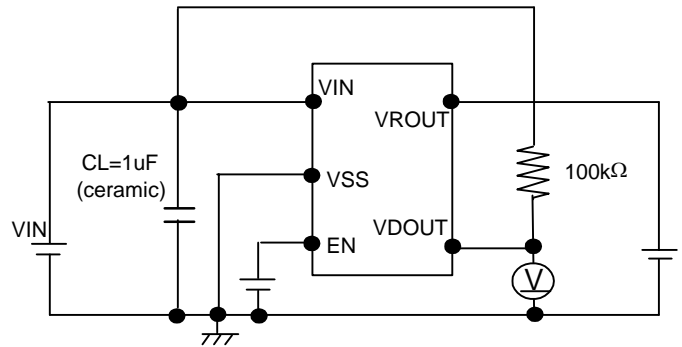

XC6403E Series

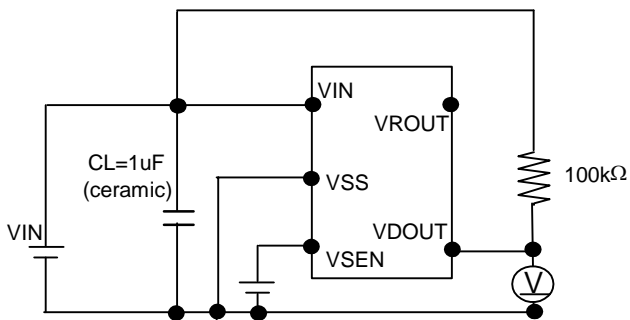

XC6403F Series

[VD Sense, VIN type]

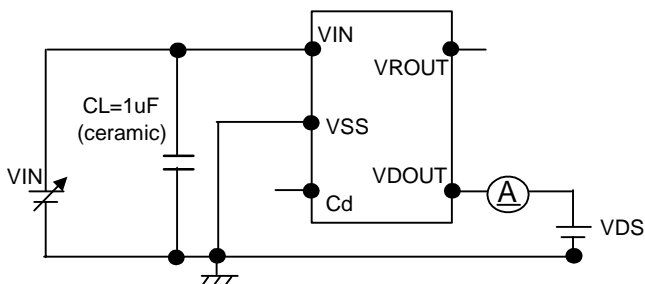

[VD Sense, VROUT type]

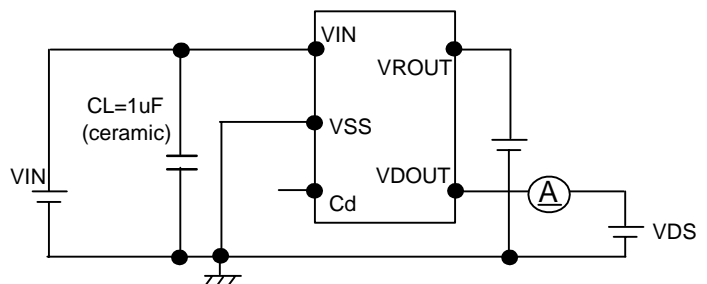

# XC6403 Series

High Speed LDO Regulators, Low ESR Cap. Compatible, Voltage Detector Function

## TEST CIRCUITS (Continued)

### ○ Circuit ⑤

XC6403A ~ C Series

[VD Sense, VIN type]

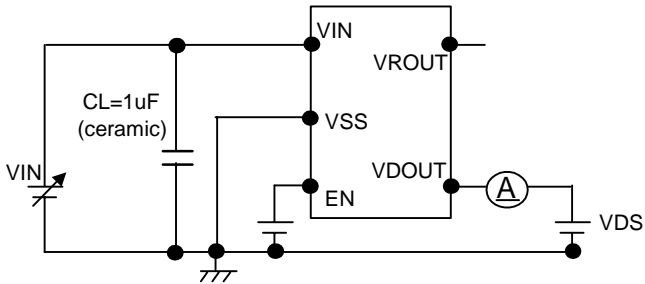

[VD Sense, VROUT type]

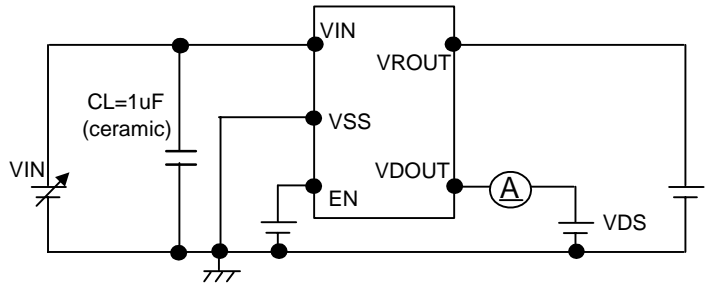

XC6403D Series

[VD Sense, VIN type]

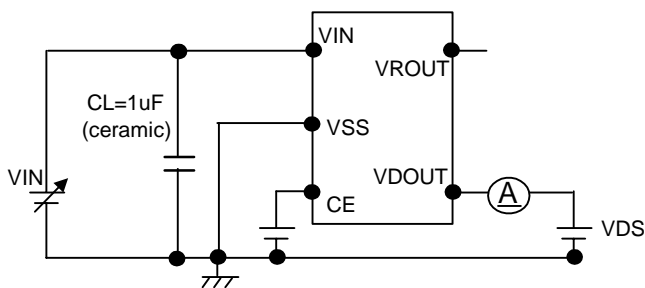

[VD Sense, VROUT type]

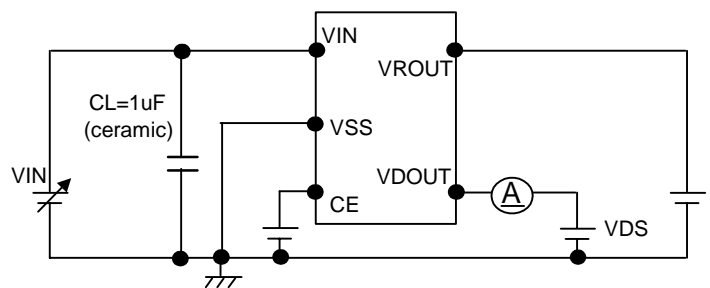

XC6403E Series

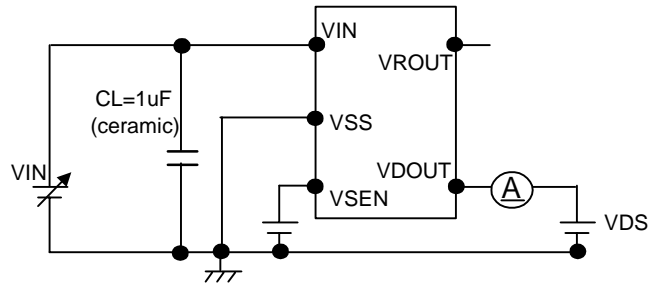

XC6403F Series

[VD Sense, VIN type]

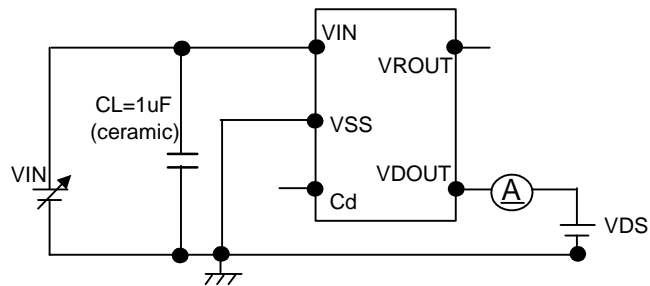

[VD Sense, VROUT type]

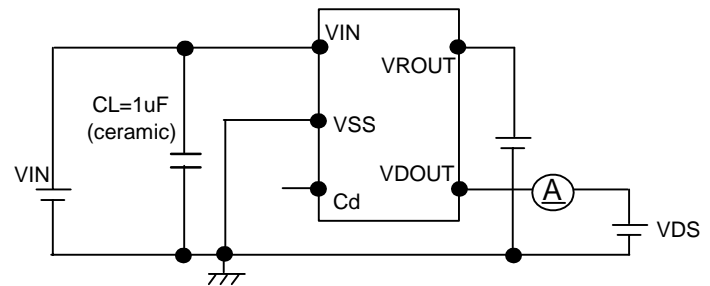

# XC6403 Series

High Speed LDO Regulators, Low ESR Cap. Compatible, Voltage Detector Function

## ■ TEST CIRCUITS (Continued)

### ○ Circuit ⑥

XC6403F Series  
[VD Sense, VIN type]

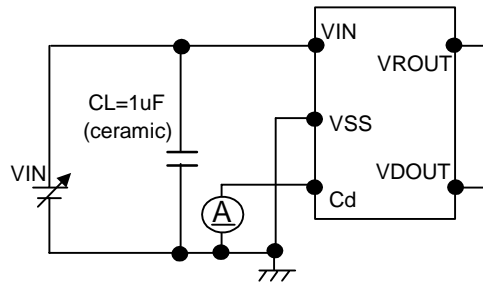

[VD Sense, VROUT type]

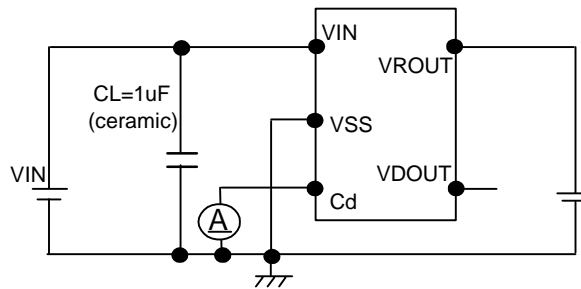

# XC6403 Series

High Speed LDO Regulators, Low ESR Cap. Compatible, Voltage Detector Function

## ■ BLOCK DIAGRAMS

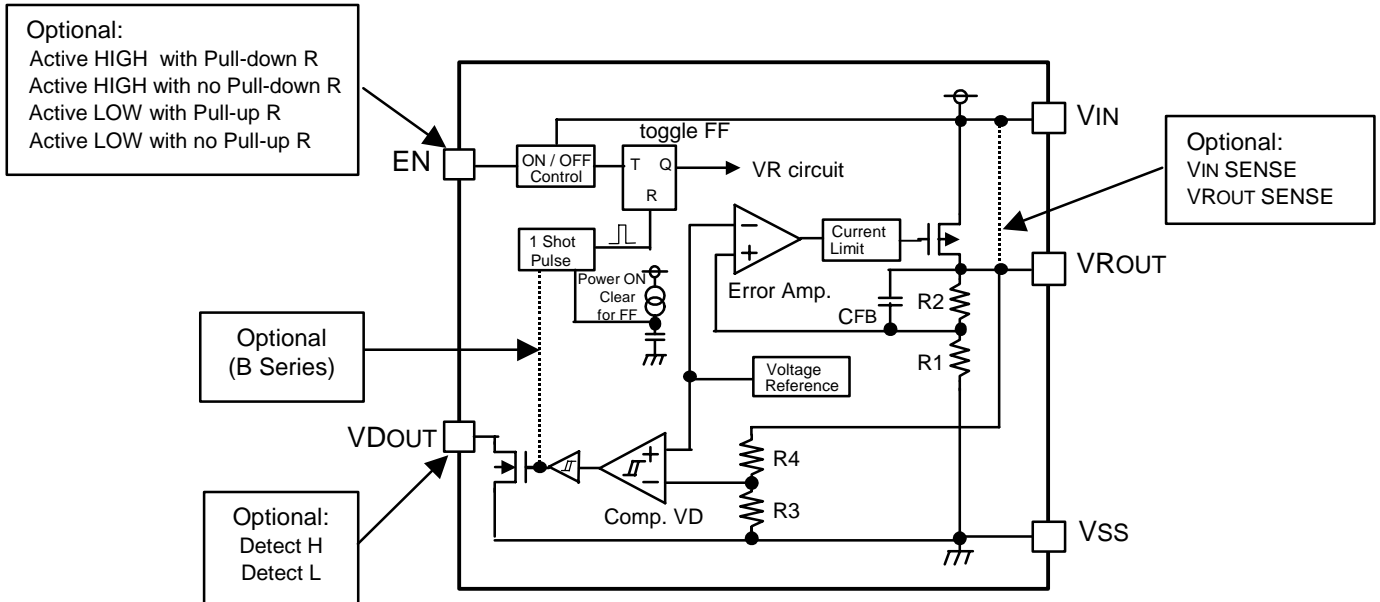

XC6403A, B Series

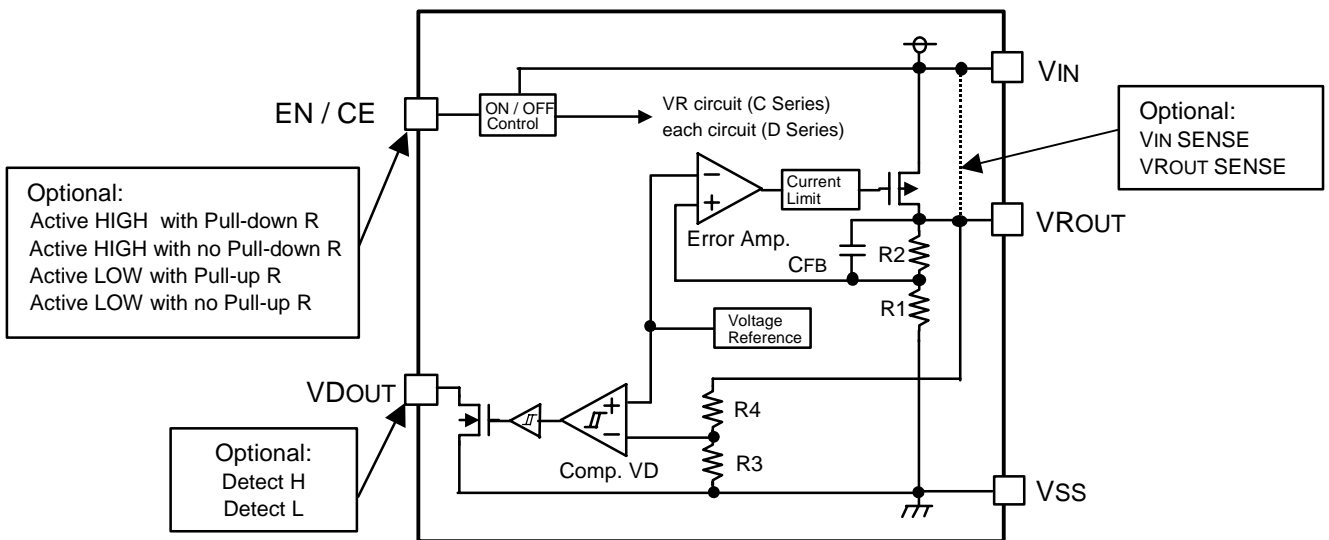

XC6403C, D Series

# XC6403 Series

High Speed LDO Regulators, Low ESR Cap. Compatible, Voltage Detector Function

## ■ BLOCK DIAGRAMS (Continued)

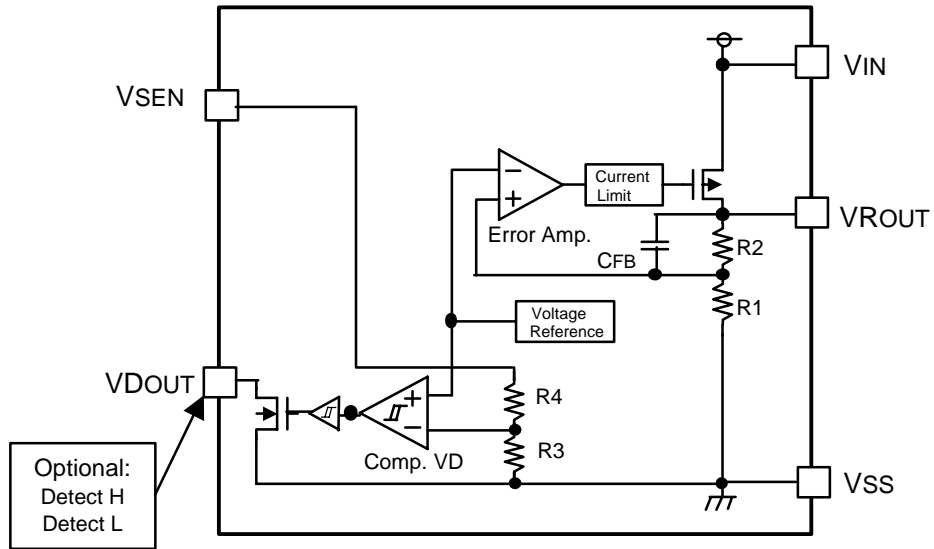

XC6403E Series

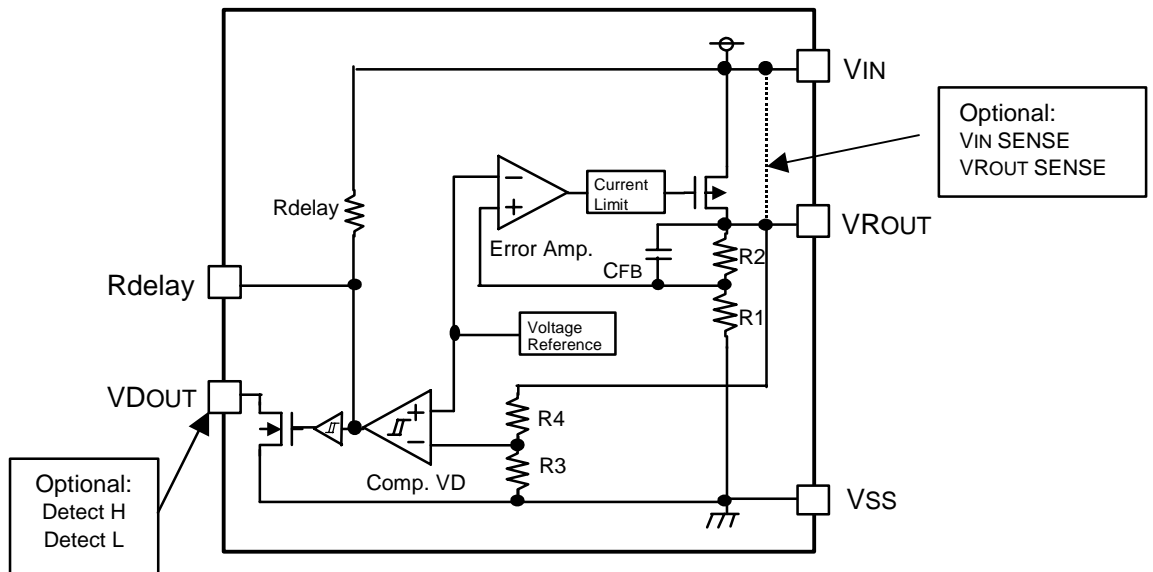

XC6403F Series

# XC6403 Series

High Speed LDO Regulators, Low ESR Cap. Compatible, Voltage Detector Function

## ■ OPERATIONAL EXPLANATION

### <Output voltage regulator control>

The voltage, divided by resistors R1 & R2 which are connected to the VROUT pin is compared with the internal reference voltage by the error amplifier. The P-Channel MOSFET, which is connected to the VROUT pin, is then driven by the subsequent output signal. The output voltage at the VROUT pin is controlled & stabilized by negative feedback.

The current limit circuit and short circuit protection operate in relation to the level of output current. Further, the voltage regulator's internal circuitry can be shutdown via the EN or CE pin's signal.

### <Detector function with the XC6403 series>

The series' detector function monitors the voltage divided by resistors R3 & R4 which are connected to the VROUT pin or the VIN pin or the VSEN pin, as well as monitoring the voltage of the internal reference voltage source via the comparator. The VDSSEN pin has options (please refer to the Selection Guide, item 4 on page 2). A 'High' or 'Low' signal level can be output from the VDOUT pin when the VD pin voltage level goes below the detect voltage. The VD output logic has options (please refer to the Selection Guide, item 5 on page 2). As VDOUT is an open-drain N-channel output, a pull-up resistor of about 220KΩ is needed to achieve a voltage output. Because of hysteresis at the detector function, output at the VDOUT pin will invert when the detect voltage level increases above the release voltage (105% of the detect voltage). Even when the XC6403A, B, C, series are in stand-by mode, the voltage detector function operates and the output voltage at VDOUT will output according to the voltage level at VDSSEN voltage.

For the XC6403A, B, C type, in stand-by, if a voltage of the recovery voltage is present at the VROUT pin (from another power source), the VDOUT pin will be high impedance mode, and the pull up voltage will be output at VDOUT. By connecting the Cdelay pin to a capacitor (Cd), the XC6403F series can apply a delay time to VDOUT voltage when releasing voltage. The delay time can be calculated from the internal resistance, Rdelay (2MΩ fixed) and the value of Cd as per the following equation.

$$\text{Delay Time} = C_{\text{delay}} \times R_{\text{delay}} \times 0.7$$

Delay Time	Rdelay standard : 1.0 ~ 3.5MΩ	TYP : 2.0MΩ
Cdelay	DELAY TIME (TYP.)	DELAY TIME (TYP.)
0.01 μF	14 msec	7.0 ~ 24.5 msec
0.022 μF	30.8 msec	15.4 ~ 53.9 msec
0.047 μF	65.8 msec	32.9 ~ 115.15 msec
0.1 μF	140 msec	70.0 ~ 245.0 msec
0.22 μF	308 msec	154.0 ~ 539.0 msec
0.47 μF	658 msec	329.0 ~ 1151.5 msec
1 μF	1400 msec	700.0 ~ 2450.0 msec

### <Low ESR Capacitors>

With the XC6403 series regulator, a stable output voltage is achievable even if low ESR capacitors are used, as a phase compensation circuit is built-in to the regulator. In order to ensure the effectiveness of the phase compensation, we suggest that an output capacitor (CL) be connected as close as possible, between the output pin (VROUT) and the VSS pin. Please use an output capacitor (CL) with a capacitance, based on the chart below. We also suggest an input capacitor (CIN) of 1μF : this should be connected between VIN and VSS in order to stabilize input power source.

### Output Capacitor

VROUT	0.9 ~ 1.2V	1.3 ~ 1.7V	1.8 ~ 5.6V
CL	more than 4.7μF	more than 2.2μF	more than 1.0μF

### <Current Limiter, Short-Circuit Protection>

The XC6403 series regulator offers a combination of current limit and circuit protection by means of a built-in fixed current limiter circuit and a foldback circuit. When the load current reaches the current limit level, the fixed current limiter circuit operates and output voltage drops. As a result of this drop in output voltage, the foldback circuit operates, the output voltage drops further and output current decreases. When the output pin is shorted, a current of about 50mA flows.



### ■ OPERATIONAL EXPLANATION (Continued)

#### <EN / CE Pin>

The IC's internal regulator circuitry can be shut down via the signal from the EN pin with the XC6403A, B, C series. In shutdown mode, output at the VROUT pin will be pulled down to the VSS level via R1 & R2. The whole IC's circuitry can be shut down via CE pin with the XC6403D series and power consumption can be reduced to around 0  $\mu$ A. While the voltage detector is in shutdown mode, the voltage detector output is in a post-detection state. When choosing Detect L, input current can be set by using the following formula.

$$\text{Input Current} = V_{IN} \text{ voltage} / \text{Pull Up Resistance}$$

In stand-by mode, the above input current can be reduced by connecting a pull-up resistor between VROUT and VDOUT.

Note that as the XC6403\*E to K types of the XC6403A to D series are 'Active HIGH / No Pull Down' and XC6403\*R to U types of the XC6403A to D series are 'Active LOW / No Pull Up', operations will become unstable with the CE pin open (See the chart below).

SERIES	CE INPUT LOGIC	(* A ~ D Series)
XC6403 * A ~ D	Active HIGH with pull down	
XC6403 * E ~ K	Active HIGH with no pull down	
XC6403 * L ~ P	Active LOW with pull up	
XC6403 * R ~ U	Active LOW with no pull up	

We suggest that you use this IC with either a VIN voltage or a VSS voltage input at the EN or CE pin. If this IC is used with the correct specifications for the EN or CE pin, the IC will operate normally. However, supply current may increase as a result of through current in the IC's internal circuitry if a voltage other than VIN or VSS is applied.

#### <Toggle Operation>

The XC6403 A and B series have a built-in toggle ON/OFF switch which repeats an on/off operation via the EN pin's leading edge signal when the EN logic is Active HIGH, and via the EN pin's falling edge signal when the EN logic is Active LOW (Please also refer the figure below). The EN input signal duration should be over 500nsec. If the EN input signal is less than 500nsec, it is possible that the circuit fails to respond and the toggle function does not operate. To operate the toggle function properly when the EN pin voltage noise is large, a RC filter should be used to reduce the noise in the signal to the EN pin. In the case where input delay time is required, it is possible to set the time constant by connecting an RC network to the EN pin.

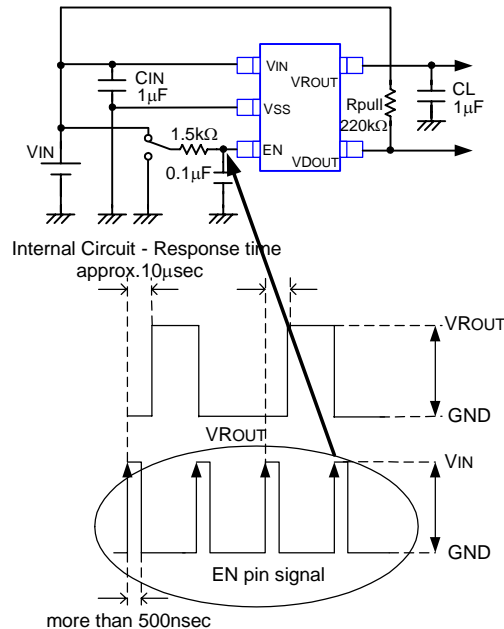

EN Logic Active "HIGH"

### ■ OPERATIONAL EXPLANATION (Continued)

<Toggle Operation> (Continued)

For the XC6403B series, there are two types of toggle selection; one is a T-type flip-flop (T-FF) used for toggle operation which can be reset internally by a signal directly from the voltage detector (VIN Sense type only. See also the Selection Guide on page 2). The other type is where the reset is applied internally through a one shot pulse circuit (VIN, VROUT type only. See also the Selection Guide on page 2).

The type, which applies the reset directly via the signal from the voltage detector function, applies the voltage detector comparator's output signal (reset signal) to the reset of T-FF reset, and turns the VR output OFF when the input voltage decreases below the detect voltage due to battery consumption, etc.. In order to return the VR output, apply a voltage larger than the release voltage to VIN and input a toggle signal to the T-FF. In the case where input voltage is below the release voltage, the VR output does not return even though the toggle signal is input into the T-FF.

The type which applies the reset signal to the T-FF internally via a one-shot pulse circuit changes the voltage detector comparator output signal to a one-shot signal internally. Like the type which applies the reset directly via the signal from voltage detector function, this type also applies the reset to the T-FF and sets the VR output to OFF when the input voltage (VIN Sense type) and output voltage (VROUT Sense type) drop below the detect voltage level. This type can return the VR output by inputting a toggle signal, even when the Sense pin voltage (VIN or VROUT pin voltage) is below the release voltage.

Please refer to the block diagram below and the timing chart on the following page. Please choose the option suitable to the application.

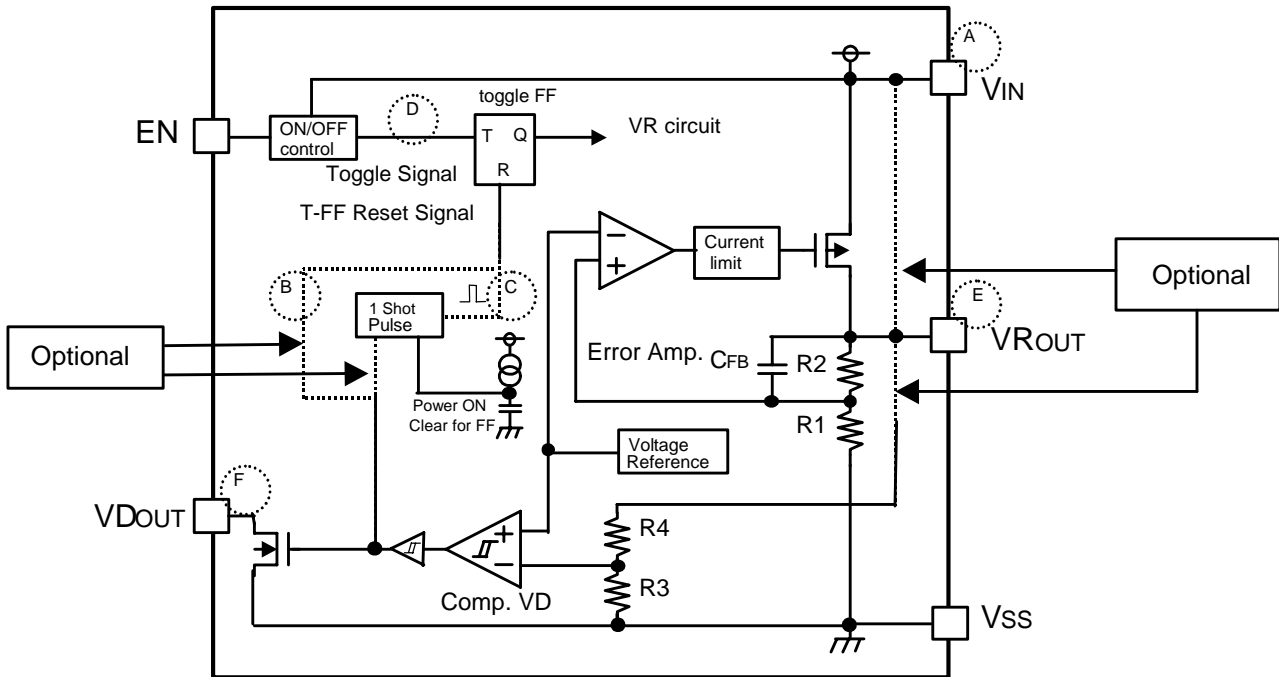

Block Diagram for XC6403B series Timing Chart

### TIMING CHART

- Using the VD output level signal as the reset signal of T-FF (VD Sense = VIN PIN)

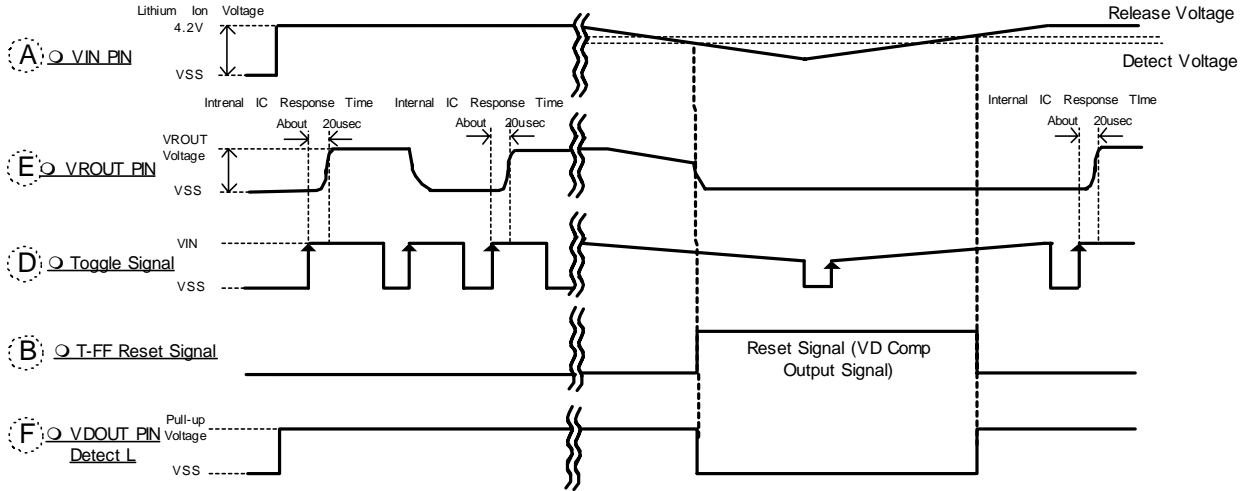

- Changing the VD output level signal into a one shot pulse to use T-FF as the reset signal (VD Sense = VIN PIN)

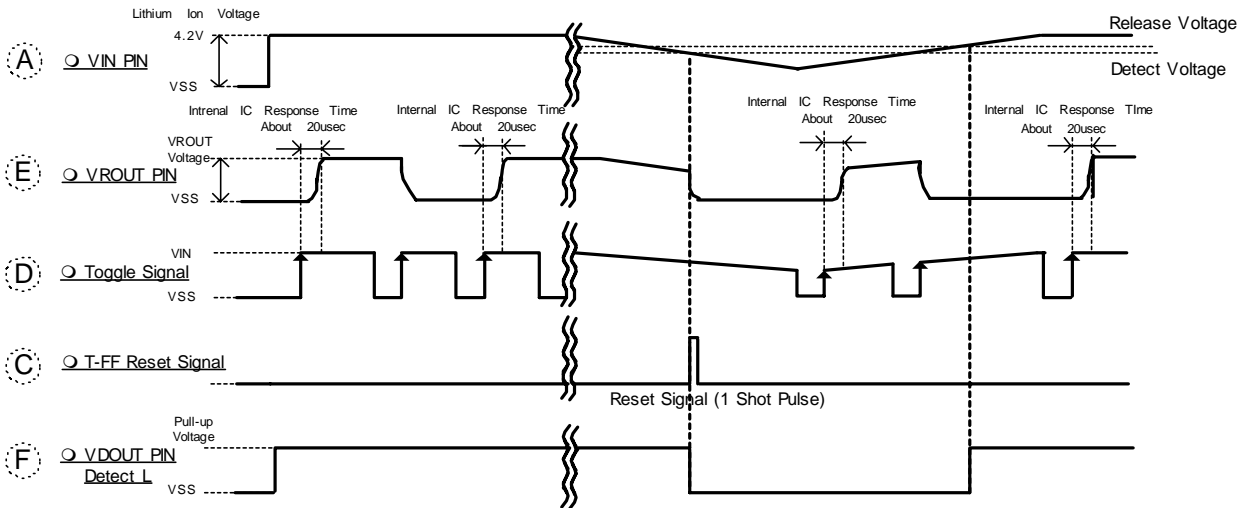

- Changing the VD output level signal into a one shot pulse to use T-FF as the reset signal (VD Sense = VROUT PIN)

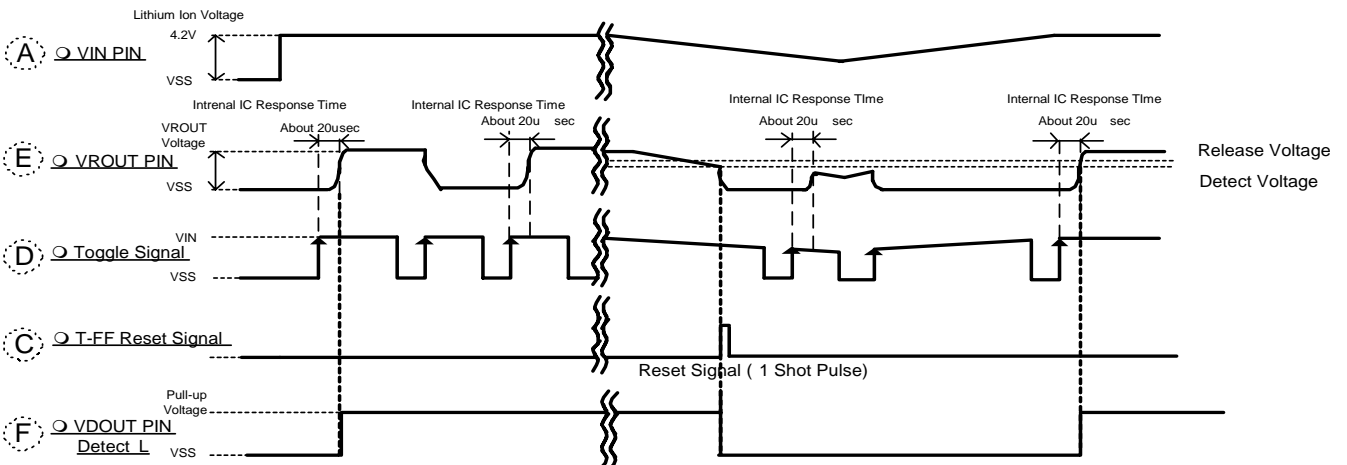

The circled letters correspond to those shown on the block diagram on page 26.

# XC6403 Series

*High Speed LDO Regulators, Low ESR Cap. Compatible, Voltage Detector Function*

## ■ NOTES ON USE

1. Please use this IC within the stated absolute maximum ratings. The IC is liable to malfunction should the ratings be exceeded.
2. Where wiring impedance is high, operations may become unstable due to noise and/or phase lag depending on output current.  
Please strengthen VIN and VSS wiring in particular.
3. Please wire the input capacitor (CIN) and the output capacitor (CL) as close to the IC as possible.  
Should rapid input fluctuation or load fluctuation occur, please increase the capacitor value such as CIN or CL to stabilize the operation.