



# Obsolescence Notice

This product is obsolete.

This information is available for your convenience only.

For more information on Zarlink's obsolete products and replacement product lists, please visit [http://products.zarlink.com/obsolete\\_products/](http://products.zarlink.com/obsolete_products/)

### Features

- Differential to single ended conversion
- No transformers required
- Minimum installation space
- Off-Hook detection and LED indicator drive
- Relay drive output
- Battery and ringing feed to line
- Logic interface:  $\overline{\text{MUTE}}$ ,  $\overline{\text{OFHK}}$ , RC
- Mute of incoming audio
- Dial pulse detection
- Voltage surge protection

### Applications

Line Interface for:

- PABX
- Intercoms
- Key Systems

### Ordering Information

MH88500IN    20 Pin SIL Package

**0°C to 70°C**

### Description

The Zarlink MH88500IN Subscriber Line Interface Circuit provides a complete interface between the telephone line and a speech switch requiring only single bidirectional switch per crosspoint. The functions provided by the MH88500IN include bidirectional differential to single ended conversion in the speech path, line battery feed, ringing feed and loop and dial pulse detection. The device is fabricated as a thick film hybrid in a 20-pin 'single-in-line' package allowing optimum circuit board packing density.

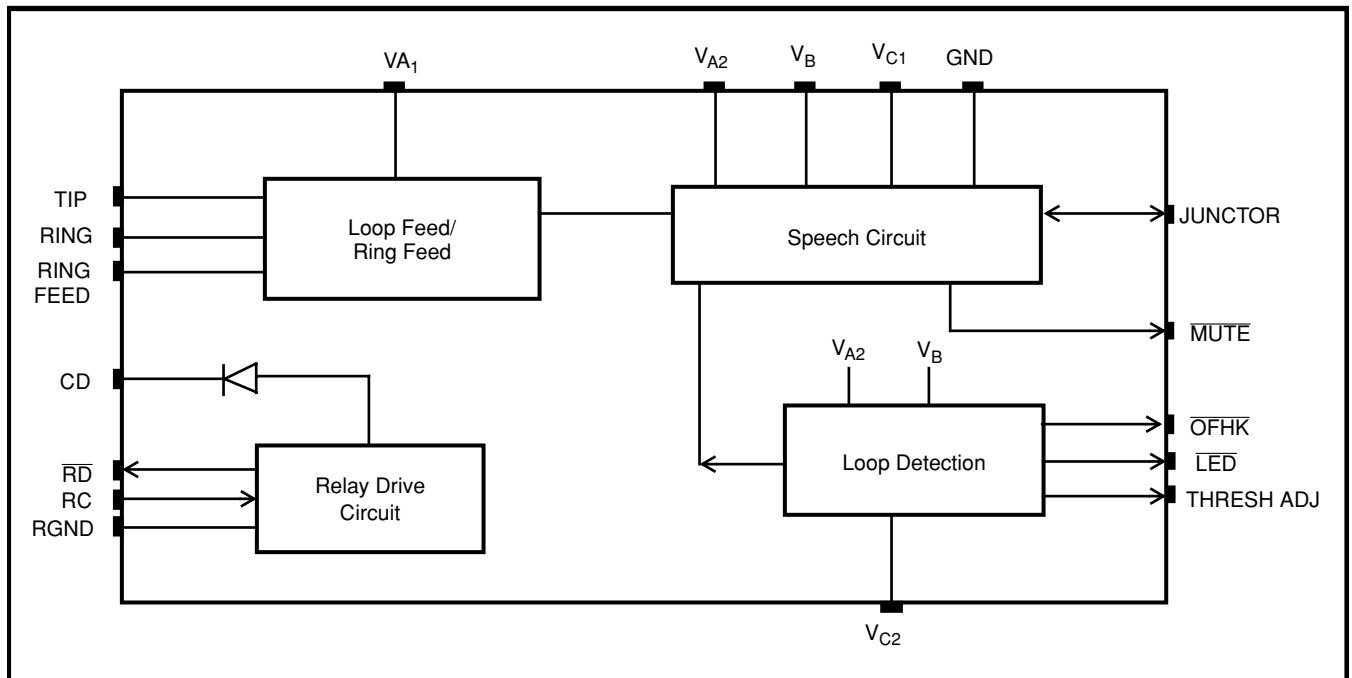

**Figure 1 - Functional Block Diagram**

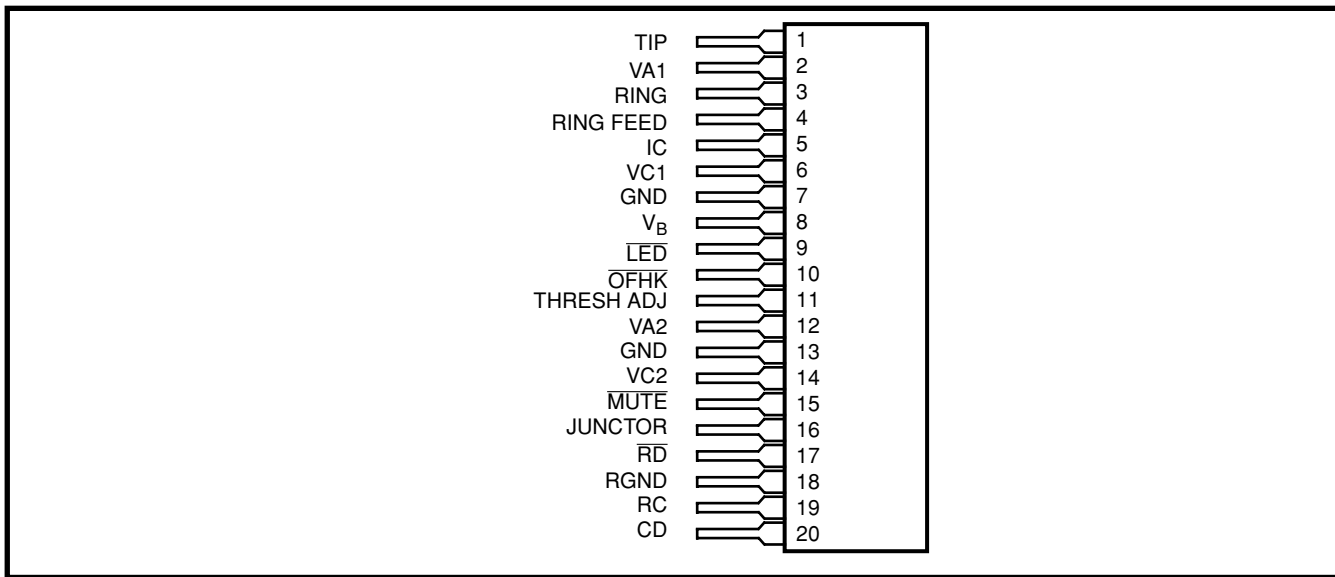

Figure 2 - Pin Connections

## Pin Description

Pin #	Name	Description
1	TIP	<b>Tip Lead.</b> Connects to the “Tip” lead (A-wire) of the telephone line.
2	V <sub>A1</sub>	<b>Positive Line Feed Supply Voltage.</b> Normally connected to V <sub>A2</sub> .
3	RING	<b>Ring Lead.</b> Connects to the “Ring” lead (B-wire) of the telephone line.
4	RING FEED	<b>Negative Line Feed Voltage and Ringing Input.</b> Normally connected to Ring Relay.
5	IC	<b>Internal Connection.</b> Leave open circuit. Use for testing only.
6	V <sub>C1</sub>	<b>Sense Input.</b> Normally connected to negative line feed voltage supply.
7	GND	<b>Analog ground (0V).</b> Internally connected to pin 13.
8	V <sub>B</sub>	<b>Negative Analog Supply Voltage.</b>
9	LED	<b>LED Drive Output.</b> Drives an LED directly. Off-Hook condition, logic low.
10	OFHK	<b>Logic Low Output.</b> Indicates closed loop condition (Off-Hook and dial pulsing).
11	THRESH ADJ	Allows adjustment of OFHK detection threshold.
12	V <sub>A2</sub>	<b>Positive Power Supply Voltage.</b> Normally connected to V <sub>A1</sub> .
13	GND	<b>Analog Ground (0V).</b> Internally connected to pin 7.
14	V <sub>C2</sub>	<b>Loop Detector Voltage Supply.</b> Connected to negative line feed voltages supply.
15	MUTE	Input mutes the incoming audio. Active low.
16	JUNCTOR	<b>Receive/transmit audio speech path.</b> (referenced to 0V GND)
17	RD	<b>Relay Drive Output.</b> Open collector sinks current when RC high. Diode clamp protected.
18	RGND	<b>Ground for Relay Drive Circuit.</b>
19	RC	<b>Ring Control Input.</b> Active high.
20	CD	<b>Clamping Diode.</b> Normally connected to relay positive voltage.

## Functional Description

### Speech Circuit

The speech circuit converts the bidirectional TIP and RING line pair to a bidirectional single ended junctor line. Figure 3 illustrates a typical connection between two SLIC's through two crosspoint switches. This configuration gives optimum transhybrid loss as seen from Figure 4 given that the output impedance of the Junctor line is 604Ω.

The  $\overline{\text{MUTE}}$  input mutes signals coming from TIP and RING to the junctor line while allowing the signal from the junctor to the tip-ring pair to be transmitted.

### Loop Detection

The loop detection circuit determines whether a low enough impedances is across TIP and RING to be recognized as an off-hook condition.

(Threshold impedance = 5.4kΩ with no adjustment)  
 This threshold level can be adjusted by the use of external resistors as shown in Figure 6.  $\overline{\text{OFHK}}$  has low output drive capability so it may drive CMOS operating with different power supplies.

### Line Feed/Ring Feed Circuit

The line feed circuit provides loop current and the ability to apply ringing onto TIP and RING. The impedance from RING FEED to GND is 600Ω which gives the loop current as:

$$I_L = \frac{\text{Voltage at RING FEED pin}}{\text{Telephone Impedance} + 600} \quad \text{Amps}$$

The positive supply for the line feed circuit is  $V_{A1}$  through the loop current is determined from RING FEED and GND.

### Relay Drive Circuit

The relay drive circuit switches ringing onto RING FEED (Fig.7). The diode is present to suppress voltage transients during relay switches caused by the inductive coils of the relay. Ringing voltage includes AC ringing (90V typically) an dDC line feed voltage (-24V typically).

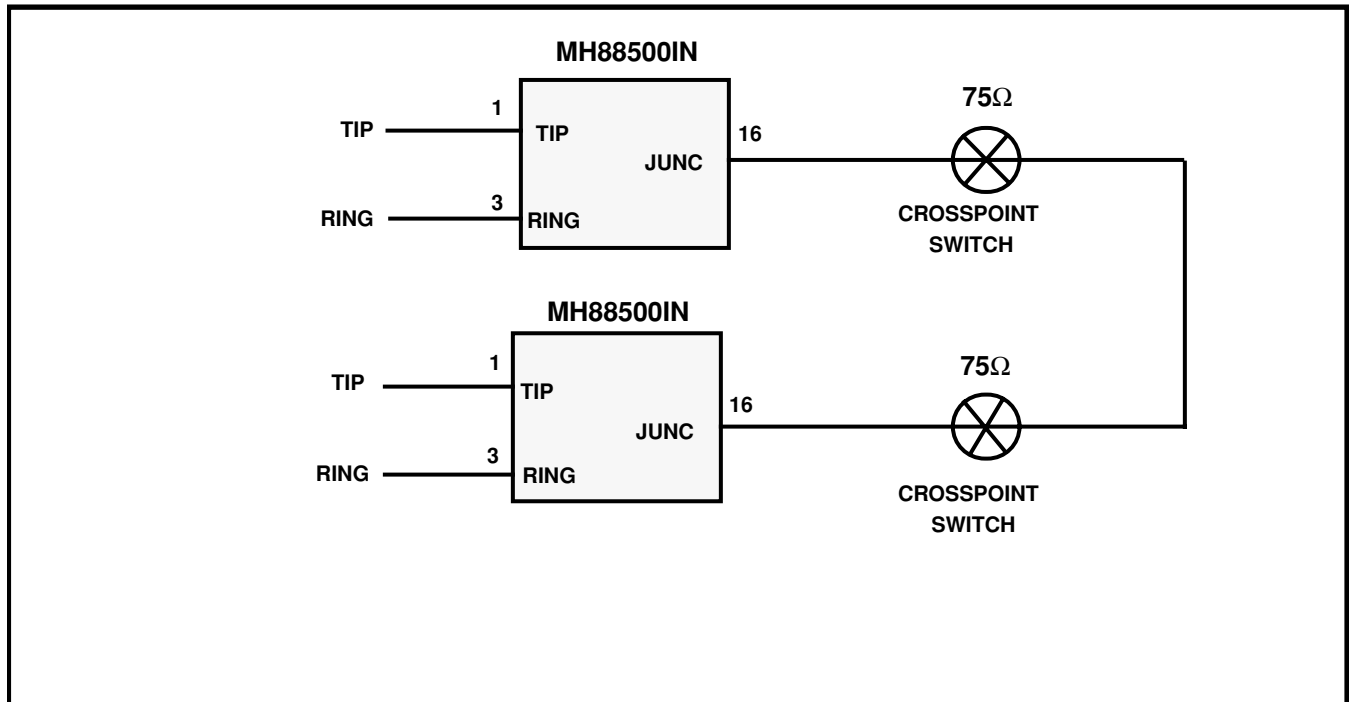

Figure 3 - SLIC Crosspoint Switch Connection

## Absolute Maximum Ratings†

	Parameter	Symbol	Min	Max	Units
1	Voltage Supplies - $V_{Ref}$ to GND	$V_{A1}, V_{A2}$			V
		$V_B$	-18	+18	V
		$V_{C1}, V_{C2}$	-35		V
2	Clamp Diode Breakdown Voltage- $V_{Ref}$ to RGND	$V_{CD}$		+15	V
3	Operating Temperature	$T_{AMB}$	0	+70	°C
4	Storage Temperature	$T_{STG}$	-40	+100	°C
5	Power Dissipation	$P_D$		1.2	Watt

† Exceeding these values may cause permanent damage. Functional operation under these conditions is not implied.

## AC Electrical Characteristics†

Voltages are with respect to ground ( $V_{SS}$ ),  $T_A = 25^\circ\text{C}$ , unless otherwise stated.  
 Test conditions unless noted,  $V_{A1}=V_{A2}=+7\text{V}$ ,  $V_B=8\text{V}$ ,  $V_{C2}=-24\text{V}(\pm 5\%)$ .

	Characteristics	Sym	Min	Typ†	Max	Units	Test Conditions	
1	Junctor to differential output (tip-ring) gain.	$A_{JL}$	0.8	1.0 0	1.2	V/V dB	1kHz, 400mV <sub>RMS</sub> source on pin 16. Note 2	
2	Differential Input (tip-ring) to junctor gain	$A_{LJ}$	0.8	1.0 0	1.2	V/V dB	1kHz, 1V <sub>RMS</sub> Source on pins 1&3. Note 1,2	
3	On/Off Hook Detection Threshold	Loop Resist	$R_{Thresh}$	4.0	5.4	6.0	kΩ	Note 1
		Loop Current	$I_{Thresh}$	3.6	4.0	5.3	mA	Note 1
4	Trans Hybrid Loss			55		dB	Notes 1,2. See Figure 2	
5	Passband Linearity			±1		dB	Notes 1,2	
6	Power Supply Rejection Ratio (VC to Junctor)	PSRR		40		dB	Notes 1,2	
7	Common Mode Rejection Ratio (Tip and Ring to Junctor)	CMRR		40		dB	Notes 1,2	
8	Low Frequency Cutoff (3dB)	Junctor to Line	$F_{LLJ}$	53		Hz	Notes 1,2	
		Line to Junctor	$F_{LJL}$	20		Hz	Notes 1,2	
9	High Frequency Cutoff (3dB)	Line to Junctor	$F_{HLJ}$	800		kHz	Notes 1,2	
		Junctor to Line	$F_{HJL}$	500		kHz	Notes 1,2	
10	Longitudinal Balance			65		dB	Note 1	
11	Tip (or Ring) to ground AC input impedance	$Z_I$		300		Ω		
12	Junctor output impedance	$Z_{OJ}$		604		Ω		

† Exceeding these values may cause permanent damage. Functional operation under these conditions is not implied.

‡ Typical figures are at 25°C with nominal ±5V supplies and are for design aid only; not guaranteed and not subject to production testing.

Note 1: 754Ω connected between JUNCTOR (pin 16) and 0V.

Note 2: 604Ω connected between TIP (pin 1) and RING (pin 3).

**DC Electrical Characteristics**

		Characteristics	Sym	Min	Typ <sup>‡</sup>	Max	Units	Test Conditions
1	SUPPLY	Operating Supply Voltages	$V_{A1}, V_{A2}$ $V_B$ $V_{C1}, V_{A2}$	-13 -30	-24	+13 -20	V V V	
2		Operating Supply Currents	$I_{A1}$ $I_{A2}$ $I_B$ $I_{C1}$ $I_{C2}$		7 8 6 .2 .1		mA mA mA mA mA	
3	INPUTS	High Level Input Voltage MUTE RC	$V_{IH}$ $V_{IH}$	4.2 3			V V	
4		Low Level Input Voltage MUTE RC	$V_{IL}$ $V_{IL}$	.8 1			V	
5		High Level Input Current MUTE RC	$I_{IH}$ $I_{IH}$	-28 700			$\mu$ A $\mu$ A	
6		Low Level Input Current MUTE RC	$I_{IL}$ $I_{IL}$	100 1			$\mu$ A $\mu$ A	
7	OUTPUTS	Sink Current LED RD	$I_{LED}$ $I_{RD}$	2 65	6 100		mA mA	$V_{OFFHK} = -6V$ $CD=RC=5V, RGD=0V$ $V_{RRD} < 1.5V$
8		Diode Clamp Current	$I_{RLY}$	65	100		mA	$RC=RGND=0V,$ $CD=5V V_{RRD} < 1.5V$
9		High Level Output Voltage	$V_{OH}$	6			V	$\overline{LED}$ Unconnected
10		Low Level Output Voltage OFFHK	$V_{OL}$	-6.5			V	$\overline{LED}$ Unconnected
11		High Level Output Current	$I_{OH}$	10			$\mu$ A	
12		Low Level Output Current	$I_{OL}$	10			$\mu$ A	

‡ Typical figures are at 25°C with nominal ± 5V supplies and are for design aid only: not guaranteed and not subject to production testing.

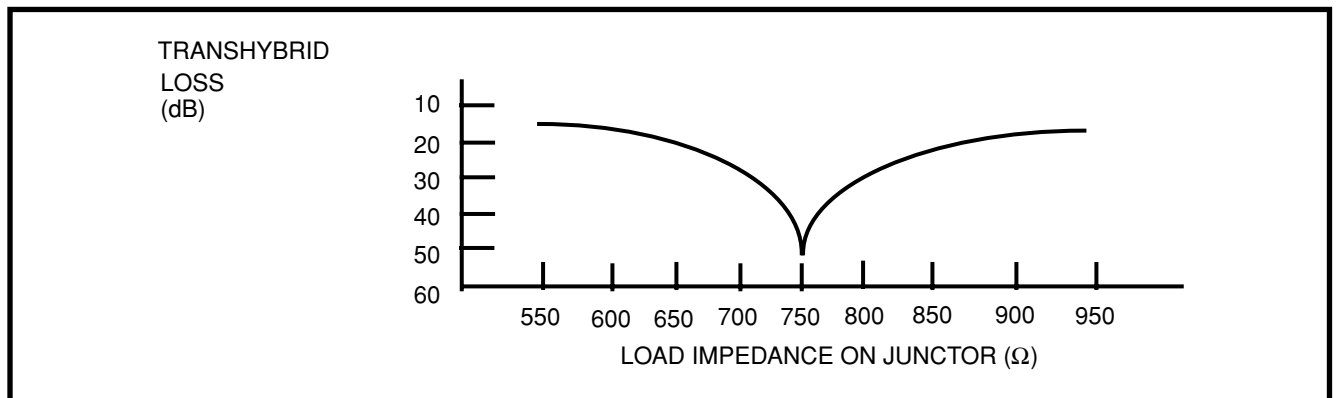

**Figure 4 - Return Loss VS Junctor Load Impedance**

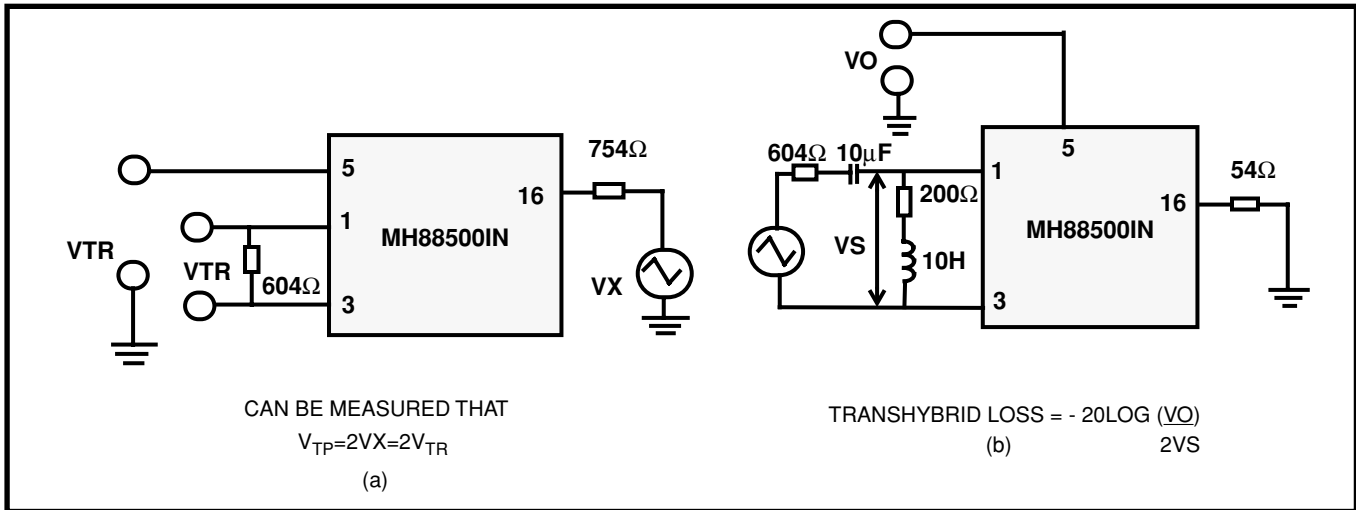

Figure 5 - Transhybrid Loss Test Circuit

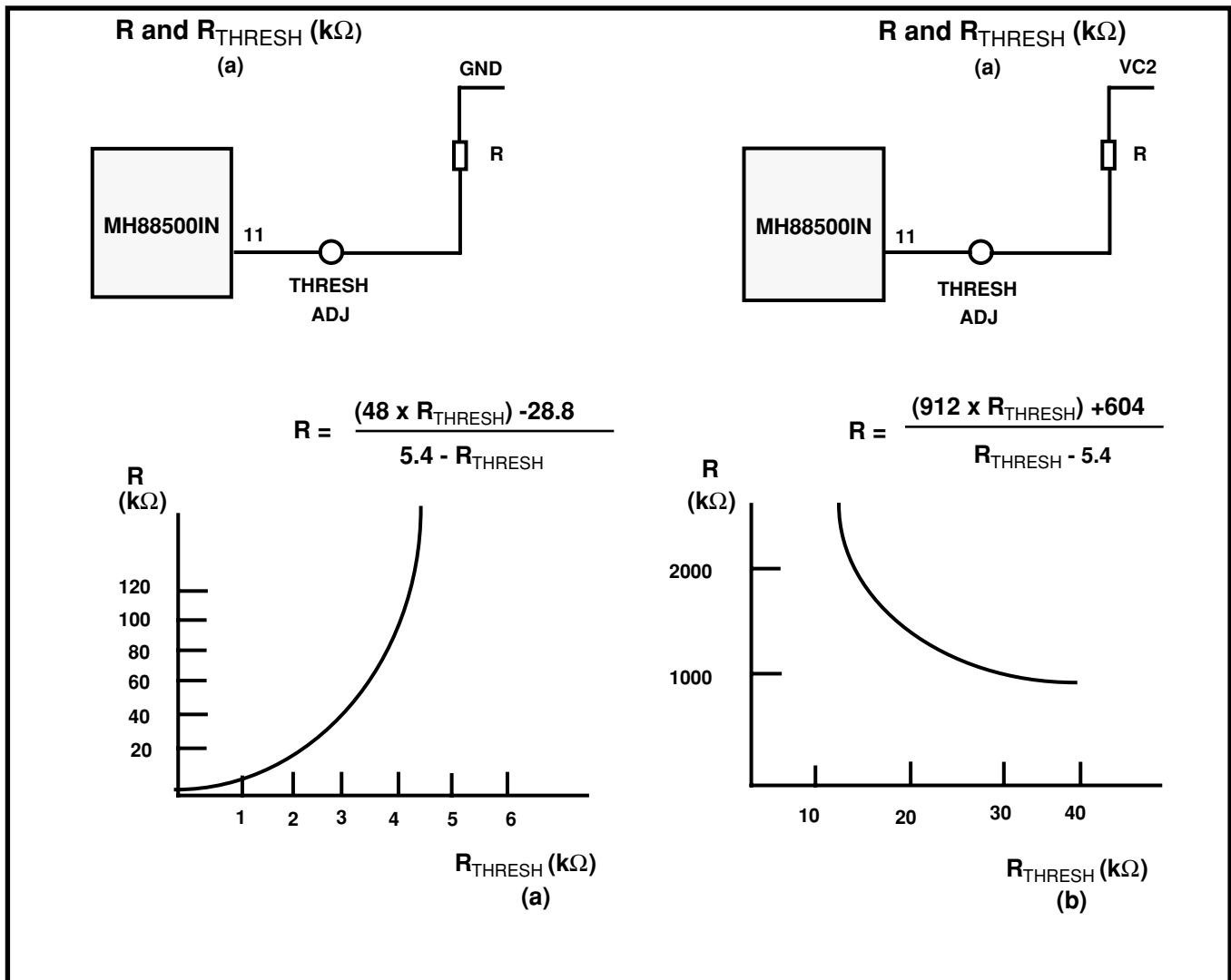

Figure 6 - Off-Hook Threshold Adjust

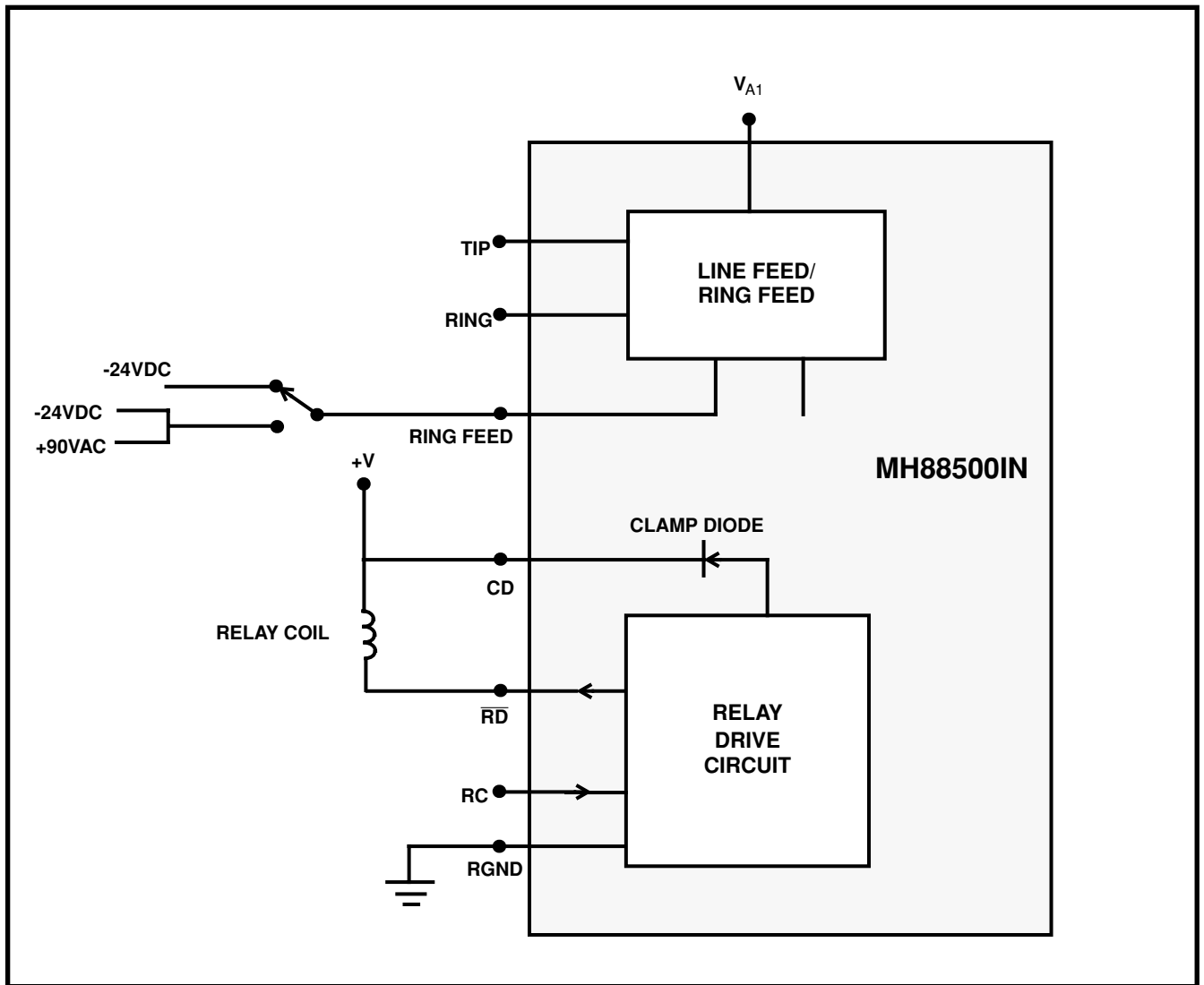
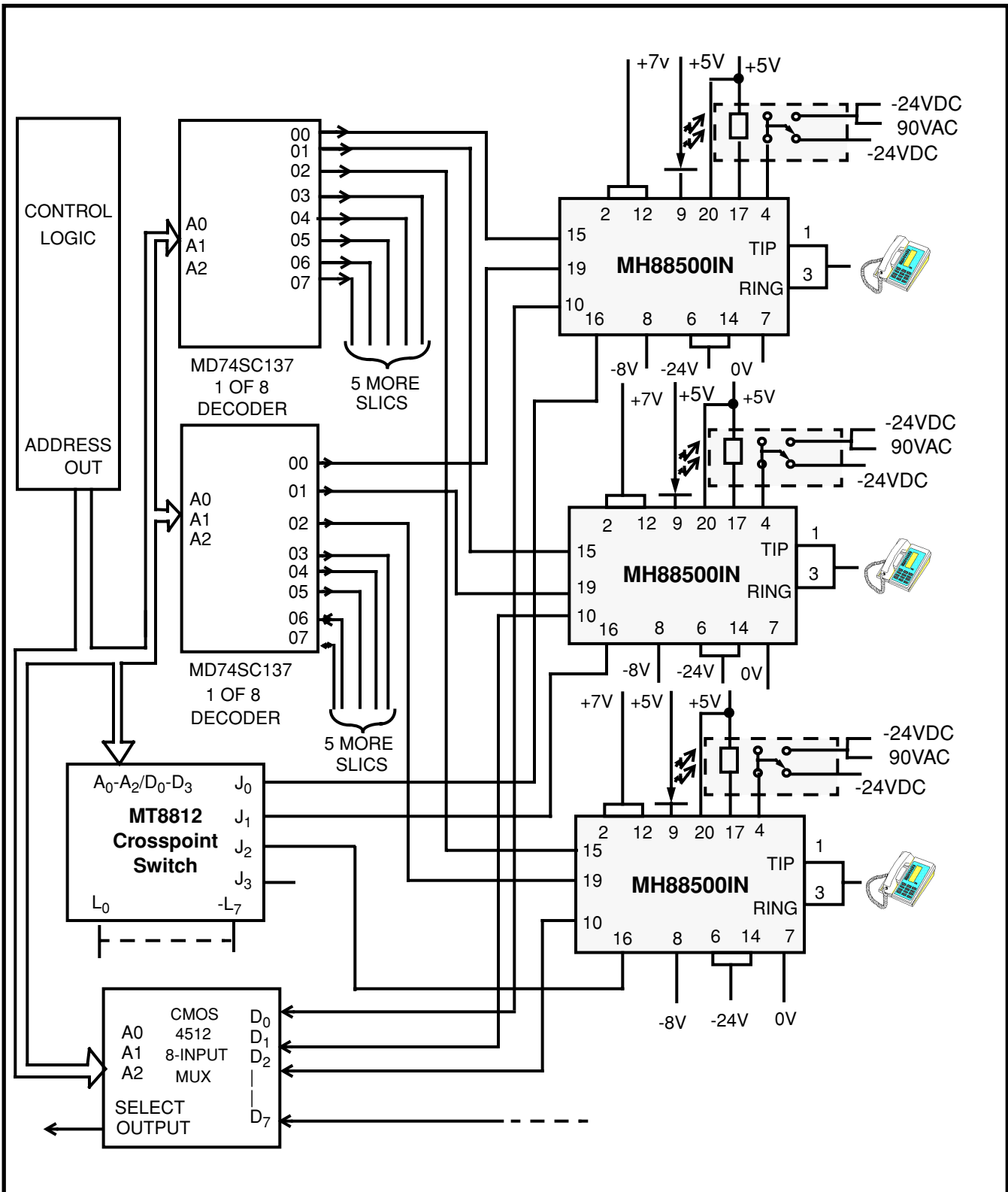
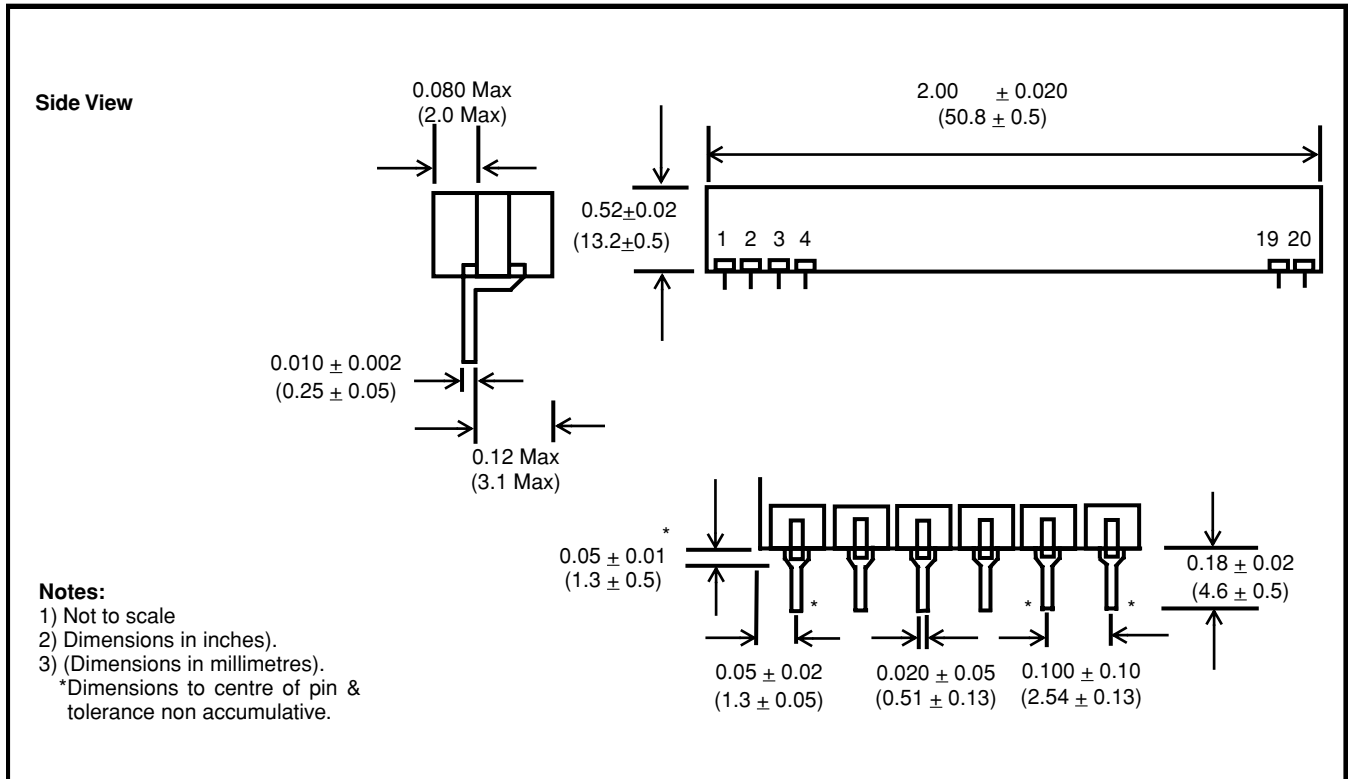

Figure 7 - Relay Drive Circuit





**Figure 8 - PABX Typical Application**



**Figure 9 -Mechanical Data**

Notes:



**For more information about all Zarlink products  
visit our Web Site at  
[www.zarlink.com](http://www.zarlink.com)**

Information relating to products and services furnished herein by Zarlink Semiconductor Inc. or its subsidiaries (collectively "Zarlink") is believed to be reliable. However, Zarlink assumes no liability for errors that may appear in this publication, or for liability otherwise arising from the application or use of any such information, product or service or for any infringement of patents or other intellectual property rights owned by third parties which may result from such application or use. Neither the supply of such information or purchase of product or service conveys any license, either express or implied, under patents or other intellectual property rights owned by Zarlink or licensed from third parties by Zarlink, whatsoever. Purchasers of products are also hereby notified that the use of product in certain ways or in combination with Zarlink, or non-Zarlink furnished goods or services may infringe patents or other intellectual property rights owned by Zarlink.

This publication is issued to provide information only and (unless agreed by Zarlink in writing) may not be used, applied or reproduced for any purpose nor form part of any order or contract nor to be regarded as a representation relating to the products or services concerned. The products, their specifications, services and other information appearing in this publication are subject to change by Zarlink without notice. No warranty or guarantee express or implied is made regarding the capability, performance or suitability of any product or service. Information concerning possible methods of use is provided as a guide only and does not constitute any guarantee that such methods of use will be satisfactory in a specific piece of equipment. It is the user's responsibility to fully determine the performance and suitability of any equipment using such information and to ensure that any publication or data used is up to date and has not been superseded. Manufacturing does not necessarily include testing of all functions or parameters. These products are not suitable for use in any medical products whose failure to perform may result in significant injury or death to the user. All products and materials are sold and services provided subject to Zarlink's conditions of sale which are available on request.

Purchase of Zarlink's I<sup>2</sup>C components conveys a licence under the Philips I<sup>2</sup>C Patent rights to use these components in and I<sup>2</sup>C System, provided that the system conforms to the I<sup>2</sup>C Standard Specification as defined by Philips.

Zarlink, ZL and the Zarlink Semiconductor logo are trademarks of Zarlink Semiconductor Inc.

Copyright Zarlink Semiconductor Inc. All Rights Reserved.

**TECHNICAL DOCUMENTATION - NOT FOR RESALE**

---