

NEC

User's Manual

IE-78K4-R-EX3

Emulation Probe Conversion Board

Target Devices
78K/IV Series

Document No. U16346EJ1V0UM00 (1st edition)
Date Published October 2002 N CP(K)

© NEC Corporation 2002
Printed in Japan

[MEMO]

Windows is either a registered trademark or a trademark of Microsoft Corporation in the United States and/or other countries.

PC/AT is a trademark of International Business Machines Corporation.

- **The information in this document is current as of August, 2002. The information is subject to change without notice. For actual design-in, refer to the latest publications of NEC's data sheets or data books, etc., for the most up-to-date specifications of NEC semiconductor products. Not all products and/or types are available in every country. Please check with an NEC sales representative for availability and additional information.**

- No part of this document may be copied or reproduced in any form or by any means without prior written consent of NEC. NEC assumes no responsibility for any errors that may appear in this document.

- NEC does not assume any liability for infringement of patents, copyrights or other intellectual property rights of third parties by or arising from the use of NEC semiconductor products listed in this document or any other liability arising from the use of such products. No license, express, implied or otherwise, is granted under any patents, copyrights or other intellectual property rights of NEC or others.

- Descriptions of circuits, software and other related information in this document are provided for illustrative purposes in semiconductor product operation and application examples. The incorporation of these circuits, software and information in the design of customer's equipment shall be done under the full responsibility of customer. NEC assumes no responsibility for any losses incurred by customers or third parties arising from the use of these circuits, software and information.

- While NEC endeavours to enhance the quality, reliability and safety of NEC semiconductor products, customers agree and acknowledge that the possibility of defects thereof cannot be eliminated entirely. To minimize risks of damage to property or injury (including death) to persons arising from defects in NEC semiconductor products, customers must incorporate sufficient safety measures in their design, such as redundancy, fire-containment, and anti-failure features.

- NEC semiconductor products are classified into the following three quality grades: "Standard", "Special" and "Specific". The "Specific" quality grade applies only to semiconductor products developed based on a customer-designated "quality assurance program" for a specific application. The recommended applications of a semiconductor product depend on its quality grade, as indicated below. Customers must check the quality grade of each semiconductor product before using it in a particular application.

"Standard": Computers, office equipment, communications equipment, test and measurement equipment, audio and visual equipment, home electronic appliances, machine tools, personal electronic equipment and industrial robots

"Special": Transportation equipment (automobiles, trains, ships, etc.), traffic control systems, anti-disaster systems, anti-crime systems, safety equipment and medical equipment (not specifically designed for life support)

"Specific": Aircraft, aerospace equipment, submersible repeaters, nuclear reactor control systems, life support systems and medical equipment for life support, etc.

The quality grade of NEC semiconductor products is "Standard" unless otherwise expressly specified in NEC's data sheets or data books, etc. If customers wish to use NEC semiconductor products in applications not intended by NEC, they must contact an NEC sales representative in advance to determine NEC's willingness to support a given application.

(Note)

(1) "NEC" as used in this statement means NEC Corporation and also includes its majority-owned subsidiaries.

(2) "NEC semiconductor products" means any semiconductor product developed or manufactured by or for NEC (as defined above).

M8E 00.4

Regional Information

Some information contained in this document may vary from country to country. Before using any NEC product in your application, please contact the NEC office in your country to obtain a list of authorized representatives and distributors. They will verify:

- Device availability
- Ordering information
- Product release schedule
- Availability of related technical literature
- Development environment specifications (for example, specifications for third-party tools and components, host computers, power plugs, AC supply voltages, and so forth)
- Network requirements

In addition, trademarks, registered trademarks, export restrictions, and other legal issues may also vary from country to country.

NEC Electronics Inc. (U.S.)

Santa Clara, California
Tel: 408-588-6000
800-366-9782
Fax: 408-588-6130
800-729-9288

NEC do Brasil S.A.

Electron Devices Division
Guarulhos-SP, Brasil
Tel: 11-6462-6810
Fax: 11-6462-6829

NEC Electronics (Europe) GmbH

Duesseldorf, Germany
Tel: 0211-65 03 01
Fax: 0211-65 03 327

• Sucursal en España

Madrid, Spain
Tel: 091-504 27 87
Fax: 091-504 28 60

• Succursale Française

Vélizy-Villacoublay, France
Tel: 01-30-67 58 00
Fax: 01-30-67 58 99

• Filiale Italiana

Milano, Italy
Tel: 02-66 75 41
Fax: 02-66 75 42 99

• Branch The Netherlands

Eindhoven, The Netherlands
Tel: 040-244 58 45
Fax: 040-244 45 80

• Branch Sweden

Taeby, Sweden
Tel: 08-63 80 820
Fax: 08-63 80 388

• United Kingdom Branch

Milton Keynes, UK
Tel: 01908-691-133
Fax: 01908-670-290

NEC Electronics Hong Kong Ltd.

Hong Kong
Tel: 2886-9318
Fax: 2886-9022/9044

NEC Electronics Hong Kong Ltd.

Seoul Branch
Seoul, Korea
Tel: 02-528-0303
Fax: 02-528-4411

NEC Electronics Shanghai, Ltd.

Shanghai, P.R. China
Tel: 021-6841-1138
Fax: 021-6841-1137

NEC Electronics Taiwan Ltd.

Taipei, Taiwan
Tel: 02-2719-2377
Fax: 02-2719-5951

NEC Electronics Singapore Pte. Ltd.

Novena Square, Singapore
Tel: 253-8311
Fax: 250-3583

INTRODUCTION

Product Overview

The IE-78K4-R-EX3 is designed to be used with an in-circuit emulator (IE-784000-R), emulation board (IE-784000-R-EM), and I/O emulation board (IE-784xxx-NS-EM1) to debug 78K/IV Series 16-bit single-chip microcontrollers.

Target Readers

This manual is intended for engineers who will use an in-circuit emulator (IE-784000-R), emulation board (IE-784000-R-EM), and I/O emulation board (IE-784xxx-NS-EM1) with the IE-78K4-R-EX3 to perform system debugging.

Engineers who use this manual are expected to be thoroughly familiar with the target device's functions and usage methods and to be knowledgeable about debugging.

Organization

When using the IE-78K4-R-EX3, refer to not only this manual (supplied with the IE-78K4-R-EX3) but also the manuals that are supplied with the in-circuit emulator (IE-784000-R) and the I/O emulation board (IE-784xxx-NS-EM1).

IE-784000-R
User's Manual

- Basic specifications
- System configuration
- External interface functions

IE-784xxx-NS-EM1
User's Manual

- General
- Part names
- Installation
- Differences between target devices and target interface circuits

IE-78K4-R-EX3
User's Manual

- General
- Part names
- Installation

Purpose

This manual's purpose is to explain various debugging functions that can be performed when using the IE-78K4-R-EX3.

Terminology

The meanings of certain terms used in this manual are listed below.

Term	Meaning
Target device	This is the device that is the target for emulation.
Target system	This includes the target program and the hardware provided by the user. When defined narrowly, it includes only the hardware.
IE system	This refers to the combination of an in-circuit emulator (IE-784000-R), emulation probe conversion board (IE-78K4-R-EX3), emulation board (IE-784000-R-EM), and I/O emulation board (IE-784xxx-NS-EM1).

Conventions

Data significance: Higher digits on the left and lower digits on the right

Note: Footnote for item marked with **Note** in the text

Caution: Information requiring particular attention

Remark: Supplementary information

Related Documents

The related documents (user's manuals) indicated in this publication may include preliminary versions. However, preliminary versions are not marked as such.

Document Name	Document No.
IE-784000-R In-Circuit Emulator	U12903E
IE-78K4-R-EX3 Emulation Probe Conversion Board	This manual
ID78K Series Integrated Debugger Ver. 2.30 or Later Operation (Windows™ Based)	U15185E

Caution The related documents listed above are subject to change without notice. Be sure to use the latest version of each document for designing.

CONTENTS

CHAPTER 1 GENERAL	10
1.1 System Configuration.....	11
1.2 Hardware Configuration.....	13
CHAPTER 2 PART NAMES	14
2.1 Parts of Main Unit	15
CHAPTER 3 INSTALLATION	16
3.1 Installation Procedure	17
CHAPTER 4 CAUTIONS	20
APPENDIX A EMULATION PROBE PIN ASSIGNMENT TABLE	21

LIST OF FIGURES

Figure No.	Title	Page
1-1	System Configuration	11
1-2	Basic Hardware Configuration	13
2-1	Side Connected to IE-784000-R-EM and IE-784xxx-NS-EM1	15
3-1	Connection Outline of IE-78K4-R-EX3.....	17
3-2	Connecting IE-78K4-R-EX3 and IE-784xxx-NS-EM1	18
3-3	Connecting IE-784000-R-EM and IE-78K4-R-EX3 + IE-784xxx-NS-EM1	18
3-4	Removing Top Cover.....	19
3-5	Inserting in IE-784000-R.....	19

LIST OF TABLES

Table No.	Title	Page
1-1	Package Correspondence Table	12
A-1	Emulation Probe Pin Assignment Table	21

CHAPTER 1 GENERAL

The IE-78K4-R-EX3 is a development tool for efficient debugging of hardware or software when using a 78K/IV Series 16-bit single-chip microcontroller.

This chapter describes the IE-78K4-R-EX3 system configuration and hardware configuration.

1.1 System Configuration

Figure 1-1 illustrates the IE-78K4-R-EX3 system configuration.

Figure 1-1. System Configuration

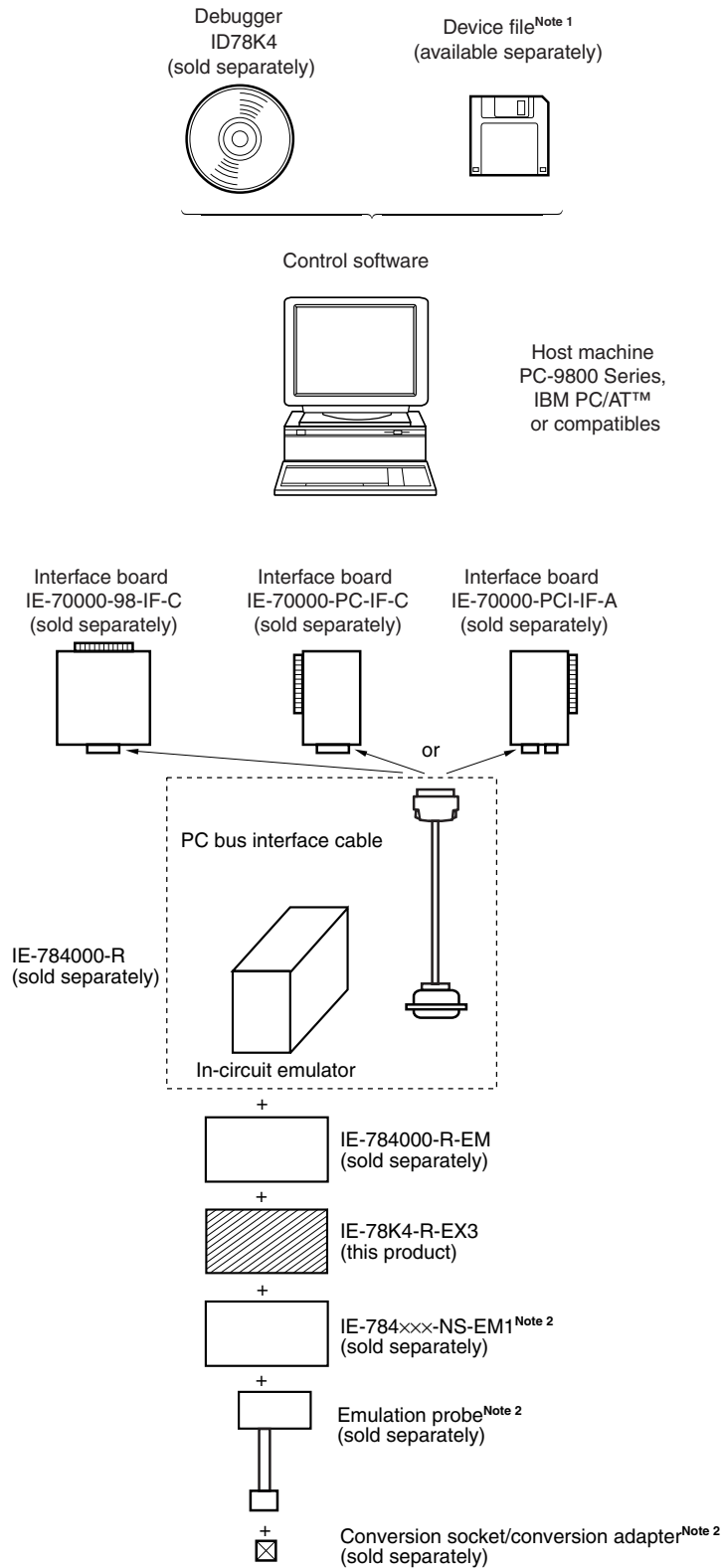

- Notes**
1. For the device file, refer to the IE-784xxx-NS-EM1 User's Manual.
 2. For the IE-784xxx-NS-EM1, emulation probe, and conversion socket/conversion adapter, refer to Table 1-1. The TGC-100SDW and NQPACK100RB are products of TOKYO ELETECH CORPORATION.

Inquiries: Daimaru Kogyo, Co., Ltd.

Tokyo Electronics Department (TEL: +81-3-3820-7112)

Osaka Electronics Department (TEL: +81-6-6244-6672)

Table 1-1. Package Correspondence Table

Package	I/O Emulation Board	Emulation Probe	Conversion Socket/ Conversion Adapter
100-pin LQFP	IE-784225-NS-EM1	EP-78064GC-R	TGC-100SDW
100-pin QFP		EP-784218GF-R	EV-9200GF-100
	IE-784928-NS-EM1	EP-784915GF-R	EV-9200GF-100
			NQPACK100RB
IE-784937-NS-EM1	EP-78064GF-R	EV-9200GF-100	

1.2 Hardware Configuration

Figure 1-2 shows the IE-78K4-R-EX3's position in the basic hardware configuration.

Figure 1-2. Basic Hardware Configuration

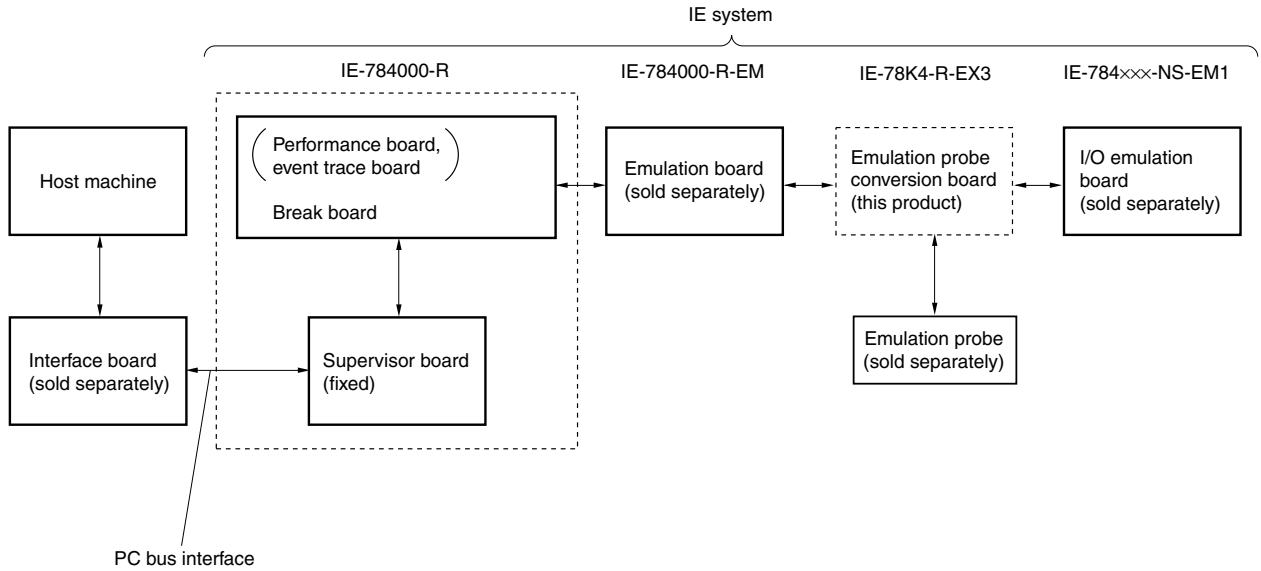

CHAPTER 2 PART NAMES

This chapter introduces the parts of the IE-78K4-R-EX3 main unit.

The packing box contains the emulation probe conversion board (IE-78K4-R-EX3), packing list, user's manual, and guarantee card.

If there are any missing or damaged items, please contact an NEC sales representative.

Fill out and return the guarantee card that comes with the main unit.

2.1 Parts of Main Unit

Figure 2-1. Side Connected to IE-784000-R-EM and IE-784xxx-NS-EM1

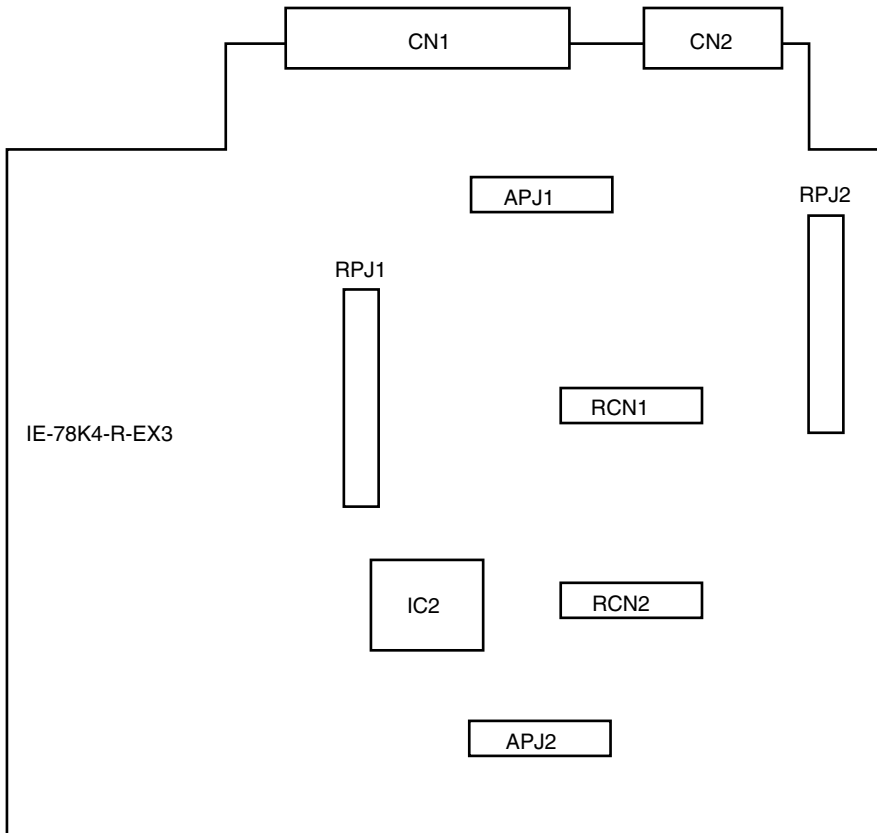

CHAPTER 3 INSTALLATION

This chapter describes methods for connecting the IE-78K4-R-EX3 to the in-circuit emulator (IE-784000-R), emulation board (IE-784000-R-EM), emulation probe, etc. Mode setting methods are also described.

Caution Connecting or removing components to or from the target system, or making switch or other setting changes must be carried out after the power supply to both the IE system and the target system has been switched OFF.

3.1 Installation Procedure

When using the IE-78K4-R-EX3, install the IE-78K4-R-EX3 according to the following procedure (1) to (7) (note that the installation procedure is different from the procedure in the **IE-784000-R User's Manual (U12903E)**).

Caution Connecting or removing components must be carried out after the power supply to both the IE-784000-R and the target system has been switched OFF.

Figure 3-1. Connection Outline of IE-78K4-R-EX3

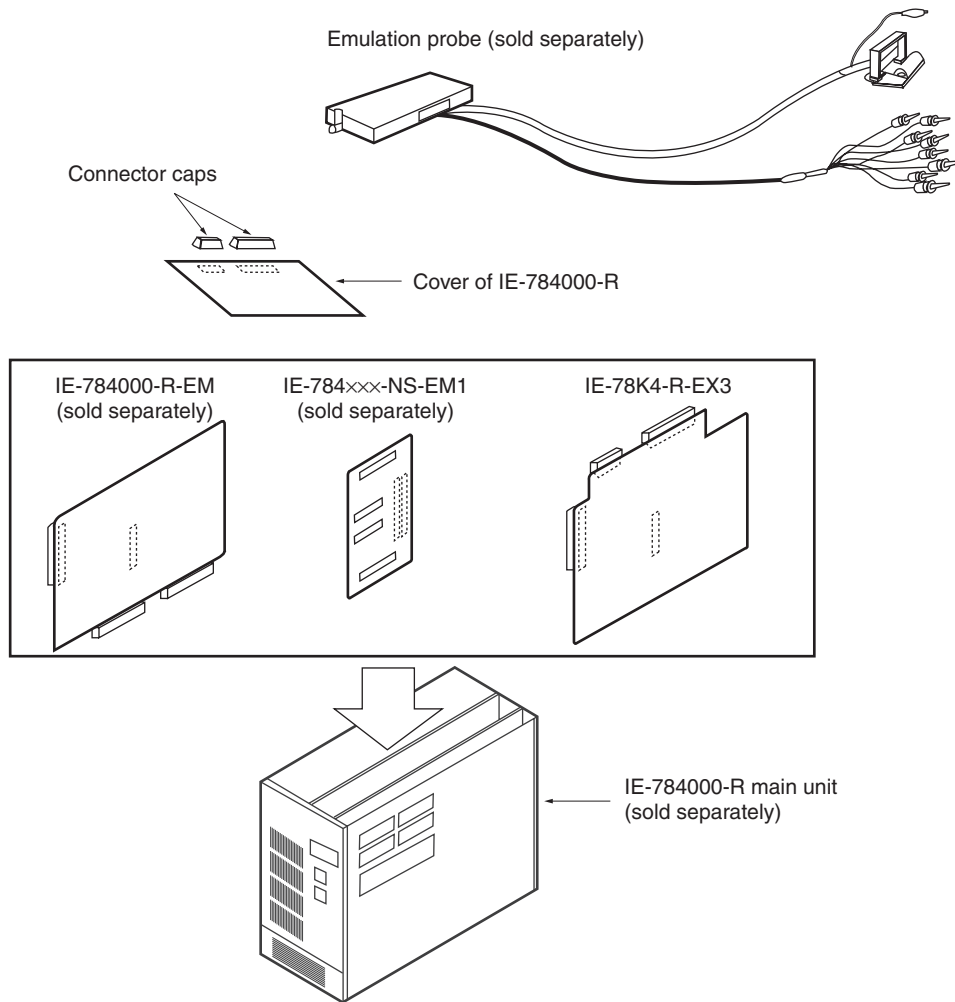

(1) Setting clock

Set the clock referring the user's manual of the IE-784xxx-NS-EM1 in use.

(2) Setting IE-784xxx-NS-EM1

Set the jumpers or switches in the IE-784xxx-NS-EM1, if necessary.

(3) Mounting IE-784xxx-NS-EM1 on IE-78K4-R-EX3

Connect the connectors RCN1 and RCN2 of the IE-78K4-R-EX3 and RCN1 and RCN2 of the IE-784xxx-NS-EM1, and the connectors APJ1 and APJ2 of the IE-78K4-R-EX3 and PJ1 and PJ2 of the IE-784xxx-NS-EM1.

Figure 3-2. Connecting IE-78K4-R-EX3 and IE-784xxx-NS-EM1

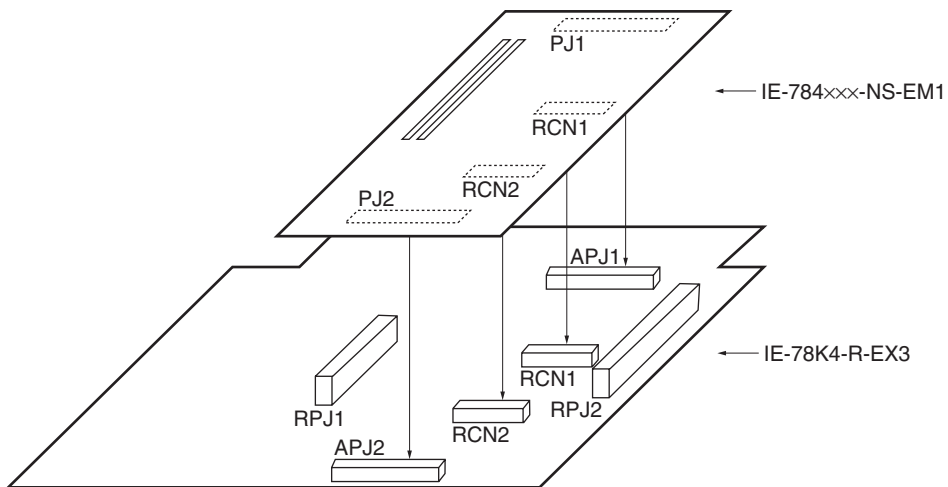

(4) Mounting IE-78K4-R-EX3 + IE-784xxx-NS-EM1 on IE-784000-R-EM

Connect the connectors PJ1 and PJ2 of the IE-784000-R-EM and the connectors RPJ1 and RPJ2 of the IE-78K4-R-EX3.

Figure 3-3. Connecting IE-784000-R-EM and IE-78K4-R-EX3 + IE-784xxx-NS-EM1

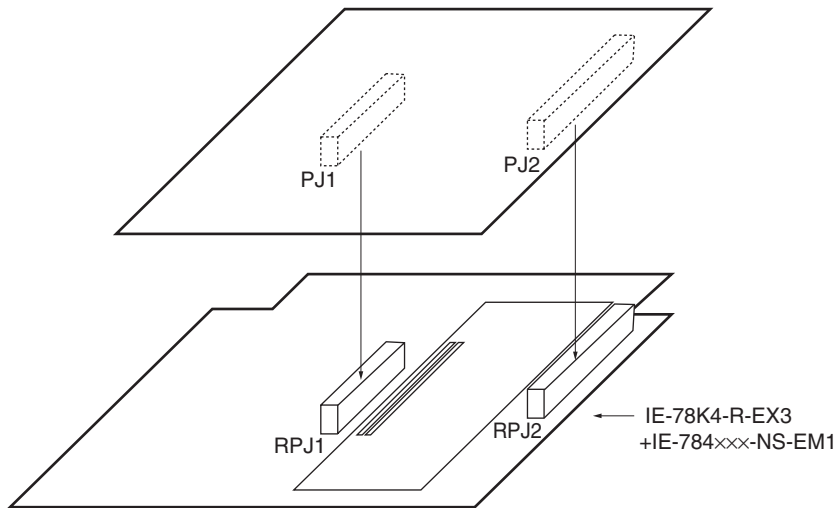

(5) Removing top cover

Remove the six screws on the top of the main unit as shown in Figure 3-4, and then remove the top cover.

Figure 3-4. Removing Top Cover

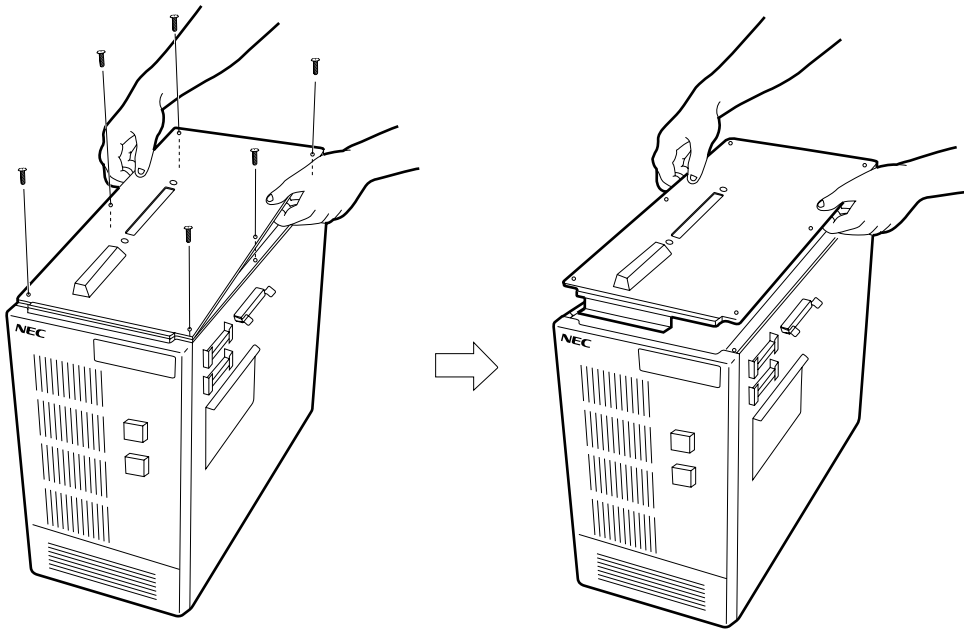

(6) Removing rubber cover on top cover

Remove the rubber cover on the top cover.

(7) Inserting in IE-784000-R

Insert the IE-784000-R-EM, IE-784xxx-NS-EM1, and IE-78K4-R-EX3 connected in (4) in the IE-784000-R (setting the IE-784000-R-EM to the first slot), replace the top cover, and return the screws to their original positions. (The IE-78K4-R-EX3 does not use a slot.)

Figure 3-5. Inserting in IE-784000-R

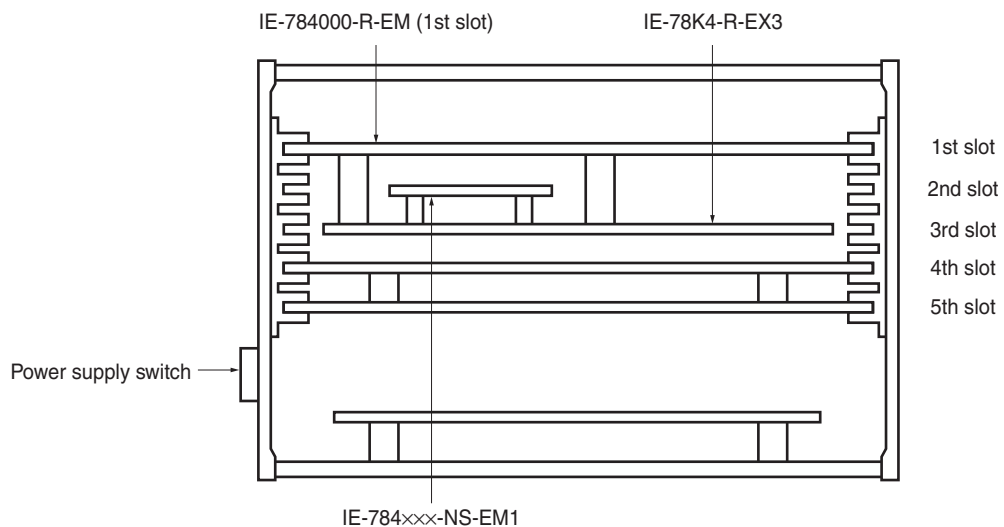

CHAPTER 4 CAUTIONS

When connecting with the IE-784225-NS-EM1, set the SW3-5 (NMI interrupt mask) of the IE-784225-NS-EM1 to OFF.

APPENDIX A EMULATION PROBE PIN ASSIGNMENT TABLE

Table A-1. Emulation Probe Pin Assignment Table (1/2)

(a) Assignment of CN1

CN1 Pin No.	Emulation Probe	CN1 Pin No.	Emulation Probe	CN1 Pin No.	Emulation Probe	CN1 Pin No.	Emulation Probe
1	GND	25	3	49	15	73	45
2	GND	26	2	50	14	74	46
3	30	27	1	51	100	75	47
4	29	28	NC	52	99	76	48
5	28	29	NC	53	98	77	49
6	27	30	NC	54	97	78	50
7	26	31	NC	55	96	79	63
8	25	32	NC	56	95	80	64
9	24	33	NC	57	94	81	65
10	23	34	NC	58	93	82	66
11	22	35	NC	59	92	83	67
12	21	36	40	60	91	84	81
13	20	37	39	61	NC	85	82
14	19	38	38	62	NC	86	83
15	13	39	37	63	NC	87	84
16	12	40	36	64	NC	88	85
17	11	41	35	65	NC	89	86
18	10	42	34	66	NC	90	87
19	9	43	33	67	NC	91	88
20	8	44	32	68	NC	92	89
21	7	45	31	69	41	93	90
22	6	46	18	70	42	94	NC
23	5	47	17	71	43	95	NC
24	4	48	16	72	44	96	NC

- Remarks**
1. The emulation probes are EP-78064GC-R, EP-78064GF-R, EP-784218GF-R, and EP-784915GF-R.
 2. The meanings of the symbols and numbers in the “Emulation Probe” column are as follows.
 - GND: Earth clip (GND)
 - EXT0 to EXT7: External sense clip No. 1 to No. 8
 - 1 to 100: Pin number of emulation probe tip
 - NC: No connection

Table A-1. Emulation Probe Pin Assignment Table (2/2)

(b) Assignment of CN2

CN2 Pin No.	Emulation Probe	CN2 Pin No.	Emulation Probe	CN2 Pin No.	Emulation Probe	CN2 Pin No.	Emulation Probe
1	NC	13	58	25	75	37	NC
2	NC	14	59	26	76	38	NC
3	NC	15	60	27	77	39	EXT0
4	NC	16	61	28	78	40	EXT1
5	NC	17	62	29	79	41	EXT2
6	51	18	68	30	80	42	EXT3
7	52	19	69	31	NC	43	EXT4
8	53	20	70	32	NC	44	EXT5
9	54	21	71	33	NC	45	EXT6
10	55	22	72	34	NC	46	EXT7
11	56	23	73	35	NC	47	GND
12	57	24	74	36	NC	48	GND

Remarks 1. The emulation probes are EP-78064GC-R, EP-78064GF-R, EP-784218GF-R, and EP-784915GF-R.

2. The meanings of the symbols and numbers in the “Emulation Probe” column are as follows.

- GND: Earth clip (GND)
- EXT0 to EXT7: External sense clip No. 1 to No. 8
- 51 to 80: Pin number of emulation probe tip
- NC: No connection

Facsimile Message

Although NEC has taken all possible steps to ensure that the documentation supplied to our customers is complete, bug free and up-to-date, we readily accept that errors may occur. Despite all the care and precautions we've taken, you may encounter problems in the documentation. Please complete this form whenever you'd like to report errors or suggest improvements to us.

From:

Name

Company

Tel.

FAX

Address

Thank you for your kind support.

North America

NEC Electronics Inc.
Corporate Communications Dept.
Fax: +1-800-729-9288
+1-408-588-6130

Hong Kong, Philippines, Oceania

NEC Electronics Hong Kong Ltd.
Fax: +852-2886-9022/9044

Taiwan

NEC Electronics Taiwan Ltd.
Fax: +886-2-2719-5951

Europe

NEC Electronics (Europe) GmbH
Market Communication Dept.
Fax: +49-211-6503-274

Korea

NEC Electronics Hong Kong Ltd.
Seoul Branch
Fax: +82-2-528-4411

Asian Nations except Philippines

NEC Electronics Singapore Pte. Ltd.
Fax: +65-250-3583

South America

NEC do Brasil S.A.
Fax: +55-11-6462-6829

P.R. China

NEC Electronics Shanghai, Ltd.
Fax: +86-21-6841-1137

Japan

NEC Semiconductor Technical Hotline
Fax: +81- 44-435-9608

I would like to report the following error/make the following suggestion:

Document title: _____

Document number: _____ Page number: _____

If possible, please fax the referenced page or drawing.

Document Rating	Excellent	Good	Acceptable	Poor
Clarity	<input type="checkbox"/>	<input type="checkbox"/>	<input type="checkbox"/>	<input type="checkbox"/>
Technical Accuracy	<input type="checkbox"/>	<input type="checkbox"/>	<input type="checkbox"/>	<input type="checkbox"/>
Organization	<input type="checkbox"/>	<input type="checkbox"/>	<input type="checkbox"/>	<input type="checkbox"/>